

EiceDRIVER™ SIL

High Voltage IGBT Driver for Automotive Applications

1EDI2004AS

Single Channel Isolated Driver for Inverter Systems

AA Step



RoHS



1 Overview

Quality Requirement Category: Automotive

The 1EDI2004AS is a high-voltage IGBT gate driver designed for automotive motor drives above 5 kW. The 1EDI2004AS is based on Infineon's Coreless Transformer (CLT) technology, providing galvanic insulation between low voltage and high voltage domains. The device has been designed to support 400 V, 600 V and 1200 V IGBT technologies.



The 1EDI2004AS can be connected on the low voltage side ("primary" side) to 5 V logic. A standard SPI interface allows the logic to configure and to control the advanced functions implemented in the driver.

On the high voltage side ("secondary" side), the 1EDI2004AS is dimensioned to drive an external booster stage or directly small IGBTs. Short propagation delays and controlled internal tolerances lead to minimal distortion of the PWM signal.

A large panel of safety-related functions has been implemented in the 1EDI2004AS, in order to support functional safety requirements at system level (as per ISO 26262). Besides, those integrated features ease the implementation of Active Short Circuit (ASC) strategies.

The 1EDI2004AS can be used optimally with Infineon's 1EBN100XAE "EiceDRIVER™ Boost" booster stage family.

Features

The following features are supported by the 1EDI2004AS:

- Single Channel IGBT Driver.
- On-chip galvanic insulation (up to 6kV).
- Support of 600 V and 1200 V IGBT technologies.
- Low propagation delay and minimal PWM distortion.
- Support of 5 V logic levels (primary side).
- 16-bit Standard SPI interface (up to 2 MBaud) with daisy chain support (primary side).
- Enable input pin (primary side).
- Pseudo-differential inputs for critical signals (primary side).
- Power-On Reset pin (primary side).
- Debug mode.

Overview

- Pulse Suppressor.
- Fully Programmable Active Clamping Inhibit signal (secondary side).
- Optimal support of EiceBoost functions.
- Operation with unipolar secondary supply possible ($V_{EE2}=V_{GND2}$).
- Fullfil BISS standard 2.0 (Class 3) for conducted emissions.
- 36-pin PG-DSO-36 green package.
- Automotive qualified (as per AEC Q100).

Safety Relevant Features

- Desaturation monitoring, with selectable blanking time in runtime.
- Overcurrent protection.
- Fully programmable Two-Level Turn-Off (static programming).
- Automatic Emergency Turn-Off in failure case.
- Externally triggered disabling of the output stage (tristate).
- Under- and over-voltage supervision of the secondary power supplies.
- OVLO2 failure reaction can be modified in runtime.
- NFLTA and NFLTB notification pins for fast system response time (primary side).
- Safe internal state machine.
- Weak Turn-On functionality.
- Internal clock monitoring.
- Gate signal monitoring comparators.
- Individual error and status flags readable via SPI.
- Support for Active Short Circuit strategies.
- Full diagnostic capability.
- In-application testability of safety critical functions.
- Suitable for systems up to ASIL D requirements (as per ISO 26262).
- Compliant to ISO 26262 standard - ASIL A.

Target Applications

- Inverters for automotive Hybrid Electric Vehicles (HEV) and Electric Vehicles (EV).
- High Voltage DC/DC converter.
- Industrial Drive.

Type	Package	Marking
1EDI2004AS	PG-DSO-36-63	1EDI2004AS

Revision History

Page or Item	Subjects (major changes since previous revision)
Rev 1.8, 2018-12-19	
All,	Initial data sheet.

Trademarks of Infineon Technologies AG

AURIX™, C166™, CanPAK™, CIPOS™, CIPURSE™, EconoPACK™, CoolMOS™, CoolSET™, CORECONTROL™, CROSSAVE™, DAVE™, EasyPIM™, EconoBRIDGE™, EconoDUAL™, EconoPIM™, EiceDRIVER™, eupec™, FCOS™, HITFET™, HybridPACK™, I²RF™, ISOFACE™, IsoPACK™, MIPAQ™, ModSTACK™, my-d™, NovalithIC™, OptiMOS™, ORIGA™, PRIMARION™, PrimePACK™, PrimeSTACK™, PRO-SIL™, PROFET™, RASIC™, ReverSave™, SatRIC™, SIEGET™, SINDRION™, SIPMOS™, SmartLEWIS™, SOLID FLASH™, TEMPFET™, thinQ!™, TRENCHSTOP™, TriCore™.

Other Trademarks

Advance Design System™ (ADS) of Agilent Technologies, AMBA™, ARM™, MULTI-ICE™, KEIL™, PRIMECELL™, REALVIEW™, THUMB™, μVision™ of ARM Limited, UK. AUTOSAR™ is licensed by AUTOSAR development partnership. Bluetooth™ of Bluetooth SIG Inc. CAT-ig™ of DECT Forum. COLOSSUS™, FirstGPS™ of Trimble Navigation Ltd. EMV™ of EMVCo, LLC (Visa Holdings Inc.). EPCOS™ of Epcos AG. FLEXGO™ of Microsoft Corporation. FlexRay™ is licensed by FlexRay Consortium. HYPERTERMINAL™ of Hilgraeve Incorporated. IEC™ of Commission Electrotechnique Internationale. IrDA™ of Infrared Data Association Corporation. ISO™ of INTERNATIONAL ORGANIZATION FOR STANDARDIZATION. MATLAB™ of MathWorks, Inc. MAXIM™ of Maxim Integrated Products, Inc. MICROTEC™, NUCLEUS™ of Mentor Graphics Corporation. Mifare™ of NXP. MIPI™ of MIPI Alliance, Inc. MIPS™ of MIPS Technologies, Inc., USA. muRata™ of MURATA MANUFACTURING CO., MICROWAVE OFFICE™ (MWO) of Applied Wave Research Inc., OmniVision™ of OmniVision Technologies, Inc. Openwave™ Openwave Systems Inc. RED HAT™ Red Hat, Inc. RFMD™ RF Micro Devices, Inc. SIRIUS™ of Sirius Satellite Radio Inc. SOLARIS™ of Sun Microsystems, Inc. SPANSION™ of Spansion LLC Ltd. Symbian™ of Symbian Software Limited. TAIYO YUDEN™ of Taiyo Yuden Co. TEAKLITE™ of CEVA, Inc. TEKTRONIX™ of Tektronix Inc. TOKO™ of TOKO KABUSHIKI KAISHA TA. UNIX™ of X/Open Company Limited. VERILOG™, PALLADIUM™ of Cadence Design Systems, Inc. VLYNQ™ of Texas Instruments Incorporated. VXWORKS™, WIND RIVER™ of WIND RIVER SYSTEMS, INC. ZETEX™ of Diodes Zetex Limited.

Last Trademarks Update 2011-02-24

Table of Contents

1	Overview	1
	Table of Contents	4
	List of Figures	7
	List of Tables	8
2	Functional Description	10
2.1	Introduction	10
2.2	Pin Configuration and Functionality	11
2.2.1	Pin Configuration	11
2.2.2	Pin Functionality	13
2.2.2.1	Primary Side	13
2.2.2.2	Secondary Side	14
2.2.2.3	Pull Devices	15
2.3	Block Diagram	17
2.4	Functional Block Description	18
2.4.1	Power Supplies	18
2.4.2	Clock Domains	18
2.4.3	PWM Input Stage	19
2.4.4	SPI Interface	21
2.4.4.1	Overview	21
2.4.4.2	General Operation	22
2.4.4.3	Definitions	24
2.4.4.4	SPI Data Integrity Support	26
2.4.4.4.1	Parity Bit	26
2.4.4.4.2	SPI Error	26
2.4.4.5	Protocol Description	27
2.4.4.5.1	Command Catalog	27
2.4.4.5.2	Word Convention	27
2.4.4.5.3	ENTER_CMODE Command	28
2.4.4.5.4	ENTER_VMODE Command	28
2.4.4.5.5	EXIT_CMODE Command	28
2.4.4.5.6	NOP Command	29
2.4.4.5.7	READ Command	29
2.4.4.5.8	WRITEH	29
2.4.4.5.9	WRITEL	30
2.4.5	Operating Modes	31
2.4.5.1	General Operation	31
2.4.5.2	Definitions	32
2.4.5.2.1	Events and State Transitions	32
2.4.5.2.2	Emergency Turn-Off Sequence	33
2.4.5.2.3	Ready, Disabled, Enabled and Active State	33
2.4.5.3	Operation Modes Description	34
2.4.5.4	Activating the device after reset	36
2.4.5.5	Activating the device after an Event Class A or B	36
2.4.5.6	Debug Mode	36
2.4.6	Driver Functionality	37
2.4.6.1	Overview	37
2.4.6.2	Switching Sequence Description	41

2.4.6.3	Active Miller Clamping Transistor Clamping	43
2.4.6.4	Disabling the output stage	44
2.4.6.5	Passive Clamping	44
2.4.7	Fault Notifications	45
2.4.8	EN Signal Pin	46
2.4.9	Internal Supervision	47
2.4.9.1	Lifesign watchdog	47
2.4.9.2	Oscillator Monitoring	47
2.4.9.3	Memory Supervision	48
2.4.9.4	Hardware Failure Behavior	48
2.4.10	Reset Events	49
2.4.11	Operation in Configuration Mode	51
2.4.11.1	Static Configuration Parameters	51
2.4.11.1.1	Configuration of the SPI Parity Check	51
2.4.11.1.2	Configuration of the V_{BE} Compensation	51
2.4.11.1.3	Clamping of DESAT pin	52
2.4.11.1.4	Activation of the Pulse Suppressor	52
2.4.11.1.5	Configuration of the Verification Mode Time Out Duration	52
2.4.11.1.6	Configuration of the TTOFF Delays	52
2.4.11.1.7	Configuration of the TTOFF Plateau Level	52
2.4.11.1.8	Configuration of the DESAT Blanking Time	52
2.4.11.1.9	Configuration of the OCP Blanking Time	53
2.4.11.1.10	Configuration of DACLP Activation Time	53
2.4.11.2	Delay Calibration	53
3	Protection and Diagnostics	54
3.1	Supervision Overview	54
3.2	Protection Functions: Category A	56
3.2.1	Desaturation Protection	56
3.2.2	Overcurrent Protection	58
3.2.3	External Enable	60
3.3	Protection Functions: Category B	61
3.3.1	Power Supply Voltage Monitoring	61
3.4	Protection Functions: Category C	63
3.4.1	Shoot Through Protection function	63
3.4.2	Gate Monitoring	64
3.4.3	SPI Error Detection	64
3.4.4	Active Short Circuit Support	65
3.5	Protection Functions: Category D	66
3.5.1	Operation in Verification Mode and Weak Active Mode	66
3.5.2	Weak Turn On	66
3.5.3	DESAT Supervision Level 1	68
3.5.4	DESAT Supervision Level 2	68
3.5.5	DESAT Supervision Level 3	69
3.5.6	OCP Supervision Level 1	69
3.5.7	OCP Supervision Level 3	70
3.5.8	Power Supply Monitoring Supervision	70
3.5.9	Internal Clock Supervision	72
4	Register Description	73
4.1	Primary Register Description	75
4.2	Secondary Registers Description	93

4.3	Read / Write Address Ranges	116
5	Specification	118
5.1	Typical Application Circuit	118
5.2	Absolute Maximum Ratings	121
5.3	Operating range	122
5.4	Thermal Characteristics	122
5.5	Electrical Characteristics	123
5.5.1	Power Supply	123
5.5.2	Internal Oscillators	124
5.5.3	Primary I/O Electrical Characteristics	125
5.5.4	Secondary I/O Electrical Characteristics	127
5.5.5	Switching Characteristics	130
5.5.6	Desaturation Protection	132
5.5.7	Overcurrent Protection	132
5.5.8	Error Detection Timing	133
5.5.9	SPI Interface	134
5.5.10	Insulation Characteristics	135
6	Package Information	136

List of Figures

Figure 1	Pin Configuration	11
Figure 2	Block Diagram	17
Figure 3	PWM Input Stage	19
Figure 4	STP: Inhibition Time Definition	20
Figure 5	STP: Example of Operation	20
Figure 6	SPI Regular Bus Topology	22
Figure 7	SPI Daisy Chain Bus Topology.	23
Figure 8	Response Answer Principle - Daisy Chain Topology	25
Figure 9	Response Answer Principle - Regular Topology	25
Figure 10	SPI Commands Overview.	27
Figure 11	Operating Modes State Diagram	31
Figure 12	Output Stage Diagram of Principle	37
Figure 13	TTOFF: Principle of Operation	39
Figure 14	TTOFF: pulse suppressor aborting a turn-on sequence.	40
Figure 15	Idealized Switching Sequence (Regular Turn-Off)	42
Figure 16	AMCLP operation	43
Figure 17	DESAT Function: Diagram of Principle.	56
Figure 18	DESAT Operation	57
Figure 19	DESAT Operation with DESAT clamping enabled	58
Figure 20	OCP Function: Principle of Operation.	59
Figure 21	Power Supply Supervision Function	61
Figure 22	Shoot Through Protection: Principle of Operation	63
Figure 23	ASC Strategy Support	65
Figure 24	Idealized Weak Turn-On Sequence	67
Figure 25	Typical Application Example.	120
Figure 26	SPI Interface Timing	134
Figure 27	Package Dimensions	136
Figure 28	Recommended Footprint	136
Figure 29	Packing Information (Tape & Reel).	137

List of Tables

Table 1	Pin Configuration	11
Table 2	Internal pull devices	15
Table 3	SPI Command Catalog	27
Table 4	Word Convention	28
Table 5	ENTER_CMODE request and answer messages	28
Table 6	ENTER_VMODE request and answer messages	28
Table 7	EXIT_CMODE request and answer messages	29
Table 8	NOP request and answer messages	29
Table 9	READ request and answer messages	29
Table 10	WRITEH request and answer messages	30
Table 11	WRITEL request and answer messages	30
Table 12	Failure Notification Clearing	45
Table 13	System Supervision Overview	47
Table 14	Failure Events Summary	48
Table 15	Reset Events Summary	50
Table 16	Pin behavior (primary side) in case of reset condition	50
Table 17	Pin behavior (secondary side) in case of reset condition	51
Table 18	Safety Related Functions	54
Table 19	DESAT Protection Overview	56
Table 20	OCP Function Overview	58
Table 21	External Enable Function Overview	60
Table 22	Power Supply Voltage Monitoring Overview	61
Table 23	STP Overview	63
Table 24	Gate Monitoring Overview	64
Table 25	SPI Error Detection Overview	64
Table 26	Active Short Circuit Support Overview	65
Table 27	DESAT Supervision Level 1 Overview	68
Table 28	DESAT Supervision Level 2 Overview	68
Table 29	DESAT Supervision Level 3 Overview	69
Table 30	OCP Supervision Level 1 Overview	69
Table 31	OCP Supervision Level 3 Overview	70
Table 32	Power Supply Monitoring Supervision Overview	70
Table 33	Primary Clock Supervision Overview	72
Table 34	Register Address Space	73
Table 35	Register Overview	73
Table 36	Bit Access Terminology	74
Table 37	Read Access Validity	116
Table 38	Write Access Validity	117
Table 39	Component Values	118
Table 40	Absolute Maximum Ratings	121
Table 41	Operating Conditions	122
Table 42	Thermal Characteristics	122
Table 43	Power Supplies Characteristics	123
Table 44	Internal Oscillators	124
Table 45	Electrical Characteristics for Pins: INP, INSTP, EN	125
Table 46	Electrical Characteristics for Pins: SCLK, SDI, NCS	125
Table 47	Electrical Characteristics for Pins: NRST/RDY	126
Table 48	Electrical Characteristics for Pins: SDO	126
Table 49	Electrical Characteristics for Pins: NFLTA, NFLTB	126

List of Tables

Table 50	Electrical Characteristics for Pins: TON , TOFF & GATE	127
Table 51	Electrical Characteristics for Pins: OSD , DEBUG	127
Table 52	Electrical Characteristics for Pin: NUV2	127
Table 53	Electrical Characteristics for Pins: DACLP	128
Table 54	Electrical Characteristics for Pins: AMCLP	128
Table 55	Electrical Characteristics for Pin: VREG	129
Table 56	Switching Characteristics	130
Table 57	DESAT characteristics	132
Table 58	OCP characteristics	132
Table 59	Error Detection Timing	133
Table 60	SPI Interface Characteristics	134
Table 61	Isolation Characteristics referring to DIN EN 60747-5-2 (VDE 0884 - 10):2006-12	135
Table 62	Isolation Characteristics referring to UL 1577	135

2 Functional Description

2.1 Introduction

The 1EDI2004AS is an advanced single channel IGBT driver that can also be used for driving power MOS devices. The device has been developed in order to optimize the design of high performance safety relevant automotive systems.

The device is based on Infineon's Coreless Transformer Technology and consist of two chips separated by a galvanic isolation. The low voltage (primary) side can be connected to a standard 5 V logic. The high voltage (secondary) side is in the DC-link voltage domain.

Internally, the data transfers are ensured by two independent communication channels. One channel is dedicated to transferring the ON and OFF information of the PWM input signal only. This channel is unidirectional (from primary to secondary). Because this channel is dedicated to the PWM information, latency time and PWM distortion are minimized. The second channel is bidirectional and is used for all the other data transfers (e.g. status information, etc).

The 1EDI2004AS supports advanced functions in order to optimize the switching behavior of the IGBT. Furthermore, it supports several monitoring and protection functions, making it suitable for systems having to fulfill ASIL requirements (as per ISO 26262).

Functional Description

2.2 Pin Configuration and Functionality

2.2.1 Pin Configuration

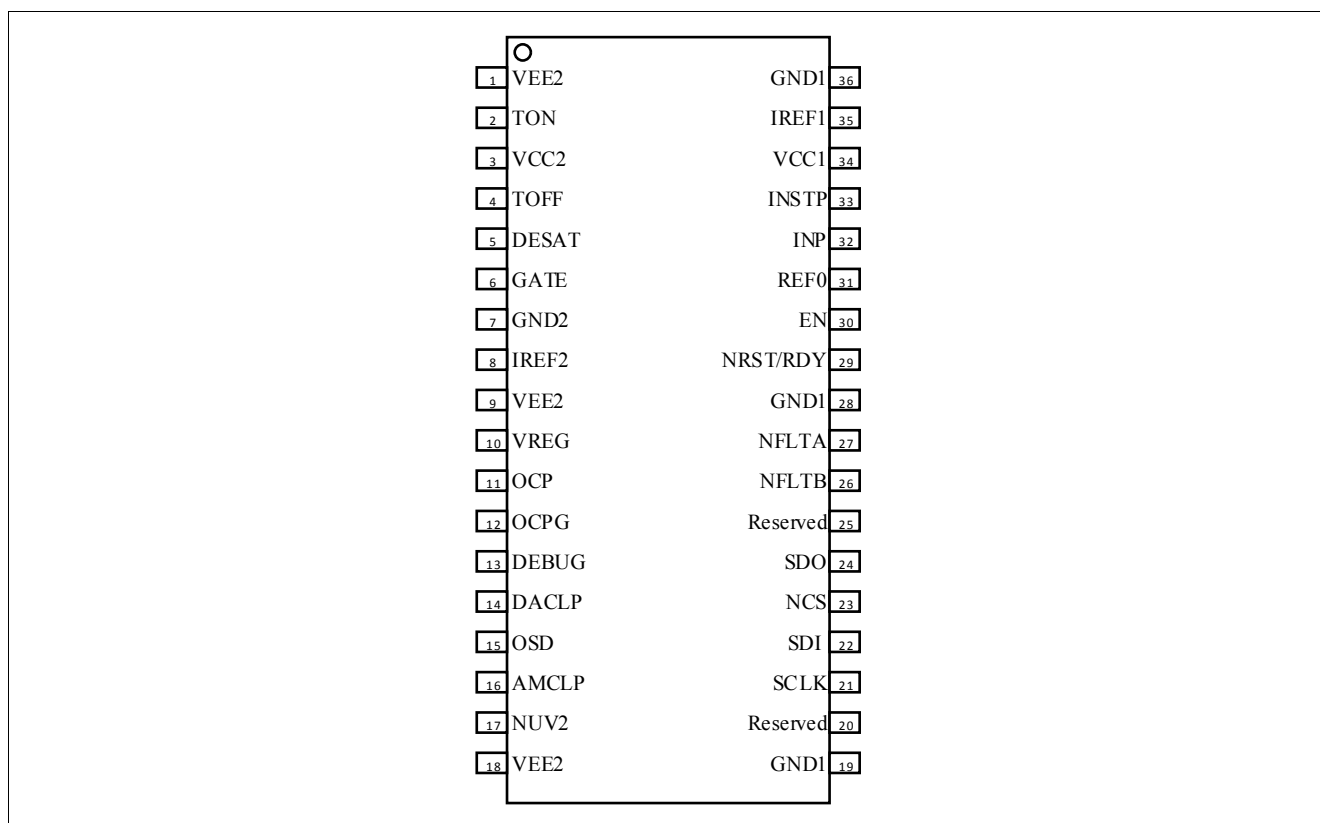

Figure 1 Pin Configuration

Table 1 Pin Configuration

Pin Number	Symbol	I/O	Voltage Class	Function
1,9,18	VEE2	Supply	Supply	Negative Power Supply ¹⁾ .
2	TON	Output	15V Secondary	Turn-On Output. ²⁾
3	VCC2	Supply	Supply	Positive Power Supply.
4	TOFF	Output	15V Secondary	Turn-Off Output. ²⁾
5	DESAT	Input	15V Secondary	Desaturation Protection Input.
6	GATE	Input	15V Secondary	Gate Monitoring Input.
7	GND2	Ground	Ground	Ground.
8	IREF2	Input	5V Secondary	External Reference Input.
10	VREG	Output	5V Secondary	Reference Output Voltage. ²⁾
11	OCP	Input	5V Secondary	Over Current Protection.
12	OCPG	Ground	Ground	Ground for the OCP function,
13	DEBUG	Input	5V Secondary	Debug Input.

Functional Description

Table 1 Pin Configuration (cont'd)

Pin Number	Symbol	I/O	Voltage Class	Function
14	DACLP	Output	5V Secondary	Active Clamping Disable Output.(push-pull) ²⁾
15	OSD	Input	5V Secondary	Output Stage Disable Input.
16	AMCLP	Output	5V Secondary	Active Miller Clamping control output. (push-pull) ²⁾
17	NUV2	Output	5V Secondary	V _{CC2} not valid notification output. (open drain) ²⁾
19, 28, 36	GND1	Ground	Ground	Ground ³⁾ .
20	Reserved	Reserved	Reserved	Reserved. This pin shall be connected to GND1 .
21	SCLK	Input	5V Primary	SPI Serial Clock Input.
22	SDI	Input	5V Primary	SPI Serial Data Input.
23	NCS	Input	5V Primary	SPI Chip Select Input (low active).
24	SDO	Output	5V Primary	SPI Serial Data Output. (push-pull) ²⁾
25	Reserved	Reserved	Reserved	Reserved. This pin shall be connected to GND1 .
26	NFLT B	Output	5V Primary	Fault B Output (low active, open drain). ²⁾
27	NFLT A	Output	5V Primary	Fault A Output (low active, open drain). ²⁾
29	NRST/RDY	Input/Output	5V Primary	Reset Input (low active, open drain). This signal notifies that the device is “ready”. ²⁾
30	EN	Input	5V Primary	Enable Input.
31	REF0	Ref. Ground	Ground	Reference Ground for signals INP , INSTP , EN .
32	INP	Input	5V Primary	Positive PWM Input.
33	INSTP	Input	5V Primary	Monitoring PWM Input.
34	VCC1	Supply Input	Supply	Positive Power Supply.
35	IREF1	Input	5V Primary	External Reference Input.

- 1) All **VEE2** pins must be connected together.
- 2) Pin is not protected against short circuit to respective supply or ground potential.
- 3) All **GND1** pins must be connected together.

Functional Description

2.2.2 Pin Functionality

2.2.2.1 Primary Side

GND1

Ground connection for the primary side.

VCC1

5V power supply for the primary side (referring to GND1).

INP

Non-inverting PWM input of the driver. The internal structure of the pad makes the IC robust against glitches. An internal weak pull-down resistor to V_{REF0} drives this input to Low state in case the pin is floating.

INSTP

Monitoring PWM input for shoot through protection. The internal structure of the pad makes the IC robust against glitches. An internal weak pull-down resistor to V_{REF0} drives this input to Low state in case the pin is floating.

REF0

Reference Ground signal for the signals **INP**, **INSTP**, **EN**. This pin should be connected to the ground signal of the logic issuing those signals.

EN

Enable Input Signal. This signal allows the logic on the primary side to turn-off and deactivate the device. An internal weak pull-down resistor to V_{REF0} drives this input to Low state in case the pin is floating. This pin reacts on logic levels.

NFLTA

Open-Drain Output signal used to report major failure events (Event Class A). In case of an error event, **NFLTA** is driven to Low state. This pin shall be connected externally to V_{CC1} with a pull-up resistance.

NFLTB

Open-Drain Output signal used to report major failure events (Event Class B) and reset events. In case of an error event, **NFLTB** is driven to Low state. This pin shall be connected externally to V_{CC1} with a pull-up resistance.

SCLK

Serial Clock Input for the SPI interface. An internal weak pull-up device to V_{CC1} drives this input to high state in case the pin is floating.

SDO

Serial Data Output (push-pull) for the SPI interface.

Functional Description

SDI

Serial Data Input for the SPI interface. An internal weak pull-up device to V_{CC1} drives this input to high state in case the pin is floating.

NCS

Chip Select input for the SPI interface. This signal is low active. An internal weak pull-up device to V_{CC1} drives this input to High state in case the pin is floating.

IREF1

Reference input of the primary chip. This pin shall be connected to V_{GND1} via an external resistor.

NRST/RDY

Open drain reset input. This signal is low-active. When a valid signal is received on this pin, the device is brought in its default state. This signal is also used as a “ready notification”. A high level on this pin indicates that the primary chip is functional.

2.2.2.2 Secondary Side

VEE2

Negative power supply for the secondary side, referring to V_{GND2} .

VCC2

Positive power supply for the secondary side, referring to V_{GND2} .

GND2

Reference ground for the secondary side.

DESAT

Desaturation Protection input pin. The function associated with this pin monitors the V_{CE} voltage of the IGBT. An internal pull-up resistor to V_{CC2} drives this signal to High level in case it is floating.

OCP

Over Current Protection input pin. The function associated with this pin monitors the voltage across a sensing resistance located on the auxiliary path of a Current Sense IGBT. An internal weak pull-up resistor to the internal 5V reference drives this input to High state in case the pin is floating.

OCPG

Over Current Protection Ground.

TON

Output pin for turning on the IGBT.

TOFF

Output pin for turning off the IGBT.

Functional Description

GATE

Input pin used to monitor the IGBT gate voltage.

OSD

Output Stage Disable input. A High Level on this pin tristates the output stage. An internal weak pull-down resistor to V_{GND2} drives this input to Low state in case the pin is floating.

DACLP

Output pin used to disable the active clamping function of the booster.

DEBUG

Debug input pin. This pin is latched at power-up. When a High level is detected on this pin, the device enters a special mode where it can be operated without SPI interface. This feature is for development purpose only. This pin should normally be tied to V_{GND2} . An internal weak pull-down resistor to V_{GND2} drives this input to Low state in case the pin is floating.

IREF2

Reference input of the secondary chip. This pin shall be connected to V_{GND2} via an external resistor.

VREG

Reference Output voltage. This pin shall be connected to an external capacitance to V_{GND2} .

NUV2

V_{CC2} not valid notification signal (Open Drain). This signal drives a low level when V_{CC2} is below V_{UVLO2L} or when the internal 5V digital supply is not valid. When both supplies are valid, this pin is in high impedance state. This pin shall be connected externally to a 5V reference with a pull-up resistance to ensure level read-out over the respective register. The pin can be connected also to respective ground potential (This enables usage together with OSD pin).

AMCLP

Active Miller Clamping External Enable Output. The signal goes to High level when V_{GATE} is lower than V_{GATE1} during turn-off.

2.2.2.3 Pull Devices

Some of the pins are connected internally to pull-up or pull-down devices. This is summarized in [Table 2](#).

Table 2 Internal pull devices

Signal	Device
INP	Weak pull down to V_{REF0}
INSTP	Weak pull down to V_{REF0}
EN	Weak pull down to V_{REF0}
SCLK	Weak pull up to V_{CC1}
SDI	Weak pull up to V_{CC1}
NCS	Weak pull up to V_{CC1}

Functional Description

Table 2 Internal pull devices

Signal	Device
DESAT	Weak pull up to V_{CC2}
OSD	Weak pull down to V_{GND2}
OCP	Weak pull up to 5V internal reference
DEBUG	Weak pull down to V_{GND2}

Functional Description

2.3 Block Diagram

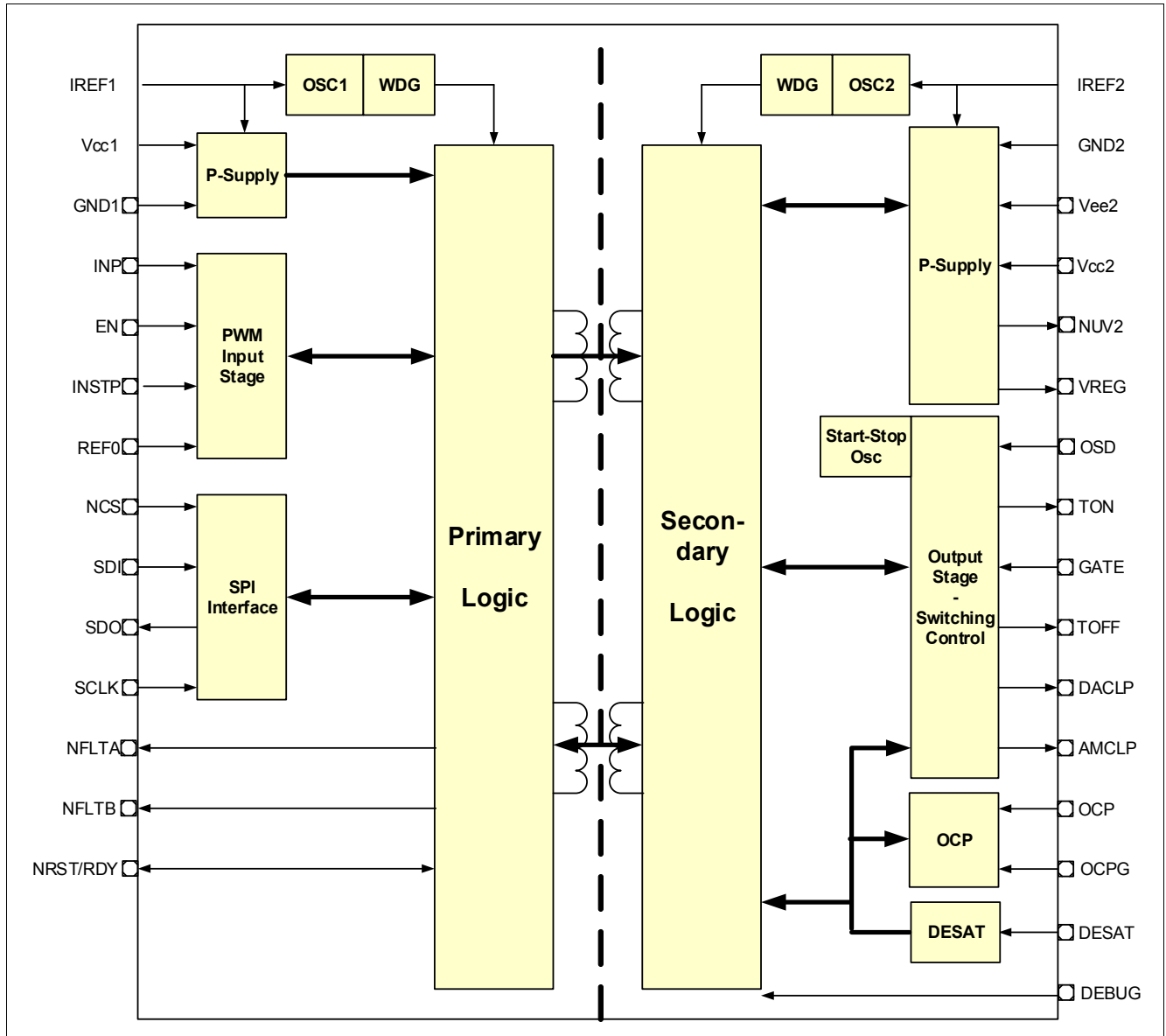

Figure 2 Block Diagram

2.4 Functional Block Description

2.4.1 Power Supplies

On the primary side, the 1EDI2004AS needs a single 5V supply source V_{CC1} for proper operation. This makes the device compatible to most of the microcontrollers available for automotive applications.

On the secondary side, the 1EDI2004AS needs two power supplies for proper operation.

- The positive power supply V_{CC2} is typically set to 16.5 V (referring to V_{GND2}).
- The negative supply V_{EE2} is typically set to -4 V or 0V (referring to V_{GND2}).

Under- and over-voltage monitoring is performed continuously during operation of the device (see [Chapter 3.3.1](#)).

A 5V supply for the digital domain on the secondary side is generated internally (present at pin [VREG](#)).

2.4.2 Clock Domains

The clock system of the 1EDI2004AS is based on three oscillators defining each a clock domain:

- One RC oscillator (OSC1) for the primary chip.
- One RC oscillator (OSC2) for the secondary chip excepting the output stage.
- One Start-Stop oscillator (SSOSC2) for the output stage on the secondary side.

The two RC oscillators are running constantly. They are also monitored constantly, and large deviations from the nominal frequency are identified as a system failure (Event Class B, see [Chapter 3.3](#)).

The Start Stop oscillator is controlled by the PWM command.

Functional Description

2.4.3 PWM Input Stage

The PWM input stage generates from the external signals **INP**, **INSTP** and **EN** the turn-on and turn-off commands to the secondary side. The general structure of the PWM input block is shown **Figure 3**.

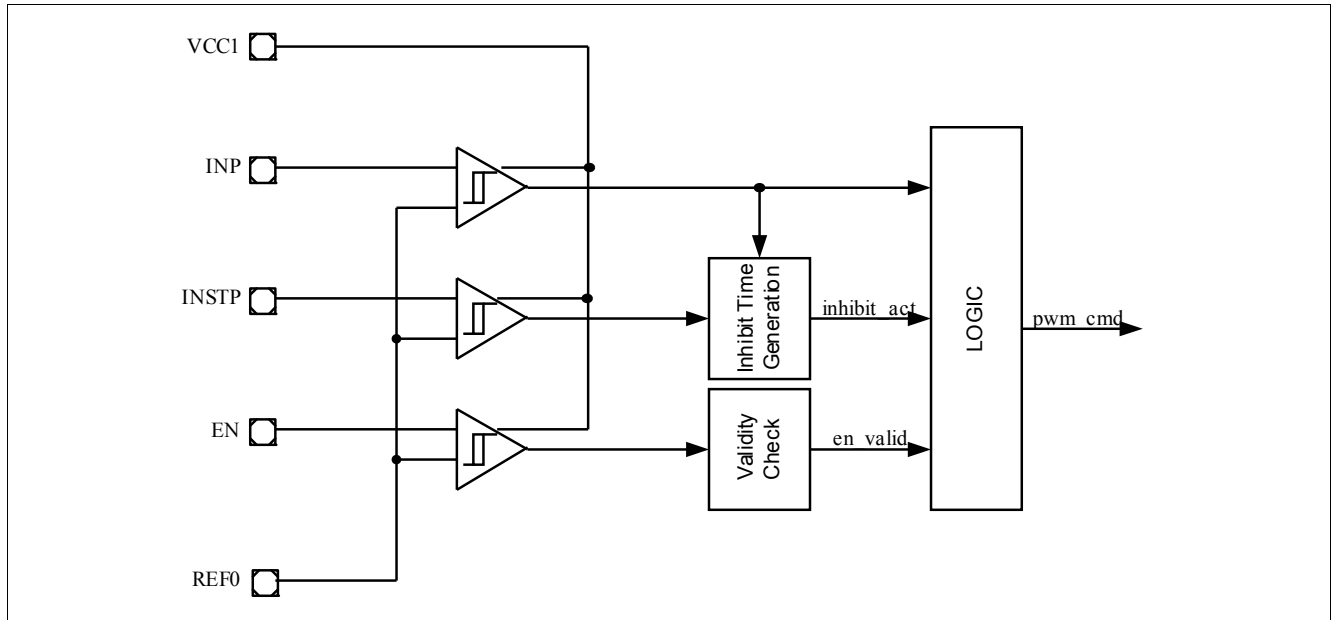

Figure 3 PWM Input Stage

Signals **INP**, **INSTP** and **EN** are pseudo-differential, in the sense that they are not referenced to the common ground **GND1** but to signal **REF0**. This is intended to make the device more robust against ground bouncing effects.

Note:

1. Glitches shorter than t_{INPS1} (see [Table 45](#)) occurring at signal **INP** are filtered internally.
2. Pulses at **INP** below t_{INPPD} (see [Table 45](#)) might be distorted or suppressed.

The 1EDI2004AS supports non-inverted PWM signals only. When a High level on pin **INP** is detected while signals **INSTP** and **EN** are valid, a turn-on command is issued to the secondary chip. A Low level at pin **INP** issues a turn-off command to the secondary chip.

Signal **EN** can inhibit turn-on commands received at pin **INP**. A valid signal **EN** is required in order to have turn-on commands issued to the secondary chip. If an invalid signal is provided, the PWM input stage issues constantly turn-off commands to the secondary chip. The functionality of signal **EN** is detailed in [Chapter 2.4.8](#).

Note: After an invalid-to valid-transition of signal **EN**, a minimum delay of t_{INPEN} should be inserted before turning **INP** on.

As shown in [Figure 4](#), signal **INSTP** provides a Shoot-Through Protection (STP) to the system. When signal at pin **INSTP** is at High level, the internal signal `inhibit_act` is activated. The inhibition time is defined as the pulse duration of signal `inhibit_act`. It corresponds to the pulse duration of signal **INSTP** to which a minimum dead time is added. During the inhibition time, rising edges of signal **INP** are inhibited. Bit **PSTAT2.STP** is set for the duration of the inhibition time.

Functional Description

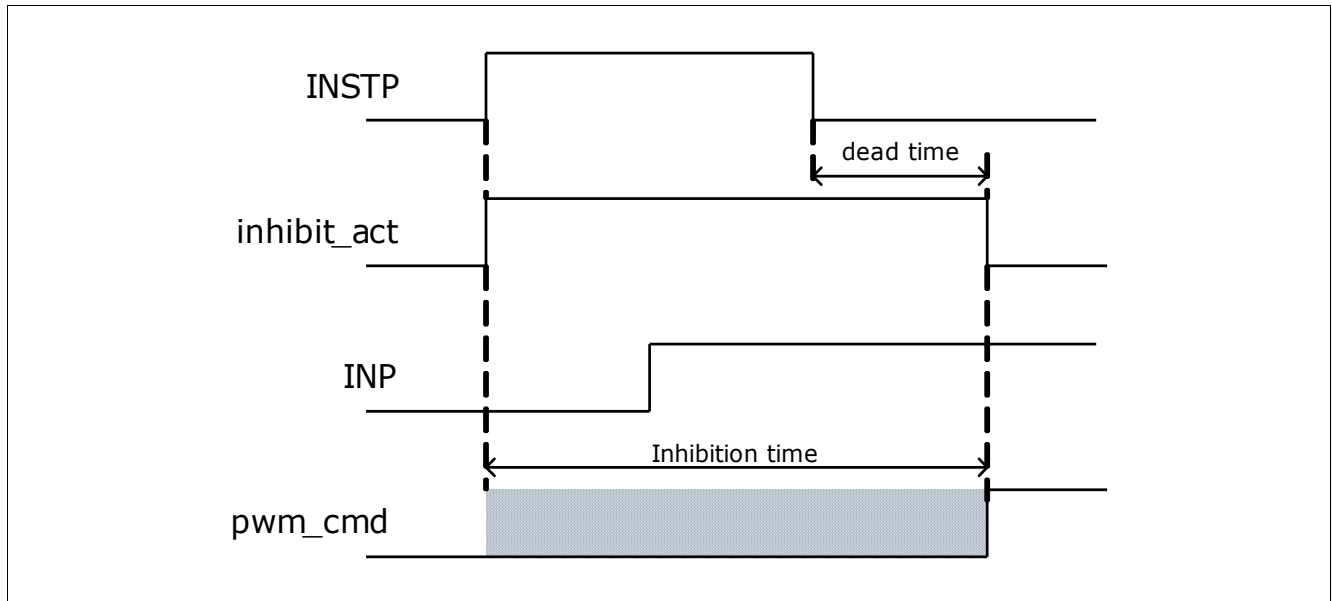

Figure 4 STP: Inhibition Time Definition

It shall be noted that during the inhibition time, signal `pwm_cmd` is not forced to Low. It means that if the device is already turned-on when `INSTP` is High, it stays turned-on until the signal at pin `INP` goes Low. This is depicted in [Figure 5](#).

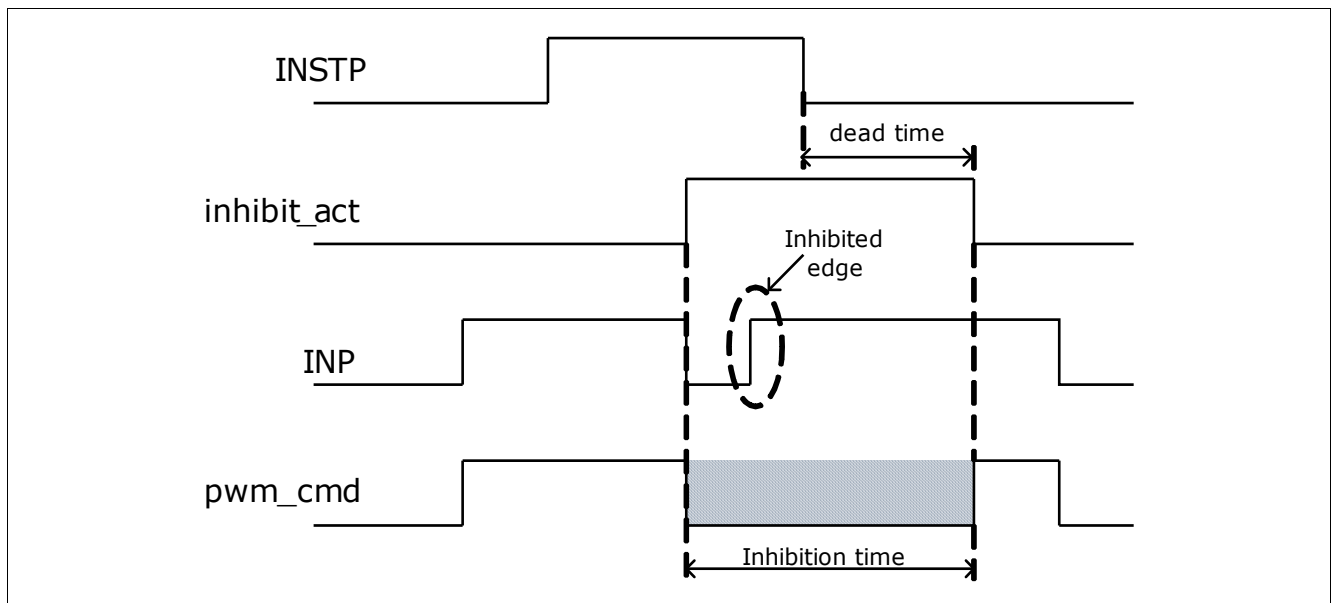

Figure 5 STP: Example of Operation

When a condition occurs where a rising edge of signal `INP` is inhibited, an error notification is issued. See [Chapter 3.4.1](#) for more details.

Note: If a rising edge shortly after reset occurs at `INP` may `PER.STPER` gets set, anyway an immediatly turn-on of the secondary is prevented.

Functional Description

2.4.4 SPI Interface

This chapter describes the functionality of the SPI block.

2.4.4.1 Overview

The standard SPI interface implemented on the 1EDI2004AS is compatible with most of the microcontrollers available for automotive and industrial applications. The following features are supported by the SPI interface:

- Full-duplex bidirectional communication link.
- SPI Slave mode (only).
- 16-bit frame format.
- Daisy chain capability.
- MSB first.
- Parity Check (optional) and Parity Bit generation (LSB).

The SPI interface of the 1EDI2004AS provides a standardized bidirectional communication interface to the main microcontroller. From the architectural point of view, it fulfills the following functions:

- Initialization of the device.
- Configuration of the device (static and runtime).
- Reading of the status of the device (static and runtime).
- Operation of the verification modes of the device.

The purpose of the SPI interface is to exchange data which have relaxed timing constraints compared to the PWM signals (from the point of view of the motor control algorithm). The IGBT switching behavior is for example controlled directly by the PWM input. Similarly, critical application failures requiring fast reaction are notified on the primary side via the feedback signals **NFLTA**, **NFLT B** and **NRST/RDY**.

In order to minimize the complexity of the end-application and to optimize the microcontroller's resources, the implemented interface has daisy chain capability. Several (typically 6) 1EDI2004AS devices can be combined into a single SPI bus.

Functional Description

2.4.4.2 General Operation

The SPI interface of the 1EDI2004AS supports full duplex operation. The interface relies on four communication signals:

- **NCS:** (Not) Chip Select.
- **SCLK:** Serial Clock.
- **SDI:** Serial Data In.
- **SDO:** Serial Data Out.

The SPI interface of the 1EDI2004AS supports slave operation only. An SPI master (typically, the main microcontroller) is connected to one or several 1EDI2004AS devices, forming an SPI bus. Several bus topologies are supported.

A regular SPI bus topology can be used where each of the slaves is controlled by an individual chip select signal (Figure 6). In this case, the number of slaves on the bus is only limited by the application’s constraints.

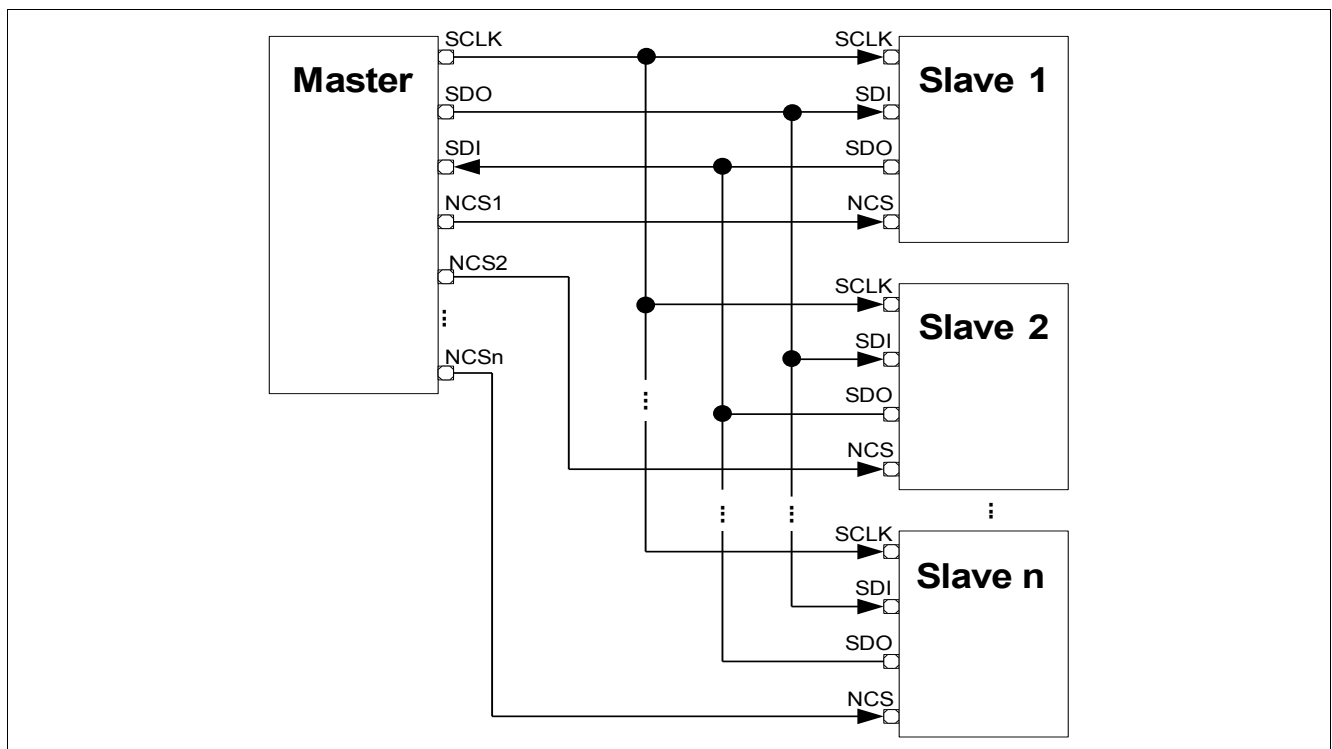

Figure 6 SPI Regular Bus Topology

In order to simplify the layout of the PCB and to reduce the number of pins used on the microcontroller’s side, a daisy chain topology can also be used. The chain’s depth is not limited by the 1EDI2004AS itself. A possible topology is shown Figure 7.

Functional Description

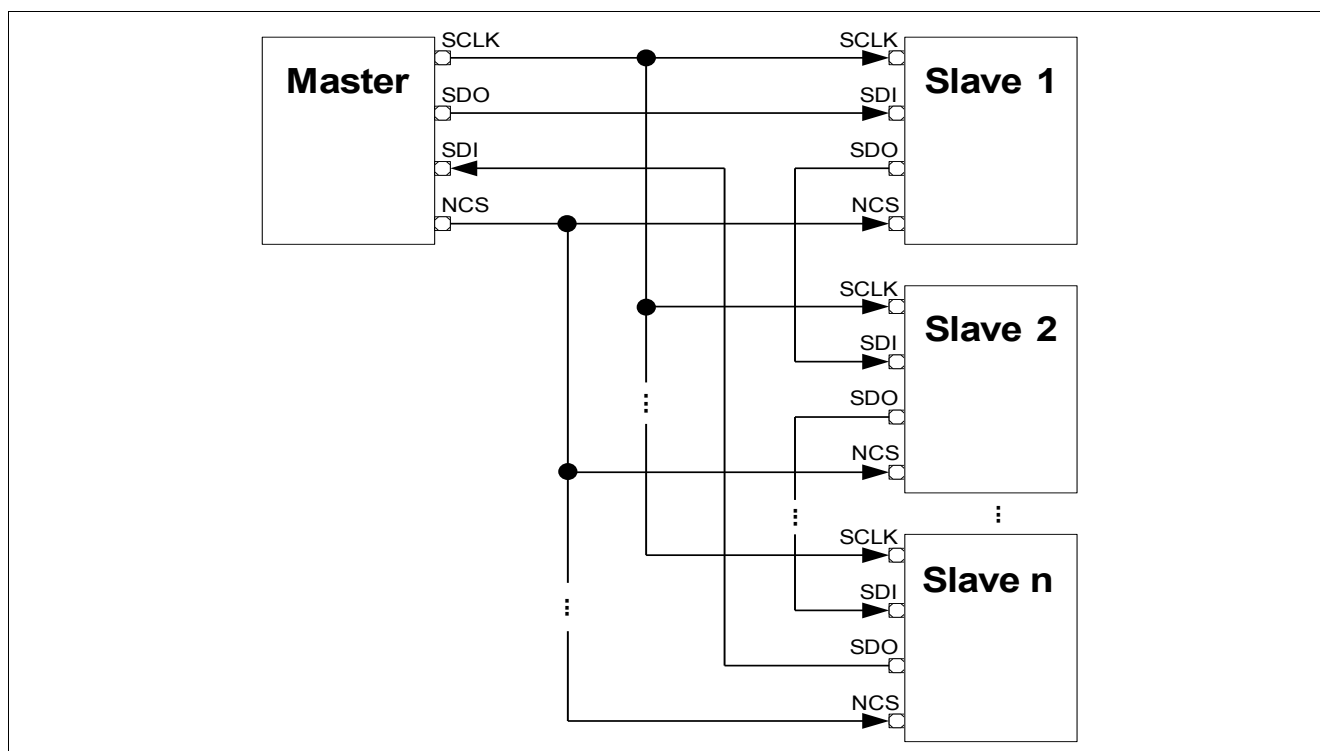

Figure 7 SPI Daisy Chain Bus Topology

Physical Layer

The SPI interface relies on two shift registers:

- A shift output register, reacting on the rising edges of **SCLK**.
- A shift input register, reacting on the falling edges of **SCLK**.

When signal **NCS** is inactive, the signals at pins **SCLK** and **SDI** are ignored. The output **SDO** is in tristate.

When **NCS** is activated, the shift output register is updated internally with the value requested by the previous SPI access.

At each rising edge of the **SCLK** signal (while **NCS** is active), the shift output register is serially shifted out by one bit on the **SDO** pin (MSB first). At each falling edge of the clock pulse, the data bit available at the input **SDI** is latched and serially shifted into the shift input register.

At the deactivation of **NCS**, the SPI logic checks how many rising and falling edges of the **SCLK** signal have been received. In case both counts differ and / or are not a multiple of 16, an SPI Error is generated. The SPI block then checks the validity of the received 16-bit word. In case of a non valid data, an SPI error is generated. In case no error is detected, the data is decoded by the internal logic.

The **NCS** signal is active low.

Input Debouncing Filters

The input stages of signals **SDI**, **SCLK**, and **NCS** include each a Debouncing Filter. The input signals are that way filtered from glitches and noise.

The input signals **SDI** and **SCLK** are analyzed at each edge of the internal clock derived from OSC1. If the same external signal value is sampled three times consecutively, the signal is considered as valid and is processed by the SPI logic. Otherwise, the transition is considered as a glitch and is discarded.

Functional Description

The input signal **NCS** is sampled at a rate corresponding to the period of the internal clock derived from OSC1. If the same external signal value is sampled two times consecutively, the signal is considered as valid and is processed by the SPI logic. Otherwise, the transition is considered as a glitch and is discarded.

2.4.4.3 Definitions

Command

A command is a high-level command issued by the SPI master which aims at generating a specific reaction in the addressed slave. The command is physically translated into a Request Message by the SPI master. The correct reception of the Request Message by the SPI slave leads to a specific action inside the slave and to the emission of an Answer Message by the slave.

Example: the READ command leads to the transfer of the value of the specified register from the device to the SPI master.

Word

A word is a 16-bit sequence of shifted data bits.

Transfer

A transfer is defined as the SPI data transfers (in both directions) occurring between a falling edge of **NCS** and the next consecutive rising edge of **NCS**.

Request Message

A request message is a word issued by the SPI master and addressing a single slave. A request message relates to a specific command.

Answer Message

An answer message is a well-defined word issued by a single SPI slave as a response to a request message.

Transmit Frame

A transmit frame is a sequence of one or several words sent by the SPI Master within one SPI transfer. In regular SPI topologies, a transmit frame is in practice identical to a data word. In daisy chain topologies, a transmit frame is a sequence of data words belonging to different request messages.

Receive Frame

A receive frame is a sequence of one or several words received by the SPI Master within one SPI transfer. In regular SPI topologies, a receive frame is in practice identical to a data word. In daisy chain topologies, a receive frame is a sequence of data words belonging to different Answer Messages.

The SPI protocol supported by the 1EDI2004AS is based on the Request / Answer principle. The master sends a defined request message to which the slave answers with the corresponding answer message (**Figure 8**, **Figure 9**). Due to the nature of the SPI interface, the Answer Message is shifted, compared to the Request Message, by one SPI transfer. It means, for example, that the last word of answer message *n* is transmitted by the slave while the master sends the first word of request message *n+1*.

Functional Description

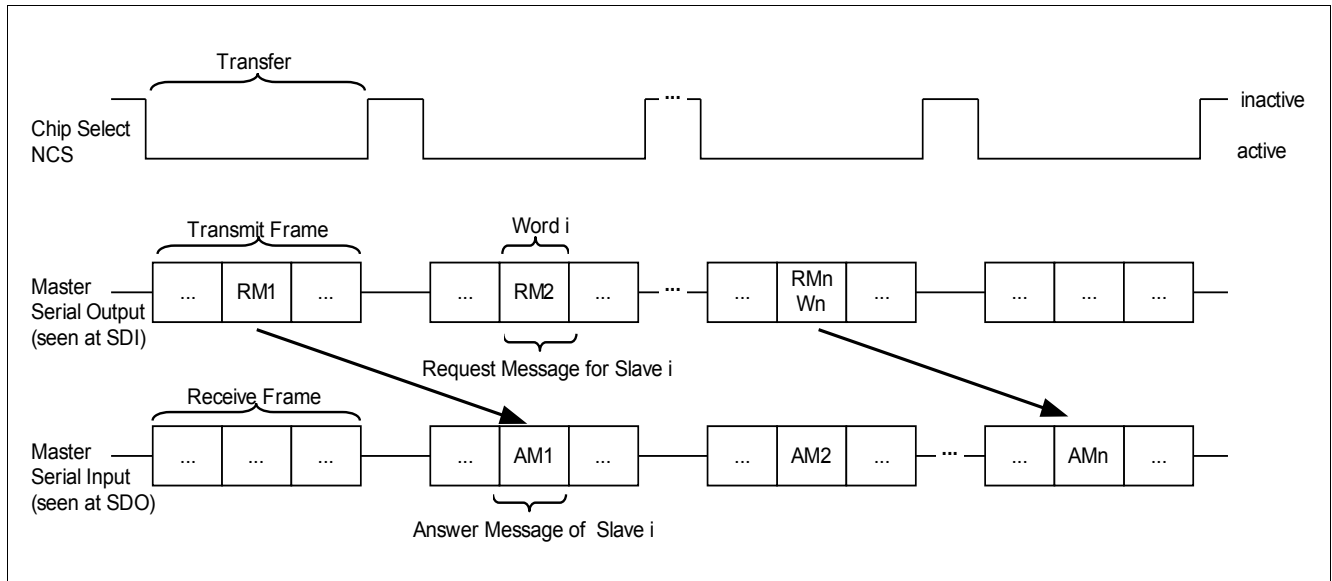

Figure 8 Response Answer Principle - Daisy Chain Topology

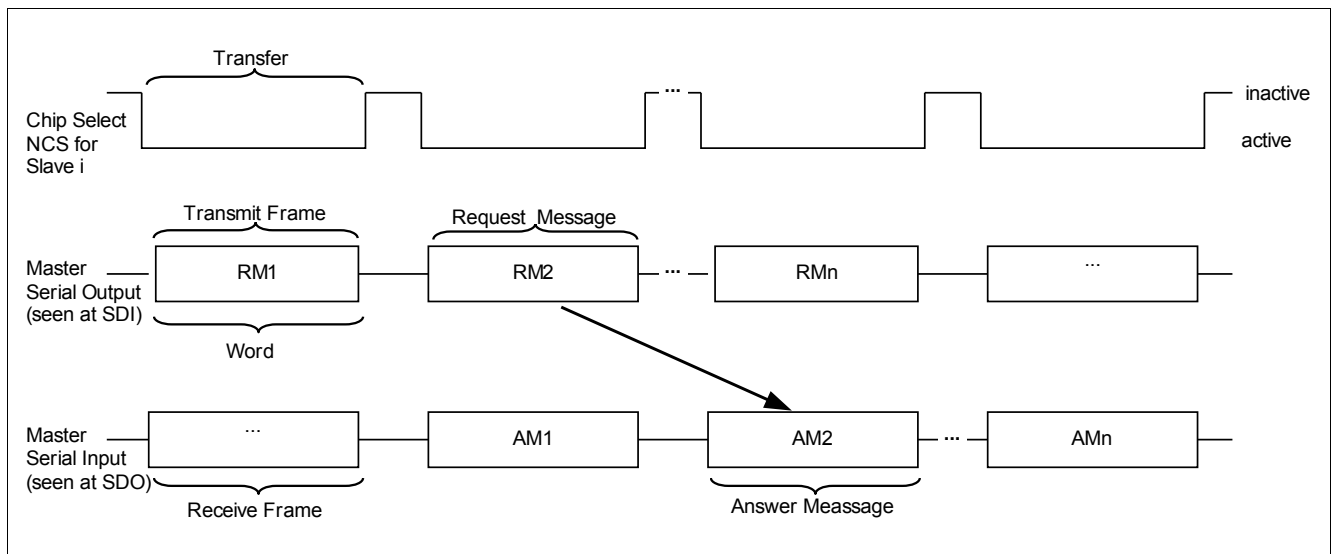

Figure 9 Response Answer Principle - Regular Topology

The first word transmitted by the device after power-up is the content of register **PSTAT**.

2.4.4.4 SPI Data Integrity Support

2.4.4.4.1 Parity Bit

By default, the SPI link relies on an odd parity protection scheme for each transmitted or received 16-bit word of the SPI message. The parity bit corresponds to the LSB of the 16-bit word. Therefore, the effective payload of a 16-bit word is 15 data bit (plus one parity bit). The parity bit check (on the received data) can be disabled by clearing bit **PCFG.PAREN**. In this case, the parity bit is considered as “don’t care”. The generation of the parity bit by the driver for transmitted words can not be disabled (but can be considered as “don’t care” by the SPI master).

Note: For fixed value commands (ENTER_CMODE, ENTER_VMODE, EXIT_CMODE, NOP), it has to be ensured that the value of the parity bit is correct even if parity check is disabled. Otherwise, an SPI error will be generated.

2.4.4.4.2 SPI Error

When the device is not able to process an incoming request message, an SPI error is generated: the received message is discarded by the driver, bit **PER.SPIER** is set and the erroneous message is answered with an error notification (bit **LMI** set).

Several failures generate an SPI error:

- A parity error is detected on the received word.
- An invalid data word format is received (e.g. not a 16 bit word).
- A word is received, which does not correspond to a valid Request Message.
- A command is received which can not be processed. For example, the driver receives in Active Mode a command which is only valid in other operating modes. Another typical example is a read access to the secondary while the previous read access is not yet completed (device “busy”).
- An SPI access to an invalid address.

*Note: the content of a frame with LMI bit set is the value of register **PSTAT**.*

*Note: In case of permanent LMI error induced by system failures, it is recommended to apply a reset via pin **NRST/RDY**.*

Functional Description

2.4.4.5 Protocol Description

2.4.4.5.1 Command Catalog

Table 3 gives an overview of the command catalog supported by the device. The full description of the commands and of the corresponding request and answer messages is provided in the following sections.

Table 3 SPI Command Catalog

Acronym	Short Description	Valid in Mode
ENTER_CMODE	Enters into Configuration Mode.	OPM0, OPM1
ENTER_VMODE	Enters into Verification Mode.	OPM2
EXIT_CMODE	Leaves Configuration Mode to enter into Configured Mode.	OPM2
READ	Reads the register value at the specified address.	All
NOP	Triggers no action in the device (equivalent to a “nop”).	All
WRITEH	Update the most significant byte of the internal write buffer.	All
WRITEL	Updates the least significant byte of the internal write buffer, and copies the contents of the complete buffer into the addressed register. The write buffer is cleared afterwards.	All (with restrictions)

An overview of the commands is given Figure 10.

Message	Command				Data												P	
ENTER_CMODE	0	0	0	1	1	0	0	0	1	0	0	0	0	0	0	0	0	0
ENTER_VMODE	0	0	0	1	0	0	0	1	0	1	0	0	0	0	0	0	0	0
EXIT_CMODE	0	0	0	1	0	0	1	0	0	0	1	0	0	0	0	0	0	0
NOP	0	0	0	1	0	1	0	0	0	0	0	1	0	0	0	0	0	0
READ	0	0	0	0	A4	A3	A2	A1	A0	0	1	0	1	0	1	0	1	X
WRITEH	0	1	0	0	0	1	0	D15	D14	D13	D12	D11	D10	D9	D8	D7	X	
WRITEL	1	0	1	0	A4	A3	A2	A1	A0	D7	D6	D5	D4	D3	D2	D1	X	

Figure 10 SPI Commands Overview

2.4.4.5.2 Word Convention

In order to simplify the description of the SPI commands, the following conventions are used (Table 4).

Functional Description

Table 4 Word Convention

Acronym	Value
Va(REGISTER)	Value of register REGISTER
P _B	Parity Bit
<<n	Left shift operation of n bits.
x _H y _H	Result of the operation: x _H OR y _H

2.4.4.5.3 ENTER_CMODE Command

The goal of this function is to set the device into Configuration Mode. After reception of a valid ENTER_CMODE command, mode OPM2 is active. This command is only valid in Default Mode (OPM0 and OPM1). In case the request message is received while OPM0 or OPM1 is not active, the complete command is discarded and an SPI error occurs.

[Table 5](#) describes the request message and the corresponding answer message.

Table 5 ENTER_CMODE request and answer messages

	Transfer 1	Transfer 2
Request message	1880 _H	N.a.
Answer message	N.a.	Va(PSTAT)

2.4.4.5.4 ENTER_VMODE Command

The goal of this function is to set the device into Verification Mode. After reception of a valid ENTER_VMODE command, mode OPM5 is active. This command is only valid in Configuration Mode (OPM2). In case the request message is received while OPM2 is not active, the complete command is discarded and an SPI error occurs.

[Table 6](#) describes the request message and the corresponding answer message.

Table 6 ENTER_VMODE request and answer messages

	Transfer 1	Transfer 2
Request message	1140 _H	N.a.
Answer message	N.a.	Va(PSTAT)

2.4.4.5.5 EXIT_CMODE Command

When a valid EXIT_CMODE is received by the device, the Configuration Mode is left to Configured Mode (Mode OPM3 active). This command is only valid in Configuration Mode (OPM2). In case the request message is received while OPM2 is not active, the complete command is discarded and an SPI error occurs.

[Table 7](#) describes the request message and the corresponding answer message.

Functional Description

Table 7 EXIT_CMODE request and answer messages

	Transfer 1	Transfer 2
Request message	1220 _H	N.a.
Answer message	N.a.	Va(PSTAT)

2.4.4.5.6 NOP Command

This command triggers no specific action in the driver (equivalent to a “nop”). However, the mechanisms verifying the validity of the word are active. This command is valid in all operating modes.

[Table 8](#) describes the request message and the corresponding answer message.

Table 8 NOP request and answer messages

	Transfer 1	Transfer 2
Request message	1410 _H	N.a.
Answer message	N.a.	Va(PSTAT)

2.4.4.5.7 READ Command

This command aims at reading the value of the register whose address is specified in the request message. This command is valid in all operating modes. However, in OPM4 and OPM6, the use of the READ command is restricted (see [Table 37](#)). If an access outside the allowed address range is performed, the access is discarded as invalid and an SPI error occurs.

[Table 9](#) describes the request message and the corresponding answer message.

Table 9 READ request and answer messages

	Transfer 1	Transfer 2
Request message	See below	N.a.
Answer message	N.a.	Va(Register)

Request message words

Word 1: (ADDRESS_5BIT << 7) | 002A_H | P_B.

Answer message words

Word 1: Value of REGISTER.

2.4.4.5.8 WRITEH

This command aims at writing the upper byte of the internal write buffer with the specified value. This command has no other effect on the functionality of the device. This command is valid in all operating modes.

[Table 10](#) describes the request message and the corresponding answer message.

Functional Description

Table 10 WRITEH request and answer messages

	Transfer 1	Transfer 2
Request message	See below	N.a.
Answer message	N.a.	Va(PSTAT)

Request message words

Word 1: $4400_H | (DATA_8BIT \ll 1) | P_B$

2.4.4.5.9 WRITEL

This command aims at updating the value of the register whose address is specified in the request message. This command is valid in all operating modes. However, depending on the active operating mode, this command is restricted to a given address range or specific registers (see [Table 38](#)). If an access outside the allowed address range is performed, the access is discarded as invalid and an SPI error occurs.

At the reception of this command, the least significant byte of the internal buffer is written with the specified value, the contents of the buffer is copied to the register at the specified address and the complete write buffer is cleared.

[Table 11](#) describes the request message and the corresponding answer message.

Table 11 WRITEL request and answer messages

	Transfer 1	Transfer 2
Request message	See below	N.a.
Answer message	N.a.	Va(PSTAT)

Request message words

Word 1: $A000_H | (ADDRESS_5BIT \ll 7) | (DATA_6BIT \ll 1) | P_B$.

Functional Description

2.4.5 Operating Modes

2.4.5.1 General Operation

At any time, the driver can be in one out of seven possible operating modes:

- OPM0: Default Mode (default after reset, device is disabled).
- OPM1: Error Mode (reached after Event Class B, device is disabled).
- OPM2: Configuration Mode (device is disabled, configuration of the device can be modified).
- OPM3: Configured Mode (device is configured and disabled).
- OPM4: Active Mode (normal operation).
- OPM5: Verification mode (intrusive diagnostic functions can be triggered).
- OPM6: Weak active mode (the device can be turned on but with restrictions)

The current active mode of the device is given by bit field **SSTAT.OPM**.

The concept of the device is based on the following general ideas:

- The driver can only switch the IGBT on when OPM4 mode is active (exception: weak-turn on in OPM6).
- Starting from Mode OPM0 or OPM1, the Active Mode OPM4 can only be activated through a dedicated SPI command sequence and the activation of the hardware signal **EN**. As a result, the probability that the device goes to OPM4 mode due to random signals is negligible.
- Differentiations of errors: different classes of errors are defined, leading to different behavior of the device.

The state diagram for the operating modes is given in **Figure 11**:

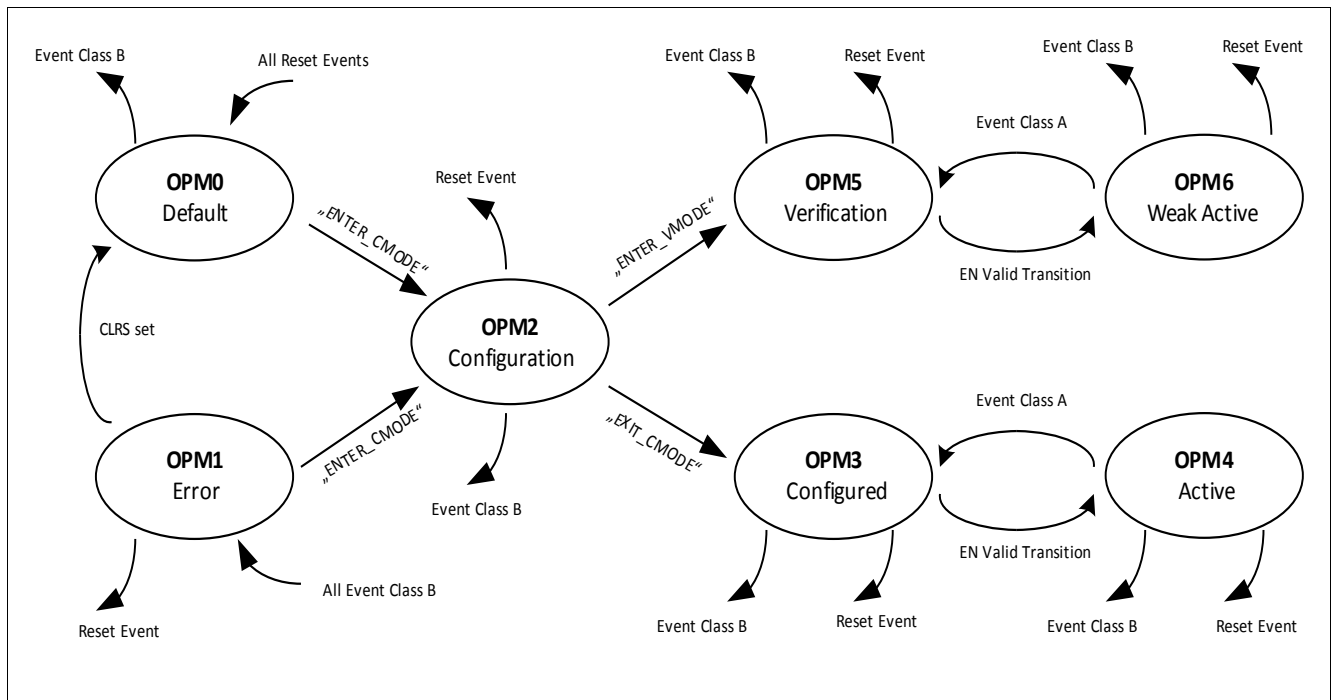

Figure 11 Operating Modes State Diagram

Functional Description

2.4.5.2 Definitions

2.4.5.2.1 Events and State Transitions

The transitions from one state to the other are based on “events” and / or SPI commands. The following classification is chosen for defining the events.

Events Class A

The following (exhaustive) list of events are defined as Events Class A:

- Occurrence of a DESAT event (leads to a safe turn-off sequence).
- Occurrence of an OCP event (leads to a safe turn-off sequence).
- Valid to Invalid transition on **EN** signal (leads to a regular turn-off sequence).

When an Event Class A occurs, the output stage initiates either a safe turn-off sequence (DESAT, OCP) or a regular turn-off sequence (**EN** event). The event is notified via an error bit in the corresponding register.

Note: Contrarily to a reset event, an Event Class A does not affect the contents of the configuration registers.

When an Event Class A occurs, the device may change its operating mode depending on which mode is active when the event occurs:

- If it was in OPM4, it goes in OPM3.
- If it was in OPM6, it goes in OPM5.

In all other cases, the OPM is unaffected. A state transition due to an Event Class A leads to the activation of signal **NFLTA**. If no state transition occurs (if for example the device was not in OPM4 or OPM6), **NFLTA** is not activated.

Events Class B

The following (exhaustive) list of events are defined as Events Class B:

- Occurrence of a UVLO2 event.
- Occurrence of a OVLO2 event.
- Occurrence of a UVLO3 event. (configurable)
- Occurrence of a OVLO3 event. (configurable)
- Verification Mode Time Out Error

Note: Every class B event with state transition triggers a notification via NFLTB signal. But not all notifications on NFLTB signal are class B events (e.g. failures, resets, also see [Table 14](#), [Table 15](#)).

When an Event Class B occurs, the output stage initiates a regular turn-off sequence. The event is notified via an error bit in the corresponding register and (possibly) via the signal **NFLTB**.

Note: Events Class B may affect the contents of the configuration registers.

When an Event Class B occurs, the device may change its operating mode depending on which mode is active when the event occurs: if it was not in OPM1, it goes to OPM1. It is unaffected otherwise

Functional Description

A state transition due to an Event Class B leads to the activation of signal **NFLT**. If no state transition occurs (if for example the device was already in OPM1), **NFLT** is not activated. See [Chapter 2.4.7](#) for more details on failure notifications.

Events Class C

Generally speaking, Events Class C are error events that do not lead to a change of the operating mode of the device. The following (exhaustive) list of events is comprised within the Event Class C:

- Time Out Error ([PER.O2MTO](#) & [PER.DBTO](#))
- Output Stage Tristate ([PER.OSTER](#))
- SPI Error ([PER.SPIER](#)).
- Shoot Through Protection Error ([PER.STPER](#)).

Note: For over- and undervoltage errors it is depending on the configuration whether a Event Class B or Event Class C is generated (e.g. [SER.OVLO3ER](#), [SER.OVLO2ER](#))

SPI Commands

The following SPI commands have an impact on the device's operating mode. The SPI commands are described in [Chapter 2.4.4.5](#).

- ENTER_CMODE.
- ENTER_VMODE.
- EXIT_CMODE.
- Setting of bit [SCTRL.CLRS](#) (by writing register [PCTRL](#))

Reset Events

A reset sets the device (or part of the device) in its default state. Reset events are described in [Chapter 2.4.10](#).

2.4.5.2.2 Emergency Turn-Off Sequence

The denomination “Emergency Turn-Off Sequence” (ETO) is used to describe the sequence of actions executed by the output stage of the device when an Event Class A and Class B is detected.

An ETO sequence is described by the following set of actions:

- A Turn-Off sequence is initiated. In case of DESAT or OCP event, a safe turn-off sequence is initiated. For the other events, a regular turn-off sequence is initiated.
- The device enters the corresponding OPM mode. As a consequence, the device is disabled.

Once an ETO from Event Class B has been initiated, the device can not be reenabled. Consequently, the user need to reconfigure the device before reenabling the device and sending PWM turn-on command.

2.4.5.2.3 Ready, Disabled, Enabled and Active State

The device is said to be in Ready state in case no reset event is active on the primary chip. When the device is Ready, signal **NRST/RDY** is at High level.

Functional Description

When the device is in Disabled State, the PWM turn-on commands are ignored. This means that whatever the input signal **INP** is, the output stage (if not tristated) delivers a constant turn-off signal to the IGBT. Unless otherwise stated, all other functions of the device work normally.

When the device is not in Disabled State, it is said to be in Enabled State. In this case, the PWM signal command is processed normally (if the output stage is not tristated). Practically, the device is in Enabled State when either Mode OPM4 or Mode OPM6 is active.

Active State corresponds to the normal operating state of the device. Practically, the device is in Active State when Mode OPM4 is active.

Note: When the device is in Active State, it implicates it is in Enabled state.

2.4.5.3 Operation Modes Description

Default Mode (OPM0)

Mode OPM0 is the default operating mode of the device after power up or after a reset event. In OPM0, the device is in Disabled State.

The following exhaustive list of events bring the device in OPM0 Mode:

- Occurrence of a Reset Event.
- Bit **SCTRL.CLRS** set while the device was in OPM1.

Error Mode (OPM1)

Mode OPM1 is the operating mode of the device after an Event Class B.

The following exhaustive list of events bring the device in OPM1 Mode:

- Occurrence of an Event Class B.

In OPM1, when bit **SCTRL.CLRS** is set via the corresponding SPI command, the device shall normally jump to OPM0. However, in case the conditions for an Event Class B are met at that moment, no state transition occurs and the device stays in OPM1. The operation of bit **SCTRL.CLRS** on the secondary sticky bits works normally.

In OPM1, when a valid ENTER_CMODE command is received, the device shall normally jump to OPM2. However, in case the conditions for an Event Class B are met at that moment, no state transition occurs and the device stays in OPM1 for the duration of the event. The state transition to OPM2 is executed as soon as the conditions leading to the Event Class B disappear. It shall be noted that no LMI error notification is issued.

Configuration Mode (OPM2)

Configuration Mode is the mode where the configuration of the device can be modified. When OPM2 is active, the device is in Disabled State.

The following exhaustive list of events bring the device in Configuration Mode:

- Reception of a valid ENTER_CMODE command **while** Mode OPM0 or OPM1 active.

Functional Description

Configured Mode (OPM3)

Configured Mode is the mode where the device is ready to be enabled. When OPM3 is active, the device is in Disabled State.

The following exhaustive list of events bring the device in Mode OPM3:

- Reception of a valid EXIT_CMODE command **while** Mode OPM2 active.
- Event Class A **while** Mode OPM4 active.

Active Mode (OPM4)

The Active Mode corresponds to the normal operating mode of the device. When OPM4 is active, the device is in Active State. The following exhaustive list of event bring the device in Active Mode:

- Invalid to Valid Transition on signal **EN** **while** Mode OPM3 active.

Verification Mode (OPM5)

Verification Mode is the mode where intrusive verification functions can be started. When OPM5 is active, the device is in disabled state.

The following exhaustive list of event bring the device in Verification Mode:

- Reception of a valid ENTER_VMODE command **while** Mode OPM2 active.
- Occurrence of an Event Class A **while** Mode OPM6 active.

After a transition from Mode OPM2 to OPM5, an internal watchdog timer is started. If after time t_{VMTO} , the device has not left both modes OPM5 or OPM6, a time-out event occurs and an Event Class B is generated.

Weak Active Mode (OPM6)

Weak Active Mode is the mode where the device can be activated to run diagnosis tests at system level. When OPM6 is active, the device is in Enabled State. A PWM turn-on command issues a Weak Turn-On on the secondary side.

The following exhaustive list of event bring the device in Weak Active Mode:

- Invalid to Valid Transition on signal **EN** **while** Mode OPM5 active.

The watchdog counter started when entering Mode OPM5 is not reset when entering OPM6.

Implementation Notes related to State Transitions

- An Event Class A or Class B detected on the secondary side lead to an immediate reaction of the device's output stage. Due to the latency of the inter-chip communication, the notification on the primary side is slightly delayed.
- The activation of signal **NFLTA** or **NFLTB** is simultaneous to the corresponding state transition on the primary side.
- It is possible to change the operating mode while a failure condition is present. This may however lead to a new immediate error notification and state transition.

2.4.5.4 Activating the device after reset

After a reset event, the device is in Mode OPM0 and disabled. In order to be active, the device needs to enter Configuration Mode with the ENTER_CMODE command. Once all the configurations have been performed, the Configuration Mode has to be exited with an EXIT_CMODE command. Once this is done, the device can enter the Active Mode when Invalid to Valid transition on pin EN is detected.

2.4.5.5 Activating the device after an Event Class A or B

If during operation, an Event Class A occurs, the device enters the OPM3 (or OPM5). Bit field SSTAT.OPM is updated accordingly. In order to reactivate the device, an invalid-to-valid transition has to be applied to signal EN. It means that a Low-level and then a High level is applied to EN. If no Event Class A event is active, the device will enter OPM4 (respectively OPM6).

If during operation, an Event Class B occurs, the device enters the Default Mode OPM1. Bit field SSTAT.OPM is updated accordingly. In order to reactivate the device, the steps defined in Chapter 2.4.5.4 need to be performed.

2.4.5.6 Debug Mode

The DEBUG pin gives the possibility to operate the device in the so-called Debug Mode. The goal of the Debug Mode is to operate the device without SPI interface. This mode should be used for development purpose only and is not intended to be used in final applications.

At V_{CC2} power-on, the level at pin DEBUG is latched. In case a High level is detected, the device enters the Debug Mode. Bit SSTAT.DBG is then set.

In Debug Mode, the regular operation of the internal state machine is modified, so that the device can only enter OPM3 or OPM4. As a result Modes OPM0, OPM1, OPM2, OPM5 and OPM6 are completely bypassed. In case of a Reset event, the device goes to OPM3 (instead of OPM0). Besides, in Debug Mode, events leading normally to an Event Class B are replaced an Event Class A, resulting in the activation of signal NFLTA. Event Class B are therefore not generated by the device in Debug Mode (and signal NFLTB shall not be used).

It should be noted that the configuration of the device in Debug Mode corresponds to the default settings and can not be changed (refer to the register reset values to get the default configuration).

In Debug Mode, the operation of the device is otherwise similar to regular operation. It means in particular that the signal EN has to be managed properly: when the device is in OPM3, a Low to High level transition has to be applied to the device in order to enter OPM4 (Active Mode).

Note: Once it has been latched at power-on, the level on the pin DEBUG has no impact on the device until the next power-on event on the secondary side.

Functional Description

2.4.6 Driver Functionality

The structure of the output stage and its associated external booster of the device is depicted [Figure 12](#):

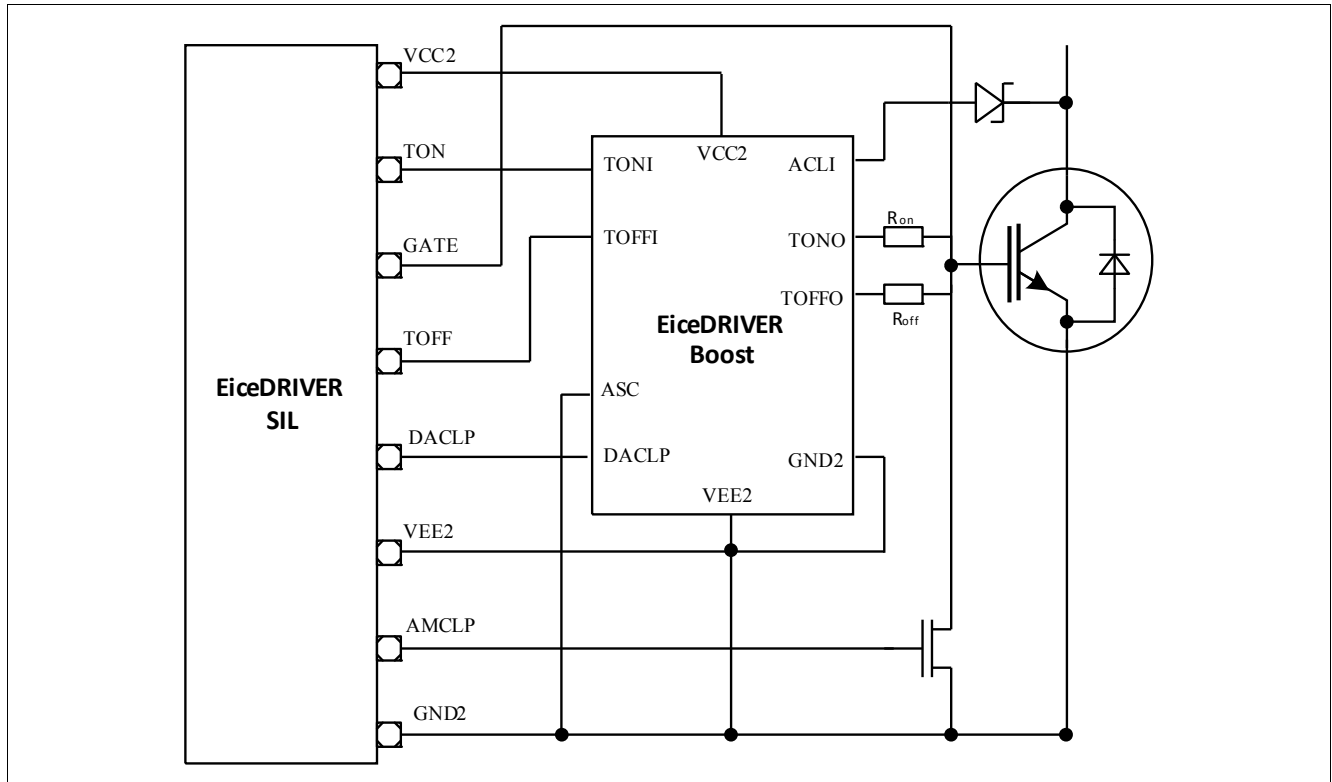

Figure 12 Output Stage Diagram of Principle

Note: *AMCLP usage is recommended at unipolar supply.*

Note: *For usage without EiceDRIVER Boost Infineon takes no responsibilities for any cross currents.*

2.4.6.1 Overview

Two turn-off behaviors are supported by the device, depending on the event causing the turn-off action.

- Regular Turn-Off.
- Safe Turn-Off.

A Safe Turn-Off sequence uses the timing and plateau level parameters defined in register [SSTOF](#). It is triggered by a DESAT or an OCP event only. A turn-off sequence which is not “Safe” is then “Regular”. A Regular Turn-Off sequence uses the timing defined in register [SRTTOF](#).

Two Level Turn-Off (TTOFF)

Because a hard turn-off may generate a critical overvoltage on the IGBT leading eventually to its destruction, the 1EDI2004AS supports the Two Level Turn-Off functionality (TTOFF). The TTOFF function consists in switching the IGBT off in three steps in such a way that:

1. The IGBT gate voltage is first decreased with a reduced slew rate until a specific (and programmable) voltage is reached by the [TOFF](#) signal.
2. [TOFF](#) (and [TON](#)) voltage is stabilized at this level. The IGBT Gate voltage forms thus a plateau.
3. Finally, the switch-off sequence is resumed using hard commutation.

Functional Description

The TTOFF delays and plateau voltage are fully programmable using the corresponding SPI commands. Too small delays will not be visible as plateau on the output signal, but may change the slew rate from V_{CC2} to plateau. For a Regular Turn-Off sequence, the TTOFF delay is defined by bit field **SRTTOF.RTVAL**. Setting this field to 00_H completely disables the TTOFF function for all Regular Turn-Off sequences (but this has no effect on Safe Turn-Off sequences). The plateau level is defined by **SRTTOF.GPR**. If this function is to be activated, a sufficient value for the delay time has to be programmed.

For a Safe Turn-Off sequence, the TTOFF delay is defined by bit field **SSTTOF.STVAL**. Setting this field to 00_H completely disables the TTOFF function for all Safe Turn-Off sequences (but this has no effect on Regular Turn-Off sequences). If this function is to be activated, a sufficient value for the delay time has to be programmed. The plateau level is defined by **SSTTOF.GPS**.

The timing of a Safe Turn-Off event is in the clock domain of the main secondary oscillator (OSC2). The timing of a Regular Turn-Off event is in the clock domain of the Start-Stop Oscillator (SSOSC2), leading to high accuracy and low PWM distortion

When using the TTOFF function (with a non-zero delay), the PWM command is received on pin **INP** is delayed by the programmed delay time (**Figure 13**).

For pulses larger than the TTOFF delay ($t_{PULSE} > t_{TTOFF} + t_{AMCDeI} + 1/2$ SSOSC cycles), the output pulse width is kept identical to the input pulse width.

For smaller pulses ($t_{PULSE} < t_{TTOFF} + t_{AMCDeI} + 1/2$ SSOSC cycles), the output pulse is identical to the programmed delay. The minimum pulse width delivered by the device to the IGBT is therefore the programmed delay time extended by two SSOSC cycles.

The device allows for external booster voltage compensation at the IGBT gate. When bit **SCFG.VBEC** is cleared, the voltage at **TOFF** at the plateau corresponds to the programmed value. When bit **SCFG.VBEC** is set, an additional V_{BE} (base emitter junction voltage of an internal pn diode) is subtracted from the programmed voltage at **TOFF** in order to compensate for the V_{BE} of an external booster.

Functional Description

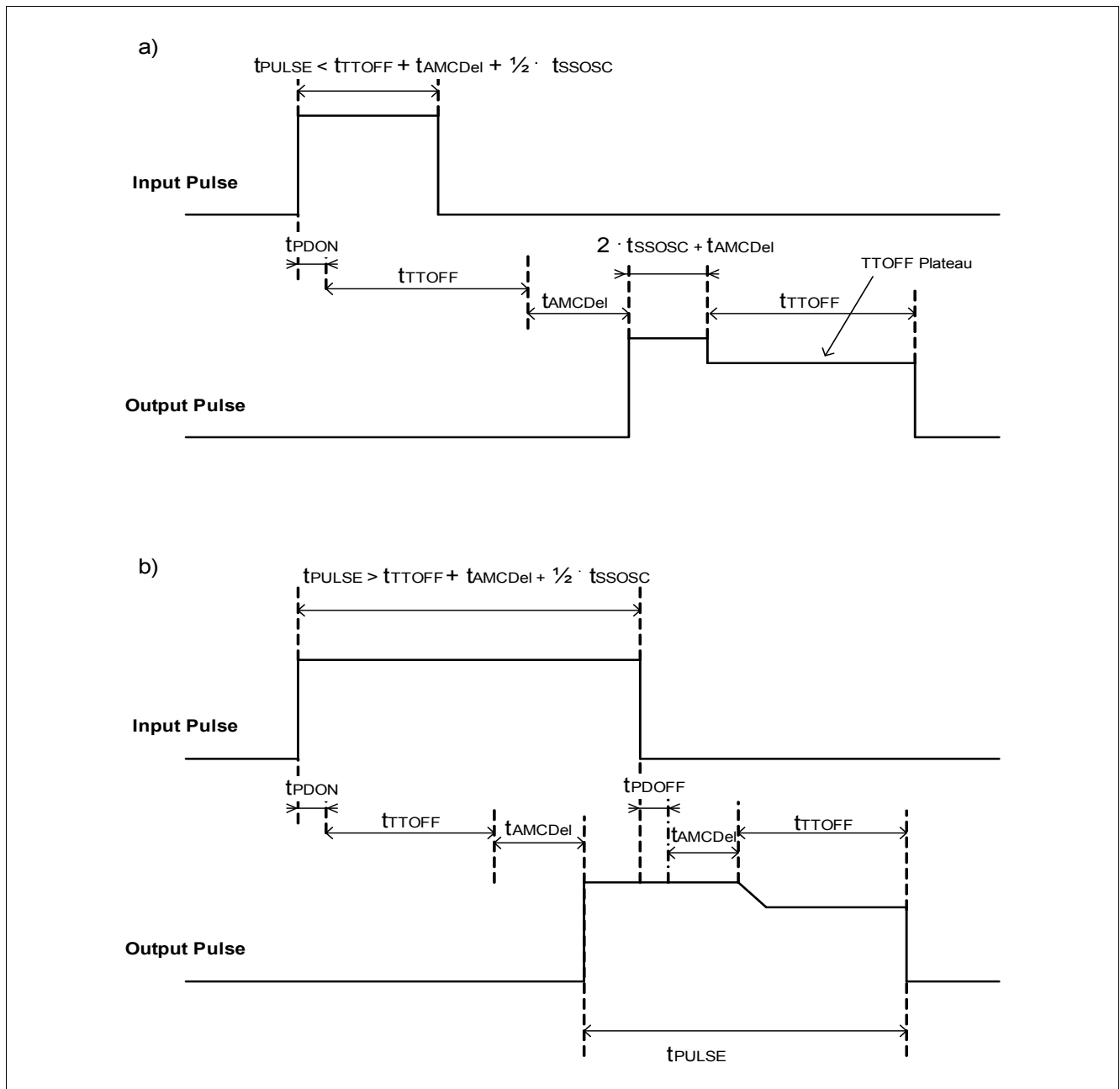

Figure 13 TTOFF: Principle of Operation

Pulse Suppressor

In order to increase the device’s robustness against external disturbances, a pulse suppressor can be enabled by setting bit **SCFG.PSEN**. Register **SRTTOF** shall also be programmed with a value higher than 2_{H_1} . When a PWM turn-on sequence occurs, the activation of the output stage is delayed by the programmed TTOFF number of cycles, as for a normal TTOFF sequence. However, the PWM command received by the secondary chip signal is internally sampled at every SSOSC cycle before the actual turn-on command is executed by the output stage. If at least one of the sampling points does not detect a high level, the turn-on sequence is aborted and the device is not switched on.

In case a valid PWM ON command is detected by the secondary side after the decision point the previous sequence has been aborted, a new turn-on sequence is initiated.

One of the consequences of activating the pulse suppressor is that all PWM pulses shorter than the programmed TTOFF plateau time are filtered out (Figure 14).

Functional Description

Note: The Pulse Suppressor only acts on turn-on pulses, not on turn-off pulses.

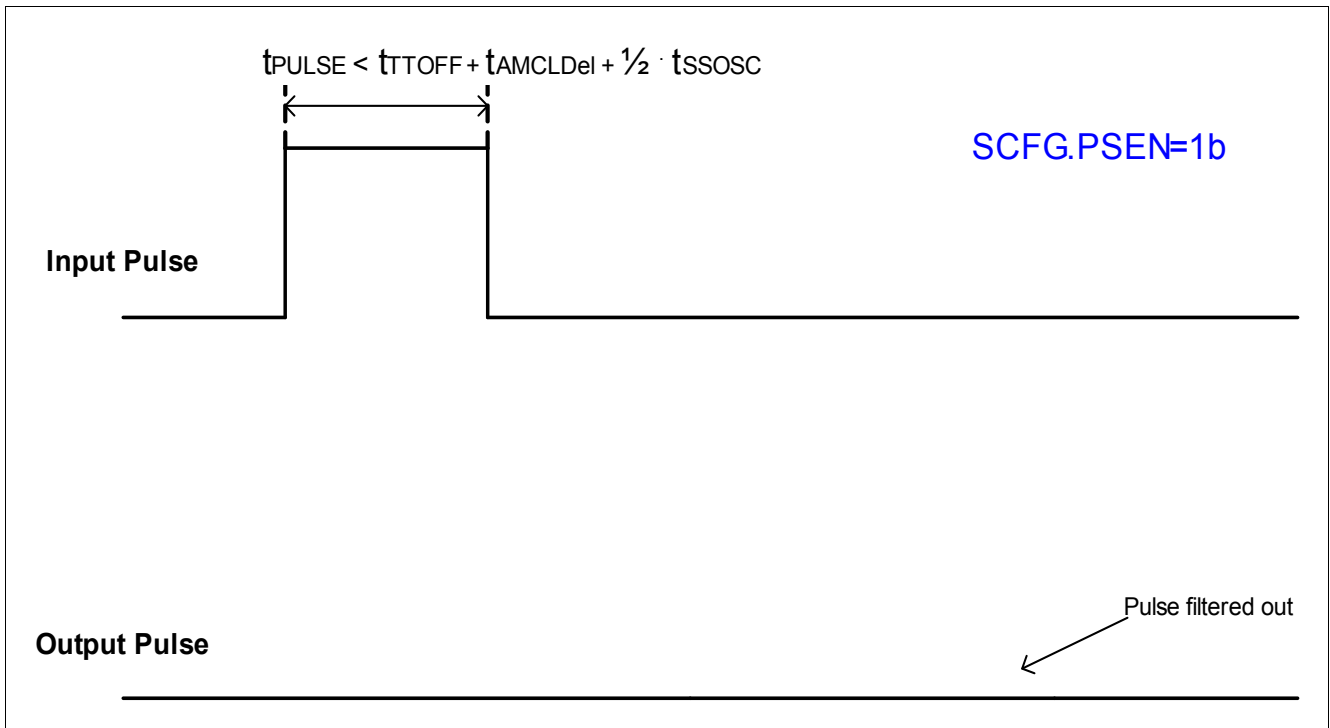

Figure 14 TTOFF: pulse suppressor aborting a turn-on sequence

Functional Description

2.4.6.2 Switching Sequence Description

Figure 15 shows an idealized switching sequence. When a valid turn-on command is detected, a certain propagation time t_{PDON} is needed by the logic to transfer the PWM command to the secondary side. At this point the TTOFF delay time t_{TTOFF} defined by bit field **SRTTOF.RTVAL** is added before the turn-on command is executed. Signal **TON** is then activated, while signal **TOFF** is deactivated.

When a valid turn-off command is detected, a certain propagation time t_{DOFF} is needed by the command to be processed by the logic on the secondary side. This propagation time depends on the event having generated the turn-off action (non exhaustive list):

- In case of a PWM turn-off command at pin **INP**, $t_{DOFF}=t_{PDOFF}$.
- In case of a DESAT Event, $t_{DOFF}=t_{OFFDESAT2}$.
- In case of an OCP event, $t_{DOFF}=t_{OFFOCP2}$.
- In case of an Event Class A on the primary side: $t_{DOFF}=t_{OFFCLA}$.
- In case of an Event Class B on the secondary side: $t_{DOFF}=t_{OFFCLB2}$.

Note: The timing t_{DOFF} doesn't consider the **SCFG.AMCLD** setting (**Figure 16**). The regular turn-on/off processing will be delayed by the **SCFG.AMCLD** value if setting is > 0 (refer to **Table 59**).

When the turn-off command is processed by the logic, signal **DACLP** is deactivated (i.e. active clamping is enabled). Signal **TON** and **TOFF** are decreased with the slew rate t_{SLEW} fixed by hardware. Once the voltage at pin **TOFF** has reached the value defined by bit field **SRTTOF.GPR**(or **SSTTOF.GPS** in the case of a safe turn-off), the turn-off sequence is interrupted. Time t_{TTOFF} is defined as the moment when the device starts turning off signal **TOFF**, and the moment where the turn-off sequence is resumed. Depending on the event that triggered the turn-off sequence, t_{TTOFF} is given by either bit field **SRTTOF.RTVAL** or **SSTTOF.STVAL**. Once the TTOFF time has elapsed, a hard commutation takes place, and signals **TON** and **TOFF** are driven to V_{EE2} .

Note: Once a turn-off sequence is started, it is completed to the end with the same delay parameters.

At the moment when the hard commutation takes place, signal **DACLP** remains deactivated for time t_{ACL} defined by bit field **SACLT.AT**. When this time is elapsed, signal **DACLP** is reactivated (i.e. active clamping is disabled).

In case **SACLT.AT** is set to 0_H , **DACLP** is constantly activated (constant High level). In case **SACLT.AT** is set to FF_H , **DACLP** is constantly at Low level.

Functional Description

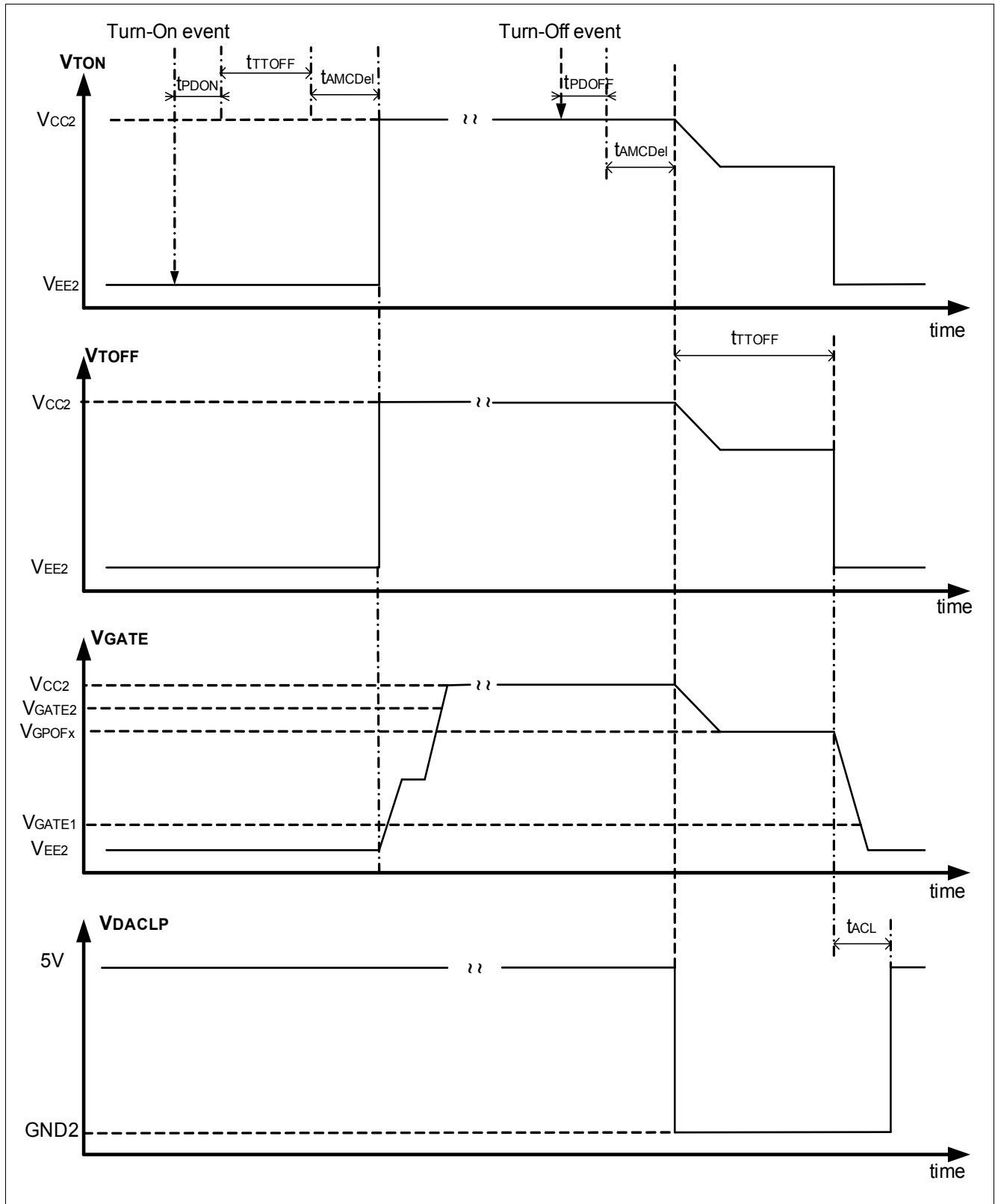

Figure 15 Idealized Switching Sequence (Regular Turn-Off)

Functional Description

2.4.6.3 Active Miller Clamping Transistor Clamping

The device can be configured to generate via pin **AMCLP** a control signal for an external Miller clamp transistor. During turn-off, when the gate signal reaches a voltage below V_{GATE1L} , **AMCLP** goes high.

At turn-on, in order to avoid the risk of cross-current in the output stage of the device, a delay can be generated in order to delay the PWM control signal (Figure 16). The delay is configured via bit field **SCFG.AMCLD**.

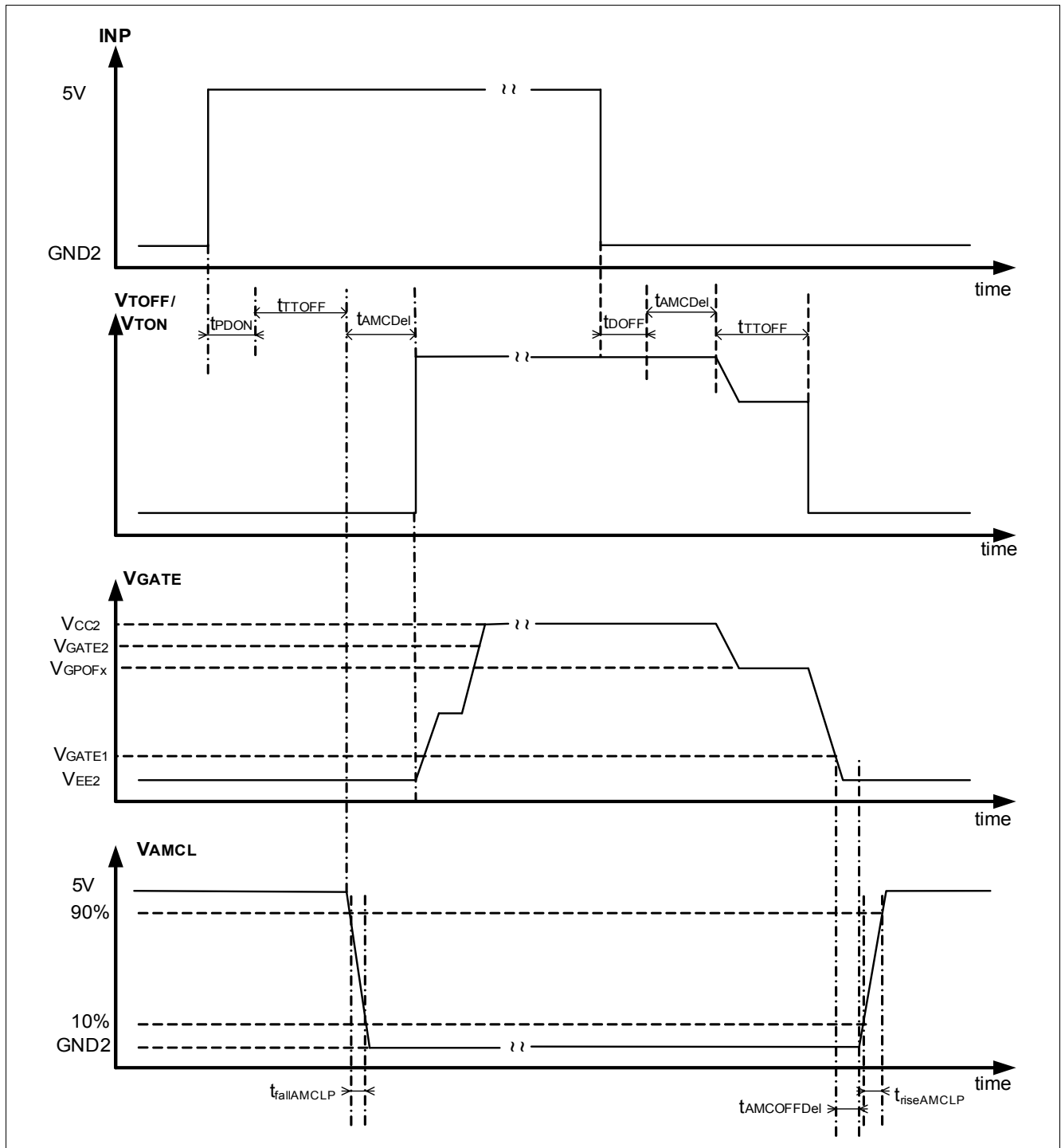

Figure 16 AMCLP operation

Functional Description

2.4.6.4 Disabling the output stage

The output stage of the device can be disabled, i.e. tristated by applying a High Level at pin **OSD**.

The current state of the output stage is indicated by bit **SSTAT.HZ**. If the bit is cleared, the output stage operates normally and issues a High or a Low level. If it is set, signals **TON** and **TOFF** are tristated.

When bit **SSTAT.HZ** is set, sticky bit **SER.OSTER** is set.

OSD Signal

The input signal **OSD** is used as a control signal in order to tristate the output stage of the device. A Low level at pin **OSD** corresponds to the normal operation of the device. When signal **OSD** is at High level, the output stage is tristated and the **AMCLP** signal is asserted to low.

Attention: *During OSD active the DESAT function is not enabled.*

Note: *DACL pin is not affected by OSD switching.*

The level read by the device at pin **OSD** is given by bit **SSTAT2.OSDL**.

The OSD function is interlocked with the passive clamping function, described in [Chapter 2.4.6.5](#). In that way if a voltage drop occur during OSD active, OSD will work until voltage is too small (passive clamping takes over) and repeat working after voltage is high enough again.

2.4.6.5 Passive Clamping

When the secondary chip is not supplied, signals **TOFF**, **TON** and **GATE** are clamped to V_{EE2} . See [Chapter 5.5.4](#) for the electrical capability of this feature.

Functional Description

2.4.7 Fault Notifications

The device provides two kinds of fault notification mechanisms:

- Pins **NFLTA**, **NFLTB** and **NRST/RDY** allow for fast error notification to the main microcontroller. All signals are active low.
- Error bits can be read by SPI.

The activation of signal **NRST/RDY** is associated with Reset Events (see [Chapter 2.4.10](#)). The activation of signal **NFLTA** is associated with Class A Events. The activation of signal **NFLTB** is associated with Class B Events. In general the activation of signal **NFLTA** or **NFLTB** is linked to a state transition of the state machine.

Notification of Event Class A

Events Class A are defined in [Chapter 2.4.5.2.1](#).

In case of a DESAT event (generating an Event Class A) is detected by the secondary side of the device, bit **SSTAT.FLTAS** is set for the duration of the failure condition. Due to the transient nature of the DESAT conditions, it might not be possible to observe a change of the state of bits **SSTAT.FLTAS**

Bit **SSTAT.FLTAS** is mirrored automatically to bit **PSTAT2.FLTAP**.

The general rule related to **NFLTA** activation is an Event Class A occurs that leads to a state transition (from OPM4 to OPM3 or OPM6 to OPM5), signal **NFLTA** is activated. In case an Event Class A occurs that does not lead to a state transition, **NFLTA** is not activated (exception: tristate events). However, the corresponding error bit in register **PER** or **SER** is set.

Notification of Event Class B

Events Class B are defined in [Chapter 2.4.5.2.1](#).

In case an Event Class B is detected by the secondary side of the device, bit **SSTAT.FLTBS** is set for the duration of the failure condition. In case of transient events, it might not be possible to observe a change of the state of bits **SSTAT.FLTBS**

Bit **SSTAT.FLTBS** is mirrored automatically to bit **PSTAT2.FLTBP**.

If an Event Class B occurs that leads to a state transition (to OPM1), signal **NFLTB** is activated. In case an Event Class B occurs that does not lead to a state transition, **NFLTB** is not activated. However, the corresponding error bit in register **PER** or **SER** is set.

The level issued by the device on pins **NFLTA** and **NFLTB** is given by bits **PSTAT2.FLTA** and **PSTAT2.FLTB**. The levels read by the device at those pins is given by bits **PPIN.NFLTAL** and **PPIN.NFLTLB**.

Clearing Fault Notifications

[Table 12](#) describes how failure notifications are cleared:

Table 12 Failure Notification Clearing

	NFLTA / B signals	Primary Sticky Bits	Secondary Sticky Bits
PCTRL.CLRP set	De-assertion ¹⁾	Cleared	-
PCTRL.CLRS set ²⁾	-	-	Cleared
EN Invalid to Valid transition	De-assertion ³⁾	-	-

1) Depending of the configuration of bits **PCFG.CLFAM** and **PCFG.CLFBM**, the action may not be executed in case an error condition is being detected.

2) If the device is in OPM1, setting bit **SCTRL.CLRS** leads to a transition to OPM0

3) Only in OPM3 and OPM5. In other Operating Modes, no de-assertion is done.

Functional Description

A CLRP command (i.e. setting bit **PCTRL.CLRP**) clears all sticky bits on the primary side. A CLRS command (i.e. setting bit **PCTRL.CLRS**) clears all sticky bits on the secondary side.

Signals **NFLTA** and **NFLTBP** are de-asserted with an invalid to valid transition of signal **EN** (in OPM3 or OPM5 only). Besides, they can be de-asserted by a CLRP command, depending on the device' status.

In case bit **PCFG.CLFAM** is cleared, a CLRP command always deassert **NFLTA**. In case bit **PCFG.CLFAM** is set, a CLRP command does not deassert **NFLTA** in the following cases:

- **PSTAT2.FLTAP** is set
- OR
- **PSTAT2.ENVAL** is cleared

In case bit **PCFG.CLFBM** is cleared, a CLRP command always deassert **NFLTBP**. In case bit **PCFG.CLFBM** is set, a CLRP command does not deassert **NFLTBP** in the following cases:

- **PSTAT2.FLTBP** is set.
- OR
- bit **PSTAT.SRDY** is cleared

2.4.8 EN Signal Pin

The **EN** signal allows the logic on the primary side to have a direct control on the state of the device. A valid signal has to be provided on this pin. A valid to invalid transition of the signal on pin **EN** generates an Event Class A.

Pin **EN** should be driven actively by the external circuit. In case this pin is floating, an internal weak pull-down resistor ensures that the signal is low.

Note: It should be noted that even if the signal at pin EN is valid, the device can still be in disabled state. This may happen for example if another error is being detected

A valid **EN** signal is defined as a digital High level. When **EN** is at Low level, the signal is considered as not valid and the device is in Disabled State. In case of a High-to-Low transition, an Event Class A is generated.

An Invalid to Valid transition of signal **EN** deactivates signals **NFLTA** and **NFLTBP** (when the device is in OPM3 or OPM5 only).

The levels read by the device at pin **EN** is given by bits **PPIN.ENL**. The validity status of **EN** signal is given by bit **PSTAT2.ENVAL**.

Functional Description

2.4.9 Internal Supervision

The Internal Supervision functionality is summarized in [Table 13](#):

Table 13 System Supervision Overview

Parameter	Short Description
Function	Monitoring of the key internal functions of the chip.
Periodicity	Continuous.
Action in case of failure event	See below
Programmability	No.
In-System Testability	No.

The primary and secondary chips are equipped with internal verification mechanisms ensuring that the key functions of the device are operating correctly. The internal blocks which are supervised are listed below:

- Lifesign watchdog: mutual verification of the response of both chips (both primary and secondary).
- Oscillators (both primary and secondary, including open / short detection on signals [IREF1](#) and [IREF2](#)).
- Memory error (both primary and secondary).

2.4.9.1 Lifesign watchdog

The primary and the secondary chips monitor each other by the mean of a lifesign signal. The periodicity of the lifesign is typically t_{LS} . Each chip expects a lifesign from its counterpart within a given time window. In case a lifesign error is detected by a chip, a reset event is generated on both sides (lead to OPM0) as well as NFLTB pin is set. Duetto communication loss on both sides both bits [PER.CER1](#) and [SER.CER2](#) are set.

Note: Bits [PER.CER1](#) and [SER.CER2](#) indicate a loss of communication event. The current status of the internal communication is indicated by bit [PSTAT.SRDY](#).

2.4.9.2 Oscillator Monitoring

The main oscillators on the primary and on the secondary side are monitored continuously. Two distinct mechanisms are used for this purpose:

- Lifesign Watchdog allows to detect significant deviations from the nominal frequency (both primary and secondary, see above).
- Open / short detection on pin [IREF1](#).
- Open detection on pin [IREF2](#).

In case a failure is detected on pin [IREF1](#), the primary chip is kept in reset state for the duration of the failure and signal [NRST/RDY](#) is asserted, This leads to the detection of a lifesign error by the secondary chip, generating thus a reset event.

In case a failure is detected on pin [IREF2](#), an Emergency (regular) Turn-Off sequence is initiated. The secondary chip is kept in reset state for the duration of the failure. This leads to the detection of a lifesign error by the primary chip, generating thus a reset event.

Functional Description

2.4.9.3 Memory Supervision

The configuration parameters of the device, stored in the registers, are protected with a parity bit protection mechanism. Both primary and secondary chips are protected (refer to [Chapter 4](#)).

In case a failure is detected on the primary chip, it is kept in reset state, and both signal **NRST/RDY** and **NFLTb** are asserted. The secondary side initiates an Emergency (Regular) Turn-Off sequence.

In case a memory failure is detected by the secondary chip, an Emergency (Regular) Turn-Off sequence is initiated. The secondary chip is kept in reset state for the duration of the failure. This leads to the detection of a lifesign error by the primary chip.

2.4.9.4 Hardware Failure Behavior

The internal supervision functions can detect several failures which could lead to primary or secondary chip hold on (stay in reset). Failures which can be detected are mentioned in the table below. The supervision functions described in the chapters before will lead to this behavior.

Table 14 Failure Events Summary

Failure Event	Primary	Secondary	Notification (primary)	Notification (secondary)
OSC1 not starting at power-up	Stay in Reset	Idle	<ul style="list-style-type: none"> NRST/RDY Low. NFLTb activated. No SPI communication possible. 	<ul style="list-style-type: none"> Output Stage issues a PWM OFF command. OSD pin functionality operational.
IREF1 shorted to ground or open	Reset	Soft Reset	<ul style="list-style-type: none"> NRST/RDY Low. NFLTb activated. Frequency of OSC1 is out of range (may lead to SPI communication problems). 	<ul style="list-style-type: none"> Bit SER.CER2 set (in case of lifesign lost). Output Stage issues a PWM OFF command. OSD pin functionality operational.
Memory Error on Primary	Detected Hardware Fail causes PWM off	Soft Reset or regular off	<ul style="list-style-type: none"> NRST/RDY Low (stays forever). NFLTb activated. 	<ul style="list-style-type: none"> Bit SER.CER2 set (in case of lifesign lost). Output Stage issues a PWM OFF command. OSD pin functionality operational.
OSC2 not starting at power-up	Normal Operation	Stay in Reset	<ul style="list-style-type: none"> NFLTb activated, bit PER.CER1 is set. Bit PSTAT.SRDY stay 0. 	<ul style="list-style-type: none"> Output Stage issues a PWM OFF command. OSD pin functionality operational.
OSC2 misfunction during operation	Detected Lifesign loss causes PWM off	Soft Reset or regular off	<ul style="list-style-type: none"> NFLTb activated, bit PER.CER1 is set Bit PSTAT.SRDY cleared for the duration of the failure. 	<ul style="list-style-type: none"> Output Stage issues a PWM OFF command. OSD pin functionality operational.

Functional Description

Table 14 Failure Events Summary

Failure Event	Primary	Secondary	Notification (primary)	Notification (secondary)
IREF2 open	Normal Operation	Stay in Reset	<ul style="list-style-type: none"> • NFLT activated, bit PER.CER1 is set. • Bit PSTAT.SRDY cleared. 	<ul style="list-style-type: none"> • Signal NUV2 at Low level (if $V_{CC2} < V_{UVLO2}$). • Output Stage issues a PWM OFF command. • OSD pin functionality operational for: $V_{CC2} > V_{RST2}$.
VREG shorted to ground	Normal Operation	Stay in Reset	<ul style="list-style-type: none"> • NFLT activated, bit PER.CER1 is set. • Bit PSTAT.SRDY cleared. 	<ul style="list-style-type: none"> • Signal NUV2 at Low level (if $V_{CC2} < V_{UVLO2}$). • Output Stage clamped to V_{EE2}. • OSD pin not functional.
Memory Error on Secondary	Normal Operation	Detected hardware fail causes permanent reset	<ul style="list-style-type: none"> • NFLT activated, bit PER.CER1 is set. • Bit PSTAT.SRDY cleared. 	<ul style="list-style-type: none"> • Output Stage issues a PWM OFF command. • OSD pin functionality operational.
Noise on IREF1	Reset	Soft Reset	<ul style="list-style-type: none"> • NRST/RDY Low. • NFLT activated. • Frequency of OSC1 is out of range (may lead to SPI communication problems). 	<ul style="list-style-type: none"> • Bit SER.CER2 set (in case of lifesign lost). • Output Stage issues a PWM OFF command. • OSD pin functionality operational.
Noise on IREF2/VREG	Normal Operation	Soft Reset	<ul style="list-style-type: none"> • NFLT activated, bit PER.CER1 is set. • Bit PSTAT.SRDY cleared. 	<ul style="list-style-type: none"> • Signal NUV2 at Low level (if $V_{CC2} < V_{UVLO2}$). • Output Stage issues a PWM OFF command. • OSD pin functionality operational for: $V_{CC2} > V_{RST2}$.

2.4.10 Reset Events

A reset event sets the device and its internal logic in the default configuration. All user-defined settings are overwritten with the default values. The list of reset events and their effect is summarized in [Table 15](#).

Note: As already shown in [Figure 11](#) all reset events will result in an operation mode change. The entered mode will be **OPM0**.

Functional Description

Table 15 Reset Events Summary

Reset Event	Primary	Secondary	Notification (primary)	Notification (secondary)
NRST/RDY Input signal active (driven externally)	Reset	Soft Reset	<ul style="list-style-type: none"> NRST/RDY Low (during event). Bit PER.RSTE1 and PER.RST1 set. Bit PER.CER1 is not set. NFLT B activated at the end of the reset event. 	<ul style="list-style-type: none"> Bit SER.CER2 set (in case of lifesign lost). Output Stage issues a PWM OFF command. OSD pin functionality operational.
UVLO1 Event	Reset	Soft Reset	<ul style="list-style-type: none"> NRST/RDY Low (driven by device during event). Bit PER.RST1 set (once V_{CC1} valid again). Bit PER.CER1 is not set. NFLT B activated at the end of the reset event. 	<ul style="list-style-type: none"> Bit SER.CER2 set (in case of lifesign lost). Output Stage issues a PWM OFF command. OSD pin functionality operational.
V _{CC2} Reset Event (communication loss due to voltage breakdown on V _{CC2} ; V _{CC2} < V _{RST2})	-	Hard Reset	<ul style="list-style-type: none"> NFLT B activated, bit PER.CER1 is set. Bit PSTAT.SRDY cleared for the duration of the failure. 	<ul style="list-style-type: none"> Signal NUUV2 at Low level (if V_{CC2} < V_{UVLO2}). Bit SER.RST2 (once V_{CC2} valid again). Output Stage issues a PWM OFF command. OSD pin functionality operational for: V_{CC2} > V_{RST2}.

Note: Reset's can also happen due to failures, therefore please check the [Table 14 "Failure Events Summary"](#) on Page 48 as well.

Note: If undervoltage event occur on VCC2, OSD will work until voltage is too less, than automatically passive clamping will take over. When voltage rising again it behave other way around, but never both functions operate in parallel.

All reset events set the device in Mode OPM0. In a soft reset, the logic works further, but the registers use the default values.

In case of a reset condition on the primary side, the behavior of the pin of the device is defined in [Table 16](#).

Table 16 Pin behavior (primary side) in case of reset condition

Pin	Output Level	Comments
SDO	Low	
NFLT B	Low	
NFLT A	High	
NRST/RDY	Low (GND1)	

Functional Description

In case of a hard reset condition on the secondary side, the behavior of the pin of the device is defined in [Table 17](#).

Table 17 Pin behavior (secondary side) in case of reset condition

Pin	Output Level	Comments
TON	Low (V_{EE2})	Passive Clamping
TOFF	Low (V_{EE2})	Passive Clamping
DESAT	Low (GND2)	Clamped.
GATE	Low (V_{EE2})	Passive Clamping
DACL	High (V_{REG2})	Active clamping disabled by default.
NUV2	Low (GND2)	
AMCLP	High (V_{REG2})	Miller Clamping enabled by default.
VREG	V_{REG2} typ.	if $V_{CC2} > 6V$ typ. ¹⁾

1) For more information see [Table 55](#).

2.4.11 Operation in Configuration Mode

This section describes the mechanisms to configure the device.

2.4.11.1 Static Configuration Parameters

Static parameters can be configured when the device is in Mode OPM2 by writing the appropriate register.

Once Mode OPM2 is left with the SPI Command EXIT_CMODE, the configuration parameters are frozen on both primary and secondary chips. This means in particular that write accesses to the corresponding registers are invalidated. This prevents static configurations to be modified during runtime. Besides, the configuration parameters on the primary and secondary side are protected with a memory protection mechanism. In case the values are not consistent, a Reset Event and / or an Event Class B is generated.

2.4.11.1.1 Configuration of the SPI Parity Check

The SPI interface supports by default an odd parity check. The Parity Check mechanism (active at the reception of an SPI word) can be disabled by setting bit [PCFG.PAREN](#) to 0_B. Setting bit [PAREN](#) to 1_B enables the Parity Check.

Parity Bit Generation for the transmitter can not be disabled.

2.4.11.1.2 Configuration of the V_{BE} Compensation

The V_{BE} compensation of signal [TON](#) and [TOFF](#) can be activated or deactivated by writing bit [SCFG.VBEC](#). See [Chapter 2.4.6](#) for more details.

Functional Description

2.4.11.1.3 Clamping of DESAT pin

By setting bit **SCFG.DSTCEN**, the DESAT signal is clamped to V_{GND2} while the output stage of the device issues a PWM OFF command and during blanking time periods (including safe turn-off sequences). By clearing bit **SCFG.DSTCEN**, the DESAT clamping is only activated during blanking time periods (including safe turn-off sequences).

2.4.11.1.4 Activation of the Pulse Suppressor

The pulse suppressor function associated with the TTOFF function can be activated by setting bit **SCFG.PSEN**. When activated, **SRTTOF.RTVAL** shall be programmed with a minimum value (see [Page 110](#)).

2.4.11.1.5 Configuration of the Verification Mode Time Out Duration

The duration of the time out in verification mode is selectable via bit **SCFG.TOSEN**.

2.4.11.1.6 Configuration of the TTOFF Delays

The TTOFF delays for Regular and Safe Turn-Off sequences can be programmed separately by writing registers **SRTTOF** or **SSTTOF**. The delay for Regular Turn-Off can also be configured using the Timing Calibration Feature.

Programming 0_H as a delay value disables the TTOFF for the concerned Turn-Off Sequence. Hard turn-off are performed instead. In case the TTOFF function is wished, a minimum value for the delay has to be programmed (see [Page 110](#) and [Page 112](#)).

When safe two level turn-off is used (non zero delay) in normal operating mode (OPM4), the programmed safe turn-off delay value shall be higher than the programmed regular two level turn off delay.

2.4.11.1.7 Configuration of the TTOFF Plateau Level

The plateau level for safe two level turn off sequences can be programmed with bit fields **SRTTOF.GPR** and **SSTTOF.GPS**. The plateau level value for safe turn-off sequences shall be lower than the one selected for regular turn-off sequences.

2.4.11.1.8 Configuration of the DESAT Blanking Time

The blanking time for the DESAT protection can be configured by writing bit field **SDESAT0.DSATBT** and / or **SDESAT1.DSATBT**. In case this function is used, a minimum value for the delay has to be programmed (see [Page 108](#)).

Note: The programmed OCP blanking time shall be smaller than the programmed DESAT blanking time.

2.4.11.1.9 Configuration of the OCP Blanking Time

The blanking time for the OCP protection can be configured by writing bit field **SOCP.OCPBT**. Programming 0_H deactivates the blanking time feature which leads to an immediate reaction on OCP. The programmed blanking time shall not exceed a maximum value (see [Page 109](#)).

Note: The programmed OCP blanking time shall be smaller than the programmed DESAT blanking time.

2.4.11.1.10 Configuration of **DACLP** Activation Time

The **DACLP** activation time after hard commutation can be programmed by writing bit field **SACLT.AT**. In case value 0_H is programmed, the device delivers at **DACLP** a constant High level. In case an activation time is required, a minimum value for the delay has to be programmed (see [Page 114](#)). In case value FF_H is programmed, the device delivers a constant Low level at **DACLP**. If the time programmed in **SACLT.AT** is longer than the pause to the next pulse on TON the signal will not be canceled, but triggered again that the timer is starting again.

2.4.11.2 Delay Calibration

In order to compensate for timing errors due to part-to-part variations, a dedicated Timing Calibration Feature (TCF) has been implemented. The TCF works in such a way that the PWM input signal is used to start and stop a counter clocked by the Start-Stop Oscillator of the Output Stage. As a result, the following delays and timing can be configured that way:

- TTOFF delay for Regular Turn-Off.

The TCF allows to compensate for part to part variations of the frequency of the Start-Stop oscillator. This results in better accuracy for application critical timing. Device specific variations, e.g. temperature related, are not compensated though.

The TCF can be activated or deactivated in Configuration Mode by writing bit field **SSCR.VFS2**. The device shall then be set in OPM6 and the PWM signal applied. Details about the TCF operation are given in [Chapter 3.5.9](#).

3 Protection and Diagnostics

This section can describes the safety relevant functions implemented in the 1EDI2004AS.

3.1 Supervision Overview

The 1EDI2004AS driver provides extended supervision functions, in order to achieve ASIL requirements on system level. [Table 18](#) gives an overview of the implemented functions.

Table 18 Safety Related Functions

Protection Feature	Description	Category	Comments
DESAT	Monitoring of the collector-emitter voltage of the IGBT in ON state.	A	See Chapter 3.2.1
OCP	Monitoring of the current on the IGBT's auxiliary emitter path.	A	See Chapter 3.2.2
External Enable	Fast deactivation via an external Enable signal on the primary.	A	See Chapter 3.2.3
Power Supply Monitoring	Under Voltage Lock-Out function on V_{CC1} , V_{CC2} and V_{EE2} ; Over Voltage Lock-Out on V_{EE2} and V_{CC2} .	B	See Chapter 3.3.1
STP	Shoot Through Protection.	C	See Chapter 3.4.1
Gate Monitoring	Monitoring of the GATE voltage	C	See Chapter 3.4.2
SPI Error Detection	SPI Error Detection.	C	See Chapter 3.4.3
Active Short Circuit Support	V_{CC2} not valid error notification	C	See Chapter 3.4.4
DESAT Time Out	Desat Blanking Time Selection timeout.	C	See Chapter 3.2.1
OVLO2 Mode Timeout	OVLO2 Mode timeout.	C	See Chapter 3.3.1
WTO	Weak Turn-On Functionality	D	See Chapter 3.5.2
DESAT Supervision	Supervision of the DESAT function during application life time.	D	See Chapter 3.5.3 , Chapter 3.5.4 and Chapter 3.5.5
OCP Supervision	Supervision of the OCP function during application life time.	C & D	See Chapter 3.5.6 , Chapter 3.5.7 and Chapter 3.2.2
Power Supply Monitoring Supervision	Supervision of the OVLO / UVLO function during application life time.	D	See Chapter 3.5.8
Internal Clock Supervision	Plausibility check of the frequency of the internal oscillator.	D	See Chapter 3.5.9
TTOFF	Two Level Turn-Off	E	See Chapter 2.4.6
SPI Communication	SPI Communication (using register PRW).	E	See Chapter 4.1
Overvoltage robustness	Robustness against transient overvoltage on power supply.	E	See Chapter 5.2

From the conceptual point of view, the protection functions can be clustered into five main categories.

Protection and Diagnostics

- Category A corresponds to the functions where the device “decides on its own”, after the detection of an Event Class A, to change the state of the output stage and to disable itself. A dedicated action from the user is needed to reactivate the device (fast reactivation).
- Category B corresponds to the functions where the device “decides on its own”, after the detection of an Event Class B, to change the state of the output stage and to disable itself. A complete reinitialization from the user is needed to reactivate the device (slow reactivation).
- Category C corresponds to the functions that only issue a notification in case an error is detected.
- Category D are intrusive supervision functions, aimed at being started when the application is not running.
- Category E corresponds to implemented functions or capabilities supported by the device whose use can enhance the overall safety coverage of the application.

3.2 Protection Functions: Category A

3.2.1 Desaturation Protection

The integrated desaturation (DESAT) functionality is summarized in [Table 19](#):

Table 19 DESAT Protection Overview

Parameter	Short Description
Function	Monitoring of the V_{CE} voltage of the IGBT.
Periodicity	Continuous while device issues a PWM ON command.
Action in case of failure event	<ol style="list-style-type: none"> 1. Emergency (Safe) Turn-off Sequence. 2. Error Flag SER.DESATER is set. 3. Assertion of signal NFLTA.
Programmability	Yes (blanking time).
In-System Testability	Yes (see also Chapter 3.5.3 and Chapter 3.5.4).

The DESAT function aims at protecting the IGBT in case of short circuit. The voltage drop V_{CE} over the IGBT is monitored via the [DESAT](#) pin while the device issues a PWM ON command. The voltage at pin [DESAT](#) is externally filtered by an external RC filter, and decoupled by an external diode (see [Figure 17](#)). The DESAT voltage is compared to an internal reference voltage. The result of this comparison is available by reading bit [SSTAT2.DSATC](#).

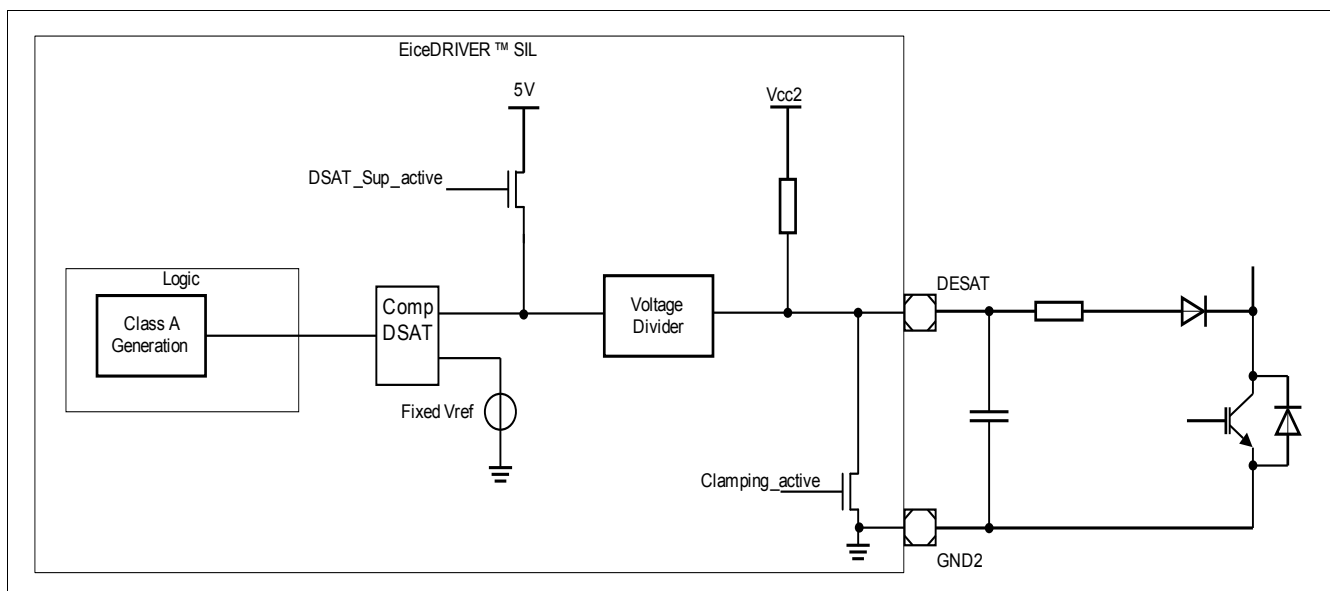

Figure 17 DESAT Function: Diagram of Principle

At the beginning of a turn-on sequence, the voltage at pin [DESAT](#) is forced to Low level for the duration the blanking time defined by register [SDESAT0](#) (or [SDESAT1](#), see below). Once the blanking time has elapsed, the voltage at pin [DESAT](#) is released and is compared to an internal reference voltage. Depending on the value of the decoupling capacitance, an additional “analog” blanking time will be added corresponding to the charging of the capacitance through the internal pull-up resistance ([Figure 18](#)).

Protection and Diagnostics

In case the measured voltage is higher than the internal threshold, an Emergency (Safe) Turn-Off sequence is initiated, bit **SER.DESATER** is set and a fault notification is issued on pin **NFLTA** (in case of an OPM transition the state machine - see [Chapter 2.4.7](#)).

The DESAT function is not active while the output stage is in PWM OFF state.

The blanking time needs to be chosen carefully, since the DESAT protection may be *de facto* inhibited if the PWM ON-time is too short compared to the chosen blanking time.

At turn-off, the DESAT signal is pulled down for the duration of the TTOFF plateau time, and extended by the blanking time (only if less than 0x40 is configured) once the hard turn off sequence is initiated.

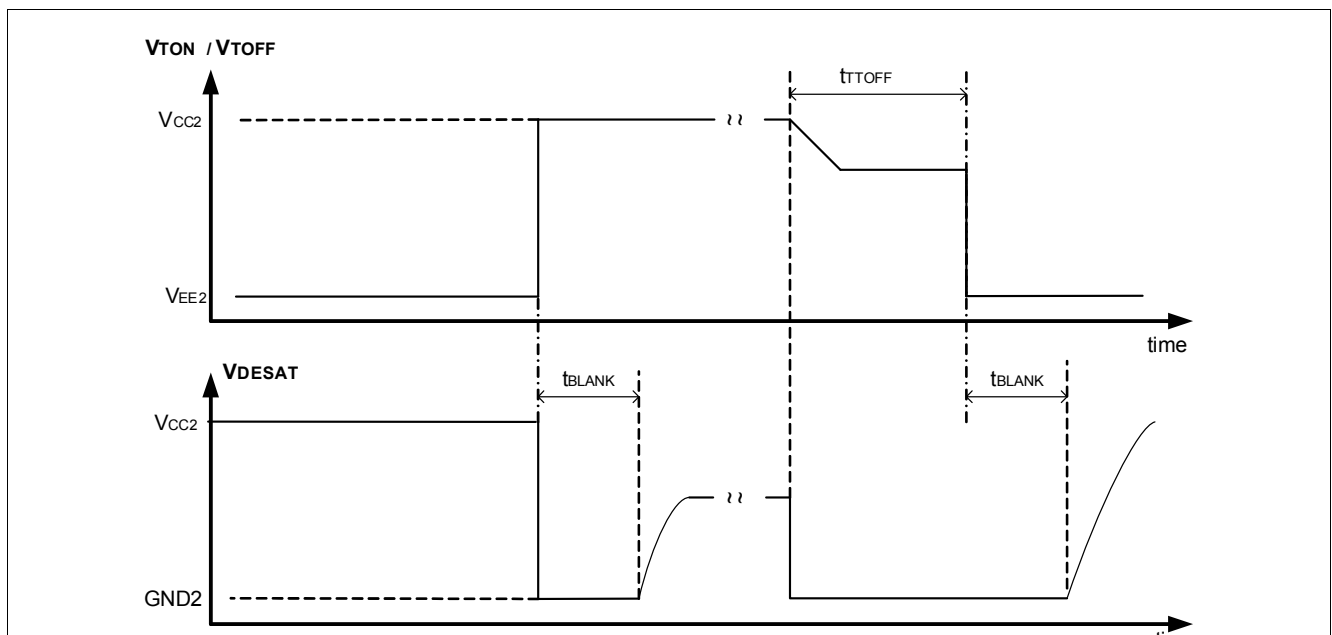

Figure 18 DESAT Operation

Note: In case the **DESAT** pin is open, the pull-up resistance ensures that a DESAT event is generated at the next PWM turn-on command.

DESAT Clamping during turn-off

The internal pull-up resistance may lead to the unwanted charging of the DC-link capacitance via the DESAT pin. In order to overcome this, the DESAT function needs to be activated by setting bit **SCFG.DSTCEN**. When this bit is set, pin **DESAT** is internally clamped to GND2 when a PWM off command is issued by the device.

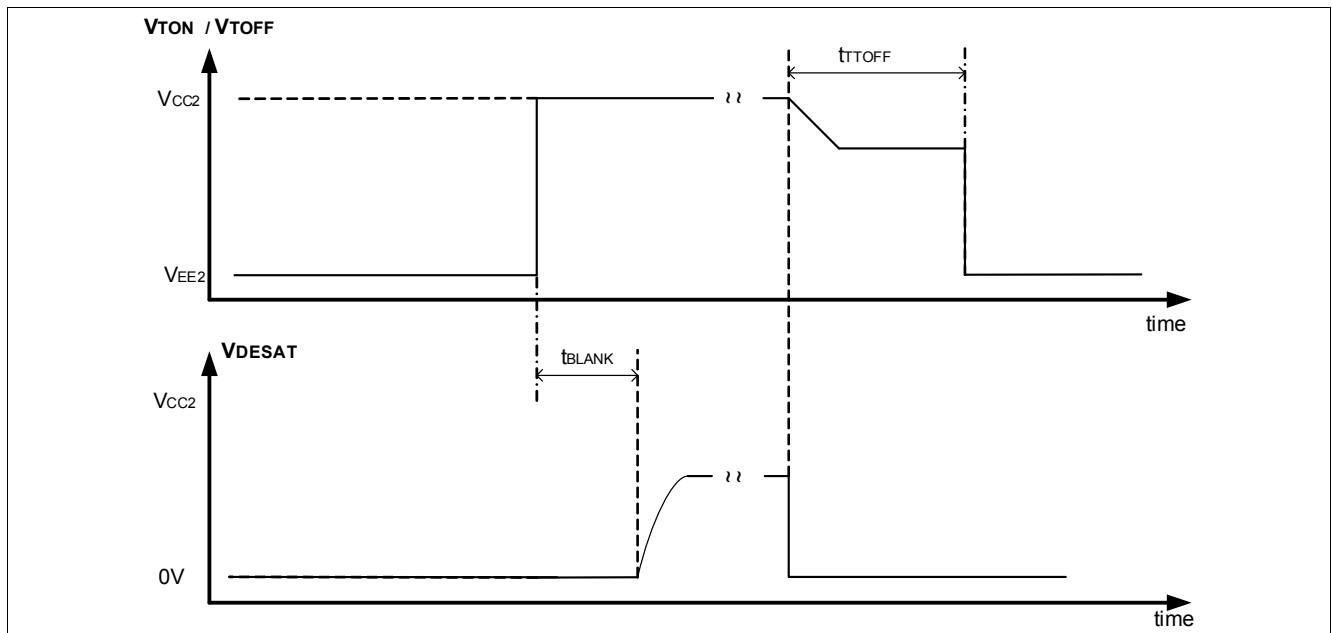

Figure 19 DESAT Operation with DESAT clamping enabled

Note: AMCLD delay is not in use for DESAT or OCP events.

DESAT blanking time selection

The blanking time of the DESAT function can be switched in run time between two values, defined by registers **SDESAT0** and **SDESAT1**. The active register is shown by secondary bit **SCTRL.DTSELS**, and by its mirrored primary bit **PSTAT.DTSELP**.

The selection of the active register is done by writing bits **PCTRL.DTSP** and **PCTRL.DTRP**. Those bits are mirrored to respectively **SCTRL.DTSS** and **SCTRL.DTRS**.

SCTRL.DTSELS is set when both bits **SCTRL.DTSS** and **SCTRL.DTRS** are set.

SCTRL.DTSELS is cleared when bit **SCTRL.DTSS** is cleared OR when a DESAT watchdog timeout occurs.

When a transition from 0_B to 1_B occurs at bit **SCTRL.DTSELS**, an internal timer is reset and starts incrementing. The timer counts as long as bit **SCTRL.DTSELS** remains set. The timer is reset at the transition from 0_B to 1_B of bit **SCTRL.DTRS**. In case the timer is not refreshed before overflowing leading to timeout, bit **SCTRL.DTSELS** is cleared automatically (i.e. **SDESAT0** is active) and error bit **SER.DBTO** is set.

3.2.2 Overcurrent Protection

The integrated Over Current Protection (OCP) functionality is summarized in **Table 20**:

Table 20 OCP Function Overview

Parameter	Short Description
Function	Monitoring of the voltage drop over an external resistor located on the auxiliary emitter path of the IGBT.
Periodicity	Continuous while device issues a PWM ON command.
Action in case of failure event	<ol style="list-style-type: none"> Emergency (Safe) Turn-off Sequence. Error Flag SER.OCPER is set. Assertion of signal NFLTA.

Protection and Diagnostics

Table 20 OCP Function Overview (cont'd)

Parameter	Short Description
Programmability	No
In-System Testability	Yes (see Chapter 3.5.6).

The integrated Over Current Protection (OCP) function aims at protecting the IGBT in case of overcurrent and short-circuit conditions. The voltage drop over a sense resistor located on the auxiliary emitter path of the IGBT is monitored via the **OCP** while the device issues a PWM ON command. The voltage at pin **OCP** is externally filtered by an (optional) RC filter and compared (using internal voltage comparator) to the internal reference threshold V_{OCPD1} (see [Figure 20](#)). The result of the comparison is available by reading bit **SSTAT2.OCP1**.

Note: Bit **SSTAT2.OCP1** blanked by the selected blanking time.

At the beginning of a turn-on sequence, the internal evaluation of the voltage at pin **OCP** is inhibited for the duration the blanking time defined by register **SOCP**. Once the blanking time has elapsed, the voltage at pin **OCP** is compared to an internal reference voltage.

In case the measured voltage at pin **OCP** is higher than the internal threshold V_{OCPD1} , an Emergency (Safe) Turn-off sequence is initiated, bit **SER.OCPER** is set and a fault notification is issued on pin **NFLTA** (in case of an OPM transition the state machine - see [Chapter 2.4.7](#)). The OCP function is not active while the output stage is in PWM OFF state.

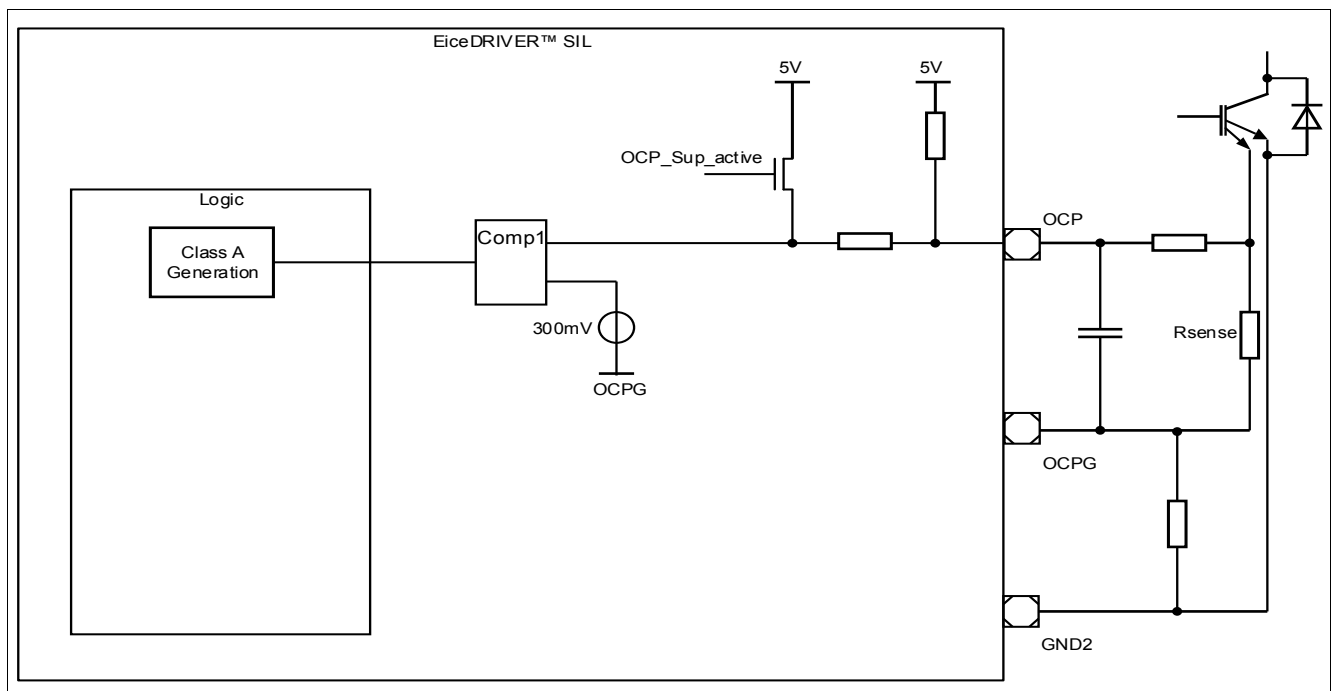

Figure 20 OCP Function: Principle of Operation

Notes

1. If $TLTOFF$ times are used, these times should be taken into consideration for the blanking time to reach valid voltage levels.
2. $AMCLD$ delay is not in use for safe-off triggered by $DESAT$ or OCP events.
3. In case the **OCP** pin is open, the pull-up resistance ensures that an OCP event is generated.
4. Both $DESAT$ and OCP protection mechanisms can be used simultaneously.

Protection and Diagnostics

3.2.3 External Enable

The External Enable functionality is summarized in [Table 21](#):

Table 21 External Enable Function Overview

Parameter	Short Description
Function	External Enable.
Periodicity	Invalid signal on EN pin.
Action in case of failure event	<ol style="list-style-type: none"> 1. Emergency (Regular) Turn-off Sequence. 2. Error Flag PER.ENER is set. 3. Assertion of signal NFLTA.
Programmability	No.
In-System Testability	Yes.

The functionality of the signal at pin **EN** is given in [Chapter 2.4.8](#). In case of a Valid-to-Invalid signal transition, an error is detected. In this case, an Emergency (Regular) turn-off sequence is initiated, bit **PER.ENER** is set and a fault notification is issued on pin **NFLTA** (in case of an OPM transition the state machine - see [Chapter 2.4.7](#)). The current validity state of the signal at pin **EN** can be read on bit **PSTAT2.ENVAL**.

This function can be tested by generating an invalid signal on pin **EN** and verifying that the actions done by the device correspond to the expected behavior.

3.3 Protection Functions: Category B

3.3.1 Power Supply Voltage Monitoring

The Power Supply Voltage Monitoring functionality is summarized in [Table 22](#):

Table 22 Power Supply Voltage Monitoring Overview

Parameter	Short Description
Function	Monitoring of V_{CC1} , V_{CC2} , V_{EE2} .
Periodicity	Continuous.
Action in case of failure event	<ol style="list-style-type: none"> Emergency (Regular) Turn-off Sequence. Error Flag PER.RST1 (UVLO1) or SER.UVLO2ER or OVLO2ER or UVLO3ER or OVLO3ER is set. Assertion of signal NRST/RDY (UVLO1 only) or NFLTb.
Programmability	Yes (OVLO2 and OVLO3).
In-System Testability	Yes (see Chapter 3.5.8).

In order to ensure a correct switching of the IGBT, the device supports an undervoltage lockout (UVLO) function for V_{CC1} , V_{CC2} , V_{EE2} , and an overvoltage lockout (OVLO) function for V_{CC2} and V_{EE2} ([Figure 21](#)).

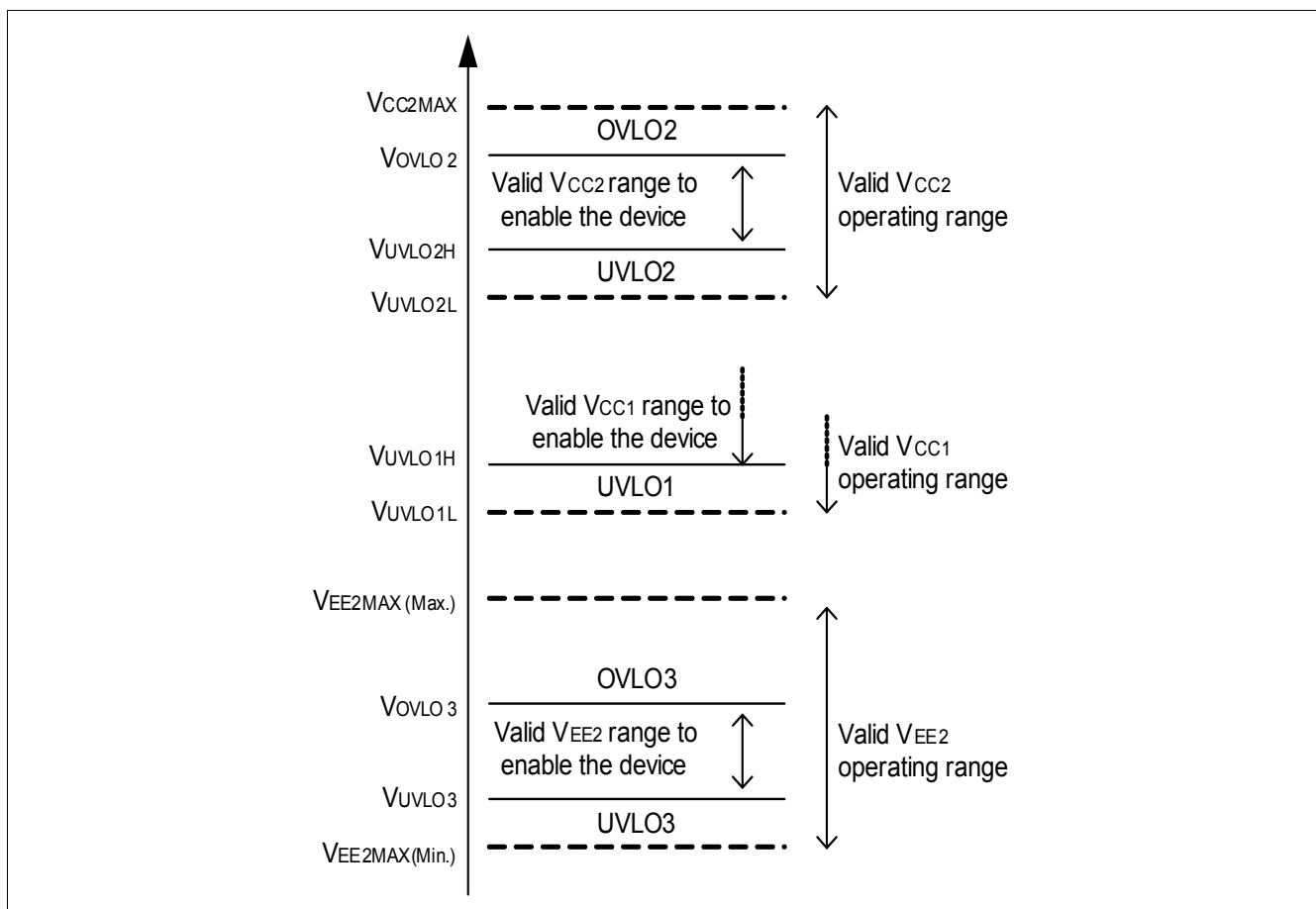

Figure 21 Power Supply Supervision Function

Protection and Diagnostics

The V_{CC1} voltage is compared (using an internal voltage comparator) to an internal reference threshold. If the power supply voltage V_{CC1} of the primary chip drops below V_{UVLO1L} , an error is detected. In this case, an emergency (Regular) turn-off sequence is initiated and signal **NRST/RDY** goes low. In case V_{CC1} reaches afterwards a level higher than V_{UVLO1H} , then the error condition is removed and signal **NRST/RDY** is deasserted. Besides, bit **PER.RST1** is set.

The V_{CC2} voltage is compared (using an internal voltage comparator) to an internal reference threshold. If the power supply voltage V_{CC2} of the secondary chip drops below V_{UVLO2L} , an error is detected. In this case, an emergency (Regular) turn-off sequence is initiated, bit **SER.UVLO2ER** is set and signal **NFLTB** is activated (in case of an OPM transition the state machine - see [Chapter 2.4.7](#)). In case V_{CC2} reaches afterwards a level higher than V_{UVLO2H} , then the error condition is removed and the device can be reenabled.

The V_{CC2} voltage is compared (using an internal voltage comparator) to an internal reference threshold. If the power supply voltage V_{CC2} of the secondary chip goes above V_{OVLO2H} , an error is detected. In this case, an emergency (Regular) turn-off sequence is initiated, bit **SER.OVLO2ER** is set and signal **NFLTB** is activated (in case of an OPM transition the state machine - see [Chapter 2.4.7](#)). In case V_{CC2} reaches afterwards a level below V_{OVLO2L} , then the error condition is removed and the device can be reenabled.

The OVLO2 failure reaction can be switched in run time, defined by register **PCTRL2**. The active status is shown by secondary bit **SCTRL.O2MSELS**. Where an 0_B select a generation of class B event and a 1_B generation of class C event.

The selection of the mode is done by writing bit **PCTRL2.O2MSP**. The watchdog timer is reset due to a transition from 0_B to 1_B of bit **PCTRL2.O2MRP**. Those bits are mirrored to respectively **SCTRL.O2MSS** and **SCTRL.O2MRS**.

SCTRL.O2MSELS is set when both bits **SCTRL.O2MSS** and **SCTRL.O2MRS** are set.

SCTRL.O2MSELS is cleared when bit **SCTRL.O2MSS** is cleared OR when a OVLO2 watchdog timeout occurs.

When a transition from 0_B to 1_B occurs at bit **SCTRL.O2MSELS**, an internal timer is reset and starts incrementing. The timer counts as long as bit **SCTRL.O2MSELS** remains set. In case the timer is not refreshed before overflowing leading to timeout, bit **SCTRL.O2MSELS** is cleared automatically and error bit **SER.O2MTO** is set.

The V_{EE2} voltage is compared (using an internal voltage comparator) to an internal reference threshold. If the power supply voltage V_{EE2} of the secondary chip drops below V_{UVLO3L} an error is detected. In this case, an emergency (Regular) turn-off sequence is initiated, bit **SER.UVLO3ER** is set and signal **NFLTB** is activated (in case of an OPM transition the state machine - see [Chapter 2.4.7](#)). In case V_{EE2} reaches afterwards a level higher than V_{UVLO3H} , then the error condition is removed and the device can be reenabled.

The V_{EE2} voltage is compared (using an internal voltage comparator) to an internal reference threshold. If the power supply voltage V_{EE2} of the secondary chip goes above V_{OVLO3H} , an error is detected. In this case, if bit **SCFG.OVLO3D** is set to 0_B a (Regular) turn-off sequence is initiated, bit **SER.OVLO3ER** is set and signal **NFLTB** is activated (in case of an OPM transition the state machine - see [Chapter 2.4.7](#)). In case V_{EE2} reaches afterwards a level below V_{OVLO3L} , then the error condition is removed and the device can be reenabled. **NFLTB**

The current status of the error detection of OVLO2, UVLO3 and OVLO3 mechanism is available by reading bit **SSTAT2.UVLO2M**, **OVLO2M**, **UVLO3M** or **OVLO3M** respectively.

For a proper handling of different V_{EE2} voltages (i.e. 0V) the bit **SCFG.OVLO3D** can be set to 1_B (default) for disable the OVLO3 function.

Note: In case V_{CC2} goes below the voltage V_{RST2} , the secondary chip is kept in reset state.

3.4 Protection Functions: Category C

3.4.1 Shoot Through Protection function

The Shoot Through Protection (STP) functionality is summarized in [Table 23](#):

Table 23 STP Overview

Parameter	Short Description
Function	Prevents both High-Side and Low-Side Switches to be activated simultaneously.
Periodicity	Continuous.
Action in case of failure event	1. The signal at pin INP is inhibited. 2. Error Flag PER.STPER is set.
Programmability	No.
In-System Testability	Yes.

With the implemented STP function, a low-side (resp. high-side) device is able to monitor the status of its high-side (resp. low-side) counterpart. The input pin **INSTP** provides an input for the PWM signal of the driver's counterpart ([Figure 22](#)).

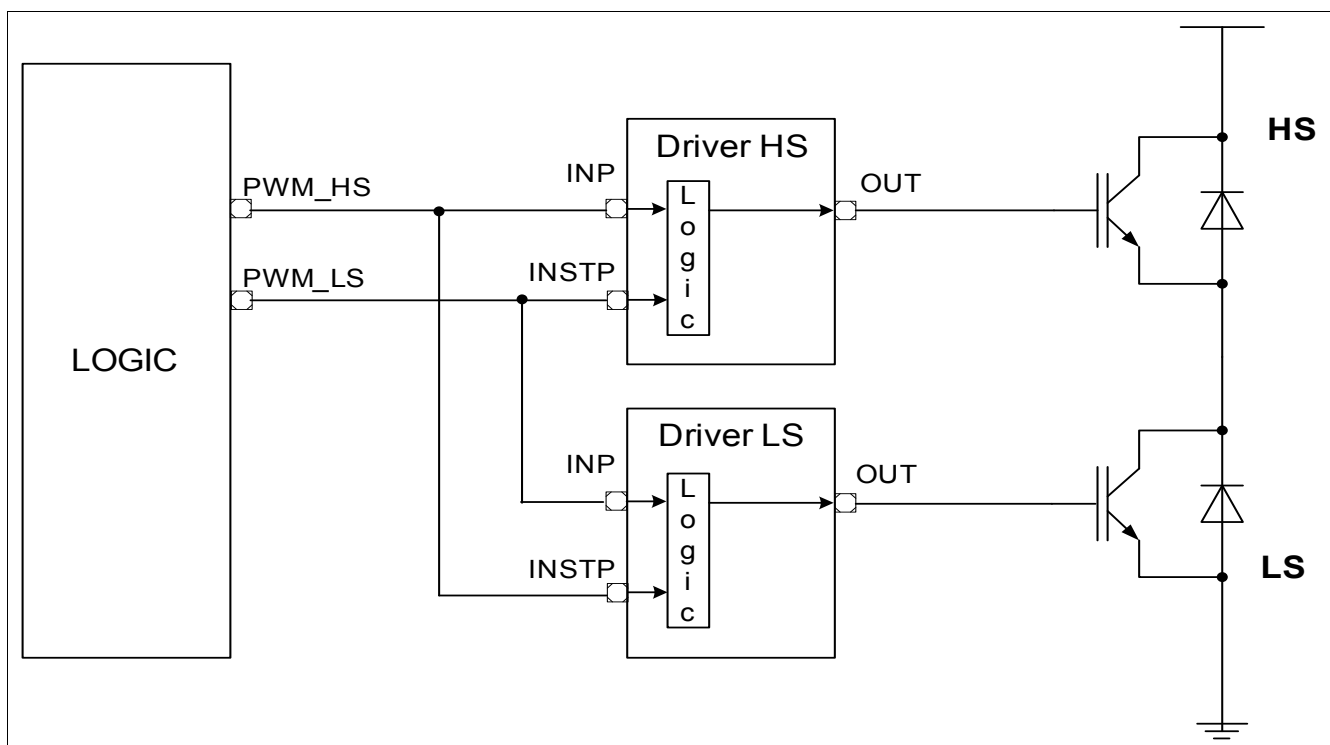

Figure 22 Shoot Through Protection: Principle of Operation

In case one of the driver is in ON state, the driver's counterpart PWM input is inhibited, preventing it to turn-on (See [Chapter 2.4.3](#)). A minimum dead time is defined by hardware. Conceptually, the STP aims at providing an additional “line of defense” for the system in case erroneous PWM commands are issued by the primary logic. In normal operation, dead time management shall be performed at the microcontroller level.

Protection and Diagnostics

In case a PWM ON command is received on pin **INP** during the inhibition time, a failure event is detected. In this case, the high level at pin **INP** is ignored and bit **PER.STPER** is set.

Note: Internal filter ensures that **STPER** is not set for glitches smaller than approximately 50ns.

The STP can be tested by applying non valid **INSTP** and **INP** and by checking bit **PSTAT2.STP**.

The STP can not be disabled. However, setting pin **INSTP** to V_{GND1} deactivates de facto the function, but it should be mentioned that during power up a signal on **INP** will always set bit **PER.STPER** and prevent a turn on.

3.4.2 Gate Monitoring

The Gate Monitoring functionality is summarized in [Table 24](#):

Table 24 Gate Monitoring Overview

Parameter	Short Description
Function	Monitors the voltage at pin GATE .
Action in case of failure event	N.a.
Programmability	No
In-System Testability	Yes

There are two comparators available to check the current level of the voltage at the pin **GATE**. Therefore are both levels are given in [Table 56](#) as V_{GATE1L} from V_{CC2} to V_{EE2} , V_{GATE1H} from V_{EE2} to V_{CC2} (**SSTAT2.GC1**) and V_{GATE2L} from V_{CC2} to V_{EE2} , V_{GATE2H} from V_{EE2} to V_{CC2} . (**SSTAT2.GC2**). If the voltage at pin **GATE** is below the level **SSTAT2.GC1** and **SSTAT2.GC2** will be set to 0_B above the level the bits are set to 1_B .

There is no triggering necessary.

The Gate Monitoring can be tested on system level by (for example) pulling the IGBT gate signal high while the device issues a PWM Low command. This can be done for example in combination with the ASC function of Infineon's 1EBN100XAE "EiceDRIVER™ Boost" booster stage. It can then be verified that the reaction of the device corresponds to the expected behavior.

3.4.3 SPI Error Detection

The SPI Error Detection mechanisms are summarized in [Table 25](#):

Table 25 SPI Error Detection Overview

Parameter	Short Description
Function	Non valid SPI command detection and notification.
Periodicity	Continuous.
Action in case of failure event	Flag PER.SPIER is set.
Programmability	Yes (parity can be disabled).
In-System Testability	Yes.

For more details, see [Chapter 2.4.4.4](#).

Protection and Diagnostics

The SPI Error Detection Mechanism can be tested by inserting on purpose a dedicated error and by verifying that the device’s reaction is conform to specification.

3.4.4 Active Short Circuit Support

The Active Short Circuit Support Function is summarized in [Table 26](#):

Table 26 Active Short Circuit Support Overview

Parameter	Short Description
Function	Notification in case V_{CC2} is below the UVLO2 threshold or internal digital supply not valid.
Periodicity	Continuous.
Action in case of failure event	Signal NUV2 activated.
Programmability	No.
In-System Testability	Yes.

This feature is aimed at being used in combination with a booster device supporting a direct turn-on input (pin ASC, see [Figure 23](#)). Any time the voltage V_{CC2} goes below threshold V_{UVLO2L} , or the internal digital voltage supply is not valid, the open drain pin **NUV2** drives a low level for the duration of the event.

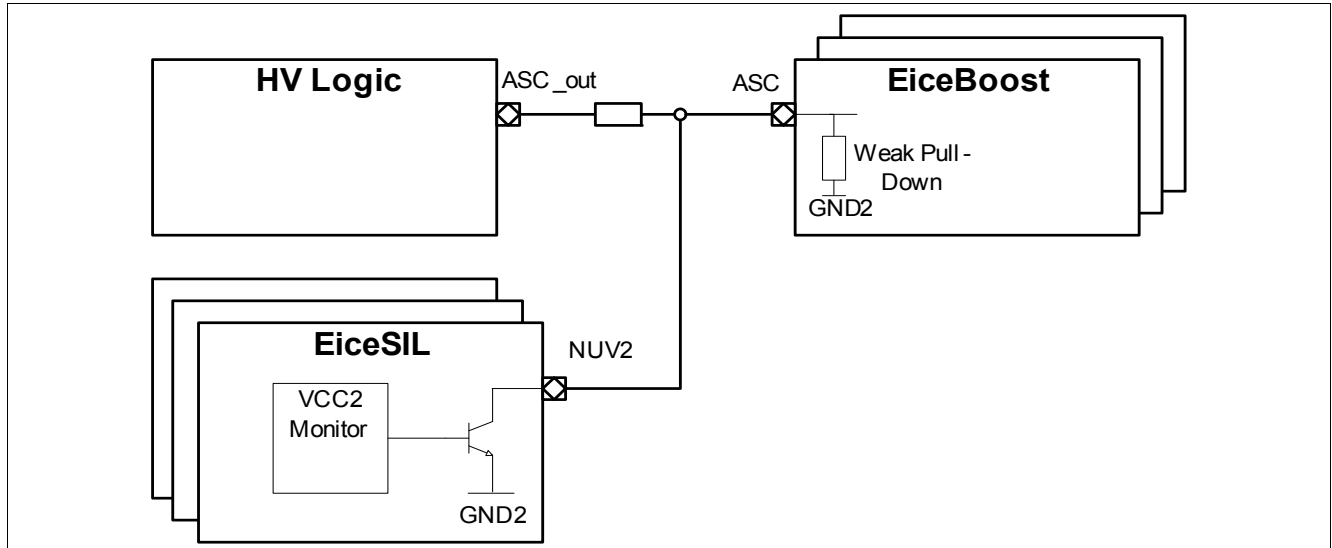

Figure 23 ASC Strategy Support

The **NUV2** pin functionality can be tested on system level by creating the conditions of its activation and verifying that the reaction of the device corresponds to the expected behavior.

3.5 Protection Functions: Category D

3.5.1 Operation in Verification Mode and Weak Active Mode

Verification Mode and Weak Active Mode are used to start intrusive test functions on device and system level, in order to verify during life time safety relevant functions. The following functions are supported in Verification and Weak Active Mode:

- Weak Turn-On
- DESAT Supervision Level 1
- DESAT Supervision Level 2
- DESAT Supervision Level 3
- OCP Supervision Level 1
- OCP Supervision Level 3
- UVLOx and OVLOx Supervision Level 1
- Internal Clock Supervision
- Timing Calibration Feature

Intrusive test functions can only be started once a correct sequence of SPI commands has been received after reset. The implementation of the device ensures that no intrusive function can be started when the device is normally active.

A time-out function ensures that the device quits OPM5 or OPM6 to OPM1 after a hardware defined time.

The verification functions are triggered by setting the corresponding bit fields in registers **PSCR** or **SSCR** in OPM2. The settings are then activated in OPM5. Only one verification function should be activated at the time.

Note: In OPM5 and OPM6 mode, it is recommended to have bit field **SSTOF.STVAL** programmed to 0_H.

3.5.2 Weak Turn On

The Weak-Turn On (WTO) corresponds to the operation when Mode OPM6 is active.

The purpose of the Weak Turn-On functionality is to perform a “probe” test of the IGBT, by switching it on with a reduced gate voltage, in order to limit the current through it in case of overcurrent conditions. This allows to avoid high currents when the system has no memory of the previous state.

In Mode OPM6, when the driver initiates a turn-on sequence after the reception of a PWM command, the ON voltage at signal **TON** is reduced to V_{GPN0} .

The device allows for external booster voltage compensation at the IGBT gate. When bit **SCFG.VBEC** is set, an additional V_{BE} (base emitter junction voltage of an internal pn diode) is added to the voltage at **TON** in order to compensate for the V_{BE} of an external booster.

Note: When using WTO, it is recommended to have the selected **TTOFF** (if active) plateau at a smaller voltage than the WTO voltage.

Protection and Diagnostics

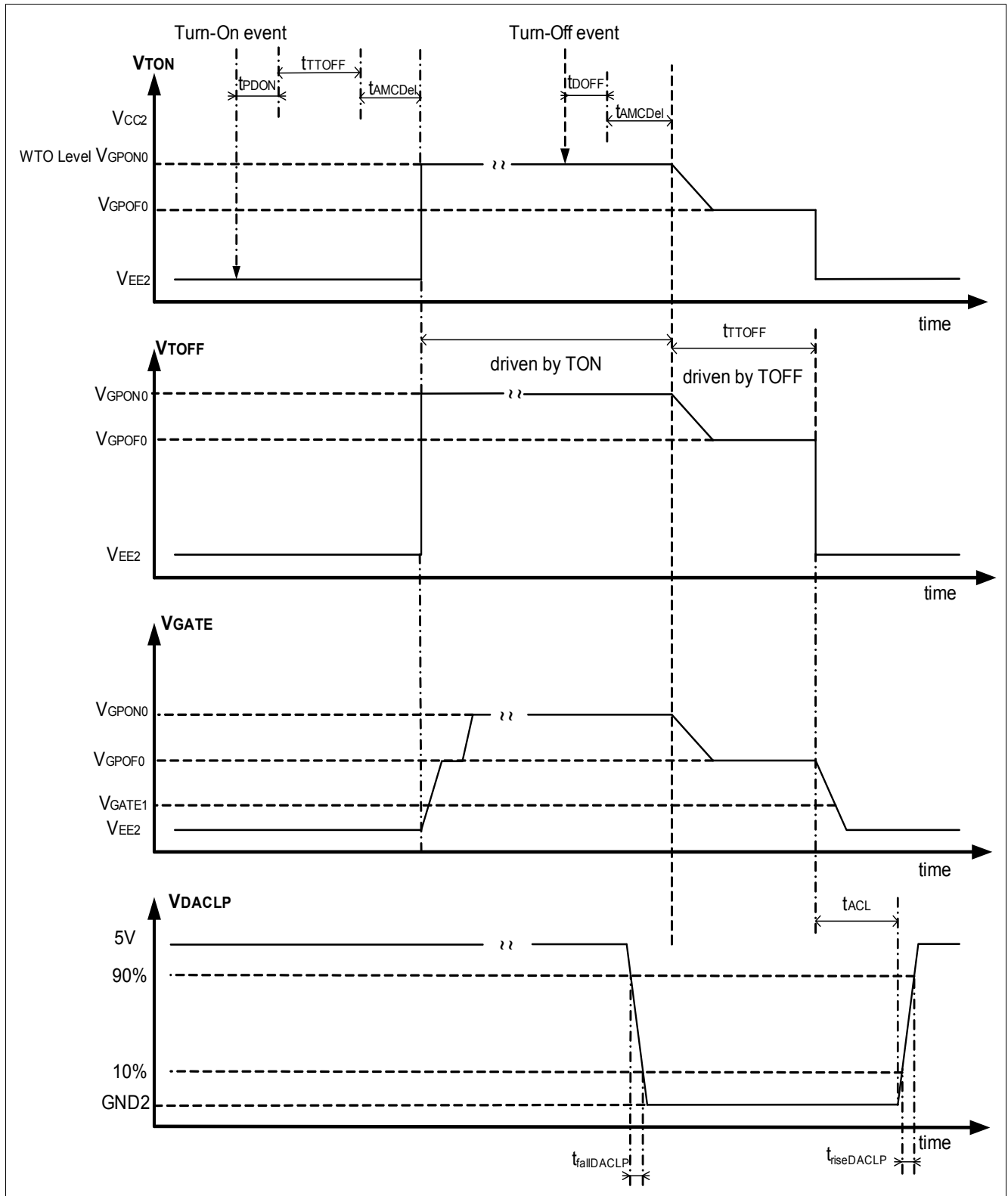

Figure 24 Idealized Weak Turn-On Sequence

Note: All Two-Level Plateaus can be programmed but only $V_{GPOF0} - V_{GPOF2}$ will be seen. In this case V_{GPOF0} was programmed to make the plateau visible.

Protection and Diagnostics

3.5.3 DESAT Supervision Level 1

The DESAT Supervision Level 1 functionality is summarized in [Table 27](#):

Table 27 DESAT Supervision Level 1 Overview

Parameter	Short Description
Function	Supervision of the DESAT functionality.
Periodicity	On request.
Action in case of failure event	N.a.
Programmability	No
In-System Testability	No

The purpose of the DESAT Supervision Level 1 function is to verify that the DESAT feature is operational over the whole life time of the application. Since the DESAT supervision is intrusive, it is intended to be executed when the device is in Mode OPM5 and OPM6 (e.g. after power-up during the initialization phase). This mechanism aims at generating artificially a DESAT error, verifying that it is recognized by the device and that an error notification is correctly issued to the primary logic.

When this function is triggered, the driver enters a special mode where the signal input of the comparator is internally pulled up above the threshold voltage (see [Figure 17](#)). The DESAT function works normally otherwise. When the device enters OPM6 and turns on, after the blanking time has elapsed, a DESAT error is generated, with the corresponding actions being triggered by the device.

The **INP** signal is issued at the output stage (weak turn-on).

3.5.4 DESAT Supervision Level 2

The DESAT Supervision Level 2 functionality is summarized in [Table 28](#):

Table 28 DESAT Supervision Level 2 Overview

Parameter	Short Description
Function	Supervision of the DESAT functionality.
Periodicity	On request.
Action in case of failure event	N.a.
Programmability	No
In-System Testability	No

The purpose of the DESAT Supervision Level 2 function is to verify that the DESAT feature is operational over the whole life time of the application. Since the DESAT supervision is intrusive, it is intended to be executed when the device is in Mode OPM5 and OPM6 (e.g. after power-up during the initialization phase). This mechanism aims at generating artificially a DESAT error, verifying that it is recognized by the device and that an error notification is correctly issued to the primary logic.

When this function is triggered, the driver enters a special mode where, as soon as the device is in OPM6 and a PWM turn-on command is received, no action is executed on the output stage. However, the DESAT logic works normally. It means that after the blanking time has elapsed, the voltage on pin DESAT should exceed the DESAT threshold level, leading to a DESAT error, with the corresponding actions being triggered by the driver.

The **INP** signal is not issued at the output stage.

Protection and Diagnostics

Note: When using DESAT supervision Level 2, bit field **SSTTOF.STVAL** must be programmed to 0_H

3.5.5 DESAT Supervision Level 3

The DESAT Supervision Level 3 functionality is summarized in [Table 29](#):

Table 29 DESAT Supervision Level 3 Overview

Parameter	Short Description
Function	Supervision of the DESAT functionality.
Periodicity	On request.
Action in case of failure event	N.a.
Programmability	No
In-System Testability	No

The purpose of the DESAT Supervision Level 3 function is to verify that the DESAT feature is operational over the whole life time of the application. Since the DESAT supervision is intrusive, it is intended to be executed when the device is in Mode OPM5 and OPM6 (e.g. after power-up during the initialization phase). This mechanism aims at generating artificially a DESAT error, verifying that it is recognized by the device and that an error notification is correctly issued to the primary logic.

When this function is triggered, the driver enters a special mode where the signal input of the comparator is internally pulled up above the threshold voltage (see [Figure 17](#)). When the device enters OPM6, independently from the PWM signal, a DESAT error is generated, with the corresponding actions being triggered by the device.

The **INP** signal is not issued at the output stage.

Note: When using DESAT supervision Level 3, bit field **SSTTOF.STVAL** **must** be programmed to 0_H

3.5.6 OCP Supervision Level 1

The OCP Supervision functionality is summarized in [Table 30](#):

Table 30 OCP Supervision Level 1 Overview

Parameter	Short Description
Function	Supervision of the OCP functionality.
Periodicity	On Request.
Action in case of failure event	N.a.
Programmability	No
In-System Testability	No

The purpose of the OCP Supervision Level 1 function is to verify that the OCP feature is operational over the whole life time of the application. Since the OCP supervision is intrusive, it is intended to be executed when the device is in Mode OPM5 and OPM6 (e.g. after power-up during the initialization phase). The main goal of this mechanism is to generate artificially an OCP error, to verify that it is recognized by the driver and that an error notification is correctly issued to the primary logic.

Protection and Diagnostics

When this function is triggered, the driver enters a special mode where the signal input of the comparator is internally pulled up above the respective threshold voltage (see [Figure 20](#)). The OCP function works normally otherwise. When the device enters OPM6 and turns on, after the blanking time has elapsed, an OCP error is generated, with the corresponding actions being triggered by the device.

The **INP** signal is issued at the output stage (weak turn-on).

3.5.7 OCP Supervision Level 3

The OCP Supervision functionality is summarized in [Table 31](#):

Table 31 OCP Supervision Level 3 Overview

Parameter	Short Description
Function	Supervision of the OCP functionality.
Periodicity	On Request.
Action in case of failure event	N.a.
Programmability	No
In-System Testability	No

The purpose of the OCP Supervision Level 3 function is to verify that the OCP feature is operational over the whole life time of the application. Since the OCP supervision is intrusive, it is intended to be executed when the device is in Mode OPM5 and OPM6 (e.g. after power-up during the initialization phase). The main goal of this mechanism is to generate artificially an OCP error, to verify that it is recognized by the driver and that an error notification is correctly issued to the primary logic.

When this function is triggered, the driver enters a special mode where the signal input of the comparator is internally pulled up above the respective threshold voltage (see [Figure 20](#)). When the device enters OPM6, independently from the PWM command, after the blanking time has elapsed, an OCP error is generated, with the corresponding actions being triggered by the device.

The **INP** signal is not issued at the output stage.

Note: When using OCP supervision Level 3, bit field **SSTOF.STVAL** must be programmed to 0_H.

3.5.8 Power Supply Monitoring Supervision

The Power Supply Monitoring Supervision monitoring functionality is summarized in [Table 32](#):

Table 32 Power Supply Monitoring Supervision Overview

Parameter	Short Description
Function	Supervision of the Power Supply Monitoring Mechanisms.
Periodicity	On Request.
Action in case of event	N.a.
Programmability	No
In-System Testability	No

The purpose of this supervision function is to verify that the Power Supply Monitoring functions (UVLO2, OVLO2, UVLO3, OVLO3) are operational over the whole life time of the application. Since this supervision is intrusive, it is intended to be executed when the device is in Mode OPM5 (e.g. after power-up during the

Protection and Diagnostics

initialization phase). The main goal of this mechanism is to generate artificially a power supply monitoring error, in order to verify that it is recognized by the driver and that an error notification is correctly issued to the primary logic.

When this function is triggered, the supervision mechanism of the power supply addressed by the command is activated. The internal threshold of the comparator delivers a “dummy” error, with the corresponding actions being triggered by the driver.

The supervision of UVLO1 is not supported by the device.

3.5.9 Internal Clock Supervision

The Primary Clock Supervision functionality is summarized in [Table 33](#):

Table 33 Primary Clock Supervision Overview

Parameter	Short Description
Function	Supervision of the frequency of OSC1 and SSOSC2.
Periodicity	On Request.
Action in case of event	N.a.
Programmability	No
In-System Testability	No

The clock supervision function consists on the primary clock supervision and the TCF feature.

Primary Clock Supervision

The purpose of this supervision function is to verify the frequency deviation of the primary clock. This function works in such a way that the PWM input signal is used to start and stop a counter clocked by OSC1. The function is activated when the device is in OPM5 or OPM6. The counter is incremented for the duration of the High level at pin **INP**. At a High-to-Low transition at pin INP, the counter is stopped, and its content is transferred to bit field **PCS.CS1**. A plausibility check can therefore be made by the logic. In case of a long **INP** pulse, the counter does not overflow but stays at the maximum value until cleared. **PCS.CS1** is cleared by setting bit **PCTRL.CLRP**.

The **INP** signal is not issued at the output stage.

Note: OSC2 is indirectly monitored by the Life Sign mechanism.

Timing Calibration Feature

The purpose of this supervision function is to measure the frequency of oscillator SSOC2. The PWM input signal is used to start and stop a counter clocked by SSOSC2. The function is activated when the device is in OPM6 (only). The counter is incremented for the duration of the High level at pin **INP**. At a High-to-Low transition at pin INP, the counter is stopped, and its content is transferred to bit field **SCS.CS2**. A plausibility check can therefore be made by the logic. In case of a long **INP** pulse, the counter does not overflow but stays at the maximum value until cleared. **SCS.CS2** is cleared by a reset event only.

The **INP** signal is not issued at the output stage.

Register Description

4 Register Description

This chapter describes the internal registers of the device. [Table 35](#) provides an overview of the implemented registers. The abbreviations shown in [Table 36](#) are used in the whole section.

Table 34 Register Address Space

Module	Base Address	End Address	Note
SPI	00 _H	1F _H	

Table 35 Register Overview

Register Short Name	Register Long Name	Offset Address	Wakeup Value	Reset Value
---------------------	--------------------	----------------	--------------	-------------

[Register Description, Primary Register Description](#)

PID	Primary ID Register	00 _H	n.a.	4911 _H
PSTAT	Primary Status Register	01 _H	n.a.	0800 _H
PSTAT2	Primary Second Status Register	02 _H	n.a.	0010 _H
PER	Primary Error Register	03 _H	n.a.	0800 _H
PCFG	Primary Configuration Register	04 _H	n.a.	00C4 _H
PCTRL	Primary Control Register	06 _H	n.a.	0001 _H
PCTRL2	Primary Second Control Register	07 _H	n.a.	0001 _H
PSCR	Primary Supervision Function Control Register	08 _H	n.a.	0001 _H
PRW	Primary Read/Write Register	09 _H	n.a.	0001 _H
PPIN	Primary Pin Status Register	0A _H	n.a.	0020 _H
PCS	Primary Clock Supervision Register	0B _H	n.a.	0001 _H

[Register Description, Secondary Registers Description](#)

SID	Secondary ID Register	10 _H	n.a.	8911 _H
SSTAT	Secondary Status Register	11 _H	n.a.	0001 _H
SSTAT2	Secondary Second Status Register	12 _H	n.a.	C001 _H
SER	Secondary Error Register	13 _H	n.a.	8000 _H
SCFG	Secondary Configuration Register	14 _H	n.a.	0190 _H
SDESAT1	Secondary DESAT Blanking Time Register	15 _H	n.a.	2000 _H
SCTRL	Secondary Control Register	16 _H	n.a.	0001 _H
SSCR	Secondary Supervision Function Control Register	17 _H	n.a.	0001 _H
SDESAT0	Secondary DESAT Blanking Time Register	18 _H	n.a.	1000 _H
SOCP	Secondary OCP Blanking Time Register	19 _H	n.a.	0001 _H
SRTTOF	Secondary Regular TTOFF Configuration Register	1A _H	n.a.	00E0 _H
SSTTOF	Secondary Safe TTOFF Configuration Register	1B _H	n.a.	2000 _H

Register Description

Table 35 Register Overview (cont'd)

Register Short Name	Register Long Name	Offset Address	Wakeup Value	Reset Value
SACL	Secondary Active Clamping Configuration Register	1E _H	n.a.	2600 _H
SCS	Secondary Clock Supervision Register	1F _H	n.a.	0001 _H

Note: The reset values can depend on pin level during reset so they might vary from given value for single registers for e.g. *PPIN*.

The registers are addressed wordwise.

Table 36 Bit Access Terminology

Mode	Symbol	Description
Basic Access Types		
read/write	rw	This bit or bit field can be written or read.
read	r	This bit or bit field is read only.
write	w	This bit or bit field is write only (read as 0 _H).
read/write hardware affected	rwh	As rw, but bit or bit field can also be modified by hardware.
read hardware affected	rh	As r, but bit or bit field can also be modified by hardware.
sticky	s	Bits with this attribute are “sticky” in one direction. If their reset value is once overwritten they can be switched again into their reset state only by a reset operation. Software and internal logic (except reset-like functions) cannot switch this type of bit into its reset state by writing directly the register. The sticky attribute can be combined to other functions (e.g. ‘rh’).
Reserved / not implemented	0	Bit fields named ‘0’ indicate not implemented functions. They have the following behavior: <ul style="list-style-type: none"> Reading these bit fields returns 0_H. Writing these bit fields has no effect. These bit fields are reserved. When writing, software should always set such bit fields to 0 _H in order to preserve compatibility with future products.
Reserved / not defined	Res	Certain bit fields or bit combinations in a bit field can be marked as ‘Reserved’, indicating that the behavior of the device is undefined for that combination of bits. Setting the register to such an undefined value may lead to unpredictable results. When writing, software must always set such bit fields to legal values.

Register Description

4.1 Primary Register Description

Primary ID Register

This register contains the identification number of the primary chip version.

PID	Offset	Wakeup Value	Reset Value
Primary ID Register	00 _H	n.a.	4911 _H

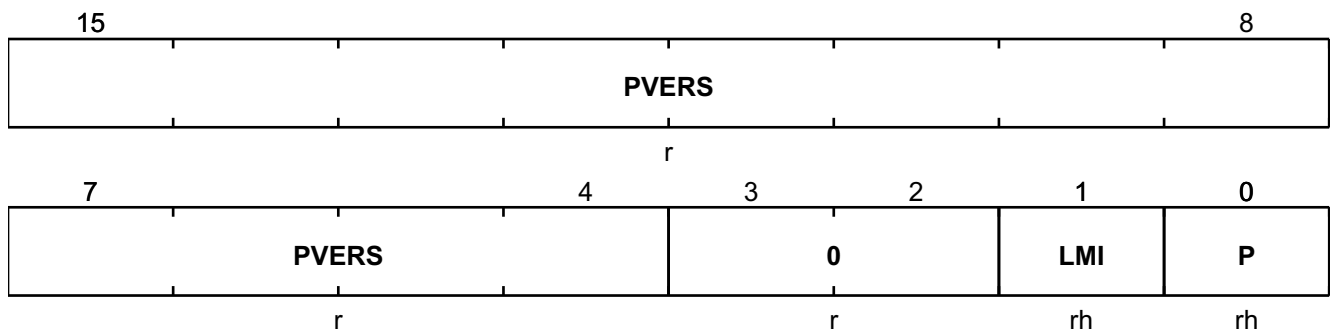

Field	Bits	Type	Description
PVERS	15:4	r	Primary Chip Identification This bit field defines the version of the primary chip. This bit field is hard-wired.
0	3:2	r	Reserved Read as 0 _B .
LMI	1	rh	Last Message Invalid Notification This bit indicates if the last received SPI Message was correctly processed by the device. 0 _B , Previous Message was processed correctly. 1 _B , Previous Message was discarded.
P	0	rh	Parity Bit Odd Parity Bit.

Register Description

Primary Status Register

This register contains information on the status of the device.

PSTAT Primary Status Register	Offset 01 _H	Wakeup Value n.a.	Reset Value 0800 _H
----------------------------------	---------------------------	----------------------	----------------------------------

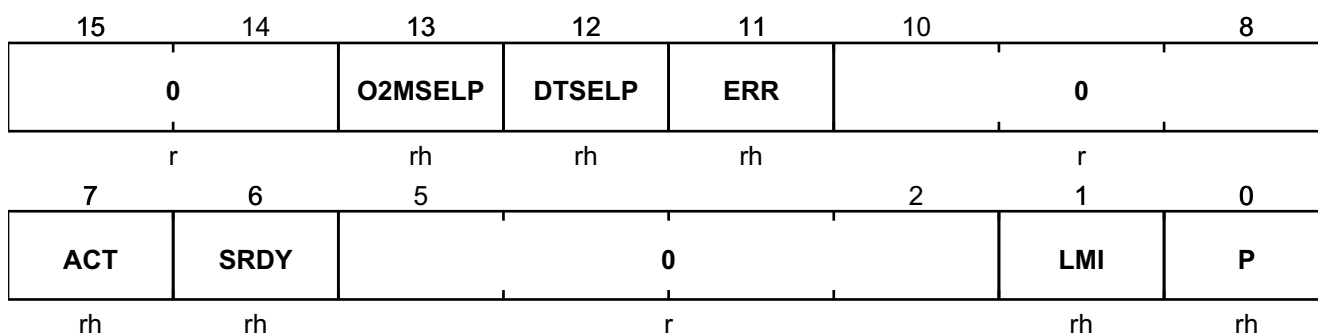

Field	Bits	Type	Description
0	15:14	r	Reserved Read as 0 _B .
O2MSELP	13	rh	OVLO2 Mode Status This bit indicates which OVLO2 Mode is active <i>Note:</i> This bit is a mirror of bit SCTRL.O2MSELS 0 _B eventBGenerationActive , Event B generation active. 1 _B eventCGenerationActive , Event C generation active.
DTSELP	12	rh	DESAT Timing Status This bit indicates which timing value for the DESAT function is active. <i>Note:</i> This bit is a mirror of bit SCTRL.DTSELS 0 _B sdesat0Active , SDESAT0 is active. 1 _B sdesat1Active , SDESAT1 is active.
ERR	11	rh	Error Status This bit is the OR combination of all bits of register PER . 0 _B noError , No error is detected. 1 _B error , An error is detected.
0	10:8	r	Reserved Read as 0 _B .
ACT	7	rh	Active State Status This bit indicates if the device is in Active State (OPM4). 0 _B notActive , The device is not in Active State. 1 _B active , The device is in Active State.

Register Description

Field	Bits	Type	Description
SRDY	6	rh	Secondary Ready Status This bit indicates if the secondary chip is ready for operation. 0 _B notReady , Secondary chip is not ready. 1 _B ready , Secondary chip is ready.
0	5:2	r	Reserved Read as 0 _B .
LMI	1	rh	Last Message Invalid Notification This bit indicates if the last received SPI Message was correctly processed by the device. 0 _B , Previous Message was processed correctly. 1 _B , Previous Message was discarded.
P	0	rh	Parity Bit Odd Parity Bit.

Register Description

Primary Second Status Register

This register contains information on the status of the device.

PSTAT2 Primary Second Status Register	Offset 02 _H	Wakeup Value n.a.	Reset Value 0010 _H
--	---------------------------	----------------------	----------------------------------

	15	14	13	12	11	10	9	8
	0		FLTBP	FLTAP	0	STP	0	HZ
	r		rh	rh	r	rh	r	rh
	7		5	4	3	2	1	0
		OPM		FLTBP	FLTA	ENVAL	LMI	P
		rh		rhs	rhs	rh	rh	rh

Field	Bits	Type	Description
0	15:14	r	Reserved Read as 0 _B .
FLTBP	13	rh	Event Class B Status This bit indicates if the conditions leading to an event Class B are met. <i>Note: This bit is a mirror of bit SSTAT.FLTBS</i> 0 _B noError , No error condition detected. 1 _B error , An error condition is detected.
FLTAP	12	rh	Event Class A Status This bit indicates if the conditions leading to an event Class A are met. <i>Note: This bit is a mirror of bit SSTAT.FLTAS</i> 0 _B noError , No error condition is detected. 1 _B error , An error condition is detected.
0	11	r	Reserved Read as 0 _B .
STP	10	rh	Shoot Through Protection Status This bit is set in case the shoot through protection inhibition time (i.e. would inhibit a PWM rising edge). 0 _B inhibitionNotActive , STP inhibition is not active. 1 _B inhibitionActive , STP inhibition is active.
0	9	r	Reserved Read as 0 _B .

Register Description

Field	Bits	Type	Description
HZ	8	rh	<p>Tristate Output Stage Status This bit is set in case the output stage is in tristate.</p> <p><i>Note:</i> This bit is a mirror of bit SSTAT.HZ</p> <p>0_B normal, The output stage is in normal operation. 1_B tristate, The output stage is tristated.</p>
OPM	7:5	rh	<p>Operating Mode This bit field indicates which operating mode is active.</p> <p><i>Note:</i> This bit field is a mirror of bit field SSTAT.OPM</p> <p>000_B opm0, Mode OPM0 is active . 001_B opm1, Mode OPM1 is active . 010_B opm2, Mode OPM2 is active. 011_B opm3, Mode OPM3 is active. 100_B opm4, Mode OPM4 is active. 101_B opm5, Mode OPM5 is active. 110_B opm6, Mode OPM6 is active. 111_B , Reserved.</p>
FLTB	4	rhs	<p>NFLTB Pin Driver Request This bit indicates what output state is driven by the device at pin NFLTB. This bit is sticky.</p> <p>0_B tristate, NFLTB is in tristate. 1_B lowLevel, A Low Level is issued at NFLTB.</p>
FLTA	3	rhs	<p>NFLTA Pin Driver Request This bit indicates what output state is driven by the device at pin NFLTA. This bit is sticky.</p> <p>0_B tristate, NFLTA is in tristate. 1_B lowLevel, A Low Level issued at NFLTA.</p>
ENVAL	2	rh	<p>EN Valid Status This bit indicates if the signal received on pin EN is valid.</p> <p>0_B notValid, A non-valid signal is detected. 1_B valid, A valid signal is detected.</p>
LMI	1	rh	<p>Last Message Invalid Notification This bit indicates if the last received SPI Message was correctly processed by the device.</p> <p>0_B , Previous Message was processed correctly. 1_B , Previous Message was discarded.</p>
P	0	rh	<p>Parity Bit Odd Parity Bit.</p>

Register Description

Primary Error Register

This register provides information on the error status of the device.

PER	Offset	Wakeup Value	Reset Value
Primary Error Register	03 _H	n.a.	0800 _H

15	14	13	12	11	10	9	8
0	O2MTO	DBTO	RSTE1	RST1	ENER	STPER	SPIER
r	rh	rh	rhs	rhs	rhs	rhs	rhs
7	6	5	4	3	2	1	0
VMTO	0	OVLO3ER	0	OSTER	CER1	LMI	P
rh	r	rh	r	rh	rhs	rh	rh

Field	Bits	Type	Description
0	15	r	Reserved Read as 0 _B .
O2MTO	14	rh	OVLO2 Time Out Flag This bit indicates an OVLO2 Mode Timeout occurred. <i>Note:</i> This bit is a mirror of bit SER.O2MTO . 0 _B notSet , No time out was detected. 1 _B set , A time out was detected.
DBTO	13	rh	DESAT Time Out Flag This bit indicates a DESAT Blanking Time Timeout occurred. <i>Note:</i> This bit is a mirror of bit SER.DBTO . 0 _B notSet , No time out was detected. 1 _B set , A time out was detected.
RSTE1	12	rhs	Primary External Hard Reset flag This bit indicates if a reset event has been detected on the primary chip due to the activation of pin NRST/RDY . This bit is sticky. 0 _B notSet , No external hard reset event has been detected. 1 _B set , An externally hard reset event has been detected.

Register Description

Field	Bits	Type	Description
RST1	11	rhs	<p>Primary Reset Flag This bit indicates if a reset event has been detected on the primary chip. This bit is sticky. 0_B notSet, No reset event has been detected. 1_B set, A reset event has been detected.</p>
ENER	10	rhs	<p>EN Signal Invalid Flag This bit indicates if an valid-to-invalid transition on signal EN has been detected. This bit is sticky. <i>Note:</i> This bit can not be cleared while an error condition is active. 0_B notSet, No event has been detected. 1_B set, An event has been detected.</p>
STPER	9	rhs	<p>Shoot Through Protection Error Flag This bit indicates if a shoot through protection error event has been detected. This bit is sticky. <i>Note:</i> This bit can not be cleared while an error condition is active (bit PSTAT2.STP set). 0_B notSet, No event has been detected. 1_B set, An event has been detected.</p>
SPIER	8	rhs	<p>SPI Error Flag This indicates if an SPI error event has been detected. This bit is sticky. 0_B notSet, No error event has been detected. 1_B set, An error event has been detected.</p>
VMTO	7	rh	<p>Verification Mode Time-Out Event Flag This bit indicates if a verification mode time-out event has been detected. <i>Note:</i> This bit is a mirror of bit SER.VMTO. 0_B notSet, No time-out event has been detected. 1_B set, A time-out event has been detected.</p>
0	6	r	<p>Reserved Read as 0_B.</p>
OVLO3ER	5	rh	<p>OVLO3 Error Flag This bit indicates if an Overvoltage Lockout event on V_{EE2} has been detected. <i>Note:</i> This bit is a mirror of bit SER.OVLO3ER. 0_B notSet, No event has been detected. 1_B set, An event has been detected.</p>

Register Description

Field	Bits	Type	Description
0	4	r	Reserved Read as 0 _B .
OSTER	3	rh	Output Stage Tristate Event Flag This bit indicates if the output stage has been tristated. <i>Note:</i> This bit is a mirror of bit SER.OSTER . 0 _B notSet , No tristate event has been detected. 1 _B set , An tristate event has been detected.
CER1	2	rhs	Primary Communication Error Flag This indicates if a loss of communication event ¹⁾ with the secondary chip has been detected by the primary chip. This bit is sticky. <i>Note:</i> This bit can not be cleared while an error condition is active (bit PSTAT2.SRDY cleared). 0 _B notSet , No event has been detected. 1 _B set , An event has been detected.
LMI	1	rh	Last Message Invalid Notification This bit indicates if the last received SPI Message was correctly processed by the device. 0 _B , Previous Message was processed correctly. 1 _B , Previous Message was discarded.
P	0	rh	Parity Bit Odd Parity Bit.

1) This bit is not set after a reset event

Register Description

Primary Configuration Register

This register is used to select the configuration of the device.

PCFG	Offset	Wakeup Value	Reset Value
Primary Configuration Register	04 _H	n.a.	00C4 _H

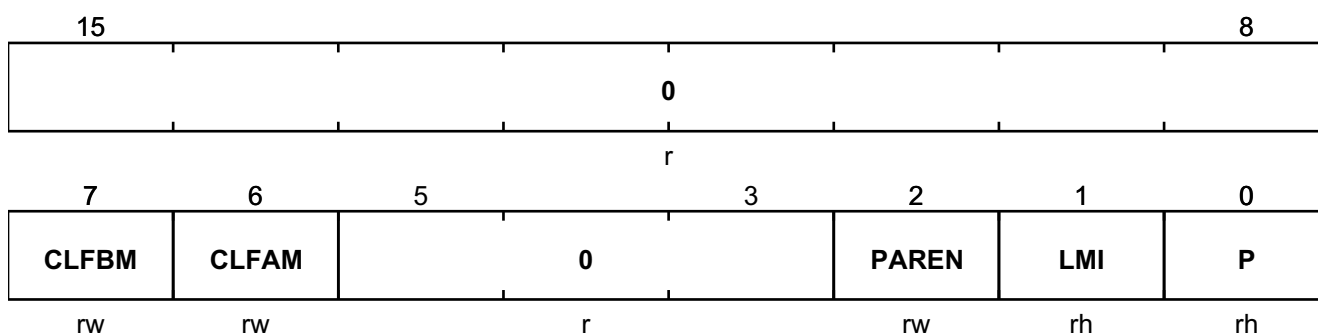

Field	Bits	Type	Description
0	15:8	r	Reserved Read as 0 _B .
CLFBM	7	rw	NFLTB Pin Clear Mode This bit defines the behavior of signal NFLTB at the reception of a clear primary command. 0 _B always , Signal NFLTB is always deasserted. 1 _B classB , Signal NFLTB is deasserted only if no EventClassBconditionisbeingdetected (see Chapter 2.4.7 for detailed description).
CLFAM	6	rw	NFLTA Pin Clear Mode This bit defines the behavior of signal NFLTA at the reception of a clear primary command. 0 _B always , Signal NFLTA is always deasserted. 1 _B classA , Signal NFLTA is deasserted only if no Event Class A condition is being detected (see Chapter 2.4.7 for detailed description).
0	5:3	r	Reserved Read as 0 _B .
PAREN	2	rw	SPI Parity Enable This bit indicates if the SPI parity error detection is active (reception only). 0 _B disabled , Parity Check is disabled. 1 _B enabled , Parity Check is enabled.
LMI	1	rh	Last Message Invalid Notification This bit indicates if the last received SPI Message was correctly processed by the device. 0 _B , Previous Message was processed correctly. 1 _B , Previous Message was discarded.

Register Description

Field	Bits	Type	Description
P	0	rh	Parity Bit Odd Parity Bit.

Register Description

Primary Control Register

This register is used to control the device during run-time.

PCTRL	Offset	Wakeup Value	Reset Value
Primary Control Register	06 _H	n.a.	0001 _H

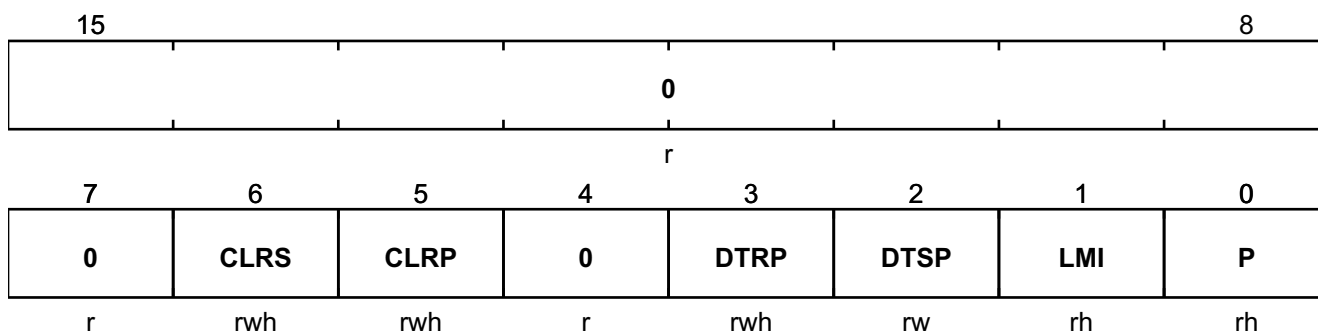

Field	Bits	Type	Description
0	15:7	r	Reserved Read as 0 _B .
CLRS	6	rwh	Clear Secondary Sticky Bits This bit is used to clear the sticky bits on the secondary side. This bit is automatically cleared by hardware. . 0 _B noAction , No action. 1 _B clear , Clear sticky bits.
CLRP	5	rwh	Clear Primary Sticky Bits This bit is used to clear the sticky bits on the primary side. This bit is automatically cleared by hardware. . 0 _B noAction , No action. 1 _B clear , Clear sticky bits and deassert signals NFLTA and NFLTB .
0	4	r	Reserved Read as 0 _B .
DTRP	3	rwh	Primary Desat Timing Refresh Request This bit is used to refresh the DESAT timing watchdog. <i>Note: This bit is automatically cleared by hardware.</i> 0 _B noAction , No action. 1 _B refresh , Request a refresh of watchdog.

Register Description

Field	Bits	Type	Description
DTSP	2	rw	<p>Primary Desat Timing Selection Request This bit indicates which timing value for the DESAT function is requested.</p> <p>0_B sdesat0Request, SDESAT0 selection request. 1_B sdesat1Request, SDESAT1 selection request.</p>
LMI	1	rh	<p>Last Message Invalid Notification This bit indicates if the last received SPI Message was correctly processed by the device.</p> <p>0_B , Previous Message was processed correctly. 1_B , Previous Message was discarded.</p>
P	0	rh	<p>Parity Bit Odd Parity Bit.</p>

Register Description

Primary Second Control Register

This register is used to control the device during run-time.

PCTRL2	Offset	Wakeup Value	Reset Value
Primary Second Control Register	07 _H	n.a.	0001 _H

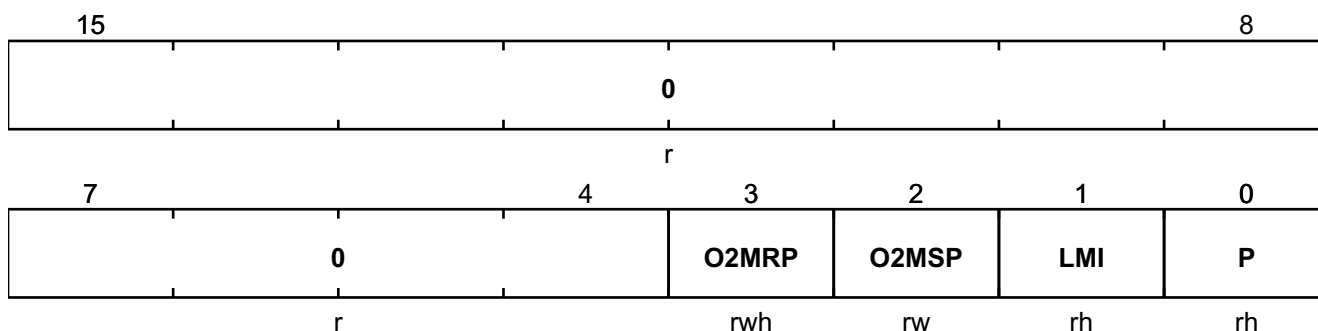

Field	Bits	Type	Description
0	15:4	r	Reserved Read as 0 _B .
O2MRP	3	rwh	Primary OVLO2 Mode Refresh Request This bit is used to refresh the OVLO2 Mode watchdog. <i>Note: This bit is automatically cleared by hardware.</i> 0 _B noAction , No action. 1 _B refresh , Request a refresh of watchdog.
O2MSP	2	rw	Primary OVLO2 Mode Selection Request This bit indicates which OVLO2 Mode is requested. 0 _B modeB , selection request. 1 _B modeC , selection request.
LMI	1	rh	Last Message Invalid Notification This bit indicates if the last received SPI Message was correctly processed by the device. 0 _B , Previous Message was processed correctly. 1 _B , Previous Message was discarded.
P	0	rh	Parity Bit Odd Parity Bit.

Register Description

Primary Supervision Function Control Register

This register is used to trigger the verification functions on the primary side.

PSCR	Offset	Wakeup Value	Reset Value
Primary Supervision Function Control Register	08 _H	n.a.	0001 _H

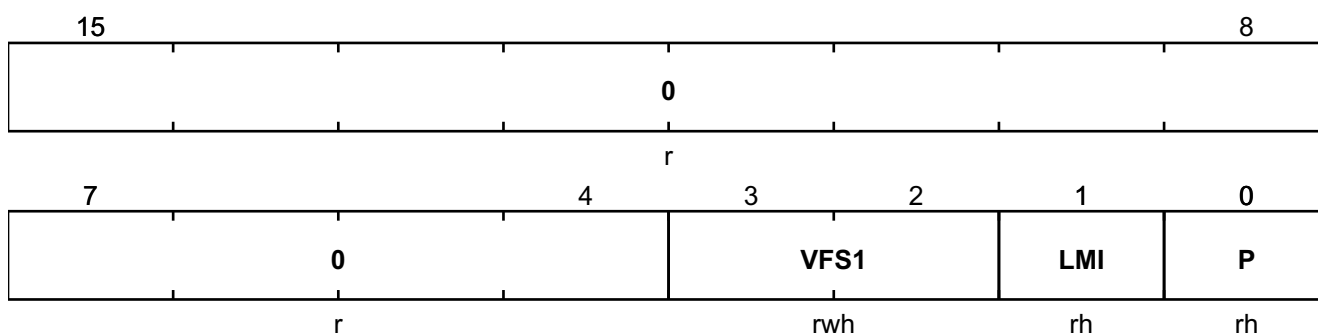

Field	Bits	Type	Description
0	15:4	r	Reserved Read as 0 _B .
VFS1	3:2	rwh	Primary Verification Function This bit field is used to activate the primary verification functions. <i>Note:</i> The selection defined by this bit field is only effective when the device enters Mode OPM5. This bit field is automatically cleared when entering OPM1. 00 _B disabled , No function activated. 01 _B , Reserved. 10 _B primaryClockSupervision , Primary Clock Supervision active. 11 _B , Reserved.
LMI	1	rh	Last Message Invalid Notification This bit indicates if the last received SPI Message was correctly processed by the device. 0 _B , Previous Message was processed correctly. 1 _B , Previous Message was discarded.
P	0	rh	Parity Bit Odd Parity Bit.

Register Description

Primary Read/Write Register

This register provides a readable and writable address space for data integrity test during runtime. This register is not associated with any hardware functionality.

PRW	Offset	Wakeup Value	Reset Value
Primary Read/Write Register	09 _H	n.a.	0001 _H

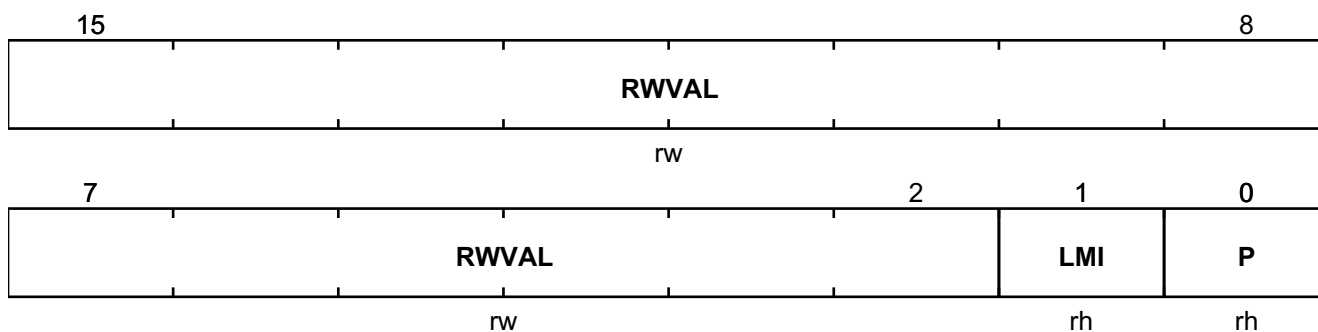

Field	Bits	Type	Description
RWVAL	15:2	rw	Data Integrity Test Register This bit field is “don’t care” for the device.
LMI	1	rh	Last Message Invalid Flag This bit indicates if the last received SPI Message was correctly processed by the device. 0 _B noError , Previous Message processed correctly. 1 _B error , Previous Message not processed.
P	0	rh	Parity Bit Odd Parity Bit.

Register Description

Primary Pin Status Register

This register provides status information on the I/Os of the primary chip.

PPIN	Offset	Wakeup Value	Reset Value
Primary Pin Status Register	0A _H	n.a.	0020 _H

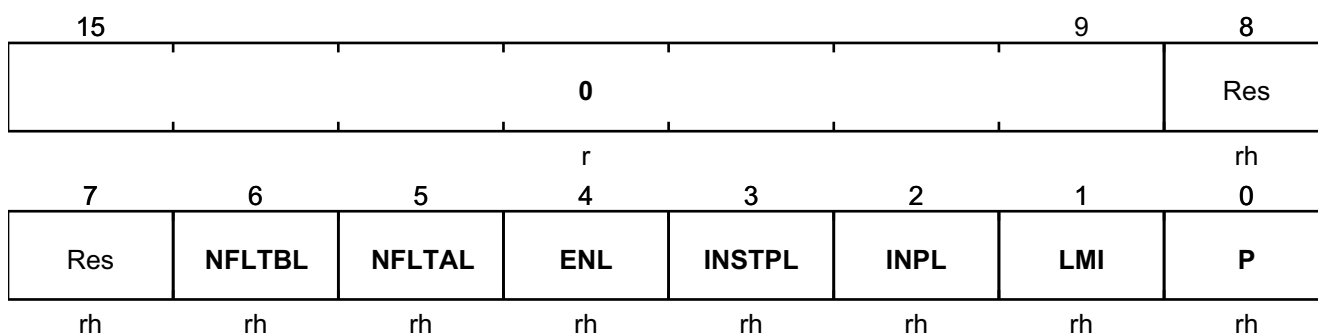

Field	Bits	Type	Description
0	15:9	r	Reserved Read as 0 _B .
Res	8:7	rh	Reserved This bit field is reserved.
NFLTBL	6	rh	NFLTBL pin level This bit indicates the logical level read on pin NFLTBL . 0 _B low , Low-level is detected. 1 _B high , High-level is detected.
NFLTAL	5	rh	NFLTAL pin Level This bit indicates the logical level read on pin NFLTAL . 0 _B low , Low-level is detected. 1 _B high , High-level is detected.
ENL	4	rh	EN Pin Level This bit indicates the logical level read on pin EN . 0 _B low , Low-level is detected. 1 _B high , High-level is detected.
INSTPL	3	rh	INSTPL Pin Level This bit indicates the logical level read on pin INSTPL . 0 _B low , Low-level is detected. 1 _B high , High-level is detected.
INPL	2	rh	INPL Pin Level This bit indicates the logical level read on pin INPL . 0 _B low , Low-level is detected. 1 _B high , High-level is detected.

Register Description

Field	Bits	Type	Description
LMI	1	rh	<p>Last Message Invalid Notification This bit indicates if the last received SPI Message was correctly processed by the device.</p> <p>0_B noError, Previous Message was processed correctly.</p> <p>1_B error, Previous Message was discarded.</p>
P	0	rh	<p>Parity Bit Odd Parity Bit.</p>

Register Description

Primary Clock Supervision Register

This register shows the result of the Primary Clock Supervision function.

PCS	Offset	Wakeup Value	Reset Value
Primary Clock Supervision Register	0B _H	n.a.	0001 _H

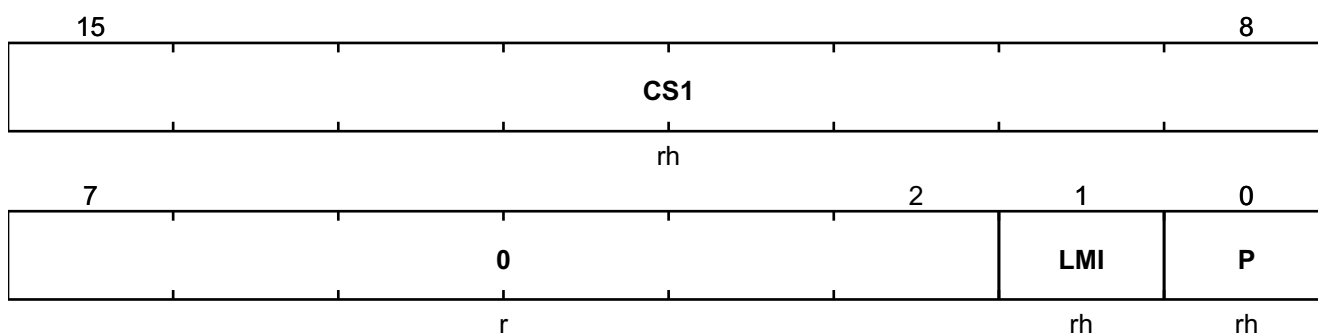

Field	Bits	Type	Description
CS1	15:8	rh	<p>Primary Clock Supervision This bit field is written by hardware by the Primary Clock Supervision function and gives the number of measured OSC1 clock cycles.</p> <p><i>Note: This bit field can be cleared by setting bit PCTRL.CLRP.</i></p>
0	7:2	r	<p>Reserved Read as 0_B.</p>
LMI	1	rh	<p>Last Message Invalid Notification This bit indicates if the last received SPI Message was correctly processed by the device. 0_B , Previous Message was processed correctly. 1_B , Previous Message was discarded.</p>
P	0	rh	<p>Parity Bit Odd Parity Bit.</p>

Register Description

4.2 Secondary Registers Description

Secondary ID Register

This register contains the identification number of secondary chip version.

SID	Offset	Wakeup Value	Reset Value
Secondary ID Register	10 _H	n.a.	8911 _H

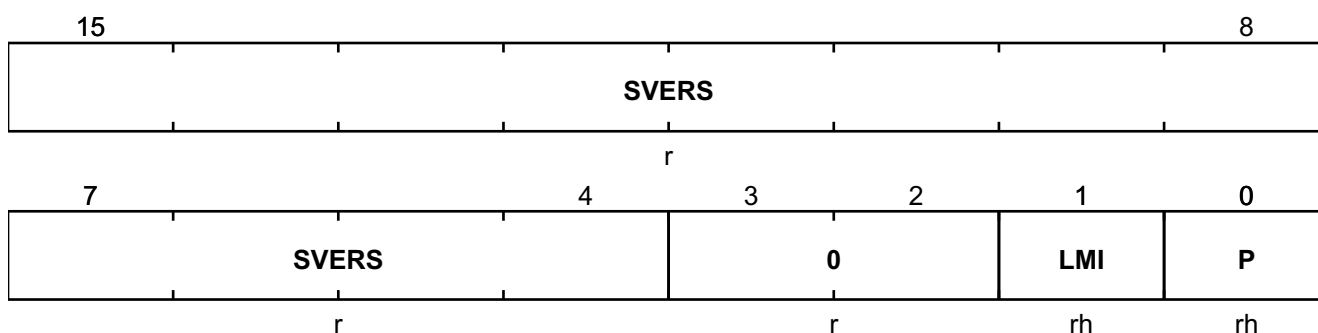

Field	Bits	Type	Description
SVERS	15:4	r	Secondary Chip Identification This bit field defines the version of the secondary chip. This bit field is hard-wired.
0	3:2	r	Reserved Read as 0 _B .
LMI	1	rh	Last Message Invalid Notification This bit indicates if the last received SPI Message was correctly processed by the device. 0 _B , Previous Message was processed correctly. 1 _B , Previous Message was discarded.
P	0	rh	Parity Bit Odd Parity Bit.

Register Description

Secondary Status Register

This register contains information on the status of the device.

SSTAT	Offset	Wakeup Value	Reset Value
Secondary Status Register	11 _H	n.a.	0001 _H

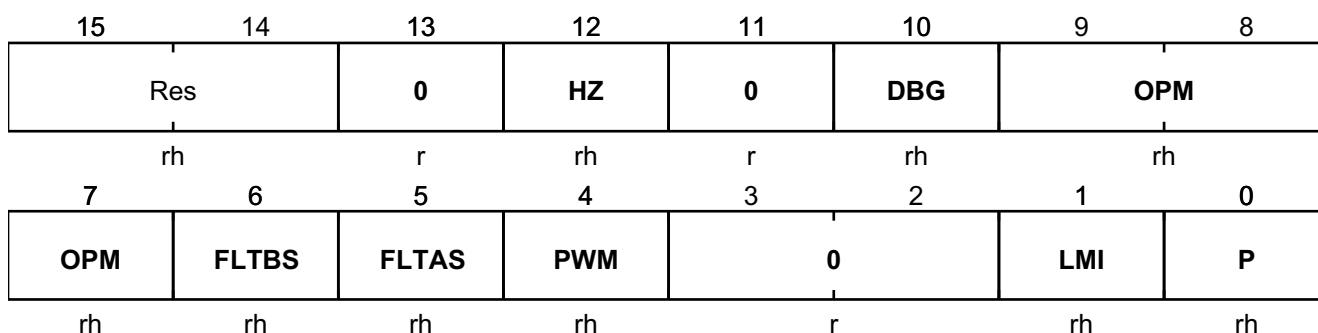

Field	Bits	Type	Description
Res	15:14	rh	Reserved This bit field is reserved.
0	13	r	Reserved Read as 0 _B .
HZ	12	rh	Output Stage Status This bit indicates the state of the output stage. 0 _B normal , The output stage is operating normally. 1 _B tristate , The output stage is tristated.
0	11	r	Reserved Read as 0 _B .
DBG	10	rh	Debug Mode Active Flag This bit indicates if the Debug Mode is active. 0 _B notSet , Debug Mode is not active. 1 _B set , Debug Mode is active.
OPM	9:7	rh	Operating Mode This bit field indicates in which operating mode is active. The coding is identical to PSTAT2.OPM . The bits are volatile. The recommended read out should be via PSTAT2.OPM .
FLTBS	6	rh	Event Class B Status This bit indicates if the conditions leading to an Event Class B are detected. 0 _B notSet , Event conditions are not met. 1 _B set , Event conditions are met.
FLTAS	5	rh	Event Class A Status This bit indicates if the conditions leading to an Event Class A are detected. 0 _B notSet , Event conditions are not met. 1 _B set , Event conditions are met.

Register Description

Field	Bits	Type	Description
PWM	4	rh	PWM Command Status This bit indicates the status of the PWM command received from the primary side. 0 _B off , PWM OFF command is detected. 1 _B on , PWM ON command is detected.
0	3:2	r	Reserved Read as 0 _B .
LMI	1	rh	Last Message Invalid Notification This bit indicates if the last received SPI Message was correctly processed by the device. 0 _B , Previous Message was processed correctly. 1 _B , Previous Message was discarded.
P	0	rh	Parity Bit Odd Parity Bit.

Register Description

Secondary Second Status Register

This register contains information on the status of the device.

SSTAT2 Secondary Second Status Register	Offset 12 _H	Wakeup Value n.a.	Reset Value C001 _H
--	---------------------------	----------------------	----------------------------------

15	14	13	12	11	10	9	8
AMCLPL	DACLPL	GC2	GC1	OVLO3M	UVLO3M	OVLO2M	UVLO2M
rh	rh	rh	rh	rh	rh	rh	rh
7	6	5	4	3	2	1	0
0	OCPC1	OSDL	DSATC	0		LMI	P
r	rh	rh	rh	r		rh	rh

Field	Bits	Type	Description
AMCLPL	15	rh	AMCLP Pin output Level This bit indicates the level read at pin AMCLP . 0 _B low , AMCLP level is Low. 1 _B high , AMCLP level is High.
DACLPL	14	rh	DACLP Pin output level This bit indicates the level read at pin DACLP . 0 _B low , DACLP level is Low. 1 _B high , DACLP level is High.
GC2	13	rh	Gate Second Comparator Status This bit shows the output of the second comparator of the Gate Monitoring function. 0 _B belowVgate2 , GATE voltage is below V _{GATE2L} . 1 _B aboveVgate2 , GATE voltage is above V _{GATE2H} .
GC1	12	rh	Gate First Comparator Status This bit indicates the output of the first comparator of the Gate Monitoring function. 0 _B belowVgate1 , GATE voltage is below V _{GATE1L} . 1 _B aboveVgate1 , GATE voltage is above V _{GATE1H} .
OVLO3M	11	rh	OVLO3 Event This bit indicates the result of the OVLO3 monitoring function. 0 _B noError , No failure condition is detected. 1 _B error , One failure condition is detected.
UVLO3M	10	rh	UVLO3 Event This bit indicates the result of the UVLO3 monitoring function. 0 _B noError , No failure condition is detected. 1 _B error , One failure condition is detected.

Register Description

Field	Bits	Type	Description
OVLO2M	9	rh	OVLO2 Monitoring Result This bit indicates the result of the OVLO2 monitoring function. 0 _B noError , No failure condition is detected. 1 _B error , One failure condition is detected.
UVLO2M	8	rh	UVLO2 Monitoring Result This bit indicates the result of the UVLO2 monitoring function. 0 _B noError , No failure condition is detected. 1 _B error , One failure condition is detected.
0	7	r	Reserved Read as 0 _B .
OCPC1	6	rh	OCP Comparator Result This bit indicates the (blanked) output of the comparator of the OCP function. 0 _B belowThreshold , OCP voltage is below V _{OCPD1} . 1 _B aboveThreshold , OCP voltage is above V _{OCPD1} .
OSDL	5	rh	OSD Level This bit indicates the level read at pin OSD. 0 _B low , OSD level is Low. 1 _B high , OSD level is High.
DSATC	4	rh	DESAT Comparator Result This bit indicates the output of the comparator of the DESAT function. 0 _B belowThreshold , DESAT voltage is below the internal threshold. 1 _B aboveThreshold , DESAT voltage is above the internal threshold.
0	3:2	r	Reserved Read as 0 _B .
LMI	1	rh	Last Message Invalid Notification This bit indicates if the last received SPI Message was correctly processed by the device. 0 _B , Previous Message was processed correctly. 1 _B , Previous Message was discarded.
P	0	rh	Parity Bit Odd Parity Bit.

Register Description

Secondary Error Register

This register provides information on the error status of the device.

SER	Offset	Wakeup Value	Reset Value
Secondary Error Register	13 _H	n.a.	8000 _H

15	14	13	12	11	10	9	8
RST2	OCPER	DESATER	UVLO2ER	OVLO2ER	UVLO3ER	VMTO	O2MTO
rhs	rhs	rhs	rhs	rhs	rhs	rhs	rhs
7	6	5	4	3	2	1	0
OVLO3ER	DBTO	OSTER	CER2	0	LMI	P	
rhs	rhs	rhs	rhs	r	rh	rh	

Field	Bits	Type	Description
RST2	15	rhs	<p>Secondary Hard Reset Flag This bit indicates if a hard reset event has been detected on the secondary chip (due to a V_{CC2} power-up). This bit is sticky. 0_B notSet, No hard reset event has been detected. 1_B set, A hard reset event has been detected.</p>
OCPER	14	rhs	<p>OCP Error Flag This bit indicates if an OCP event has been detected. This bit is sticky. <i>Note: This bit can not be cleared while an error condition is active (bit SSTAT2.OCPC1 set).</i> 0_B notSet, No event has been detected. 1_B set, An event has been detected.</p>
DESATER	13	rhs	<p>DESAT Error Flag This bit indicates if a DESAT event has been detected. This bit is sticky. 0_B notSet, No event has been detected. 1_B set, An event has been detected.</p>

Register Description

Field	Bits	Type	Description
UVLO2ER	12	rhs	<p>UVLO2 Error Flag This bit indicates if an Undervoltage Lockout event (on V_{CC2}) has been detected. This bit is sticky.</p> <p><i>Note:</i> This bit can not be cleared while an error condition is active (bit SSTAT2.UVLO2M set).</p> <p>0_B notSet, No event has been detected. 1_B set, An event has been detected.</p>
OVLO2ER	11	rhs	<p>OVLO2 Error Flag This bit indicates if an Overvoltage Lockout event (on V_{CC2}) has been detected. This bit is sticky.</p> <p><i>Note:</i> This bit can not be cleared while an error condition is active (bit SSTAT2.OVLO2M set).</p> <p>0_B notSet, No event has been detected. 1_B set, An event has been detected.</p>
UVLO3ER	10	rhs	<p>UVLO3 Error Flag This bit indicates if an Undervoltage Lockout event (on V_{EE2}) has been detected. This bit is sticky.</p> <p><i>Note:</i> This bit can not be cleared while an error condition is active (bit SSTAT2.UVLO3M set).</p> <p>0_B notSet, No event has been detected. 1_B set, An event has been detected.</p>
VMTO	9	rhs	<p>Verification Mode Time-Out Event Flag This bit indicates if time-out event in Verification Mode has been detected. This bit is sticky.</p> <p>0_B notSet, No event has been detected. 1_B set, An event has been detected.</p>
O2MTO	8	rhs	<p>OVLO2 Mode Time Out This bit indicates a OVLO2 Mode Timeout occurred. This bit is sticky.</p> <p>0_B notSet, No event has been detected. 1_B set, An event has been detected.</p>
OVLO3ER	7	rhs	<p>OVLO3 Error Flag This bit indicates if an Overvoltage Lockout event (on V_{EE2}) has been detected. This bit is sticky.</p> <p><i>Note:</i> This bit can not be cleared while an error condition is active (bit SSTAT2.OVLO3M set).</p> <p>0_B notSet, No event has been detected. 1_B set, An event has been detected.</p>

Register Description

Field	Bits	Type	Description
DBTO	6	rhs	<p>DESAT Time Out This bit indicates a DESAT Blanking Time Timeout occurred.</p> <p><i>Note: This bit is a sticky.</i></p> <p>0_B notSet, No event has been detected. 1_B set, An event has been detected.</p>
OSTER	5	rhs	<p>Output Stage Tristate Event Flag This bit indicates if an output stage tristate event has been detected. This bit is sticky.</p> <p><i>Note: This bit can not be cleared if bit SSTAT.HZ is set.</i></p> <p>0_B notSet, No event has been detected. 1_B set, An event has been detected.</p>
CER2	4	rhs	<p>Communication Error Secondary Flag This indicates if a loss of communication event with the primary chip has been detected by the secondary chip. This bit is sticky.</p> <p>0_B notSet, No event has been detected. 1_B set, An event has been detected.</p>
0	3:2	r	<p>Reserved Read as 0_B.</p>
LMI	1	rh	<p>Last Message Invalid Notification This bit indicates if the last received SPI Message was correctly processed by the device.</p> <p>0_B , Previous Message was processed correctly. 1_B , Previous Message was discarded.</p>
P	0	rh	<p>Parity Bit Odd Parity Bit.</p>

Register Description

Secondary Configuration Register

This register is used to select the configuration of the device.

SCFG	Offset	Wakeup Value	Reset Value
Secondary Configuration Register	14 _H	n.a.	0190 _H

15		12		11		10		9		8	
AMCLD				UVLO3D		TOSEN		PSEN		DSTCEN	
rw				rw		rw		rw		rw	
7		6		5		4		3		2	
OVLO3D		0		Res		VBEC		0		LMI	
rw		r		rwh		rw		r		rh	

Field	Bits	Type	Description
AMCLD	15:12	rw	<p>Active Miller Clamping Delay This bit field defines the turn on delay t_{AMCDeL}. For range 0_H-F_H the following formular can be used [formular: value*2/fclk2; unit:Seconds].</p> <p><i>Note:</i> This bit field is parity protected.</p> <p>0_H disabled, AMCLP delay disabled.</p>
UVLO3D	11	rw	<p>UVLO3 Function disabled This bit disables UVLO3 monitoring.</p> <p><i>Note:</i> This bit field is parity protected.</p> <p>0_B enabled, UVLO3 monitoring is enabled. (default) 1_B disabled, UVLO3 monitoring is disabled.</p>
TOSEN	10	rw	<p>Verification Mode Time-Out Duration This bit selects the duration of the verification mode timeout.</p> <p>0_B regular, Regular time-out value (typ. 15 ms). 1_B slow, Slow time-out value (typ. 60 ms).</p>
PSEN	9	rw	<p>Pulse Suppressor Enable This bit enables the internal pulse suppressor.</p> <p>0_B disabled, Pulse suppressor is disabled. (default) 1_B enabled, Pulse suppressor is enabled.</p>
DSTCEN	8	rw	<p>DESAT Clamping Enable This bit enables the internal clamping (to GND2) of the DESAT pin during PWM OFF commands.</p> <p>0_B disabled, DESAT clamping is disabled. 1_B enabled, DESAT clamping is enabled. (default)</p>

Register Description

Field	Bits	Type	Description
OVLO3D	7	rw	<p>OVLO3 Function disabled This bit disables OVLO3 function.</p> <p><i>Note: This bit field is parity protected.</i></p> <p>0_B enabled, OVLO3 is enabled. 1_B disabled, OVLO3 is disabled. (default)</p>
Res	6	rwh	<p>Reserved This bit field is reserved and shall be written with 0_B.</p>
0	5	r	<p>Reserved Read as 0_B.</p>
VBEC	4	rw	<p>VBE Compensation Enable This bit enables the V_{BE} compensation of the TTOFF, TTON and WTO plateau levels.</p> <p>0_B disabled, V_{BE} Compensation disabled. 1_B enabled, V_{BE} Compensation enabled. (default)</p>
0	3:2	r	<p>Reserved Read as 0_B.</p>
LMI	1	rh	<p>Last Message Invalid Notification This bit indicates if the last received SPI Message was correctly processed by the device.</p> <p>0_B , Previous Message was processed correctly. 1_B , Previous Message was discarded.</p>
P	0	rh	<p>Parity Bit Odd Parity Bit.</p>

Register Description

Secondary DESAT Blanking Time Register 1

This register configures the blanking time of the DESAT function.

SDESAT1	Offset	Wakeup Value	Reset Value
Secondary DESAT Blanking Time Register	15 _H	n.a.	2000 _H

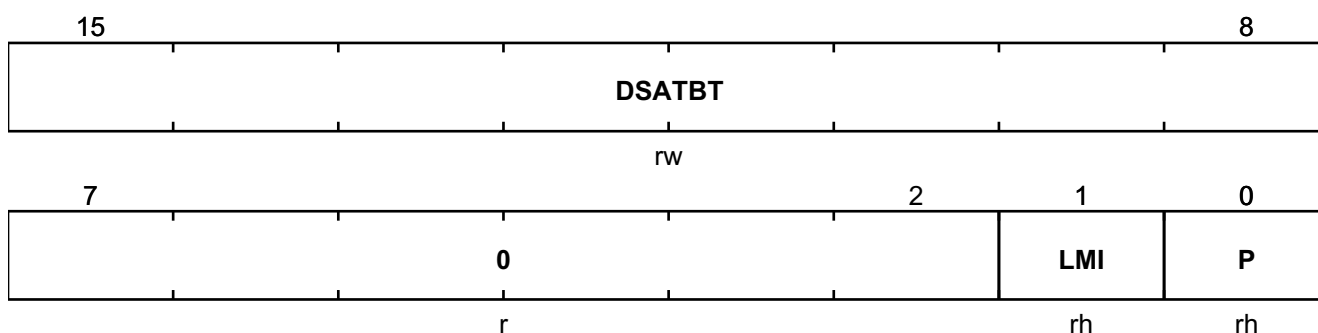

Field	Bits	Type	Description
DSATBT	15:8	rw	DESAT Blanking Time Value This bit field defines the blanking time of the DESAT function (in OSC2 clock cycles). If the DESAT function is used, a value of at least A _H shall be programmed. [formula: (value+2)/fclk2; unit:Seconds] <i>Note: This bit field is parity protected.</i>
0	7:2	r	Reserved Read as 0 _B .
LMI	1	rh	Last Message Invalid Notification This bit indicates if the last received SPI Message was correctly processed by the device. 0 _B , Previous Message was processed correctly. 1 _B , Previous Message was discarded.
P	0	rh	Parity Bit Odd Parity Bit.

Register Description

Secondary Control Register

This register is used to control the device during run-time.

SCTRL	Offset	Wakeup Value	Reset Value
Secondary Control Register	16 _H	n.a.	0001 _H

15	14	13	12	11	10	8
DTSELS	DTRS	DTSS	0	CLRS	0	
rh	rh	rh	rh	rh	rh	
7	6	5	4	3	2	1
0	O2MSELS	O2MRS	O2MSS	0	LMI	P
rh	rh	rh	rh	r	rh	rh

Field	Bits	Type	Description
DTSELS	15	rh	Secondary Desat Timing Selection Status This bit indicates which value for the DESAT function is selected. 0 _B sdesat0Active , SDESAT0 is active. 1 _B sdesat1Active , SDESAT1 is active.
DTRS	14	rh	Secondary Desat Timing Refresh Request This bit is used to refresh the DESAT timing watchdog. <i>Note: This bit field is a mirror of PCTRL.DTRP.</i> 0 _B noAction , No action. 1 _B refresh , Request a refresh of watchdog.
DTSS	13	rh	Secondary Desat Timing Selection Request This bit indicates which timnig value for the DESAT function is requested. <i>Note: This bit field is a mirror of PCTRL.DTSP.</i> 0 _B sdesat0Request , SDESAT0 selection request. 1 _B sdesat1Request , SDESAT1 selection request.
0	12	rh	Reserved Read as 0 _B .
CLRS	11	rh	Secondary Clear Request Bit This bit is set by writing PCTRL.CLRS.
0	10:7	rh	Reserved Read as 0 _B .

Register Description

Field	Bits	Type	Description
O2MSELS	6	rh	<p>Secondary OVLO2 Mode Selection Status This bit indicates which value for the OVLO2 mode is selected.</p> <p>0_B classBEvent, OVLO2 generation of class B event selected. 1_B classCEvent, OVLO2 generation of class C event selected.</p>
O2MRS	5	rh	<p>Secondary OVLO2 Mode Refresh Request This bit is used to refresh the OVLO2 timing watchdog.</p> <p><i>Note: This bit field is a mirror of PCTRL2.O2MRP.</i></p> <p>0_B noAction, No action. 1_B refresh, Request a refresh of watchdog.</p>
O2MSS	4	rh	<p>Secondary OVLO2 Mode Selection Request This bit indicates which mode for the OVLO2 function is requested to be selected.</p> <p><i>Note: This bit field is a mirror of PCTRL2.O2MSP.</i></p> <p>0_B modeB, selection request. 1_B modeC, selection request.</p>
0	3:2	r	<p>Reserved Read as 0_B.</p>
LMI	1	rh	<p>Last Message Invalid Notification This bit indicates if the last received SPI Message was correctly processed by the device.</p> <p>0_B , Previous Message was processed correctly. 1_B , Previous Message was discarded.</p>
P	0	rh	<p>Parity Bit Odd Parity Bit.</p>

Register Description

Secondary Supervision Function Control Register

This register is used to trigger the verification functions on the secondary side.

SSCR	Offset	Wakeup Value	Reset Value
Secondary Supervision Function Control Register	17 _H	n.a.	0001 _H

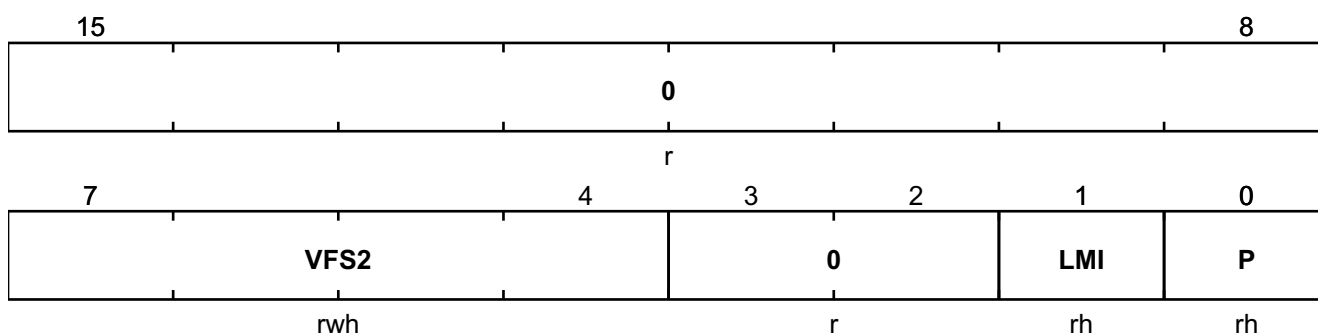

Field	Bits	Type	Description
0	15:8	r	Reserved Read as 0 _B .
VFS2	7:4	rwh	<p>Secondary Verification Function Selection This bit field is used to activate the secondary verification function. All other bit combinations are reserved.</p> <p><i>Note:</i> The selection defined by this bit field is only effective when the device enters Mode OPM5. This bit field is automatically cleared when entering OPM1.</p> <p>0_H disabled, No function activated. 1_H desatLevel1, DESAT Supervision Level 1 active. 2_H desatLevel2, DESAT Supervision Level 2 active. 3_H ocpLevel1, OCP Supervision Level 1 active. 4_H uvlo2Enabled, UVLO2 Supervision active. 5_H ovlo2Enabled, OVLO2 Supervision active. 6_H uvlo3Enabled, UVLO3 Supervision active. 7_H ovlo3Enabled, OVLO3 Supervision active. 8_H tcf, TCF function active. 9_H desatLevel3, DESAT Supervision Level 3 active. A_H ocpLevel3, OCP Supervision Level 3 active.</p>
0	3:2	r	Reserved Read as 0 _B .
LMI	1	rh	<p>Last Message Invalid Notification This bit indicates if the last received SPI Message was correctly processed by the device.</p> <p>0_B , Previous Message was processed correctly. 1_B , Previous Message was discarded.</p>

Register Description

Field	Bits	Type	Description
P	0	rh	Parity Bit Odd Parity Bit.

Register Description

Secondary DESAT Blanking Time Register 0

This register configures the blanking time of the DESAT function.

SDESAT0	Offset	Wakeup Value	Reset Value
Secondary DESAT Blanking Time Register	18 _H	n.a.	1000 _H

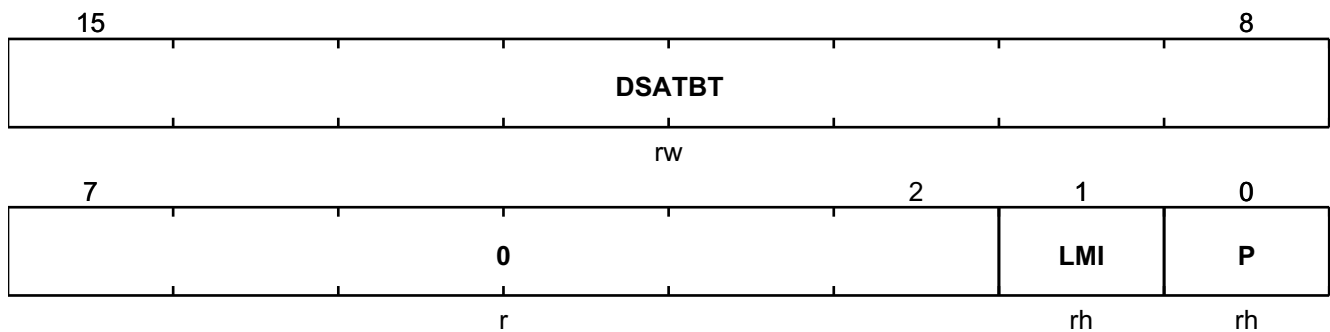

Field	Bits	Type	Description
DSATBT	15:8	rw	<p>DESAT Blanking Time Value This bit field defines the blanking time of the DESAT function (in OSC2 clock cycles). If the DESAT function is used, a value of at least A_H shall be programmed. [formular: (value+2)/fclk2; unit:Seconds]</p> <p><i>Note: This bit field is parity protected.</i></p>
0	7:2	r	<p>Reserved Read as 0_B.</p>
LMI	1	rh	<p>Last Message Invalid Notification This bit indicates if the last received SPI Message was correctly processed by the device. 0_B , Previous Message was processed correctly. 1_B , Previous Message was discarded.</p>
P	0	rh	<p>Parity Bit Odd Parity Bit.</p>

Register Description

Secondary OCP Blanking Time Register

This register configures the blanking time of the OCP function.

SOCP	Offset	Wakeup Value	Reset Value
Secondary OCP Blanking Time Register	19 _H	n.a.	0001 _H

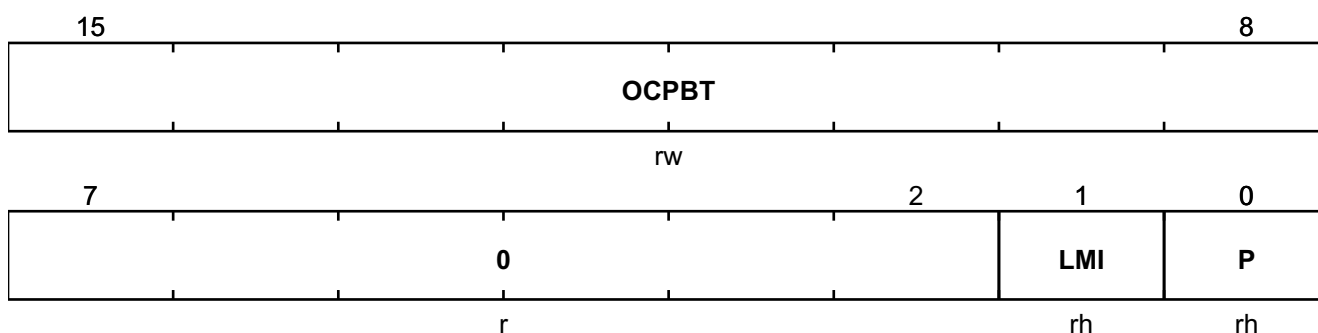

Field	Bits	Type	Description
OCPBT	15:8	rw	<p>OCP Blanking Time Value This bit field defines the blanking time of the OCP function (in OSC2 clock cycles). [formular: (value+2)/fclk2; unit:Seconds]</p> <p><i>Note:</i> This bit field is parity protected. A value greater 0 need to be programmed if OCP feature is used. The maximum value should be 0xFE. It should be considered that there is a jitter of max. +1 OSC2 clock cycle.</p> <p>0_H disabled, Digital blanking time generation disabled.</p>
0	7:2	r	<p>Reserved Read as 0_B.</p>
LMI	1	rh	<p>Last Message Invalid Notification This bit indicates if the last received SPI Message was correctly processed by the device. 0_B , Previous Message was processed correctly. 1_B , Previous Message was discarded.</p>
P	0	rh	<p>Parity Bit Odd Parity Bit.</p>

Register Description

Secondary Regular TTOFF Configuration Register

This register shows the configuration of the TTOFF function for regular turn-off.

SRTTOF	Offset	Wakeup Value	Reset Value
Secondary Regular TTOFF Configuration Register	1A _H	n.a.	00E0 _H

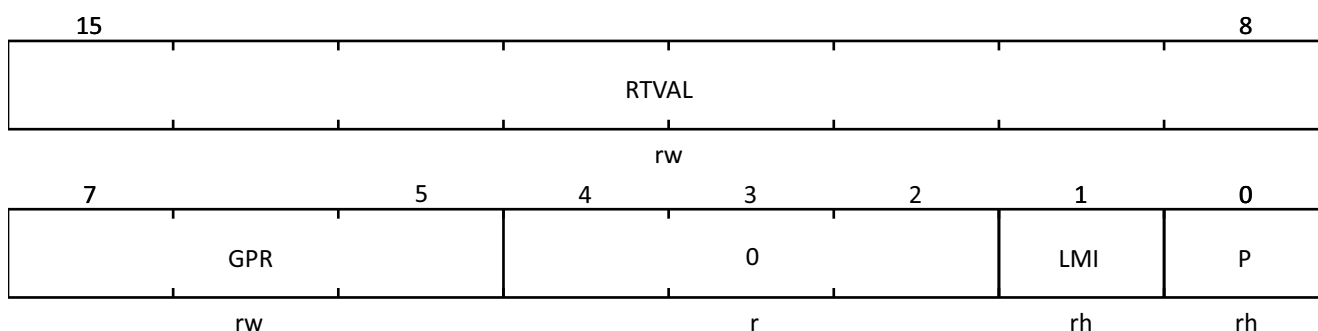

Field	Bits	Type	Description
RTVAL	15:8	rw	<p>Gate Regular TTOFF delay This bit field defines the TTOFF delay for a regular turn-off (in SSOSC2 clock cycles). Writing 00_H to this field deactivates the TTOFF function for regular turn-off. If used, a minimal value of at least 2_H has to be programmed.[formular: value/fclk2; unit:Seconds]</p> <p><i>Note: This bit field is parity protected.</i></p>
GPR	7:5	rw	<p>Gate Regular TTOFF Plateau voltage This bit field defines the TTOFF plateau voltage for regular turn-off sequences. For voltage levels see Table 56.</p> <p><i>Note: This bit field is parity protected.</i></p> <p>0_H gpof0, V_{GPOF0} selected. 1_H gpof1, V_{GPOF1} selected. 2_H gpof2, V_{GPOF2} selected. 3_H gpof3, V_{GPOF3} selected. 4_H gpof4, V_{GPOF4} selected. 5_H gpof5, V_{GPOF5} selected. 6_H gpof6, V_{GPOF6} selected. 7_H gpof7, V_{GPOF7} selected.</p>
0	4:2	r	<p>Reserved Read as 0_B.</p>
LMI	1	rh	<p>Last Message Invalid Notification This bit indicates if the last received SPI Message was correctly processed by the device.</p> <p>0_B , Previous Message was processed correctly. 1_B , Previous Message was discarded.</p>

Register Description

Field	Bits	Type	Description
P	0	rh	Parity Bit Odd Parity Bit.

Register Description

Secondary Safe TTOFF Configuration Register

This register shows the configuration of the TTOFF function for safe turn-off.

SSTTOF	Offset	Wakeup Value	Reset Value
Secondary Safe TTOFF Configuration Register	1B _H	n.a.	2000 _H

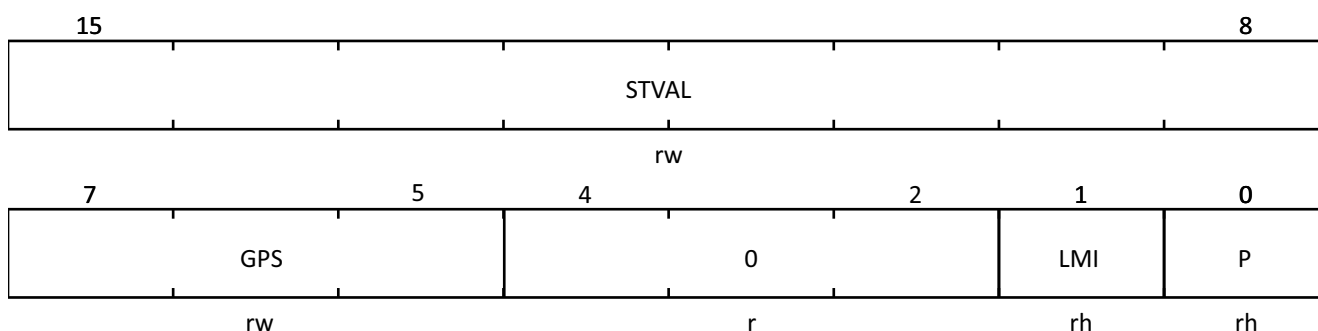

Field	Bits	Type	Description
STVAL	15:8	rw	<p>Gate Safe TTOFF delay</p> <p>This bit field defines the TTOFF delay for a safe turn-off (in OSC2 clock cycles). Writing 00_H to this field deactivates the TTOFF function for safe turn-off. If used, a minimal value of at least 0A_H has to be programmed. [formular: value/fclk2; unit:Seconds]</p> <p>Notes</p> <ol style="list-style-type: none"> In OPM5 and OPM6, it is recommended to have this bit field programmed to 0_H. In OPM4, when safe two level turn off is used, bit field STVAL shall be programmed with a higher value than field SRTTOF.RTVAL. This bit field is parity protected.
GPS	7:5	rw	<p>Gate Safe TTOFF Plateau Voltage</p> <p>This bit field defines the TTOFF plateau voltage for safe turn-off sequences. Coding is identical to SRTTOF.GPR.</p> <p><i>Note:</i> In OPM4, bit field GPS shall be programmed with a value smaller or equal than field SRTTOF.GPR. This bit field is parity protected.</p>
0	4:2	r	<p>Reserved</p> <p>Read as 0_B.</p>
LMI	1	rh	<p>Last Message Invalid Notification</p> <p>This bit indicates if the last received SPI Message was correctly processed by the device.</p> <p>0_B , Previous Message was processed correctly. 1_B , Previous Message was discarded.</p>

Register Description

Field	Bits	Type	Description
P	0	rh	Parity Bit Odd Parity Bit.

Register Description

Secondary **DACLP** Activation Configuration Register

This register defines the activation time of signal **DACLP**.

SACLT	Offset	Wakeup Value	Reset Value
Secondary Active Clamping Configuration Register	1E _H	n.a.	2600 _H

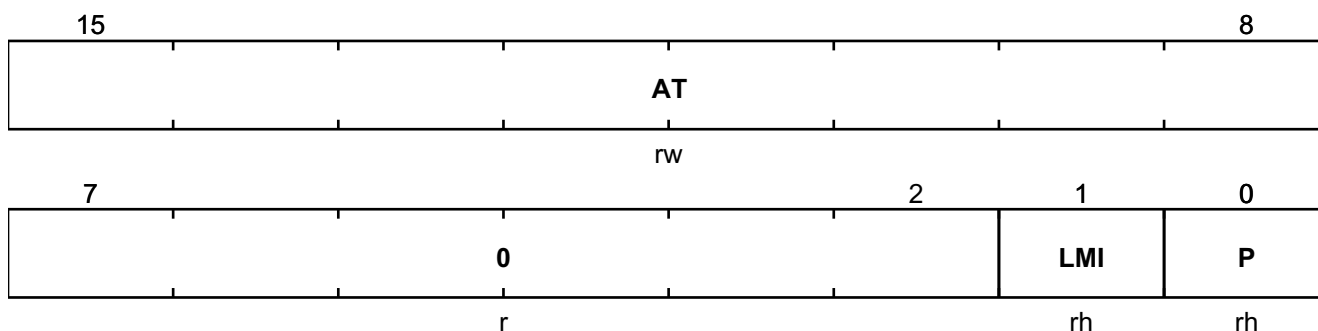

Field	Bits	Type	Description
AT	15:8	rw	<p>Activation time This bit field defines the activation time for signal DACLP (In OSC2 clock cycles) in the range from 0A_H to FE_H [formular: value/fclk2; unit:Seconds]. The range from 01_H...09_H is reserved. During regular off a additional delay of max. 235ns is added to the formular.</p> <p><i>Note: This bit field is parity protected.</i></p> <p>00_H high, The signal DACLP is constant high. FF_H low, The signal DACLP is constant low.</p>
0	7:2	r	<p>Reserved Read as 0_B.</p>
LMI	1	rh	<p>Last Message Invalid Notification This bit indicates if the last received SPI Message was correctly processed by the device. 0_B , Previous Message was processed correctly. 1_B , Previous Message was discarded.</p>
P	0	rh	<p>Parity Bit Odd Parity Bit.</p>

Register Description

Secondary Clock Supervision Register

This register is for internal purpose only.

SCS	Offset	Wakeup Value	Reset Value
Secondary Clock Supervision Register	1F _H	n.a.	0001 _H

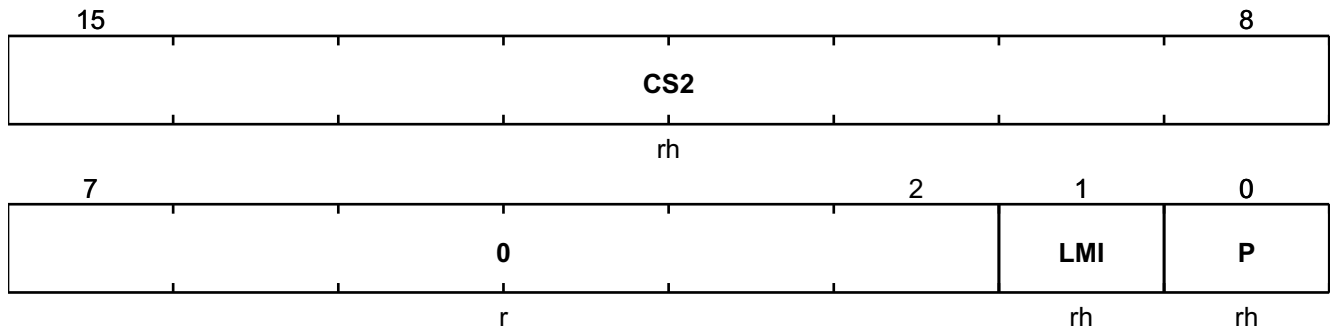

Field	Bits	Type	Description
CS2	15:8	rh	Secondary Clock Supervision This bit field is written by hardware by the TCF function and gives the number of measured Start Stop Oscillator clock cycles. [formular: value/fclk2; unit:Seconds]
0	7:2	r	Reserved Read as 0 _B .
LMI	1	rh	Last Message Invalid Notification This bit indicates if the last received SPI Message was correctly processed by the device. 0 _B , Previous Message was processed correctly. 1 _B , Previous Message was discarded.
P	0	rh	Parity Bit Odd Parity Bit.

Register Description

4.3 Read / Write Address Ranges

Table 37 summarizes which register is accessible with a READ command for a given operating mode.

Table 37 Read Access Validity

	OPM0/1	OPM2	OPM3	OPM4	OPM5	OPM6
PID	X	X	X	X	X	X
PSTAT	X	X	X	X	X	X
PSTAT2	X	X	X	X	X	X
PER	X	X	X	X	X	X
PCFG	X	X	X	X	X	X
PCTRL	X	X	X	X	X	X
PCTRL2	X	X	X	X	X	X
PSCR	X	X	X	X	X	X
PRW	X	X	X	X	X	X
PPIN	X	X	X	X	X	X
PCS	X	X	X	X	X	X
SID	X	X	X	X ¹⁾	X	X ¹⁾
SSTAT	X	X	X	X ¹⁾	X	X ¹⁾
SSTAT2	X	X	X	X ¹⁾	X	X ¹⁾
SER	X	X	X	X ¹⁾	X	X ¹⁾
SCFG	X	X	X	X ¹⁾	X	X ¹⁾
SDESAT1	X	X	X	X ¹⁾	X	X ¹⁾
SCTRL	X	X	X	X ¹⁾	X	X ¹⁾
SSCR	X	X	X	X ¹⁾	X	X ¹⁾
SDESAT0	X	X	X	X ¹⁾	X	X ¹⁾
SOCP	X	X	X	X ¹⁾	X	X ¹⁾
SRTTOF	X	X	X	X ¹⁾	X	X ¹⁾
SSTTOF	X	X	X	X ¹⁾	X	X ¹⁾
SACLT	X	X	X	X ¹⁾	X	X ¹⁾
SCS	X	X	X	X ¹⁾	X	X ¹⁾

1) Increased latency time

Register Description

Table 38 summarizes which register is accessible with a WRITEL command for a given operating mode.

Table 38 Write Access Validity

	OPM0/1	OPM2	OPM3	OPM4	OPM5	OPM6
PID						
PSTAT						
PSTAT2						
PER						
PCFG		X				
PCTRL	X	X	X	X	X	X
PCTRL2	X	X	X	X	X	X
PSCR		X				
PRW	X	X	X	X	X	X
PPIN						
PCS						
SID						
SSTAT						
SSTAT2						
SER						
SCFG		X				
SDESAT1		X				
SCTRL						
SSCR		X				
SDESAT0		X				
SOCP		X				
SRTTOF		X				
SSTTOF		X				
SACLT		X				
SCS						

Specification

5 Specification

5.1 Typical Application Circuit

Table 39 Component Values

Parameter	Symbol	Values			Unit	Note or Test Condition
		Min.	Typ.	Max.		
Decoupling Capacitance (Between VEE2 and GND2)	C_d	2 x 0.5	11	-	μF	10 μF capacitance next to the power supply source (e.g. flyback converter). 1 μF close to the device. It is strongly recommended to have at least two capacitances close to the device (e.g. 2 x 500nF).
Decoupling Capacitance (Between VCC2 and GND2)	C_d	-	11	-	μF	10 μF capacitance next to the power supply source (e.g. flyback converter). 1 μF close to the device.
Decoupling Capacitance (Between VCC1 and GND1)	C_d	-	11	-	μF	10 μF capacitance next to the power supply source (e.g. flyback converter). 1 μF close to the device.
Series Resistance	R_{s1}	0	1	-	$\text{k}\Omega$	
Pull-up Resistance	R_{pu1}	1	10	-	$\text{k}\Omega$	
Filter Resistance	R_1	0	1	-	$\text{k}\Omega$	Value must be fit to application environment.
Filter Capacitance	C_1	0	47	-	pF	Value must be fit to application environment.
Reference Resistance on primary	R_{ref1}	24	24.9	25.8	$\text{k}\Omega$	As close as possible to the device.
Reference Capacitance on primary	C_{ref1}	70	100	300	pF	As close as possible to the device.
Pull-up Resistance	R_{pu2}	1	10	-	$\text{k}\Omega$	
Reference Resistance on secondary	R_{ref2}	21.3	22.1	22.9	$\text{k}\Omega$	As close as possible to the device.
Reference Capacitance on secondary	C_{ref2}	70	100	300	pF	As close as possible to the device.
DESAT filter Resistance	R_{desat}	1	3	-	$\text{k}\Omega$	Depends on required response time.
DESAT filter Capacitance	C_{desat}	-	n/a	-	pF	Depends on required response time.
DESAT Diode	D_{desat}	-	n/a	-	-	HV diode.
OSD Filter Resistance	R_{osd}	-	1	-	$\text{k}\Omega$	

Specification

Table 39 Component Values (cont'd)

Parameter	Symbol	Values			Unit	Note or Test Condition
		Min.	Typ.	Max.		
OSD Filter Capacitance	C_{osd}	-	47	-	pF	
Sense Resistance	R_{sense}	-	n/a	-	Ω	Depends on IGBT specification.
OCP filter Resistance	R_{ocp}	-	n/a	-	Ω	Depends on required response time.
OCP filter Capacitance	C_{ocp}	-	n/a	-	nF	Depends on required response time.
OCPG resistance	R_{ocpg}	0	-	100	Ω	
NUV2 Filter Resistance	R_2	-	n/a	-	Ω	Depends on required response time.
NUV2 Filter Capacitance	C_2	-	-	100	pF	
Active Clamping Resistance	R_{acl1}	-	n/a	-	Ω	Depends on application requirements
Active Clamping Resistance	R_{acl2}	-	n/a	-	k Ω	Depends on application requirements
Active Clamping Capacitance	C_{acli}	-	n/a	-	nF	Depends on application requirements
TVS Diode	$D_{tvsac1},$ D_{tvsac2}	-	n/a	-	-	Depends on application requirements
Active Clamping Diode	D_{acl}	-	n/a	-	-	Depends on application requirements
ACLI Clamping Diode	D_{acl2}	-	n/a	-	-	Depends on application requirements
VREG Capacitance	C_{vreg}	0.5	1	2	μ F	As close as possible to the device.
GATE Resistance	R_{gon}	0.5	-	-	Ω	
GATE Resistance	R_{goff}	0.5	-	-	Ω	
GATE Clamping Diode	D_{gcl1}	-	n/a	-	-	¹⁾
GATE Clamping Diode	D_{gcl2}	-	n/a	-	-	E.g. Schottky Diode. ¹⁾
GATE Series Resistance	R_{gate}	0	10	-	Ω	Optional component.
VEE2 Clamping Diode	D_{gcl3}	-	n/a	-	-	E.g. Schottky Diode. ¹⁾

1) Characteristics of this components are application specific.

Specification

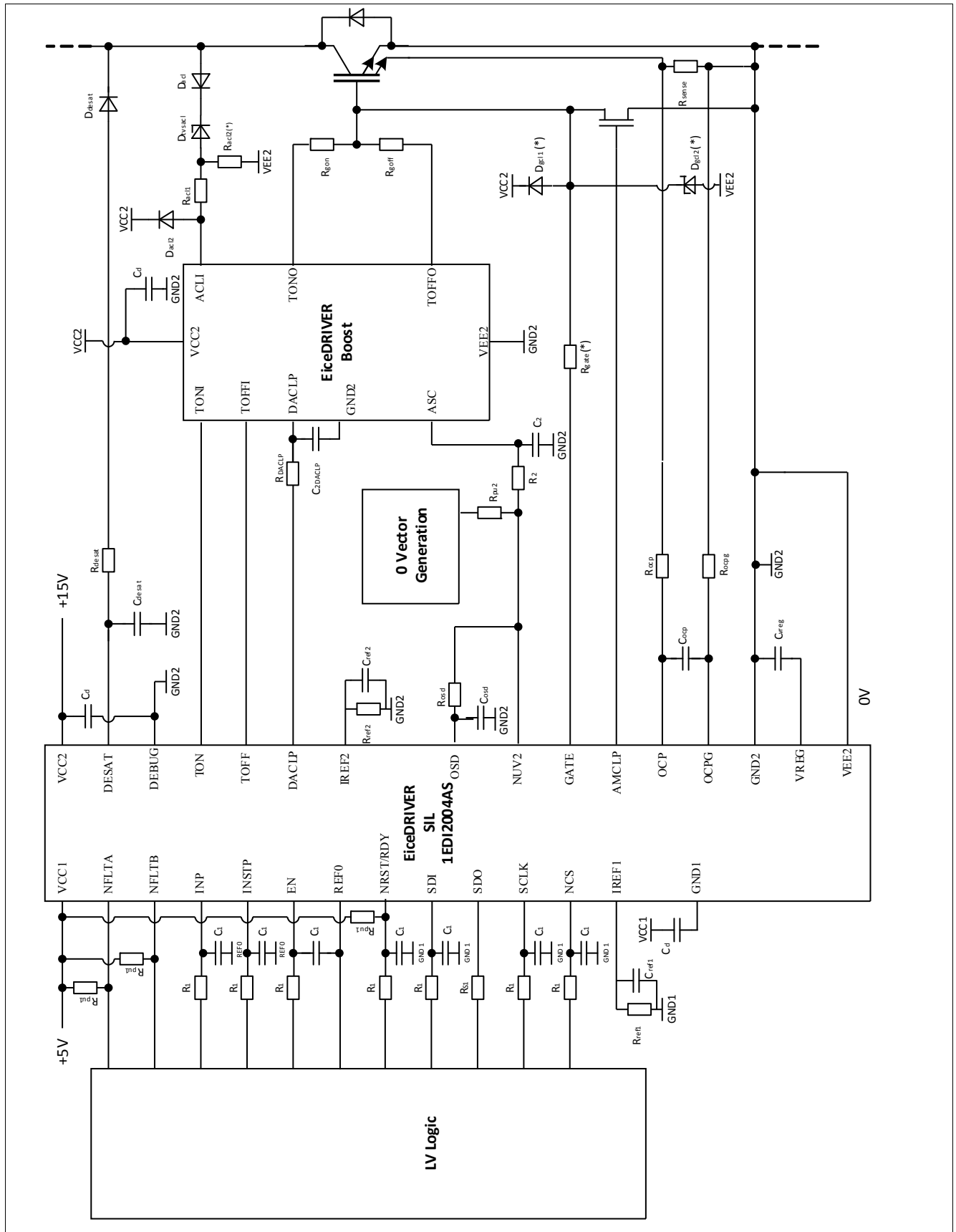

Figure 25 Typical Application Example

Note: Components marked with (*) are optional.

Specification

5.2 Absolute Maximum Ratings

Stress above the maximum values listed here may cause permanent damage to the device. Exposure to absolute maximum rating conditions for extended periods may affect device reliability.

Table 40 Absolute Maximum Ratings¹⁾

Parameter	Symbol	Values			Unit	Note or Test Condition
		Min.	Typ.	Max.		
Junction temperature	T_{JUNC}	-40	-	150	°C	
Storage temperature	T_{STO}	-55	-	150	°C	
Positive power supply (primary)	V_{CC1MAX}	-0.3	-	6.0	V	Referenced to GND1
Positive power supply (secondary)	V_{CC2MAX}	-0.3	-	28	V	Referenced to GND2
Negative power supply	V_{EE2MAX}	-13	-	0.3	V	Referenced to GND2
Power supply voltage difference (secondary) $V_{CC2}-V_{EE2}$	V_{DS2}	-	-	40	V	
Voltage on any I/O pin on prim. side except INP , INSTP , EN	V_{IN1}	-0.3	-	6.0	V	Referenced to GND1
Voltage on INP , INSTP , EN pins	V_{INR1}	-0.3	-	6.0	V	Referenced to REF0 ²⁾
Voltage difference between REF0 and GND1	V_{DG1}	-4	-	4	V	
Voltage difference between OCPG and GND2	V_{OCPG2}	-0.3	-	0.3	V	
TON & TOFF Source / Sink Peak Current	$I_{1502MAX}$	-	-	2.7	A	$V_{CC2}=18V$, $V_{EE2}=-10V$, max. pulse $t_{MAX} = 3.5\mu s$
Output current on push-pull I/O on primary side	I_{OUTPP1}	-	-	20	mA	
Output current on push-pull I/O on secondary side	I_{OUTPP2}	-	-	20	mA	
Output current on open drain I/O on primary side	I_{OUTOD1}	-	-	20	mA	
Output current on open drain I/O on secondary side	I_{OUTOD2}	-	-	10	mA	
Voltage on 5 V pin on secondary side.	V_{IN52}	-0.3	-	6.0	V	Referenced to GND2
Voltage on 15 V pin on secondary side.	V_{IN152}	$V_{EE2}-0.3$	-	$V_{CC2}+0.3$	V	Referenced to GND2 , except DESAT
Voltage on DESAT pin.	$V_{INDESAT}$	-0.3	-	20	V	Referenced to GND2
ESD Immunity	V_{ESD}	-	-	2	kV	HBM ³⁾
		-	-	750	V	CDM ⁴⁾ , pins 1, 16, 17, 36
		-	-	500	V	CDM ⁴⁾ , all other pins
MSL Level	MSL	n.a.	3	n.a.		

1) Not subject to production test. Absolute maximum Ratings are verified by design / characterization.

2) Max. voltage of $V_{INR1}+V_{DG1}$ should be below 7V.

3) According to EIA/JESD22-A114-B.

4) According to JESD22-C101-C.

Specification

5.3 Operating range

The following operating conditions must not be exceeded in order to ensure correct operation of the 1EDI2004AS. All parameters specified in the following sections refer to these operating conditions, unless otherwise noticed.

Table 41 Operating Conditions

Parameter	Symbol	Values			Unit	Note or Test Condition
		Min.	Typ.	Max.		
Junction temperature	T _{JUNC}	-40	-	150	°C	
Positive power supply (primary)	V _{CC1}	4.65	5.0	5.5	V	Referenced to GND1 ¹⁾
Positive power supply (secondary)	V _{CC2}	13.5	16.5	18.0	V	Referenced to GND2 ²⁾
Negative power supply	V _{EE2}	-10.0	-4.0	0.3	V	Referenced to GND2
PWM switching frequency	f _{sw}	-	-	30	kHz	³⁾
Common Mode Transient Immunity	dV _{ISO} /dt	-50	-	50	kV/μs	At 500 V ⁴⁾

- 1) Deterministic and correct operation of the device is ensured down to V_{UVLO1L}.
- 2) Deterministic and correct operation of the device is ensured down to V_{UVLO2L} and up to 28V.
- 3) Maximum junction temperature of the device must not be exceeded.
- 4) Not subject to production test. This parameter is verified by design / characterization.

5.4 Thermal Characteristics

The indicated thermal parameters apply to the full operating range, unless otherwise specified.

Table 42 Thermal Characteristics

Parameter	Symbol	Values			Unit	Note or Test Condition
		Min.	Typ.	Max.		
Thermal Resistance Junction to Ambient	R _{THJA}	-	60	-	K/W	T _{amb} =25°C ¹⁾²⁾
Thermal Resistance Junction to Case (bottom)	R _{THJCBOT}	-	-	41	K/W	T _{amb} =25°C ¹⁾³⁾
Thermal Resistance Junction to Case (top)	R _{THJCTOP}	-	-	36	K/W	T _{amb} =25°C ¹⁾⁴⁾
Ψ - Pseudo Thermal Resistance Junction to Case (top)	R _{PSIJT}	-	-	3	K/W	T _{amb} =25°C ¹⁾⁵⁾

- 1) Not subject to production test. This parameter is verified by design / characterization.
- 2) Specified R_{THJA} value is according to JESD51-2 at natural convection on JEDEC 2s2p board in JESD51-2 box.
- 3) Specified R_{THJCBOT} value is according to JESD51-14 with temperature controlled heat-sink at case bottom without any board [T_J = R_{THJCBOT} × (P_{DIS1} + P_{DIS2}) + T_{amb}].
- 4) Specified R_{THJCTOP} value is according to JESD51-14 with temperature controlled heat-sink at case top without any board [T_J = R_{THJCTOP} × (P_{DIS1} + P_{DIS2}) + T_{amb}].
- 5) Specified R_{PSIJT} value is according to JESD51-2 at natural convection on JEDEC 2s2p board in JESD51-2 box. [T_J = R_{PSIJT} × (P_{DIS1} + P_{DIS2}) + T_{TOP}].

Specification

5.5 Electrical Characteristics

The indicated electrical parameters apply to the full operating range, unless otherwise specified.

5.5.1 Power Supply

Table 43 Power Supplies Characteristics

Parameter	Symbol	Values			Unit	Note or Test Condition
		Min.	Typ.	Max.		
UVLO1 Threshold High	V_{UVLO1H}	4.20	4.45	4.65	V	Referenced to GND1
UVLO1 Threshold Low	V_{UVLO1L}	4.15	4.40	4.60	V	Referenced to GND1
UVLO1 Hysteresis	$V_{UVLO1HYS}$	40	70	100	mV	
UVLO1 Detection Time	t_{UVLO1D}	-	1.3	1.9	μ s	slew rate 10V/ μ s, overdrive +/-325mV ¹⁾
UVLO2 Threshold High	V_{UVLO2H}	11.5	12.5	13.0	V	Referenced to GND2
UVLO2 Threshold Low	V_{UVLO2L}	11.0	11.7	12.5	V	Referenced to GND2
UVLO2 Hysteresis	$V_{UVLO2HYS}$	500	850	-	mV	
UVLO2 Detection Time	t_{UVLO2D}	-	-	100	ns	slew rate 10V/ μ s, overdrive +/-800mV ¹⁾
OVLO2 Threshold	V_{OVLO2}	18.5	19.2	20	V	Referenced to GND2
OVLO2 Detection Time	t_{OVLO2D}	-	-	130	ns	slew rate 10V/ μ s, overdrive +/-800mV ¹⁾
UVLO3 Threshold	V_{UVLO3}	- 11.55	-11.0	-10.4	V	Referenced to GND2
UVLO3 Detection Time	t_{UVLO3D}	-	-	150	ns	slew rate 10V/ μ s, overdrive +/-500mV ¹⁾
OVLO3 Threshold	V_{OVLO3}	-3.5	-2.5	-1.5	V	Referenced to GND2
OVLO3 Detection Time	t_{OVLO3D}	-	-	130	ns	slew rate 10V/ μ s, overdrive +/-1100mV ¹⁾
V_{CC2} Reset Level	V_{RST2}	7.9	8.3	8.8	V	Referenced to GND2
VCC1 ramp-up / down slew rate	$ t_{RP1} $	-	-	0.5	V/ms	Absolute value
VCC2 ramp-up / down slew rate	$ t_{RP2} $	-	-	1.5	V/ms	Absolute value
VEE2 ramp-up / down slew rate	$ t_{RP3} $	-	-	0.8	V/ms	Absolute value
Quiescent Current Input Chip	I_{Q1}	-	8	10	mA	$V_{CC1}=5.5V$, all I/Os inactive, OPM0
Quiescent Current Output Chip (VCC2)	I_{QVCC2}	6.5	13	16	mA	$V_{CC2}=18V$, $V_{EE2}=-10V$, all I/Os inactive, OPM0
Quiescent Current Output Chip (VEE2)	I_{QVEE2}	-5	-	-	mA	$V_{CC2}=18V$, $V_{EE2}=-10V$, all I/Os inactive, OPM0

Specification

Table 43 Power Supplies Characteristics (cont'd)

Parameter	Symbol	Values			Unit	Note or Test Condition
		Min.	Typ.	Max.		
Input Current deviation of Output Chip (VCC2 - VEE2)	$ I_{VCC2} - I_{VEE2} $	6	-	12	mA	$V_{CC2}=13.5V, V_{EE2}=0V$, all I/Os inactive, OPM0, NRST = 0; DESAT, OCP, AMCLP, DACLP, NUV2 floating; $R_{TON}=R_{TOFF}=100\Omega$; $C_{LOAD}=2.2nF$ ¹⁾
		8	-	14	mA	$V_{CC2}=13.5V, V_{EE2}=0V$, all I/Os inactive, all OPM, INP = 0; DESAT, OCP, AMCLP, DACLP, NUV2 floating; $R_{TON}=R_{TOFF}=100\Omega$; $C_{LOAD}=2.2nF$ ¹⁾
		9	-	15.5	mA	$V_{CC2}=13.5V, V_{EE2}=0V$, all I/Os inactive, OPM 4, INP = 20kHz; AMCLP, DACLP, NUV2 floating; OCP=GND; DESAT=7V; $R_{TON}=R_{TOFF}=100\Omega$; $C_{LOAD}=2.2nF$ ¹⁾
Power Dissipation - Primary Chip	P_{DIS1}	-	50	-	mW	$T_{AMB}=25^{\circ}C, V_{CC1} = \text{typ.}$, all I/Os inactive, OPM0 ¹⁾
Power Dissipation - Secondary Chip	P_{DIS2}	-	250	-	mW	$T_{AMB}=25^{\circ}C, V_{CC2} = \text{typ.}$, $V_{EE2} = \text{typ.}$, all I/Os inactive, OPM0 ¹⁾

1) Not subject to production test. This parameter is verified by design / characterization.

5.5.2 Internal Oscillators

Table 44 Internal Oscillators

Parameter	Symbol	Values			Unit	Note or Test Condition
		Min.	Typ.	Max.		
Primary main oscillator frequency	f_{clk1}	14.8	17.8	20.8	MHz	with Reference Resistance on primary R_{ref1} @ pin IREF1 ¹⁾
Secondary main oscillator / Start-Stop Oscillator Frequency	f_{clk2}, f_{clkst2}	15.0	17.5	20.0	MHz	with Reference Resistance on secondary R_{ref2} @ pin IREF2 ¹⁾

1) An exceeding of given resistance can result in failure events (see [Table 14 "Failure Events Summary" on Page 48](#)).

Specification

5.5.3 Primary I/O Electrical Characteristics

Table 45 Electrical Characteristics for Pins: **INP, INSTP, EN**

Parameter	Symbol	Values			Unit	Note or Test Condition
		Min.	Typ.	Max.		
Low Input Voltage	V_{INPRL1}	0	-	$0.3 \times V_{CC1}$	V	Referenced to REF0
High Input Voltage	V_{INPRH1}	$0.7 \times V_{CC1}$	-	V_{CC1}	V	Referenced to REF0
Weak pull down resistance INP, INSTP, EN	R_{PDIN1}	20	45	100	k Ω	To REF0
Weak pull up resistance INP, INSTP, EN	R_{PUIN1}	150	250	450	k Ω	To VCC1
INP, INSTP, EN Input Leakage Current	$ I_{INLEAK1} $	-	<1	10	μ A	additional to R_{PUIN1} & R_{PDIN1} ¹⁾
Input Pulse Suppression	t_{INPS1}	-	20	-	ns	¹⁾
Time between EN valid and INP High Level	t_{INPEN}	8	-	-	μ s	See Chapter 2.4.3
INP High / Low Duration	t_{INPPD}	250	-	-	ns	$V_{CC1}=\text{typ.}, V_{CC2}=\text{typ.}, V_{EE2}=\text{typ.}, V_{REG}=\text{typ.}, 50\% \text{ to } 50\%$ ¹⁾
INSTP High / Low Duration	$t_{INSTPPD}$	250	-	-	ns	$V_{CC1}=\text{typ.}, V_{CC2}=\text{typ.}, V_{EE2}=\text{typ.}, V_{REG}=\text{typ.}, 50\% \text{ to } 50\%$ ¹⁾
Duration between EN valid-to-invalid transition and the next invalid-to-valid transition	t_{ENINV}	8	-	-	μ s	¹⁾²⁾

1) Not subject to production test. This parameter is verified by design / characterization.

2) Timing will be extended by TLTOFF settings as well as AMCLDel.

Table 46 Electrical Characteristics for Pins: **SCLK, SDI, NCS**

Parameter	Symbol	Values			Unit	Note or Test Condition
		Min.	Typ.	Max.		
Low Input Voltage	V_{INPL1}	0	-	$0.3 \times V_{CC1}$	V	Referenced to GND1
High Input Voltage	V_{INPH1}	$0.7 \times V_{CC1}$	-	V_{CC1}	V	Referenced to GND1
Weak pull up resistance to SCLK, SDI, NCS	R_{PUSPI1}	26.5	60	120	k Ω	To VCC1 .
SCLK, SDI, NCS Input Leakage Current	$ I_{SPILEAK} $	-	<1	15	μ A	$V_{CC1}=5V; \text{SCLK, SDI, NCS} = V_{CC1}$

Specification

Table 47 Electrical Characteristics for Pins: **NRST/RDY**

Parameter	Symbol	Values			Unit	Note or Test Condition
		Min.	Typ.	Max.		
NRST/RDY Output Voltage in Non-Ready conditions.	V_{OUTNR}	-	0.7	0.9	V	$V_{CC1}=5V, I_{load} = 2\text{ mA}$
		-	0.65	0.85	V	$V_{CC1}=0V, I_{load} = 0.5\text{mA}$
NRST/RDY driven-active time after power supplies are within operating range.	t_{RST}	-	15.4	-	μs	¹⁾
NRST/RDY minimum activation time.	t_{RSTAT}	10	-	-	μs	

1) Not subject to production test. This parameter is verified by design / characterization.

Table 48 Electrical Characteristics for Pins: **SDO**

Parameter	Symbol	Values			Unit	Note or Test Condition
		Min.	Typ.	Max.		
Low Output Voltage	V_{OUTPL1}	-	-	0.5	V	$I_{load} = 5\text{mA}$
High Output Voltage	V_{OUTPH1}	3.85	-	-	V	$I_{load} = 5\text{mA}$

Table 49 Electrical Characteristics for Pins: **NFLTA, NFLTB**

Parameter	Symbol	Values			Unit	Note or Test Condition
		Min.	Typ.	Max.		
Low Output Voltage	V_{OUTDL1}	-	-	0.5	V	$I_{SINK}=5\text{mA}$

Specification

5.5.4 Secondary I/O Electrical Characteristics

Table 50 Electrical Characteristics for Pins: **TON**, **TOFF** & **GATE**

Parameter	Symbol	Values			Unit	Note or Test Condition
		Min.	Typ.	Max.		
TON & TOFF Output Voltage High	V _{15OH2}	V _{CC2} -1	-	V _{CC2}	V	Referenced to GND2
		V _{CC2} -0.01	-	V _{CC2}	V	Referenced to GND2 , no load ¹⁾
TON & TOFF Output Voltage Low	V _{15OL2}	V _{EE2} +1	-	V _{EE2MAX}	V	Referenced to GND2
		V _{EE2} +0.01	-	V _{EE2MAX}	V	Referenced to GND2 , no load ¹⁾
TON & TOFF Source / Sink Peak Current	I _{15O2}	1	-	-	A	¹⁾²⁾
GATE Input voltage range	V _{15GATE}	V _{EE2}	-	V _{CC2}	V	Referenced to GND2 ²⁾
Passive Clamping Voltage	V _{PCLP1}	-	-	V _{EE2} +1	V	Secondary chip not supplied, TON , TOFF & GATE shorted, I _{CLAMP} =10 mA.
	V _{PCLP2}	-	V _{EE2} +1	-	V	Secondary chip not supplied, TON , TOFF & GATE shorted, I _{CLAMP} =100 mA. ¹⁾

1) Not subject to production test. This parameter is verified by design / characterization.

2) thermally limited (Need to be verified in application.)

Table 51 Electrical Characteristics for Pins: **OSD**, **DEBUG**

Parameter	Symbol	Values			Unit	Note or Test Condition
		Min.	Typ.	Max.		
Low Input Voltage	V _{5INL2}	0	-	1.5	V	Referenced to GND2
High Input Voltage	V _{5INH2}	3.5	-	5.5	V	Referenced to GND2
Weak pull down on DEBUG	R _{PDIN2}	40	100	175	kΩ	To GND2 .
Weak pull down on OSD	R _{PDOSD2}	60	100	175	kΩ	To GND2

Table 52 Electrical Characteristics for Pin: **NUV2**

Parameter	Symbol	Values			Unit	Note or Test Condition
		Min.	Typ.	Max.		
Low Output Voltage	V _{OUTDL2}	0	-	0.5	V	I _{SINK} =5mA, Referenced to GND2

Specification

Table 53 Electrical Characteristics for Pins: **DACLP**

Parameter	Symbol	Values			Unit	Note or Test Condition
		Min.	Typ.	Max.		
Output Voltage High	V _{50H2}	V _{REG2} ⁻¹	-	V _{REG2}	V	Referenced to GND2 , I _{LOAD} = 6mA, rms value ²⁾
		V _{REG2MIN} - 0.005	-	V _{REG2MAX}	V	Referenced to GND2 , no load, rms value ¹⁾²⁾
Output Voltage Low	V _{50L2}	V _{GND2}	-	0.5	V	Referenced to GND2 , I _{LOAD} = 6mA, V _{REG} = typ., rms value ²⁾
		V _{GND2}	-	0.005	V	Referenced to GND2 , no load, V _{REG} = typ., rms value ¹⁾²⁾
Output Rise Time	t _{riseDACLP}	-	100	150	ns	V _{CC1} = typ., V _{CC2} = typ., V _{EE2} = typ., C _{LOAD} = 1.5nF, 10%-90% ²⁾
Output Fall Time	t _{fallDACLP}	-	100	200	ns	V _{CC1} = typ., V _{CC2} = typ., V _{EE2} = typ., C _{LOAD} = 1.5nF, 90%-10% ²⁾
		-	100	150	ns	V _{CC1} = typ., V _{CC2} = typ., V _{EE2} = typ., C _{LOAD} = 1nF, 90%-10% ¹⁾²⁾
		-	100	150	ns	V _{CC1} = typ., V _{CC2} = typ., V _{EE2} = typ., C _{LOAD} = 1.5nF, 80%-20% ¹⁾²⁾

1) Not subject to production test. This parameter is verified by design / characterization.

2) Thermally limited (Need to be verified in application.)

Table 54 Electrical Characteristics for Pins: **AMCLP**

Parameter	Symbol	Values			Unit	Note or Test Condition
		Min.	Typ.	Max.		
Output Voltage High	V _{AMOH2}	V _{REG2} ⁻¹	-	V _{REG2}	V	Referenced to GND2 , I _{LOAD} = 6mA, V _{REG} = typ., rms value ¹⁾
		V _{REG2MIN} - 0.005	-	V _{REG2MAX}	V	Referenced to GND2 , no load, rms value ²⁾
Output Voltage Low	V _{AMOL2}	V _{GND2}	-	0.5	V	Referenced to GND2 , I _{LOAD} = 6mA, V _{REG} = typ., rms value ¹⁾
		V _{GND2}	-	0.005	V	Referenced to GND2 , no load, rms value ¹⁾²⁾
Output Rise Time	t _{riseAMCLP}	-	100	150	ns	V _{CC1} = typ., V _{CC2} = typ., V _{EE2} = typ., C _{LOAD} = 1.5nF, 10%-90% ¹⁾

Specification

Table 54 Electrical Characteristics for Pins: **AMCLP** (cont'd)

Parameter	Symbol	Values			Unit	Note or Test Condition
		Min.	Typ.	Max.		
Output Fall Time	$t_{fallAMCLP}$	-	100	200	ns	$V_{CC1}=typ., V_{CC2}=typ., V_{EE2}=typ., C_{LOAD} = 1.5nF, 90\%-10\%$ ¹⁾
		-	100	150	ns	$V_{CC1}=typ., V_{CC2}=typ., V_{EE2}=typ., C_{LOAD} = 1.5nF, 80\%-20\%$ ¹⁾²⁾
		-	100	150	ns	$V_{CC1}=typ., V_{CC2}=typ., V_{EE2}=typ., C_{LOAD} = 1nF, 90\%-10\%$ ¹⁾²⁾
Delay from OSD event detection to AMCLP turn off activation	$t_{OSDAMCLPD}$	-	40	85	ns	$V_{CC1}=typ., V_{CC2}=typ., V_{EE2}=typ.,$ No load, OSD rising edge at 90% of V_{REG} and AMCLP falling edge at 90% of V_{REG} ²⁾
Delay from Gate below V_{GATE1L} detection to turn on activation	$t_{AMCOFFDel}$	-	80	140	ns	$V_{CC1}=typ., V_{CC2}=typ., V_{EE2}=typ.,$ No load, $V_{GATE1L} = 2.1V,$ falling edge and AMCLP rising edge 10% of $V_{REG},$ $T_{JUNC}=150^{\circ}C$ ²⁾

1) thermally limited (Need to be verified in application.)

2) Not subject to production test. This parameter is verified by design / characterization.

Table 55 Electrical Characteristics for Pin: **VREG**

Parameter	Symbol	Values			Unit	Note or Test Condition
		Min.	Typ.	Max.		
VREG output voltage range	V_{REG2}	4.75	5	5.30	V	Referenced to GND2 , $C_{LOAD}=1\mu F$
VREG output DC current	I_{REG2}	-	-	525	μA	¹⁾

1) Not subject to production test. This parameter is verified by design / characterization.

Specification

5.5.5 Switching Characteristics

Table 56 Switching Characteristics

Parameter	Symbol	Values			Unit	Note or Test Condition
		Min.	Typ.	Max.		
Input to Output Propagation Delay ON	t_{PDON}	175	215	255	ns	$V_{CC1}=typ., V_{CC2}=typ., V_{EE2}=typ.,$ Start: INP rising edge at 90% of V_{CC1} (Typ.), Stop: GATE rising edge at 10% of V_{CC2} (Typ.), No load, No Gate resistance ¹⁾
Input to Output Propagation Delay OFF	t_{PDOFF}	175	215	255	ns	$V_{CC1}=typ., V_{CC2}=typ., V_{EE2}=typ.,$ Start: INP falling edge at 10% of V_{CC1} (Typ.), Stop: GATE falling edge at 90% of V_{CC2} (Typ.), No load, No Gate resistance ²⁾
Input to Output Propagation Delay Distortion ($t_{PDOFF}-t_{PDON}$)	t_{PDISTO}	-20	0	40	ns	$V_{CC1}=typ., V_{CC2}=typ., V_{EE2}=typ.$
Input to Output Propagation Delay Distortion Variation for two consecutive pulses	$t_{PDISTOV}$	-	25	-	ns	$V_{CC1}=typ., V_{CC2}=typ., V_{EE2}=typ.,$ $T_{JUNC}=25^{\circ}C$ ³⁾
Rise Time	t_{RISE}	-	120	205	ns	$V_{CC1}=typ., V_{CC2}=typ., V_{EE2}=typ.,$ $C_{LOAD} = 10nF, 10\%-90\%$
		-	30	50	ns	$V_{CC1}=typ., V_{CC2}=typ., V_{EE2}=typ.,$ no Load, 10%-90%
Fall Time	t_{FALL}	-	150	235	ns	$V_{CC1}=typ., V_{CC2}=typ., V_{EE2}=typ.,$ $C_{LOAD} = 10nF, 90\%-10\%$
		-	60	100	ns	$V_{CC1}=typ., V_{CC2}=typ., V_{EE2}=typ.,$ no Load, 90%-10%
TTOFF Plateau level	V_{GPOF0}	5.0	6.0	7.0	V	Referenced to GND2 , measured at pin TON (shorted with TOFF) $V_{CC2}=typ., T_{JUNC}=25^{\circ}C$, no VBE Compensation. ⁴⁾
	V_{GPOF1}	6.0	7.0	8.0	V	
	
	V_{GPOF6}	11.0	12.0	13.0	V	
	V_{GPOF7}	12.0	13.0	14.0	V	
TTOFF Plateau level	V_{GPOF0}	4.3	5.3	6.3	V	Referenced to GND2 , measured at pin TON (shorted with TOFF) $V_{CC2}=typ., T_{JUNC}=25^{\circ}C$, with VBE Compensation. ⁴⁾
	V_{GPOF1}	5.3	6.3	7.3	V	
	
	V_{GPOF6}	10.3	11.3	12.3	V	
	V_{GPOF7}	11.3	12.3	13.3	V	
Variation from configured V_{TTOFF}	dV_{Tm40}	-	40	-	mV	$T_J = -40^{\circ}C$ ³⁾
	dV_{T150}	-	-80	-	mV	$T_J = 150^{\circ}C$ ³⁾
TTOFF decrease rate	t_{SLEW}	-	11	-	V/ μs	$C_{load} = 10nF, V_{CC2}=typ.$
TTOFF delay deviation from nominal value	$t_{DEVTTOFF}$	-100	0	100	ns	For a target time of 2 μs , using the TCF. ³⁾

Specification

Table 56 Switching Characteristics (cont'd)

Parameter	Symbol	Values			Unit	Note or Test Condition
		Min.	Typ.	Max.		
TTOFF (Regular) Plateau Time	t _{TTOFF}	2.0	2.22	2.54	μs	SRTTOF.RTVAL =26 _H , assuming no TCF.
Gate Voltage Threshold 1 (low)	V _{GATE1L}	+1.95	+2.1	+2.25	V	Measured at pin GATE , Referenced to VEE2 , T _J = 150°C, T _{COEF} = 1mV/K ⁵)
Gate Voltage Threshold 1 (high)	V _{GATE1H}	+2.6	+3.0	+3.3	V	Measured at pin GATE , Referenced to VEE2 , T _J = 150°C, T _{COEF} = -2.6mV/K ⁵)
Gate Voltage Threshold 2 (high)	V _{GATE2H}	-3.3	-3.15	-3	V	Measured at pin GATE , Referenced to VCC2 , T _J = 150°C, T _{COEF} = -1mV/K ⁵)
Gate Voltage Threshold 2 (low)	V _{GATE2L}	-4.35	-4.2	-3.5	V	Measured at pin GATE , Referenced to VCC2 , T _J = 150°C, T _{COEF} = 2mV/K ⁵)
Active Clamping Activation Time	t _{ACL}	1.9	2.22	2.7	μs	Default value of bit field SACLT.AT . ⁶⁾
WTO Level	V _{GPON0}	8.0	9.0	10.0	V	Referenced to GND2 , measured at pin TON (shorted with TOFF) VCC2=typ., T _{JUNC} =25°C, no VBE Comp. ⁴⁾
WTO Level	V _{GPON0}	8.7	9.7	10.7	V	Referenced to GND2 , measured at pin TON (shorted with TOFF) VCC2=typ., T _{JUNC} =25°C, with VBE Comp. ⁴⁾

- 1) Valid for single switching events with [SCFG.AMCLD](#) and [SRTTOF.RTVAL](#) set to 0. Other settings will extend the timing for regular turn on/off by configured [SCFG.AMCLD](#) or [SRTTOF.RTVAL](#) value.
- 2) Valid for single switching events with [SCFG.AMCLD](#) set to 0. Other settings will extend the timing for regular turn on/off by configured [SCFG.AMCLD](#) value.
- 3) Not subject to production test. Parameters are verified by design / characterization.
- 4) Preliminary data need to be justified by characterization.
- 5) For other temperatures the temperature coefficient T_{COEF} applies [formula: V = V @ T_{REF} + (T-T_{REF})*T_{COEF}].
- 6) If a following switching sequence occurs during this time the delay will extend.

Specification

5.5.6 Desaturation Protection

Table 57 **DESAT** characteristics

Parameter	Symbol	Values			Unit	Note or Test Condition
		Min.	Typ.	Max.		
DESAT Input voltage range	$V_{15DESAT}$	0	-	V_{CC2}	V	Referenced to GND2 ^{1) 2)}
DESAT Source Current	I_{DESAT}	0	-	2	mA	rms value ²⁾
DESAT Reference Level	V_{DESAT0}	8.4	9	9.4	V	$V_{CC2} = \text{typ.}, V_{EE2} = \text{typ.}$
DESAT Pull-up Resistance	$R_{PUDSAT2}$	19	30	46	k Ω	to VCC2
DESAT Low Voltage	V_{DESATL}	-	200	-	mV	Referenced to GND2 , Desat clamping enabled, $I_{\text{sink}} = 5\text{mA}$. ²⁾
DESAT blanking time deviation from programmed value	$dt_{DESATBL}$	-20	-	+20	%	After transition of the PWM command, assuming a 1 μs programmed blanking time, $f_{\text{clk2}} = \text{typ.}$ ²⁾

1) Pin is robust against negative transient (300mA/500ns).

2) Not subject to production test. This parameter is verified by design / characterization.

5.5.7 Overcurrent Protection

Table 58 **OCP** characteristics

Parameter	Symbol	Values			Unit	Note or Test Condition
		Min.	Typ.	Max.		
OC error detection threshold	V_{OCPD1}	270	300	330	mV	Referenced to OCPG
		282	300	318	mV	Referenced to OCPG , $T_j = 150^\circ\text{C}$
OCP blanking time deviation from programmed value	dt_{OCPBL}	-20	-	+20	%	After transition of the PWM command, assuming a 1 μs programmed blanking time, $f_{\text{clk2}} = \text{typ.}$ ¹⁾
OCP Pull-up Resistance	R_{PUOCP2}	40	100	175	k Ω	to internal 5V reference.

1) Not subject to production test. Parameters are verified by design / characterization.

Specification

5.5.8 Error Detection Timing

Table 59 Error Detection Timing

Parameter	Symbol	Values			Unit	Note or Test Condition
		Min.	Typ.	Max.		
Dead Time for Shoot Through Protection	t_{DEAD}	720	-	1200	ns	
Class A event detection to NFLTA activation	t_{AFLTA}	-	2	5	μ s	
EN (Enable) event detection to turn off sequence activation	t_{OFFCLA}	-	-	400	ns	$V_{TOFF}=V_{CC2} - 1\text{ V}^{1)}$
DESAT event detection to turn off sequence activation	$t_{OFFDESAT2}$	-	-	430	ns	$V_{TOFF}=V_{CC2} - 1\text{ V}$, after blanking time elapsed
OCF event occurrence to turn off sequence activation	$t_{OFFOCP2}$	-	110	130	ns	$V_{TOFF}=V_{CC2} - 1\text{ V}$, after blanking time elapsed
Class B event detection to NFLTB activation	t_{BFLTB}	-	2	5	μ s	
Class B event detection to turn off sequence activation	$t_{OFFCLB2}$	-	-	400	ns	$V_{TOFF}=V_{CC2} - 1\text{ V}^{1)2)}$
Failure or reset event detection on primary to turn off sequence activation	$t_{OFFRES1}$	-	-	255	ns	$V_{TOFF}=V_{CC2} - 1\text{ V}^{1)2)}$
Failure or reset event detection on secondary to turn off sequence activation	$t_{OFFRES2}$	-	-	400	ns	$V_{TOFF}=V_{CC2} - 1\text{ V}^{2)3)}$
Verification Mode time out	t_{VMTO}	-	14.7	-	ms	After a transition from OPM2 to OPM5, SCFG.TOSEN = 0 _B ²⁾³⁾
		-	59	-	ms	After a transition from OPM2 to OPM5, SCFG.TOSEN = 1 _B ²⁾³⁾
Desat ModeChange timeout	t_{DBTO}	-	15	-	ms	2)3)
OVLO2 Mode Change timeout	t_{O2MTO}	-	15	-	ms	2)3)
Life sign error detection time	t_{LS}	-	5	-	μ s	After error condition detected by logic.
Life sign error event detection on secondary to turn off sequence activation	t_{OFFLS}	-	-	430	ns	$V_{TOFF}=V_{CC2} - 1\text{ V}^{2)3)}$

- 1) Valid timing when **SCFG.AMCLD** and **SRTTOF.RTVAL** set to 0. Other settings will extend the timing for regular turn on/off by configured **SCFG.AMCLD** or **SRTTOF.RTVAL** value.
- 2) Verified by design / characterization. Not tested in production.
- 3) Deviation of the secondary clock needs to be considered.

Specification

5.5.9 SPI Interface

Table 60 SPI Interface Characteristics

Parameter	Symbol	Values			Unit	Note or Test Condition
		Min.	Typ.	Max.		
SPI frame size	N_{bit}	N.a.	$N*16$	N.a.	bit	N is the daisy chain length
Baud rate	f_{SCLK}	0.1	-	2.0	MHz	Standard SPI configuration, ¹⁾
		0.1	-	1.8	MHz	Daisy chain configuration, ¹⁾
SCLK duty cycle	D_{SCLK}	45	-	55	%	²⁾
SDI set-up time	t_{SDIsu}	45	-	-	ns	²⁾
SDI hold time	t_{SDIh}	100	-	-	ns	²⁾
NCS lead time	t_{CSlead}	1	-	-	μs	²⁾
NCS trail time	$t_{CStrail}$	1	-	-	μs	²⁾
NCS inactive time	$t_{CSinact}$	10	-	-	μs	²⁾
SDO enable time	t_{SDOen}	-	-	500	ns	$C_{load} = 20pF^{2)}$
SDO disable time	t_{SDOdis}	-	-	1	μs	$C_{load} = 20pF^{2)}$
SDO valid time	t_{SDOv}	10	-	205	ns	$C_{load} = 20pF^{2)}$

1) Low Limit verified by design / characterization. Not tested in production.

2) Verified by design / characterization. Not tested in production.

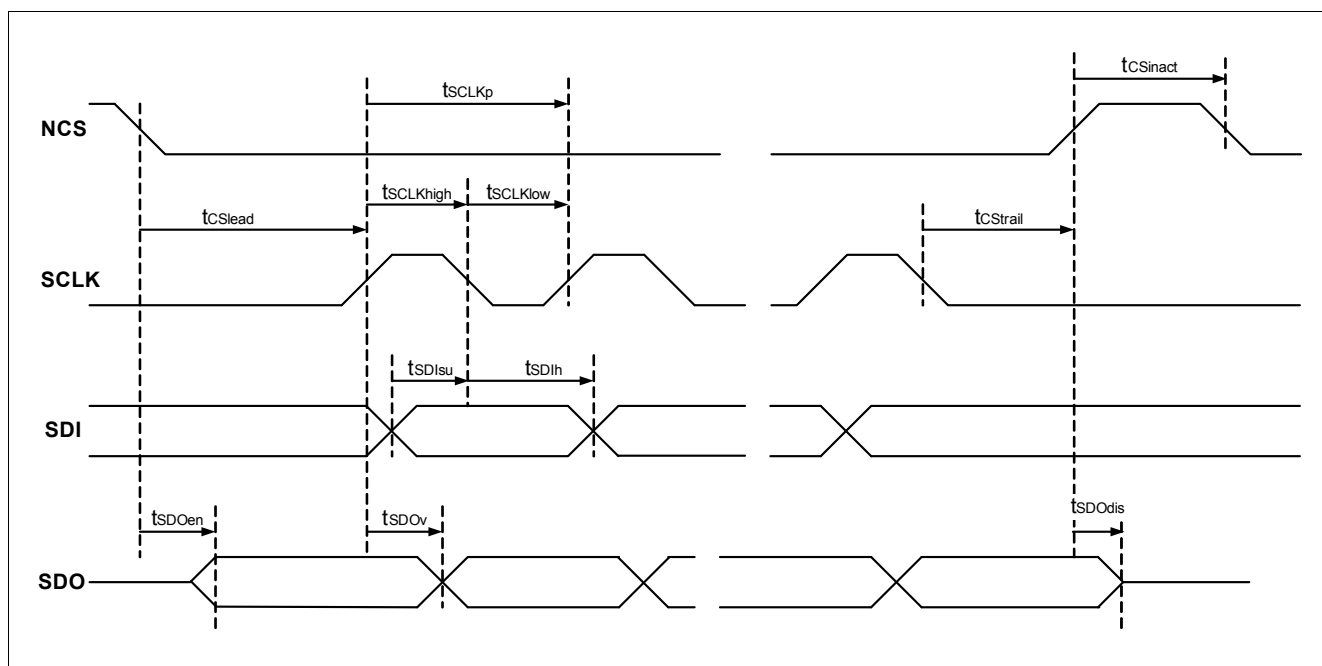

Figure 26 SPI Interface Timing

Specification

5.5.10 Insulation Characteristics

Table 61 Isolation Characteristics referring to DIN EN 60747-5-2 (VDE 0884 - 10):2006-12

Description	Symbol	Characteristic	Unit
Installation classification per EN60664-1, Table 1: rated main voltage less than 150 V _{rms} rated main voltage less than 300 V _{rms} rated main voltage less than 600 V _{rms}		I - IV I - III I - II	
Climatic Classification		40 / 125 / 21	
Pollution Degree (EN 60664-1)		2	
Minimum External Clearance	CLR	8.12	mm
Minimum External Creepage	CPG	8.24	mm
Minimum Comparative Tracking Index	CTI	400	
Maximum Repetitive Insulation Voltage	V _{IORM}	1420	V _{PEAK}
Highest Allowable Overvoltage ¹⁾	V _{IOTM}	6000	V _{PEAK}
Maximum Surge Insulation Voltage	V _{IOSM}	6000	V _{PEAK}

1) Refer to VDE 0884 for a detailed description of Method a and Method b partial discharge

Table 62 Isolation Characteristics referring to UL 1577

Description	Symbol	Characteristic	Unit
Insulation Test Voltage / 1 min	V _{ISO}	3750	V _{rms}
Insulation Test Voltage / 1 sec	V _{ISO}	4500	V _{rms}

6 Package Information

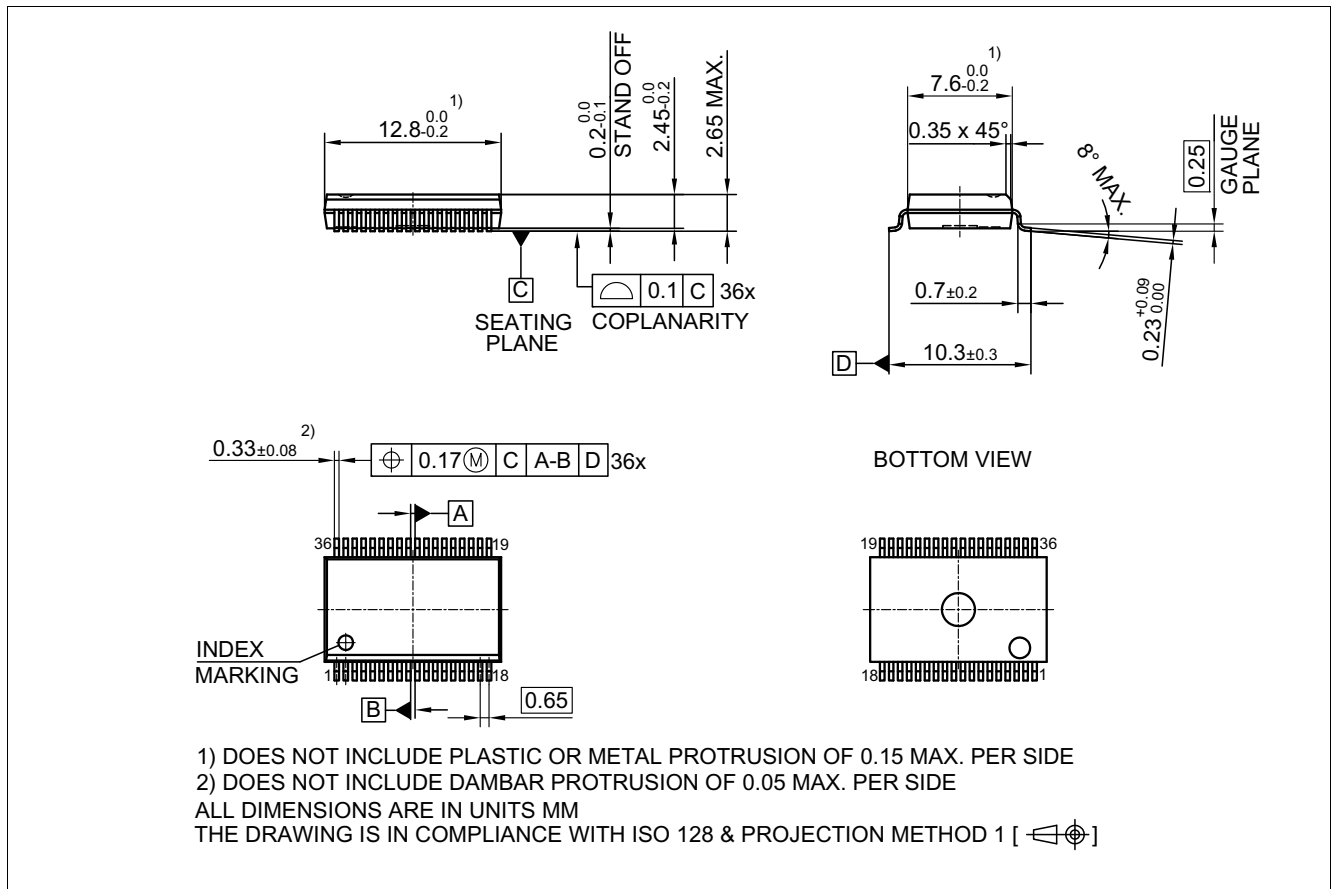

Figure 27 Package Dimensions

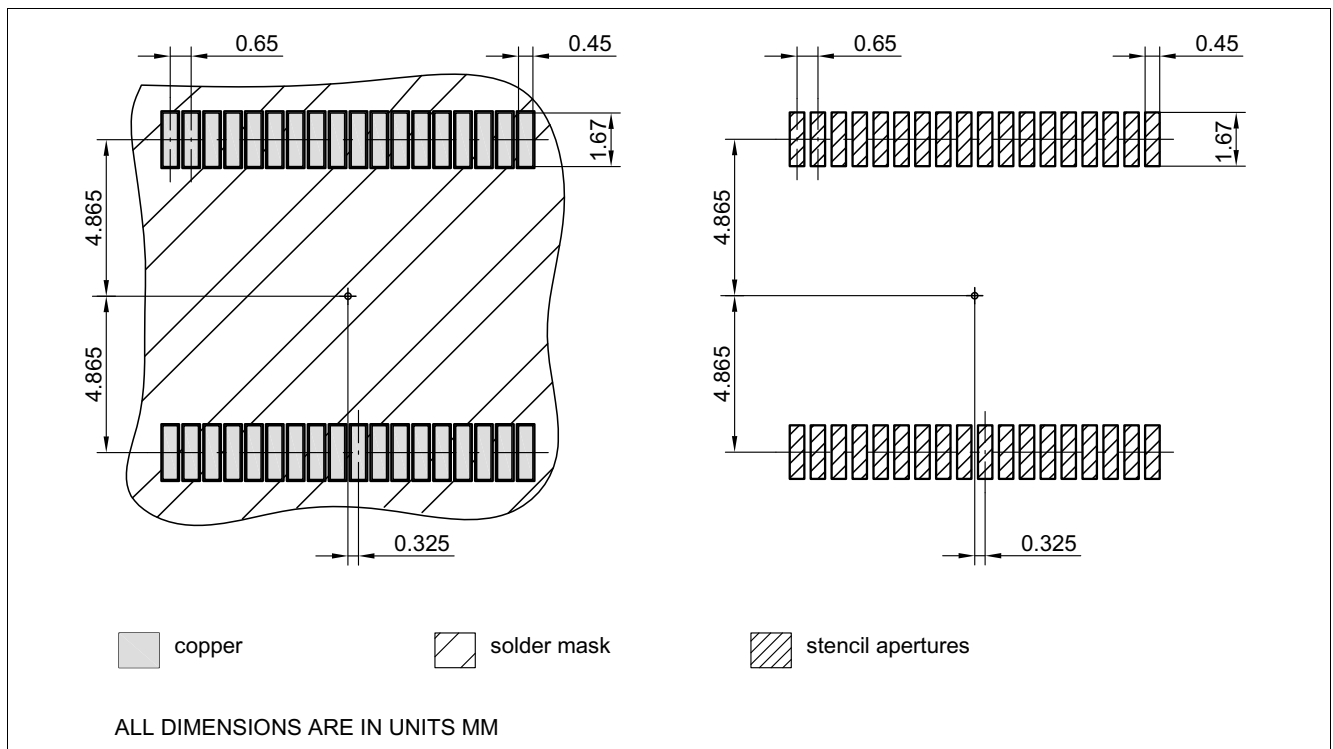

Figure 28 Recommended Footprint

Package Information

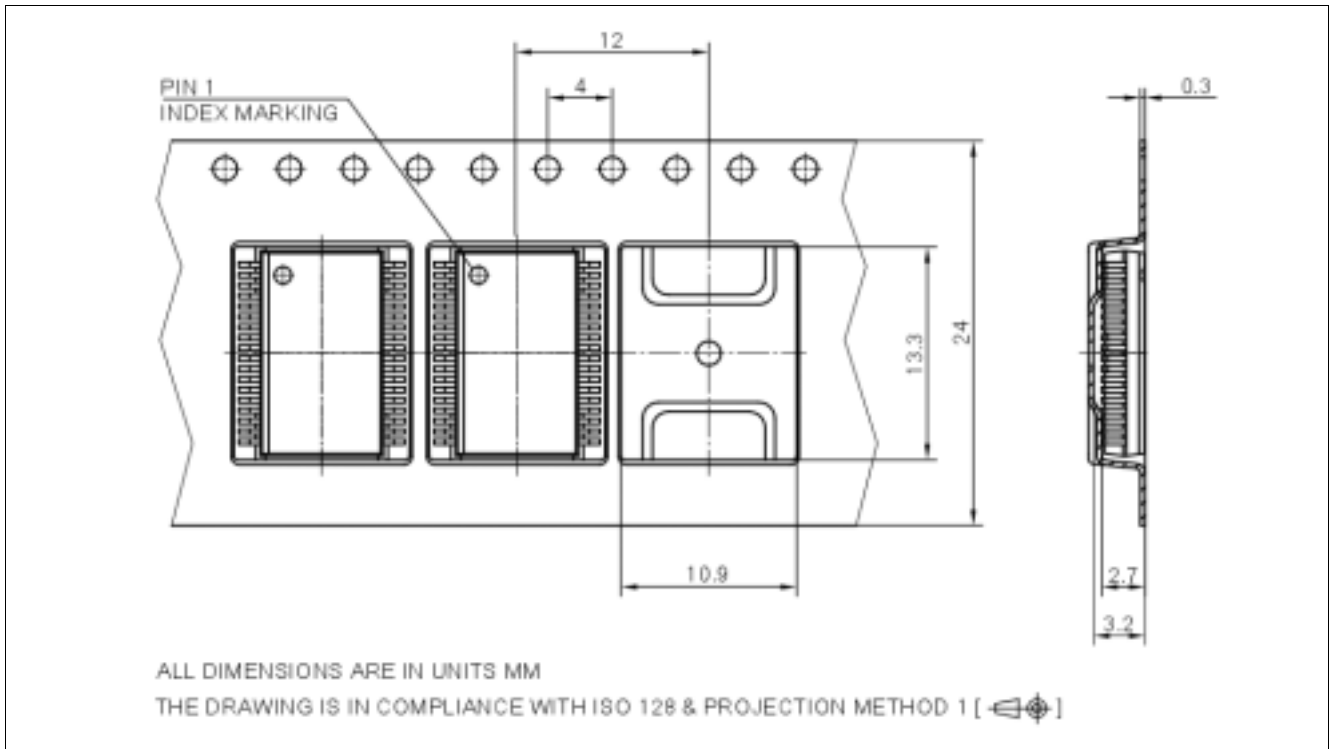

Figure 29 Packing Information (Tape & Reel)

Note: 1000 parts per reel, 1 reel per box, 330mm diameter of the reel.

Trademarks of Infineon Technologies AG

μ HVIC™, μ IPM™, μ PFC™, AU-ConvertIR™, AURIX™, C166™, CanPAK™, CIPOS™, CIPURSE™, CoolDP™, CoolGaN™, COOLiR™, CoolMOS™, CoolSET™, CoolSiC™, DAVE™, DI-POL™, DirectFET™, DrBlade™, EasyPIM™, EconoBRIDGE™, EconoDUAL™, EconoPACK™, EconoPIM™, EiceDRIVER™, eupec™, FCOS™, GaNpowIR™, HEXFET™, HITFET™, HybridPACK™, iMOTION™, IRAM™, ISOFACE™, IsoPACK™, LEDriviR™, LITIX™, MIPAQ™, ModSTACK™, my-d™, NovalithIC™, OPTIGA™, OptiMOS™, ORIGA™, PowIRaudio™, PowIRstage™, PrimePACK™, PrimeSTACK™, PROFET™, PRO-SIL™, RASIC™, REAL3™, SmartLEWIS™, SOLID FLASH™, SPOC™, StrongIRFET™, SupIRBuck™, TEMPFET™, TRENCHSTOP™, TriCore™, UHVIC™, XHP™, XMC™.

Trademarks updated November 2015

Other Trademarks

All referenced product or service names and trademarks are the property of their respective owners.

Edition 2019-01-16

Published by

Infineon Technologies AG

81726 Munich, Germany

© 2019 Infineon Technologies AG.

All Rights Reserved.

Do you have a question about any aspect of this document?

Email: erratum@infineon.com

IMPORTANT NOTICE

The information given in this document shall in no event be regarded as a guarantee of conditions or characteristics ("Beschaffungsgarantie").

With respect to any examples, hints or any typical values stated herein and/or any information regarding the application of the product, Infineon Technologies hereby disclaims any and all warranties and liabilities of any kind, including without limitation warranties of non-infringement of intellectual property rights of any third party.

In addition, any information given in this document is subject to customer's compliance with its obligations stated in this document and any applicable legal requirements, norms and standards concerning customer's products and any use of the product of Infineon Technologies in customer's applications.

The data contained in this document is exclusively intended for technically trained staff. It is the responsibility of customer's technical departments to evaluate the suitability of the product for the intended application and the completeness of the product information given in this document with respect to such application.

For further information on technology, delivery terms and conditions and prices, please contact the nearest Infineon Technologies Office (www.infineon.com).

WARNINGS

Due to technical requirements products may contain dangerous substances. For information on the types in question please contact your nearest Infineon Technologies office.

Except as otherwise explicitly approved by Infineon Technologies in a written document signed by authorized representatives of Infineon Technologies, Infineon Technologies' products may not be used in any applications where a failure of the product or any consequences of the use thereof can reasonably be expected to result in personal injury.