



presented by
EBVElektronik
 | An Avnet Company |

IDT
 Integrated Device Technology

SYNCHRONIZATION

Overview

Sensor Signal Conditioning ICs for Industrial and Consumer Applications





Easy-to-Use Sensor Signal Conditioner ICs

Designing sensor interfaces can be quite challenging and time consuming, and producing them in volume is often expensive due to long test cycles on costly production test equipment. IDT Sensor Signal Conditioner (SSC) ICs facilitate both design and production of sensor interfaces by providing programmable, highly accurate, wide gain and quantization functions combined with powerful, high-order digital correction and linearization algorithms.

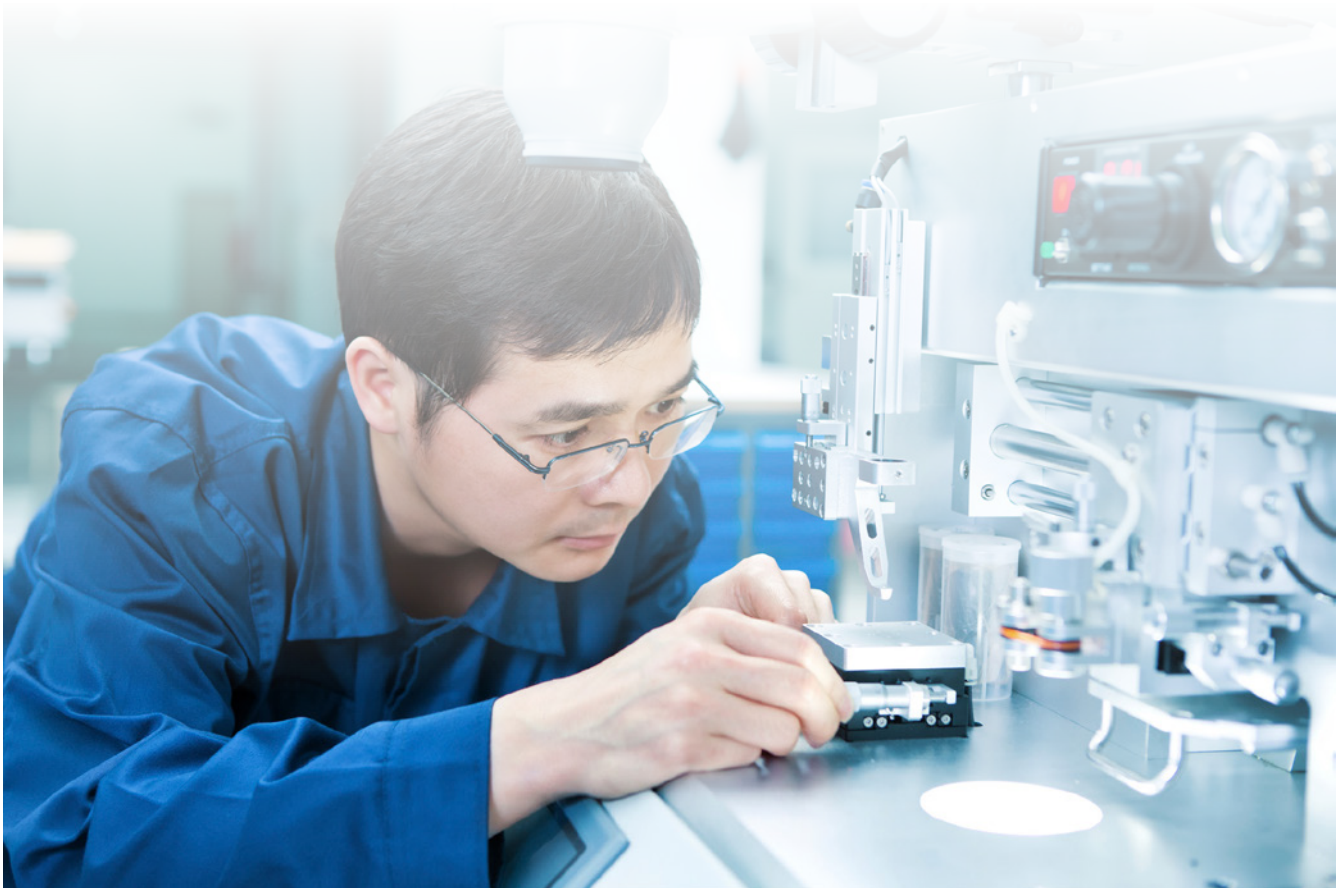

Sensor Signal Conditioning Basics

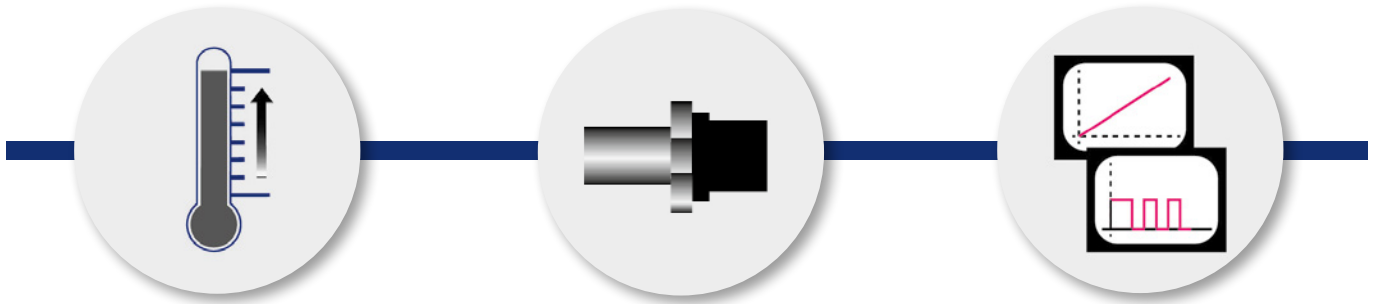

Sensor Signal

- Physical measure
 - pressure
 - torque
 - temperature
 - force
 - weight / load
 - and more

Signal Conditioning

- Signal transducing
- Signal amplification
- Signal conditioning (compensation of offset, non-linearity and temperature dependency)

Conditioned Output

- Linear analog ratiometric voltage, current loop
- Digital PWM, I²C, and OWI output

Typical SSC Block Diagram

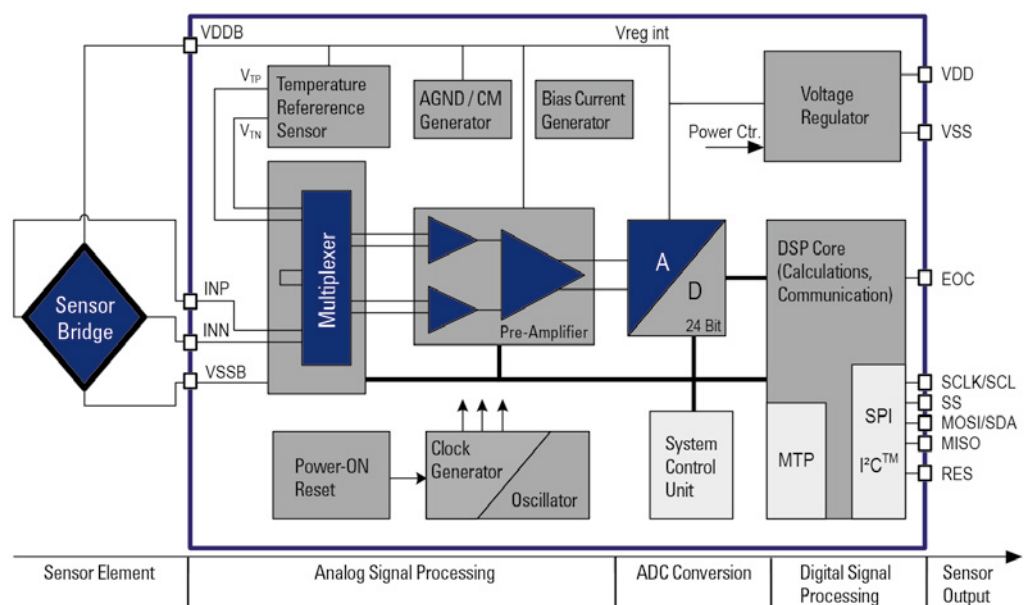



SSC Product Portfolio

IDT's Sensor Signal Conditioner ICs typically interface with two main sensor types: resistive bridges and differential capacitors. For each sensor type, further specialization allows selecting the optimal balance between price and performance for the required operating voltage and temperature range, gain, resolution, input/output format, and qualification level.

Our SSC ICs offer digital compensation of sensor offset, sensitivity, temperature drift, and nonlinearity in wide operational temperature ranges: -50°C to $+150^{\circ}\text{C}$ (maximum range).

Generation	1	2	3	4
Type	Resistive	Capacitive	Resistive	Resistive
Part Numbers	ZSC31010 ZSC31014 ZSC31015 ZSC31050	ZSSC3122 ZSSC3123	ZSSC3026 ZSSC3027 ZSSC3036	ZSSC3018 ZSSC3218 ZSSC3224
Resolution	up to 15 bit ADC resolution	up to 14 bit ADC resolution	up to 16 bit ADC resolution	up to 24 bit ADC resolution
Output	Analog and Digital	Digital	Digital	Digital
Market	Industrial	Consumer and Industrial		



Sensor Application Reference Designs



Oil Pressure and
Temperature Sensor



Pressure Sensing in
Consumer Electronics



Industrial Pressure
Sensor



Sensors for
White Goods

IDT SSC ICs Enable Easy Sensor Platform Development

- Analog and One-Wire interface
- Digital I²C & SPI output
- Resistive and capacitive sensor interface
- High analog gain for sophisticated sensors
- Industrial and consumer applications
- Low-power and battery-powered applications
- Single-pass calibration
- High ADC resolution up to 24 bit
- Wafer and packaged delivery forms

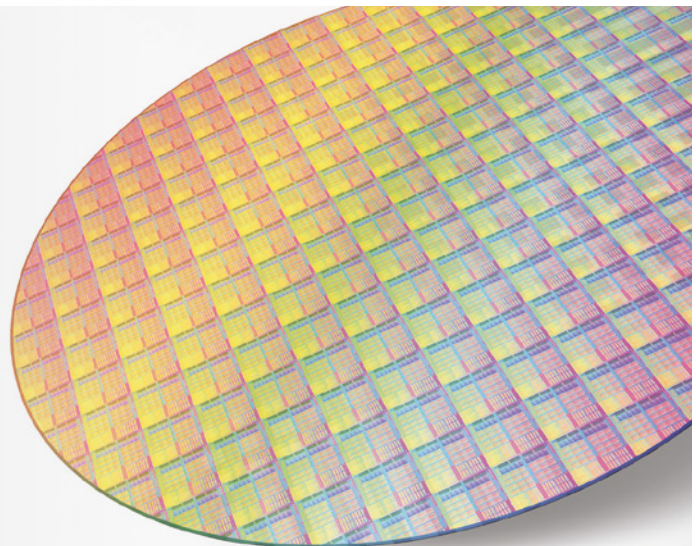

Highest Accuracy by Integrated Sensor Signal Conditioning

Before Calibration: ± 4500 counts Error

Figure 1 illustrates Absolute error [counts] from ideal linear bridge and temperature characteristic.

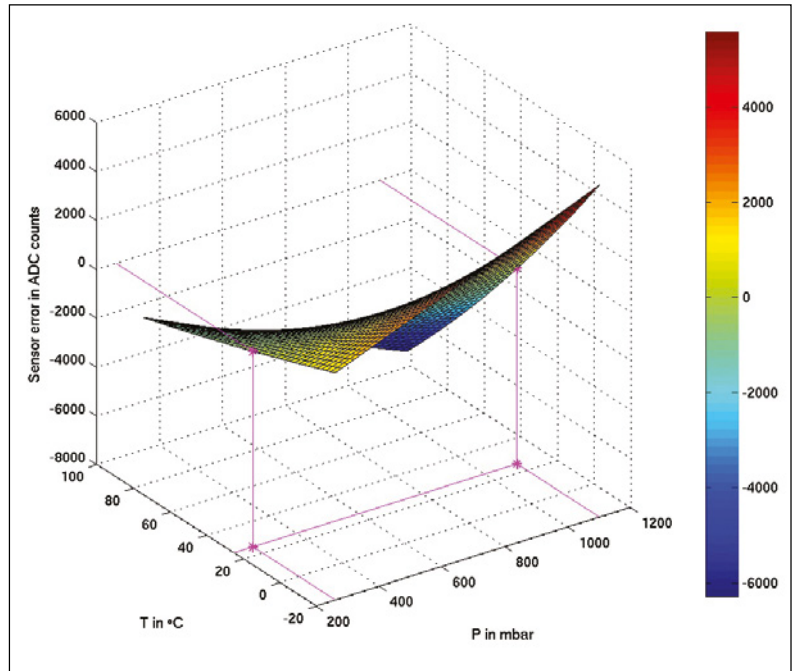

Figure 1

After Calibration: ± 60 counts Error

Figure 2 illustrates Absolute error with typical sensor after calibration: $\pm 0.1\%$ (± 60 counts)

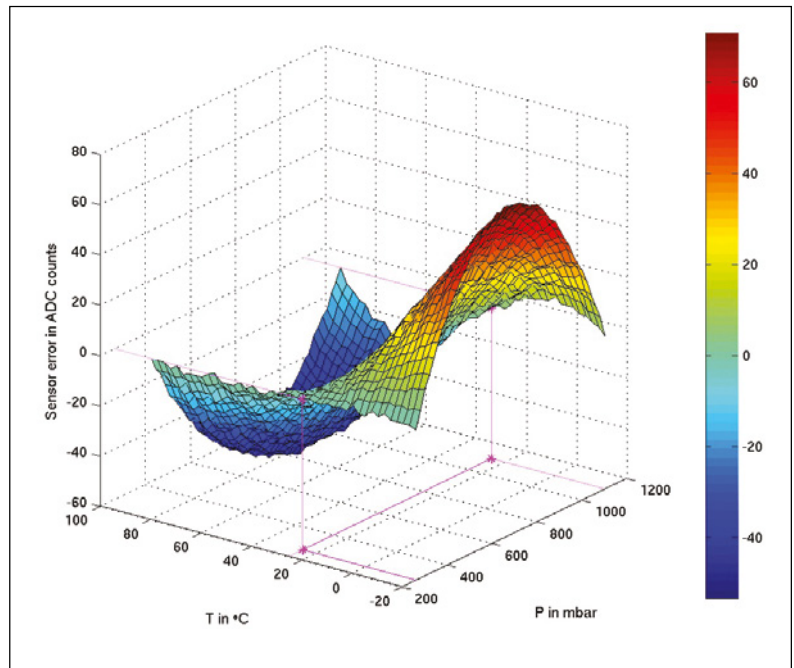
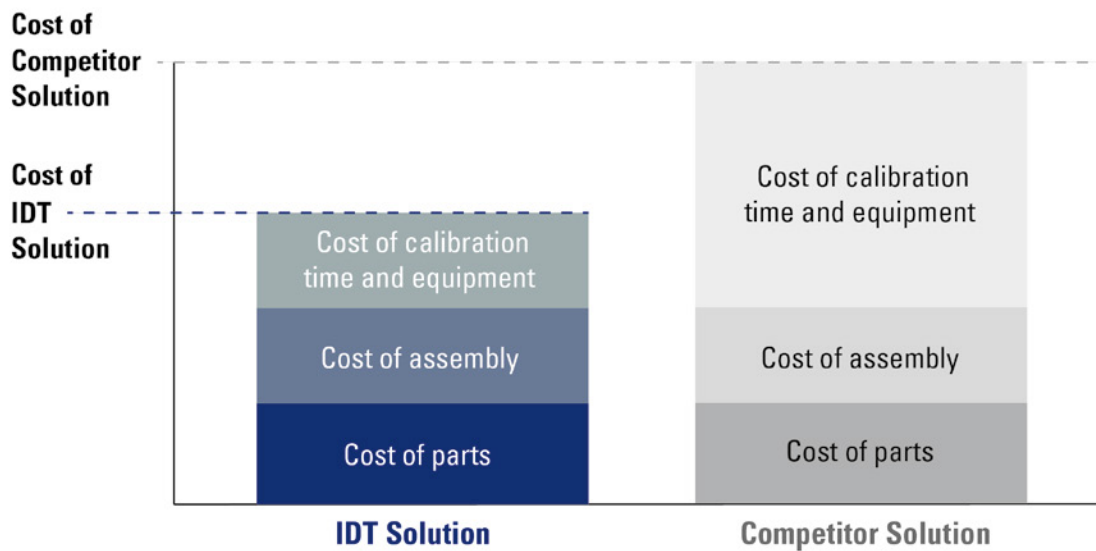

Figure 2



Lowest Total System Cost with IDT SSCs



IDT Sensor Signal Conditioners

IDT SSC's provide an advantage to our customers sensor modules both in performance as well as in the test and calibration process.

High Accuracy



Real resolution –
not inflated claims

Integrated Solutions

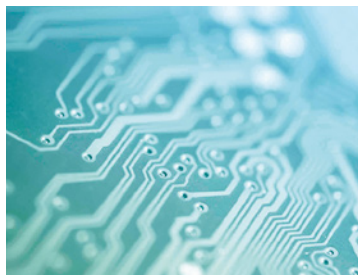

No external trimming and
single-pass calibration

Breadth of Product

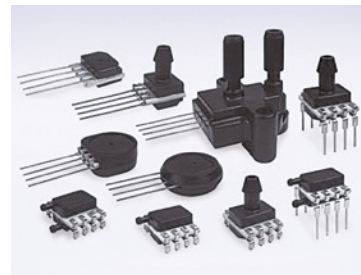

Resistive and capacitive
solutions with a variety of
output options



Industrial and Consumer SSC Portfolio

Part Number	Type	Voltage	Output	ADC	Package	Typical Application/Features
ZSC31010	Resistive	2.7 to 30 V	Analog/Digital	14 bit	SOIC, Wafer	Industrial/Analog Sensors
ZSC31014	Resistive	2.7 to 5.5 V	Digital	14 bit	SOIC, Wafer	Industrial/I ² C Sensors
ZSC31015	Resistive	2.7 to 30 V	Analog/Digital	14 bit	SOIC, Wafer	Industrial/Analog Sensors
ZSC31050	Resistive	2.7 to 40 V	Analog/Digital	15 bit	SSOP, Wafer	Industrial/Current Loop
ZSSC3026	Resistive	1.8 to 3.6 V	Digital	16 bit	Wafer	Consumer, White Good
ZSSC3036	Resistive	1.8 to 3.6 V	Digital	16 bit	Wafer	Industrial
ZSSC3027	Resistive	1.7 to 3.6 V	Digital	16 bit	Wafer	Stacked Die Assemblys
ZSSC3018	Resistive	1.68 to 3.6 V	Digital	18 bit	QFPN, Wafer	Industrial/White Good
ZSSC3218	Resistive	1.68 to 3.6 V	Digital	18 bit	QFPN, Wafer	Consumer/White Good
ZSSC3224	Resistive	1.68 to 3.6 V	Digital	24 bit	QFPN, Wafer	Industrial/Consumer
ZSSC3122	Capacitive	1.8 to 5.5 V	Digital, PDM	14 bit	TSSOP, Wafer	Consumer/White Good
ZSSC3123	Capacitive	2.3 to 5.5 V	Digital, PDM	14 bit	TSSOP, Wafer	Industrial

Why Choose IDT SSCs?

IDT SSC ICs are all-in-one, energy-efficient products that are easy-to-use and are supported by advanced software and expert technical support staff.



Decades of sensor design experience



Excellent evaluation and support tools



Unmatched technical support



Continued investment



Reduced time to market

To request samples, download documentation, or learn more, visit: idt.com/go/SSCs

CONTACT

EBV Elektronik GmbH & Co. KG
 D-85586 Poing
 Im Technologiepark 2-8
 Phone: +49 (0)8121 774-0
 Fax: +49 (0)8121 774-422