



life.augmented

Automotive Standard Analog Robustness and Performance



Contents

- 4 Introduction
- 6 Automotive grade qualification process
- 8 Application schematics
- 10 DFN/QFN Wettable flanks
automotive grade packages
- 12 Amplifiers & Comparators
- 12 Low-power operational amplifiers
- 14 Precision operational amplifiers
- 16 High output current & capacitive load
operational amplifiers
- 18 Fast operational amplifiers
- 20 Comparators
- 22 Grade 0 (150°C) amplifiers & comparators
- 24 Current-sense amplifiers
- 26 DC-DC converters
- 26 DC-DC conversion from car/truck battery -
asynchronous ICs
- 28 DC-DC conversion from car battery -
synchronous ICs

31	DC-DC converters for the post-regulation
32	LED Drivers
32	LED array drivers
34	LED row drivers
36	Linear Regulators LDO
36	LDO for the conversion from car battery
38	LDO for the post-regulation
41	Logic ICs
42	USB-C and PD controllers
44	Voltage references
45	Watchdog, reset and supervisor ICs
46	Current sensing in BLDC motor applications
48	Current sensing for 48 V batteries
50	eDesignSuite
51	Mobile apps

Introduction



ST provides a wide range of analog products dedicated to the challenging and demanding automotive market.

This brochure presents a large portfolio of ST's products and solutions dedicated to voltage regulation, DC-DC conversion, signal amplification, current sensing, and LED driving as well as many other small analog ICs that are needed for today's ever-growing automotive industry.

Thanks to innovative design techniques and a continuous focus on improving quality, ST offers high-performance devices that meet the specific requirements of the rigorous AEC-Q100 standard.

With a continuously growing portfolio offering the latest solutions in a wide variety of packages for powertrain, safety, and car-body systems to infotainment solutions, this brochure highlights the best products and solutions to help developers quickly get started with their designs as well as development tools for their day-to-day activities.

A LARGE PORTFOLIO OF PRODUCTS

Amplifiers and comparators



Current-sense amplifiers



DC-DC converters



LED drivers



Linear regulators (LDO)



Logic ICs



USB-C and PD controllers



Voltage references



Watchdog, reset, and supervisor ICs



FOR ALL AUTOMOTIVE APPLICATIONS



Automotive grade qualification process

80%

of all innovations
in the automotive
industry today
are enabled by
electronics



Our automotive products meet the specific and rigorous requirements of the automotive market. This is the result of continuous quality and reliability improvements gained through our close collaboration with leading automotive suppliers and car makers. From product conception to delivery and beyond, our constant focus on learning and upgrading our quality processes, ensure we reach the highest level of excellence in the semiconductor industry.



Very high level of in-house parametric testing equipment



100% electrical testing with very extensive coverage coupled with automatic visual inspection



Part Average Testing (PAT) to detect and remove parts tested "pass" but potentially weak in reliability



Hot test & Junction Verification Test (JVT) at Final test for SOT23, Mini-SO, SO, TSSOP, QFN/DFN



A specific commercial product number

COMPLIANCE WITH

- IATF16949
- VDA 6.3
- AEC-Q100
- AEC-Q001
- AEC-Q002
- PPAP provided



CUSTOMER QUALITY

- Customer requirements
- Complaint management
- Product return process



CHANGE MANAGEMENT

- Product/Process Change Notifications
- Product Termination Notifications



MANUFACTURING & SUPPLY CHAIN QUALITY

- Non-conformity management
- Supplier quality management
- Traceability



QUALITY IN PRODUCT & TECHNOLOGY DEVELOPMENT

- Test flow
- Technology development
- Product monitoring



Application schematics

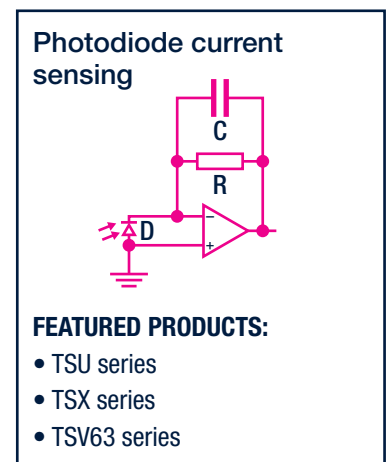
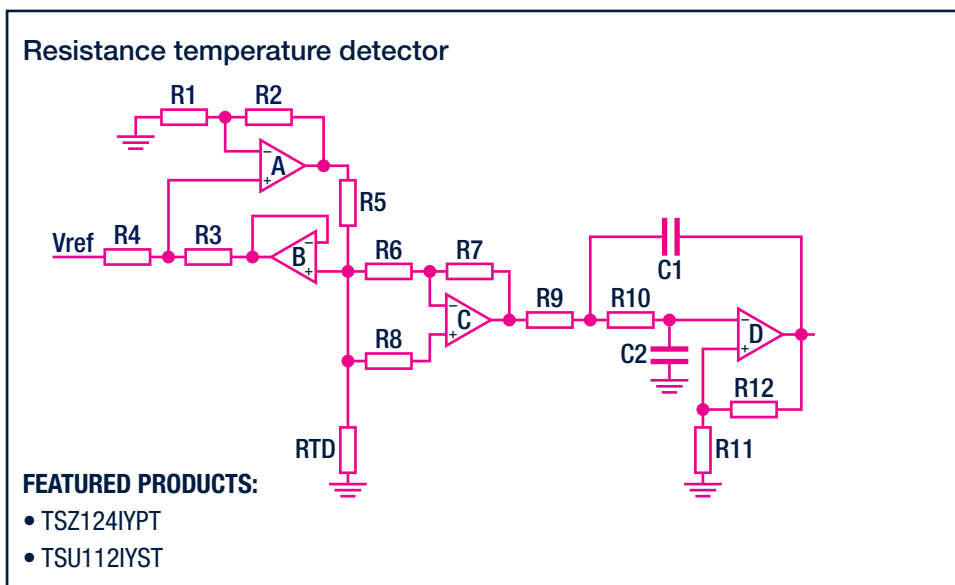
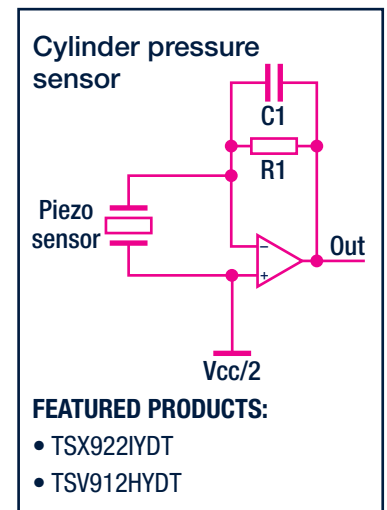
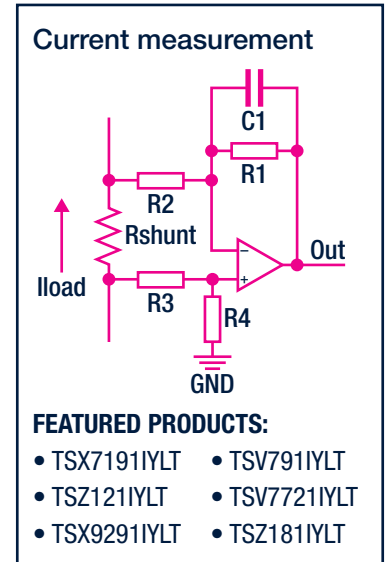
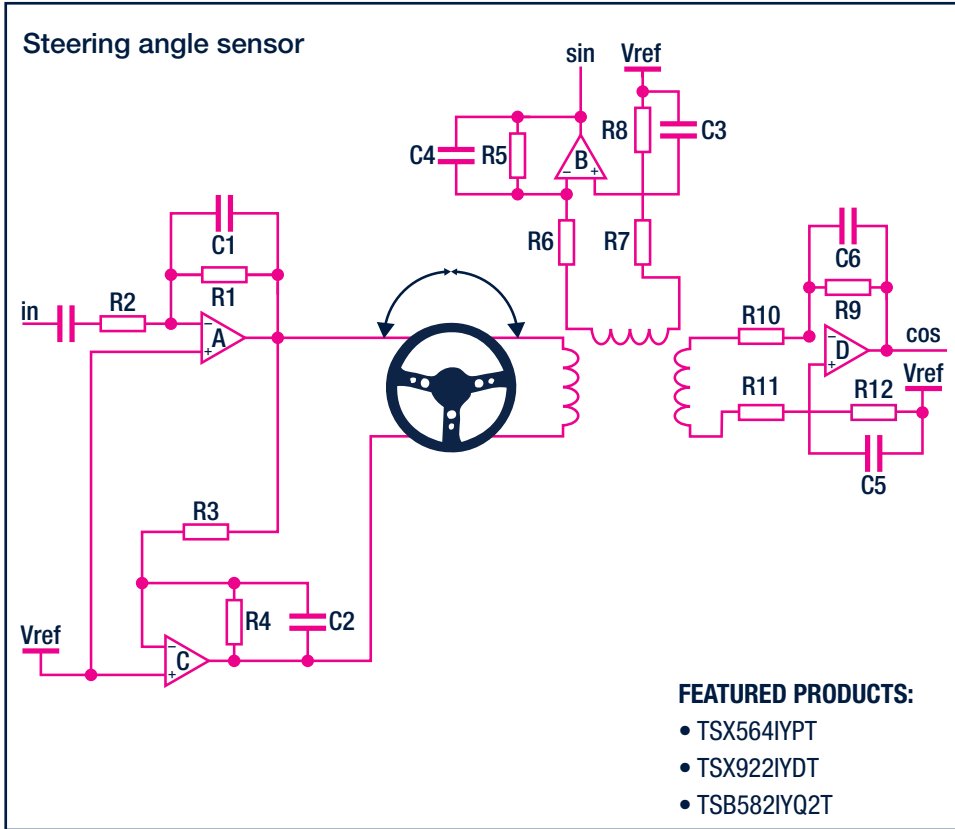

Isolated supply for gate drivers in On-Board Charging (OBC)

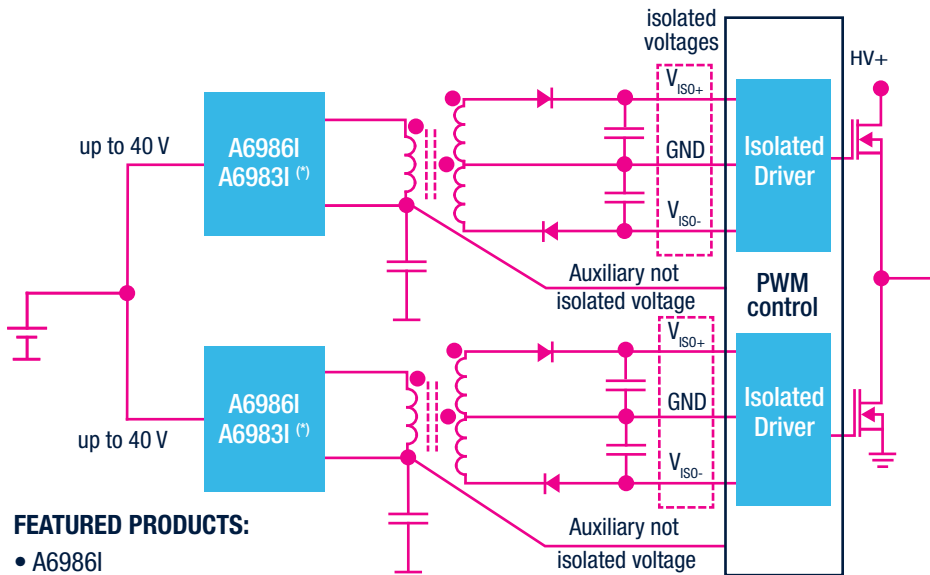

FEATURED PRODUCTS:

- A6986I
- A6983I (*)

(*) Product under development

Isolated supply for Battery Management System (BMS) in Electric Vehicle (EV)

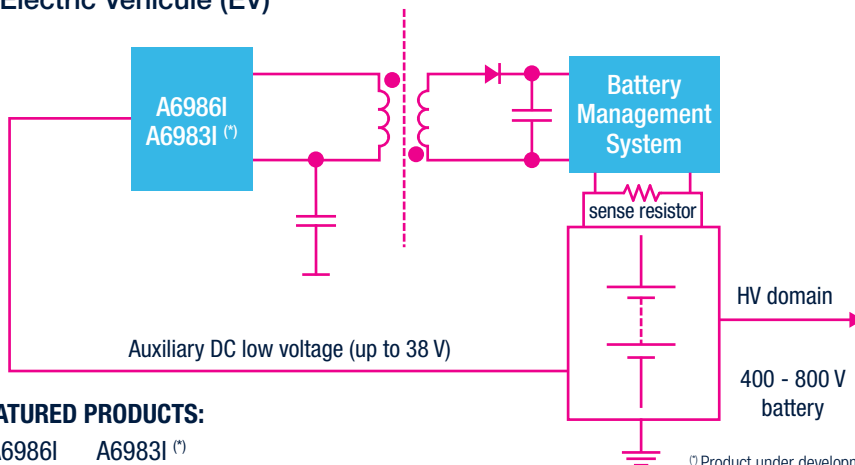

FEATURED PRODUCTS:

- A6986I
- A6983I (*)

(*) Product under development

Rear LED Lighting

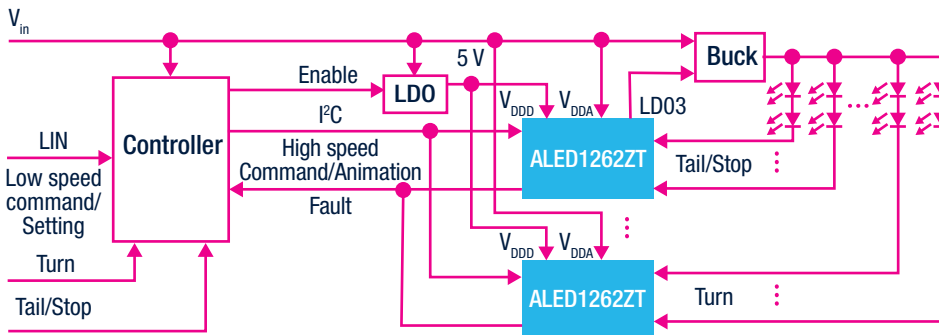

FEATURED PRODUCTS:

- ALED1262ZT (LED DRIVER)
- LD040LY (LDO)
- A7986A (DC-DC BUCK CONVERTER)

DFN/QFN wettable flanks

Automotive Grade packages

MAIN FEATURES AND BENEFITS

Packages with wettable flanks (WF) are a new type of plastic packages for ICs, where a modification of the mounting edge design has a fillet as termination that allows you to see and test that a proper connection has been made on a pad that is for the most part not visible once soldered on a board.

Using a QFN/DFN package with a wettable flanks enables Automated Optical Inspection (AOI) of the soldering, which can increase reliability, while reducing cost at the same time.

STMicroelectronics is adopting this most innovative solution to be in line with the automotive industry stringent requirements.

Packages with wettable flanks (WF) are Immune to soldering cracking for more than 3,000 thermal cycles at -40 to 125 °C, 1 cycle per hour, 1.0 mm high TG FR-4 PCB (Printed Circuit Board).

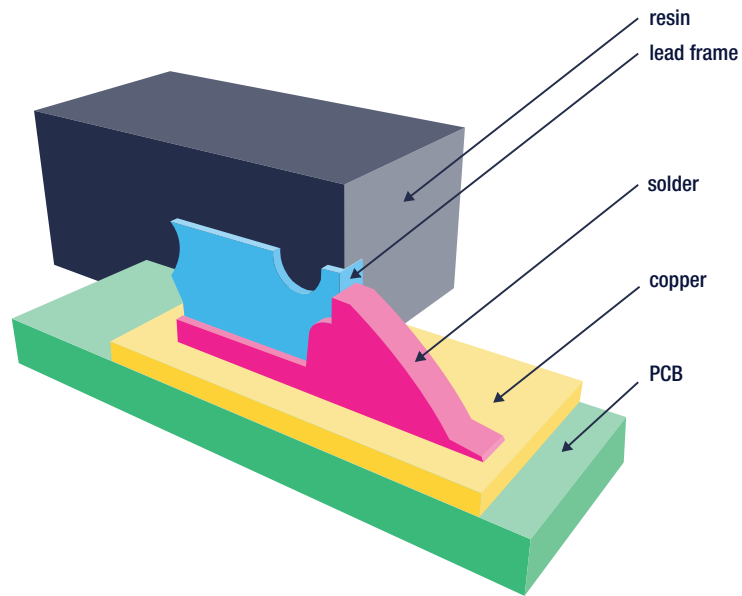

Wettable flanks package structure – internal layers

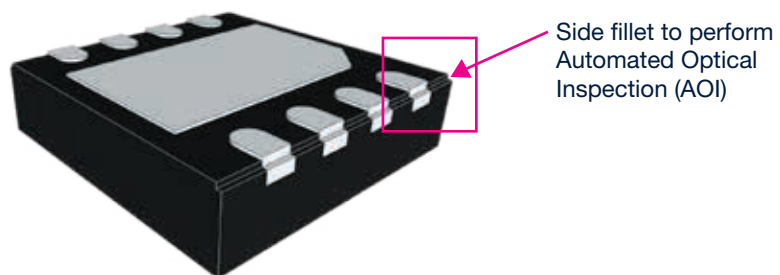

DFN8
(3x3 WF)

(thickness 0.75mm)

Wettable flanks package example - external view

DFN/QFN Wettable flanks Automotive Grade packages

Family	CP	Description	Package	Width (mm)	Length (mm)	Thickness (mm)
Amplifier	LM2904YQ6T ^(*)	Low power, bipolar operational amplifier	DFN8 (2x2 WF)	2	2	0.75
Amplifier	TSB572IYQ2T	Low-power, 2.5 MHz, RR IO, 36 V BiCMOS operational amplifier	DFN8 (3x3 WF)	3	3	0.75
Amplifier	TSB582IYQ2T ^(*)	Low-power, 3.1 MHz, RR IO, 36 V BiCMOS operational amplifier	DFN8 (3x3 WF)	3	3	0.75
Amplifier	TSB622IYQ3T ^(*)	Low power, 1.7 MHz, rail-to-rail output, 36V operational amplifier	DFN8 (3x3 WF)	3	3	0.75
Amplifier	TSU112IYQ3T	Nanopower (900 nA) high accuracy (150 μ V) 5V CMOS operational amplifier	DFN8 (2x2 WF)	2	2	0.75
Amplifier	LM2902YQ5T	Low power, bipolar op-amp	QFN16 (3x3 WF)	3	3	0.9
Comparator	LM2903YQ3T	Low power dual voltage comparator	DFN8 (2x2 WF)	2	2	0.75
Comparator	TS3011IYQ3T	Rail-to-rail high-speed comparator	DFN8 (2x2 WF)	2	2	0.75
Current sense amplifier	TSC210IYQT ^(*)	Low / High side bidirectional, zero-drift, current sense amplifier	QFN10 (1.8x1.4 WF)	1.8	1.4	0.75
Current sense amplifier	TSC211IYQT ^(*)	Low / High side bidirectional, zero-drift, current sense amplifier	QFN10 (1.8x1.4 WF)	1.8	1.4	0.75
Current sense amplifier	TSC212IYQT ^(*)	Low / High side bidirectional, zero-drift, current sense amplifier	QFN10 (1.8x1.4 WF)	1.8	1.4	0.75
Current sense amplifier	TSC213IYQT ^(*)	Low / High side bidirectional, zero-drift, current sense amplifier	QFN10 (1.8x1.4 WF)	1.8	1.4	0.75
Current sense amplifier	TSC214IYQT ^(*)	Low / High side bidirectional, zero-drift, current sense amplifier	QFN10 (1.8x1.4 WF)	1.8	1.4	0.75
Current sense amplifier	TSC215IYQT ^(*)	Low / High side bidirectional, zero-drift, current sense amplifier	QFN10 (1.8x1.4 WF)	1.8	1.4	0.75
DC-DC converter	A6983 ^(*)	Low quiescent current, Synchronous step-down switching regulator to deliver up to 3 A DC	QFN16 (3x3 WF)	3	3	0.8
DC-DC converter	A6983I ^(*)	Low quiescent current, Synchronous isolated step-down switching regulator to deliver up to 3 A DC	QFN16 (3x3 WF)	3	3	0.8
Linear regulator (LDO)	LD39100Y	Low dropout voltage, low quiescent current, linear voltage regulator	DFN6 (3x3 WF)	3	3	0.9
Linear regulator (LDO)	LD49100Y	Low quiescent current, low-noise voltage regulator with soft start	DFN6 (3x3 WF)	3	3	0.9
Linear regulator (LDO)	LD59150Y	Low dropout linear voltage regulator with programmable soft-start	DFN10 (3x3 WF)	3	3	0.9
Linear regulator (LDO)	LD040LY	Low quiescent current, battery connected linear voltage regulator	DFN6 (3x3 WF)	3	3	0.9
Linear regulator (LDO)	LDQ40Y	Low quiescent current, battery connected linear voltage regulator	DFN6 (2x2 WF)	2	2	0.8
USB Type-C controller	STUSB1700YQTR	USB Type-C controller (with short-to-VBUS protection)	QFN24 (4x4 WF)	4	4	0.95
USB PD controller	STUSB4700YQTR	Stand-alone USB PD controller (with short-to-VBUS protection)	QFN24 (4x4 WF)	4	4	0.95

^(*) Products under development

Amplifiers & Comparators

LOW-POWER OPERATIONAL AMPLIFIERS

TSB571/2: low-power, 2.5 MHz, rail-to-rail input and output, 36 V operational amplifier

The TSB571 (single) and TSB572 (dual) operational amplifiers offer an extended voltage operating range from 4 to 36 V and rail-to-rail input/output.

The TSB57 family offers a very good speed/power consumption ratio with 2.5 MHz gain bandwidth product while consuming only 380 μ A typically with a 36 V supply.

The TSB57 stability and robustness make it an ideal solution for applications with a wide voltage range.



Slew rate vs. supply voltage and temperature

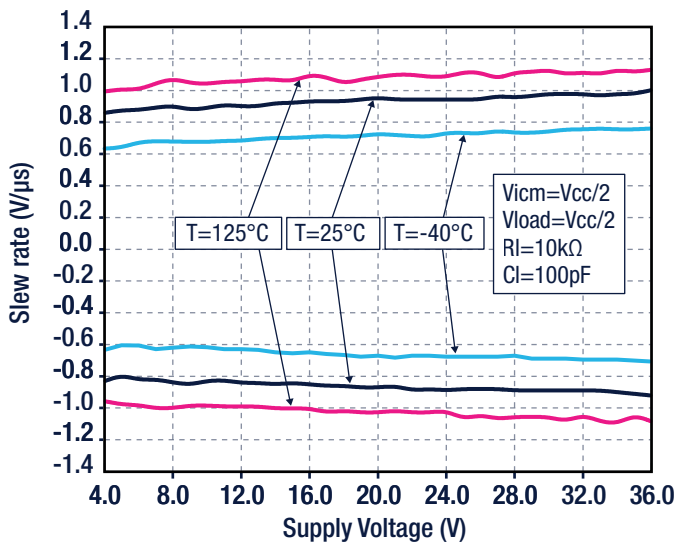

Output current vs. output voltage and temperature

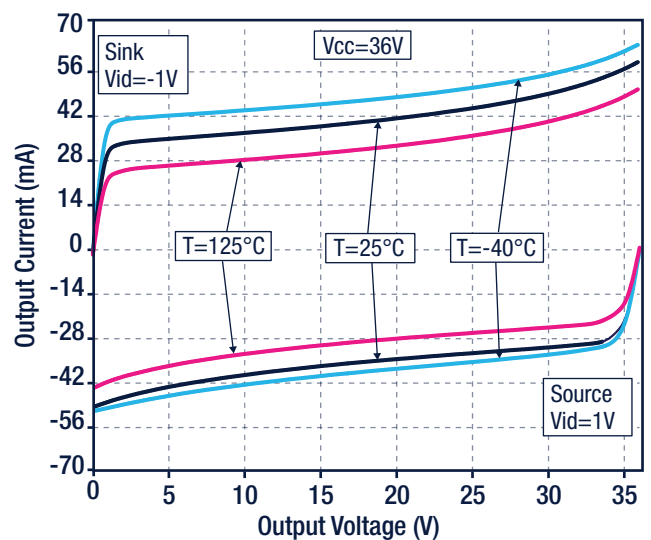

FEATURES

- Low-power consumption: 380 μA (typ.)
- Wide supply voltage: 4 to 36 V
- Rail-to-rail input and output
- Gain bandwidth product: 2.5 MHz
- Low input bias current: 30 nA (max.)
- No phase reversal
- High tolerance to ESD: 4 kV (HBM)



Low-power operational amplifiers

Part number	Typ. I_{cc} per channel (μA)	Min. V_{cc} (V)	Max. V_{cc} (V)	Typ. GBP (MHz)	Typ. SR (V/ μs)	Max. V_{io} @ 25 °C (μV)	Typ. I_{out} (mA)	Rail to rail		Package Single	Package Dual	Package Quad
								In	Out			
TSU111IY/2IY	1	1.5	5.5	0.012	0.0017	150	41	Yes	Yes	SOT23-5	Mini-SO8, DFN8 (2x2 WF)	NA
TS934	20	2.7	10	0.1	0.05	10 000	5	No	Yes	NA	NA	S014
TSZ121/2/4	31	1.8	5.5	0.4	0.19	5	17	Yes	Yes	SOT23-5	S08, Mini-SO8	TSSOP14
TSV521A/2A/4A	45	2.7	5.5	1.15	0.89	600	55	Yes	Yes		Mini-SO8	
TSX631A/2A/4A	45	3.3	16	0.2	0.12	500	90	Yes	Yes		Mini-SO8	
TSV631/2/4	60	1.5	5.5	0.88	0.34	500	69	Yes	Yes		S08	
TSB611/2	103	2.7	36	0.56	0.18	1 000	60	No	Yes		S08, Mini-SO8	NA
TSX561A/2A/4A	250	3	16	0.9	1.1	600	90	Yes	Yes		Mini-SO8	TSSOP14
TSB622	310	2.7	36	1.7	0.6	1 000	45	No	Yes		NA	DFN8 (3x3 WF) [†] , S08, Mini-SO8
TSB571/2	380	4.0	36.0	2.5	0.88	1 500	65	Yes	Yes	SOT23-5	Mini-SO8, DFN8 (3x3 WF)	NA
TS912B/14A	400	2.7	16	1.4	1	2 000	70	Yes	Yes	NA	S08	S014
TS1871A/2A/4A	400	1.8	6	1.8	0.6	1 000	72	Yes	Yes	SOT23-5	S08, TSSOP8	S014, TSSOP14
TSV321A/358A/324A	500	2.5	6	1.4	0.6	1 000	80	Yes	Yes		S08, TSSOP8	S014, TSSOP14
TS512A/14A	500	6	30	3	1.5	500	23	No	No	NA	S08	NA
TS321A	600	3	30	0.8	0.4	2 000	40	No	No	SOT23-5	NA	NA
TSX711A/12	660	2.7	16	2.7	1.2	100	54	Yes	Yes		S08, Mini-SO8	
TSX7191A/92	660	2.7	16	8.5	2.4	100	70	Yes	Yes			
TSZ181/2	700	2.2	5.5	3	4.7	25	27	Yes	Yes			
TSV911A/2A/4A	780	2.5	5.5	8	4.5	1 500	35	Yes	Yes	SOT23-5, S08	S08, Mini-SO8	S014, TSSOP14
TS507	850	2.7	5.5	1.9	0.6	100	115	Yes	Yes	SOT23-5	NA	
TS9222/9224	900	2.7	12	4	1.3	500	80	Yes	Yes	NA	S08, TSSOP8	S014, TSSOP14
TS951/2/4	950	2.7	12	3	1	6 000	22	Yes	Yes	SOT23-5	S08, Mini-SO8	S014, TSSOP14

[†] Product under development

PRECISION OPERATIONAL AMPLIFIERS

TSZ181/2: Very high accuracy (25 μV) zero drift 5V CMOS dual op amps with GBP = 3 MHz

The TSZ181, TSZ182 are single-, dual- operational amplifiers featuring very low offset voltages with virtually zero drift versus temperature changes.

The TSZ18 family offers rail-to-rail input and output, excellent speed/power consumption ratio, and 3 MHz gain bandwidth product, while consuming just 1 mA at 5 V. The device also features an ultra-low input bias current. These features make the TSZ18 ideal for high-accuracy high-bandwidth sensor interfaces.



Input offset voltage vs. temperature for $V_{cc} = 5\text{ V}$

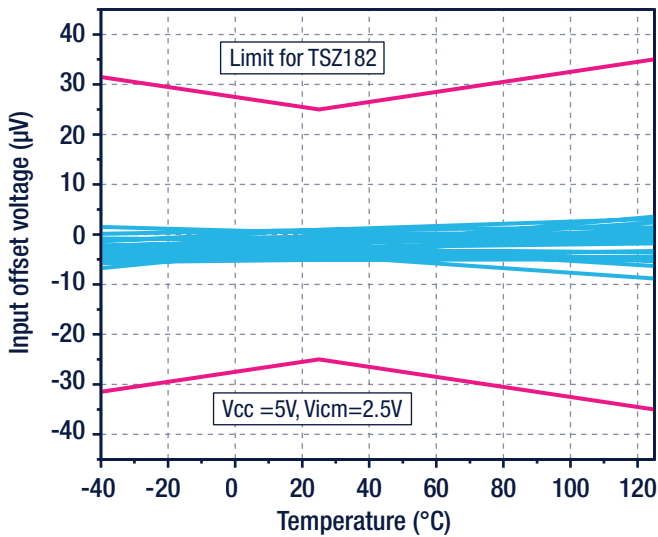

FEATURES

- Very high accuracy and stability: offset voltage 25 μV (max.) at 25 $^{\circ}\text{C}$, 35 μV over full temperature range (-40 to 125 $^{\circ}\text{C}$)
- Rail-to-rail input and output
- Low supply voltage: 2.2 to 5.5 V
- Low power consumption: 1 mA (max.) at 5 V
- Gain bandwidth product: 3 MHz
- Slew rate of 4.7 V/ μs

Positive slew rate vs. Supply voltage

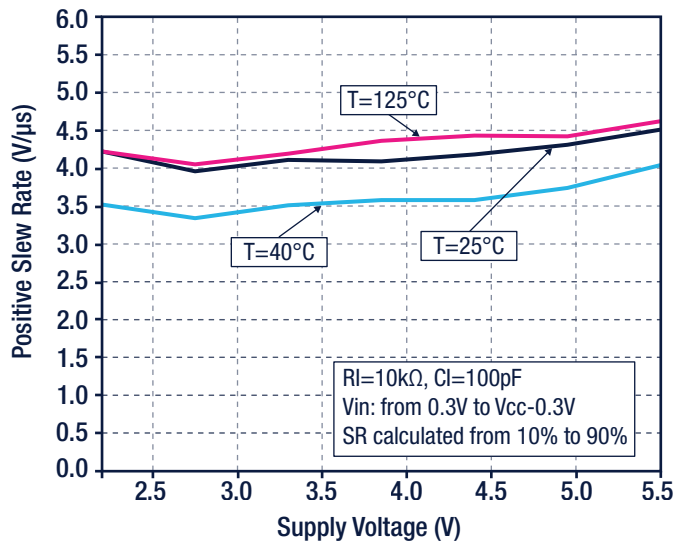

Precision operational amplifiers

Part number	Max. V_{IO} @ 25 °C (μ V)	Typ. V_{IO} drift (μ V/°C)	Max. I_{IB} @ 25 °C (pA)	Min. V_{CC} (V)	Max. V_{CC} (V)	Typ. GBP (MHz)	Typ. SR (V/ μ s)	Typ. I_{CC} per channel (mA)	Typ. 1kHz noise (nV/ \sqrt Hz)	Rail to rail		Package Single	Package Dual	Package Quad
										In	Out			
TSZ121/2/4	5	0.01	200	1.8	5.5	0.4	0.19	0.031	37	Yes	Yes	SOT23-5	S08, Mini-S08	TSSOP14
TSZ181/2	25	0.01	200	2.2	5.5	3	4.7	0.7	37	Yes	Yes			NA
TSX711A/12	100	0.8	50	2.7	16	2.7	1.2	0.66	22	Yes	Yes			
TS507	100	1	70 000	2.7	5.5	1.9	0.6	0.85	12	Yes	Yes		NA	
TSX7191A/2	100	0.8	50	2.7	16	8.5	2.4	0.66	22	Yes	Yes		S08, Mini-S08	
TSU111Y/2IY	150	0.5	10	1.5	5.5	0.012	0.0017	0.001	200	Yes	Yes		SOT23-5	DFN8, Mini-S08
TSV7721/2	200	1.7	300	1.8	5.5	22	11	1.7	7	No	Yes	SOT23-5	S08, Mini-S08	NA
TSV772	200	1.7	300	2.0	5.5	20	13	1.9	7	Yes	Yes	NA	S08, Mini-S08	NA
TSV782 (*)	200	1.7	300	2.0	5.5	30	19	3.3	14	Yes	Yes	NA	S08, Mini-S08	NA
TSV791/2	200	1.7	300	2.2	5.5	50	30	5.5	6.5	Yes	Yes	SOT23-5	S08, Mini-S08	NA
TSB711A/12A	300	2.8	300 000	2.7	36.0	6.0	3.00	1.800	12	Yes	Yes	SOT23-5	S08, Mini-S08	NA
TSB7191A/92A	300	2.8	300 000	2.7	36.0	22	12.0	1.8	12	Yes	Yes			NA
TSV631A/2A/4A	500	2	10	1.5	5.5	0.88	0.34	0.06	60	Yes	Yes	SOT23-5	S08	TSSOP14
TS9222/4	500	2	55 000	2.7	12	4	1.3	0.9	9	Yes	Yes	NA	S08, TSSOP8	S014, TSSOP14
TS512A/4A	500	2	150 000	6	30	3	1.5	0.5	8	No	No	NA	S08	NA
TSX561A/2A/4A	600	2	100	3	16	0.9	1.1	0.25	48	Yes	Yes	SOT23-5	Mini-S08	TSSOP14
TSX631A/2A/4A	700	1	100	3.3	16	0.2	0.12	0.045	60	Yes	Yes			
TS9511	800	2	70 000	2.7	12	3	1	0.95	25	Yes	Yes		NA	
TSV851A/2A/4A	800	1	60 000	2.3	5.5	1.3	0.7	0.13	30	No	Yes		S08, Mini-S08	TSSOP14
LMV821A/2A/4A	800	1	120 000	2.5	5.5	5.5	1.9	0.4	16	No	Yes		S08, TSSOP8	S014, TSSOP14

(*) Product under development

HIGH OUTPUT CURRENT & CAPACITIVE LOAD OPERATIONAL AMPLIFIERS

TSB582: high output current 36 V, 3.1 MHz with thermal shutdown and current limiter

The TSB582 is a high performance dual operational amplifier featuring high supply voltages and high output current capability while being protected through internal current limiting and thermal shutdown. Enhanced ESD and RF immunity facilitate the use in harsh automotive environments. The two high output current amplifiers of the TSB582 allow for driving loads directly in bridge tied mode or, connected in parallel, make it possible to double the output sink/source current. Additionally, the TSB582 is available in the two space-saving packages SO-8 with exposed pad and DFN8 with wettable flanks. Where both are qualified for automotive applications over a temperature range of -40 °C to +125 °C.

Output current vs. Output voltage and temperature

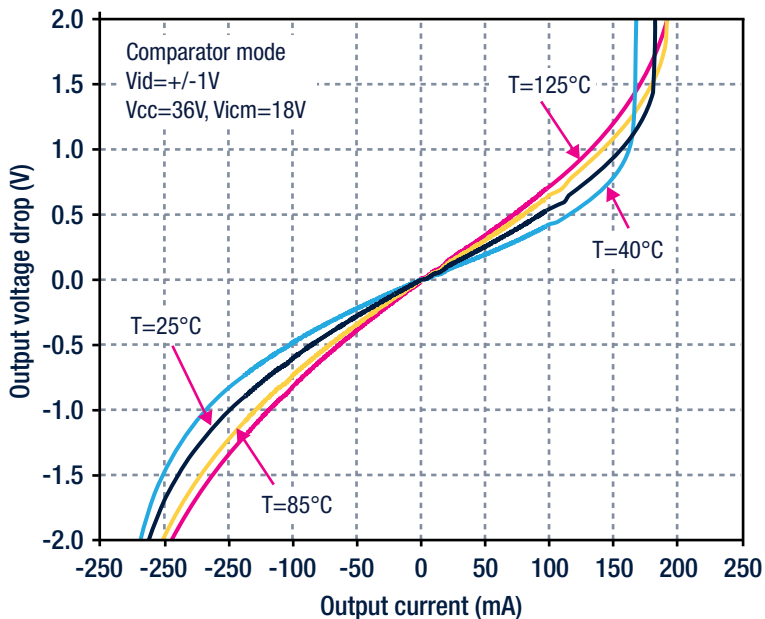

FEATURES

- Wide supply voltage 4 V to 36 V
- High output current 2 x 200 mA
- Gain bandwidth product: 3.1MHz
- Rail-to-rail output, low rail input
- Internal thermal shutdown and output current limiter
- High tolerance to ESD: 4kV HBM
- Enhanced RF noise immunity
- Extended temperature range: -40 °C to 125 °C

Input offset distribution

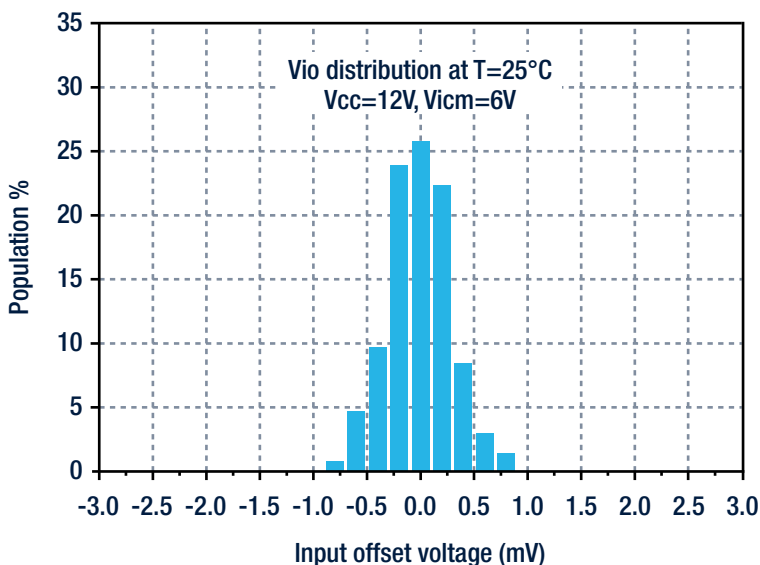

High output current & capacitive load operational amplifiers

Part number	Typ. I_{OUT} (mA)	Min. V_{CC} (V)	Max. V_{CC} (V)	Typ. GBP (MHz)	Typ. SR (V/ μ s)	Typ. I_{CC} per channel (mA)	Rail to rail		Package Single	Package Dual	Package Quad
							In	Out			
TSV321A/358A/324A	80	2.5	6	1.4	0.6	0.5	Yes	Yes	SOT23-5	S08, TSSOP8	S014, TSSOP14
TS9222/4	80	2.7	12	4	1.3	0.9	Yes	Yes	NA	S08, TSSOP8	S014, TSSOP14
TS921/2/4	80	2.7	12	4	1.3	1	Yes	Yes	NA	S08, TSSOP8	S08, TSSOP14
TSX561A/2A/4A	90	3	16	0.9	1.1	0.25	Yes	Yes	SOT23-5	Mini-S08	TSSOP14
TSX631A/2A/4A	90	3.3	16	0.2	0.12	0.045	Yes	Yes			TSSOP14
TS507	115	2.7	5.5	1.9	0.6	0.85	Yes	Yes		NA	
TS982	200	2.5	5.5	2.2	0.7	5.5	Yes	Yes	NA	S08	NA
TSB582	200	4.0	36	3.1	2.0	2.4	No	Yes	NA	DFN8 (3x3 WF) [Ⓞ] , S08	NA

[Ⓞ] Product under development



FAST OPERATIONAL AMPLIFIERS

TSV791/TSV792: high bandwidth (50 MHz) low offset (200 μ V) rail-to-rail 5 V op-amps

The TSV791 and TSV792 are single and dual 50 MHz-bandwidth unity-gain-stable amplifiers. The rail-to-rail input stage and the slew rate of 30 V/ μ s make the TSV791 and TSV792 ideal for low-side current measurement. The excellent accuracy provided by maximum input voltage of 200 μ V allows amplifying accurately small amplitude input signal. The TSV79x can operate from a 2.2 V to 5.5 V single supply; it can typically handle an output capacitor up to 1 nF and is fully specified on a load of 22 pF, therefore allowing easy usage as A/D converters input buffer.



Open loop Bode diagram at $V_{cc}=5V$

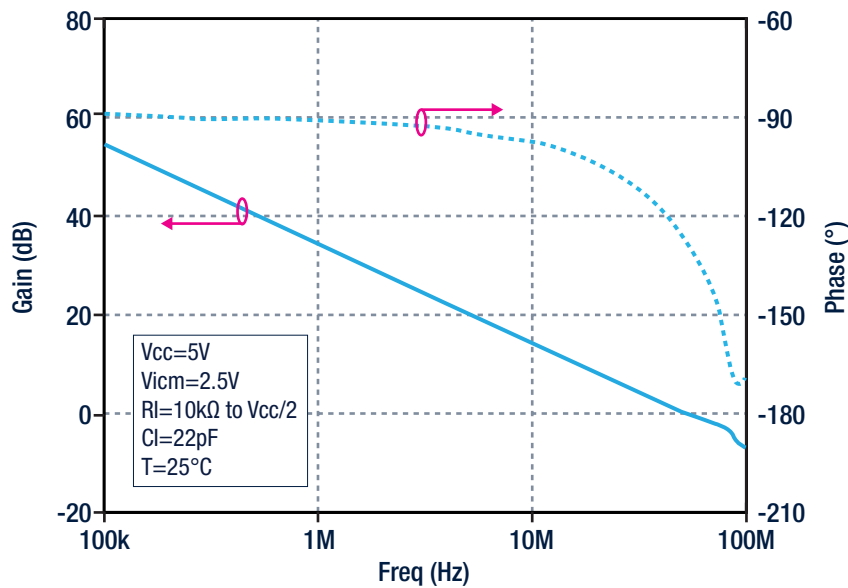

FEATURES

- Gain bandwidth product 50 MHz, unity gain stable
- Slew rate 30 V/ μ s
- Low input offset voltage 50 μ V typ., 200 μ V max.
- Low input bias current: 2 pA typ.
- Low input voltage noise density 6.5 nV/ \sqrt{Hz} @ 10 kHz
- Wide supply voltage range: 2.2 V to 5.5 V
- Rail-to-rail input and output
- Extended temperature range: -40 $^\circ C$ to +125 $^\circ C$

Slew rate vs V_{cc}

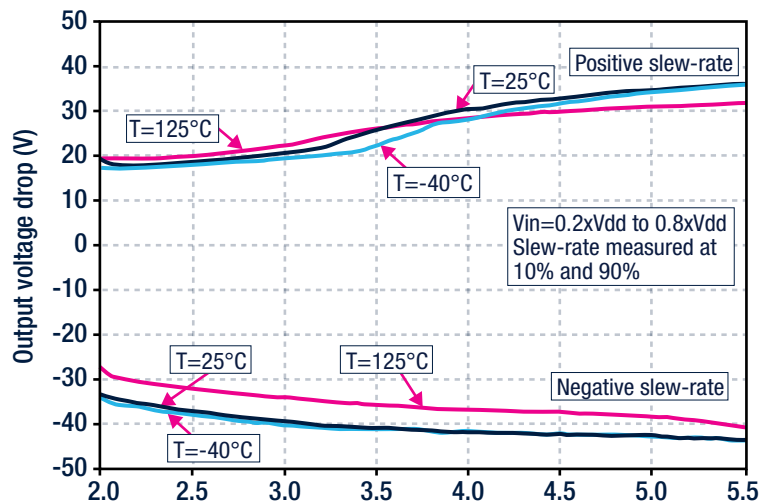

Fast operational amplifiers

Part number	Typ. GBP (MHz)	Typ. SR (V/ μ s)	Min. V_{CC} (V)	Max. V_{CC} (V)	Typ. I_{CC} per channel (mA)	Max. V_{IO} @ 25 °C (μ V)	Typ. 1 kHz noise (nV/ \sqrt Hz)	Typ. I_{OUT} (mA)	Rail to rail		Package Single	Package Dual	Package Quad
									In	Out			
TS922A/4A	4	1.3	2.7	12	1	900	9	80	Yes	Yes	NA	S08, TSSOP8	S014, TSSOP14
TL071/2/4	4	16	6	36	1.4	3 000	15	40	No	No	S08	S08	S014
TSB511/12/14	6	3	2.7	36	1.8	1500	12	50	Yes	Yes	SOT23-5	S08, Mini-S08	S014, TSSOP14
TSB711A/12A	6	3	2.7	36	1.8	300	12	50	Yes	Yes	SOT23-5	S08, Mini-S08	NA
TSV911A/2A/4A	8	4.5	2.5	5.5	0.78	1 500	27	35	Yes	Yes	SOT23-5, S08	S08, Mini-S08	S014, TSSOP14
TSX7191/2	8.5	2.4	2.7	16	0.66	200	22	70	Yes	Yes	SOT23-5		NA
TSX921/2	10	17.2	4	16	2.8	4 000	16.5	62	Yes	Yes			S08, TSSOP8, DFN8 (3x3)
TS971/2/4	12	4	2.7	10	2	5 000	4	100	No	Yes	NA	S08	S014
MC33078/9	15	7	5	30	2	2 000	4.5	30	No	No	NA	S08	S014
TSX9291/2	16	26	4	16	2.8	4 000	16.5	62	Yes	Yes	SOT23-5	S08, Mini-S08	NA
TSV991A/2A/4A	20	10	2.5	5.5	0.82	1 500	27	35	Yes	Yes	SOT23-5	S08, Mini-S08	S014, TSSOP14
TSV772	20	13	2.0	5.5	1.9	200	7	65	Yes	Yes	NA	S08, Mini-S08	NA
TSB7191A/92A	22	12	2.7	36	1.8	300	12	50	Yes	Yes	SOT23-5	S08, Mini-S08	NA
TSV7721/2	22	11	1.8	5.5	1.7	200	13	65	No	Yes	SOT23-5	S08, Mini-S08	NA
TSV791/2	50	30	2.2	5.5	5.5	200	6.5	60	Yes	Yes	SOT23-5	S08, Mini-S08	NA
TSH80/2	65	115	4.5	12	8.2	10 000	11	55	No	Yes	SOT23-5, S08	S08	NA



COMPARATORS

TSX3702/4: Micropower (5 μ A) 16 V dual/quad CMOS comparator with push-pull output

The TSX3702 and TSX3704 are micropower CMOS dual and quad voltage comparators which exhibit a very low current consumption of 5 μ A (typ.) per comparator. Improving on the TS370, these devices show a lower current consumption, a better input offset voltage, and an enhanced ESD tolerance. The TSX3702 and TSX3704 are fully specified over a wide temperature range and are available in automotive grade for the TSSOP14 and SO8 packages. They are fully compatible with the TS3702 & TS3704 CMOS comparators and are available with similar packages.

Propagation delay vs supply voltage, overdrive = 100 mV

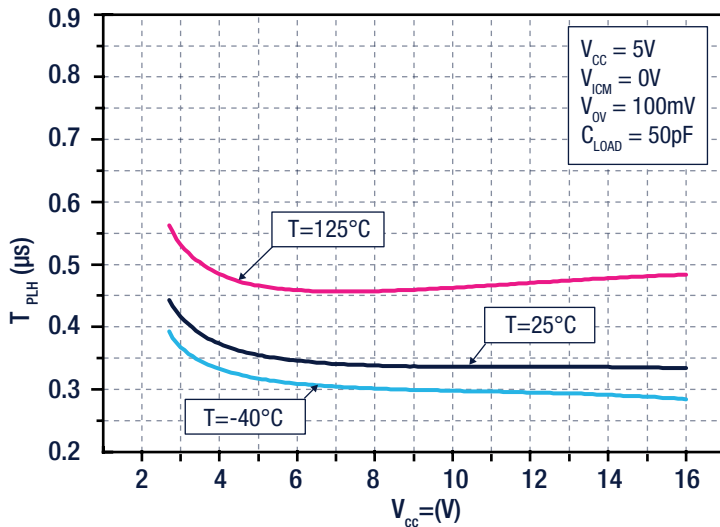

Propagation delay vs input signal overdrive @ $V_{CC} = 5V$

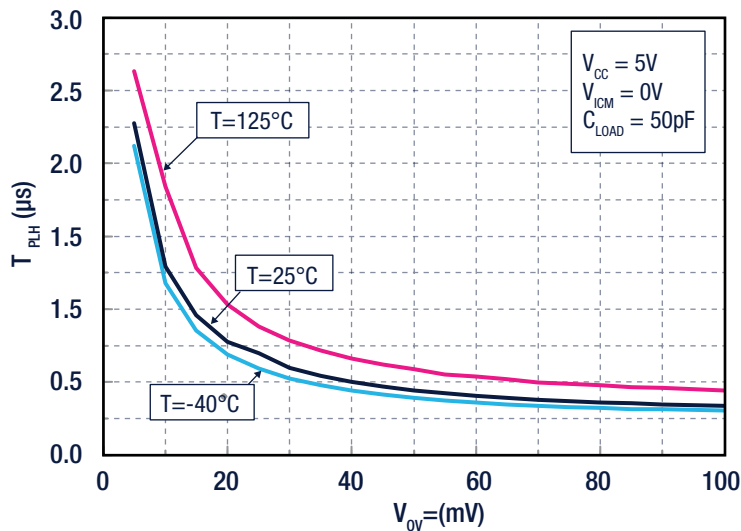

FEATURES

- Low supply current: 5 μ A (typ.) per comparator
- Wide single supply range: 2.7 to 16 V or dual supplies (± 1.35 to ± 8 V)
- Extremely low input bias current: 1 pA (typ.)
- Input common-mode voltage range includes ground
- Push-pull output
- High input impedance: $10^{12} \Omega$ (typ.)
- Fast response time: 2.7 μs (typ.) for 5 mV overdrive
- ESD tolerance: 4 kV (HBM), 200 V (MM)



Comparators

Part number	Typ. ICC per channel (μ A)	Min. V_{CC} (V)	Max. V_{CC} (V)	Typ. response time (ns) 100 mV	Rail to rail In	Output type	Input type	Package Single	Package Dual	Package Quad
TS3011	470	2.2	5	8	Yes	Push-pull	CMOS	SOT23-5, DFN8 (2x2 WF)	NA	
TS3021/2	73	1.8	5	42	Yes	Push-pull	BIP	SOT23-5	S08, MiniS08	NA
TS331/2/4	20	1.6	5	270	Yes	Open drain		SOT23-5	S08	S014, TSSOP14
TS391	200	2	36	300	GND	Open collector		SOT23-5, DFN8 (2x2 WF)	NA	
TSX3702/4	5	2.7	16	340	GND	Push-pull	CMOS	NA	S08	TSSOP14
TSX393/339	5	2.7	16	550	GND	Open drain				
LM2901/3	200	2	32	1 300	GND	Open collector	BIP		S08, TSSOP8, MiniS08, DFN8 (2x2 WF)	S014, TSSOP14
LM2903W	200	2	36	1300	GND	Open collector	BIP		S08, TSSOP8	NA
TS393	9	2.7	16	1 500	GND	Open drain	CMOS		S08	NA
TS882	0	1.1	6	2 600	Yes	Push-pull			MiniS08	

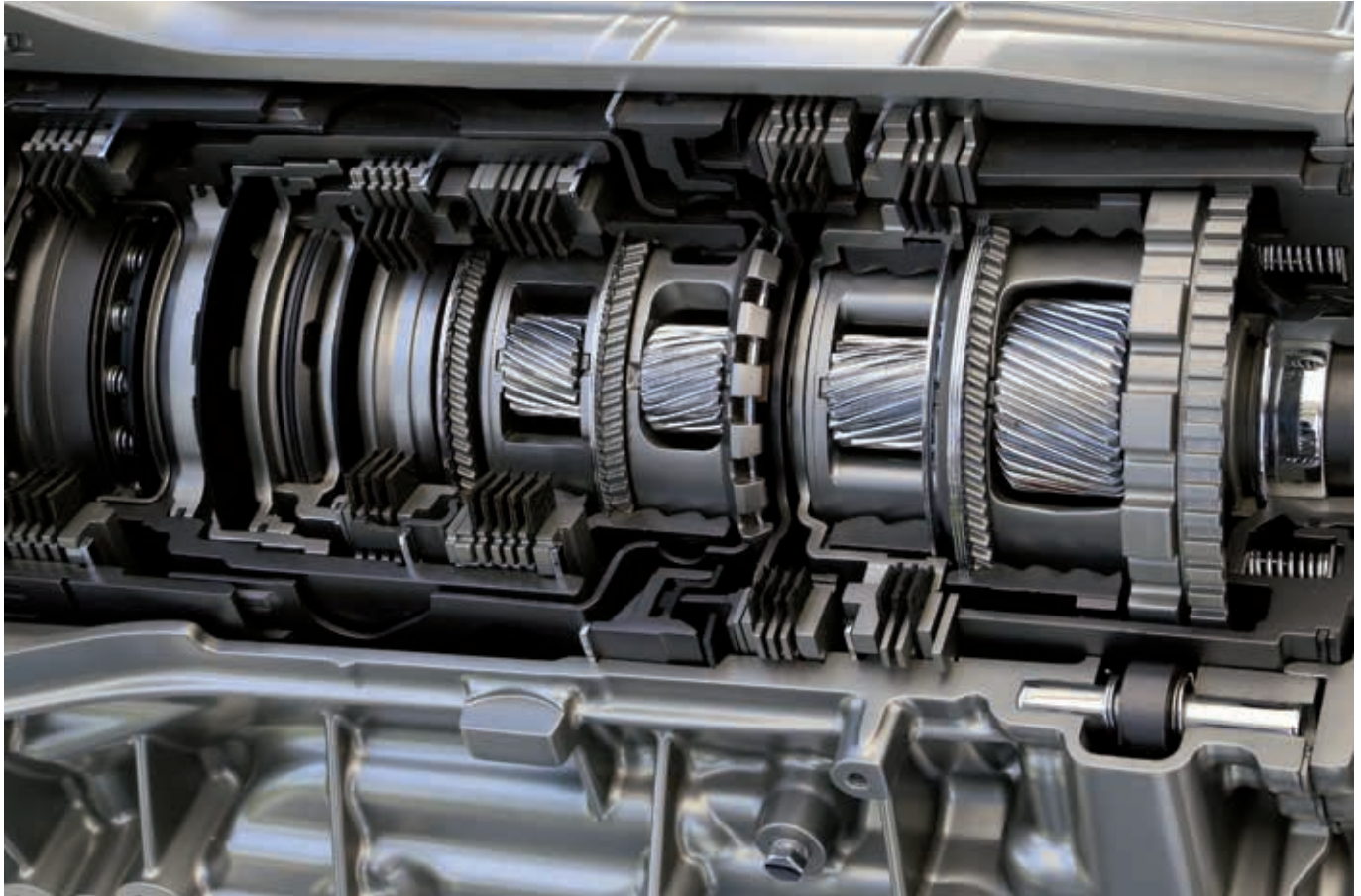

GRADE 0 (150 °C) AMPLIFIERS AND COMPARATORS

TSZ181H/TSZ182H: automotive-grade, very high accuracy (25 μV), high bandwidth (3 MHz), high temperature (150 °C), zero-drift operational amplifiers

The TSZ181H and TSZ182H are a single and dual operational amplifier, featuring very low offset voltages with virtually zero-drift versus temperature changes. The TSZ181H and TSZ182H offer rail-to-rail input and output, excellent speed/power consumption ratio, and 3 MHz gain bandwidth product, while consuming just 1 mA at 5 V. The device operates over an extended range of -40 to +150°C and features an ultra-low input bias current. These features make the TSZ181H and TSZ182H ideal for high-accuracy high-bandwidth sensor interfaces for automotive environment.

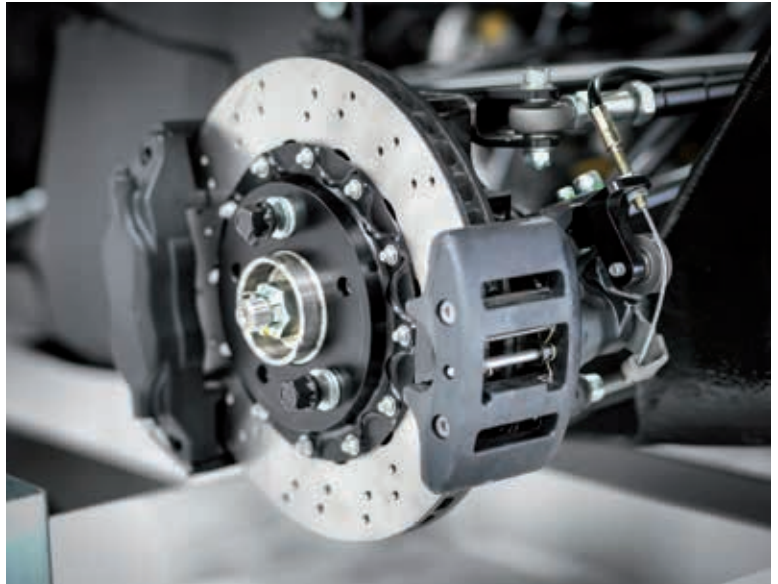

Input offset voltage distribution at $V_{CC} = 5\text{ V}$, $T = 150\text{ }^\circ\text{C}$

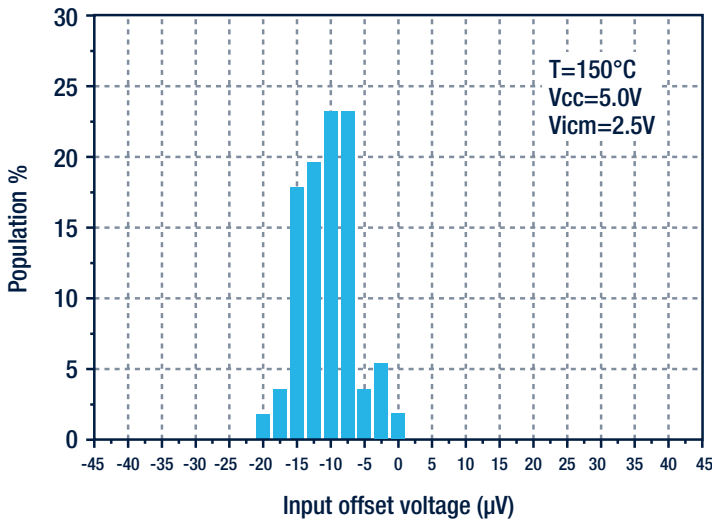

FEATURES

- AEC-Q100 qualified
- Very high accuracy and stability:
 - 25 μV max. offset voltage at 25 °C
 - 44 μV offset voltage over full temperature range
- Rail-to-rail input and output
- Low supply voltage: 2.2 - 5.5 V
- Low power consumption: 1 mA max. at 5 V
- Gain bandwidth product: 3 MHz
- Extended temperature range: -40 to 150 °C
- Micropackage: SOT23-5, S08

Input offset voltage vs temperature

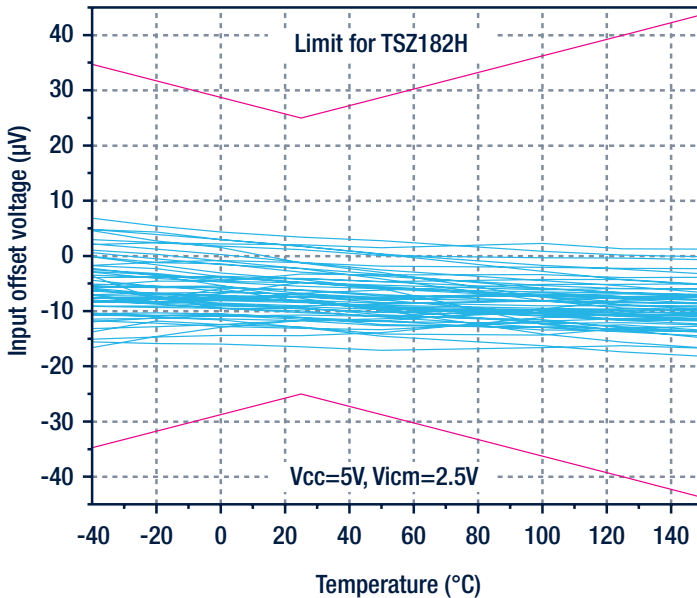

High-temperature amplifiers

Part number	Max. operating Temperature (°C)	Typ. GBP (MHz)	Typ. SR (V/μs)	Min. V _{cc} (V)	Max. V _{cc} (V)	Typ. I _{cc} per channel (mA)	Rail to rail		Package Single	Package Dual
							In	Out		
LM2904AH/WH	150	1.1	0.6	3	30	0.5	GND	No	NA	TSSOP8, S08, Mini-S08
TSV912H	150	8	4.5	2.5	5.5	0.82	Yes	Yes	NA	S08
TSZ181H/2H	150	3	4.7	2.2	5.5	0.70	Yes	Yes	SOT23-5	S08
TSZ182H1	175	3	4.7	2.2	5.5	0.70	Yes	Yes	NA	S08

High-temperature comparators

Part number	Max. operating Temperature (°C)	Typ. I _{cc} per channel (μA)	Min. V _{cc} (V)	Max. V _{cc} (V)	Typ. response time (ns) 100 mV overdrive	Rail to rail In	Output type	Package Single	Package Dual	Package Quad
TS3021H	150	73	1.8	5	42	Yes	Push-pull	SOT23-5	NA	NA
LM2901H/3H	150	200	2	36	300	GND	Open collector	NA	S08, TSSOP8	S014
LM2903WH	150	200	2	36	500	GND	Open collector	NA	S08, MiniS08	NA

MAIN APPLICATIONS



Engine control



In-gearbox modules



Safety-critical systems



Brakes



Current-sense amplifiers

TSC2011: high-voltage, precision, bidirectional current-sense amplifier

A precision bidirectional current sense amplifier, the TSC2011 can sense the current thanks to a shunt resistor over a wide range of common mode voltages, from -20 to +70 V, regardless of the supply voltage. It is available with an amplifier gain of 60 V/V.

It is able to sense very low drop voltages as low as 10 mV full scale minimizing the measurement error.

The TSC2011 can also be used in other functions including precision current measurement, overcurrent protection, current monitoring, and feedback loops.

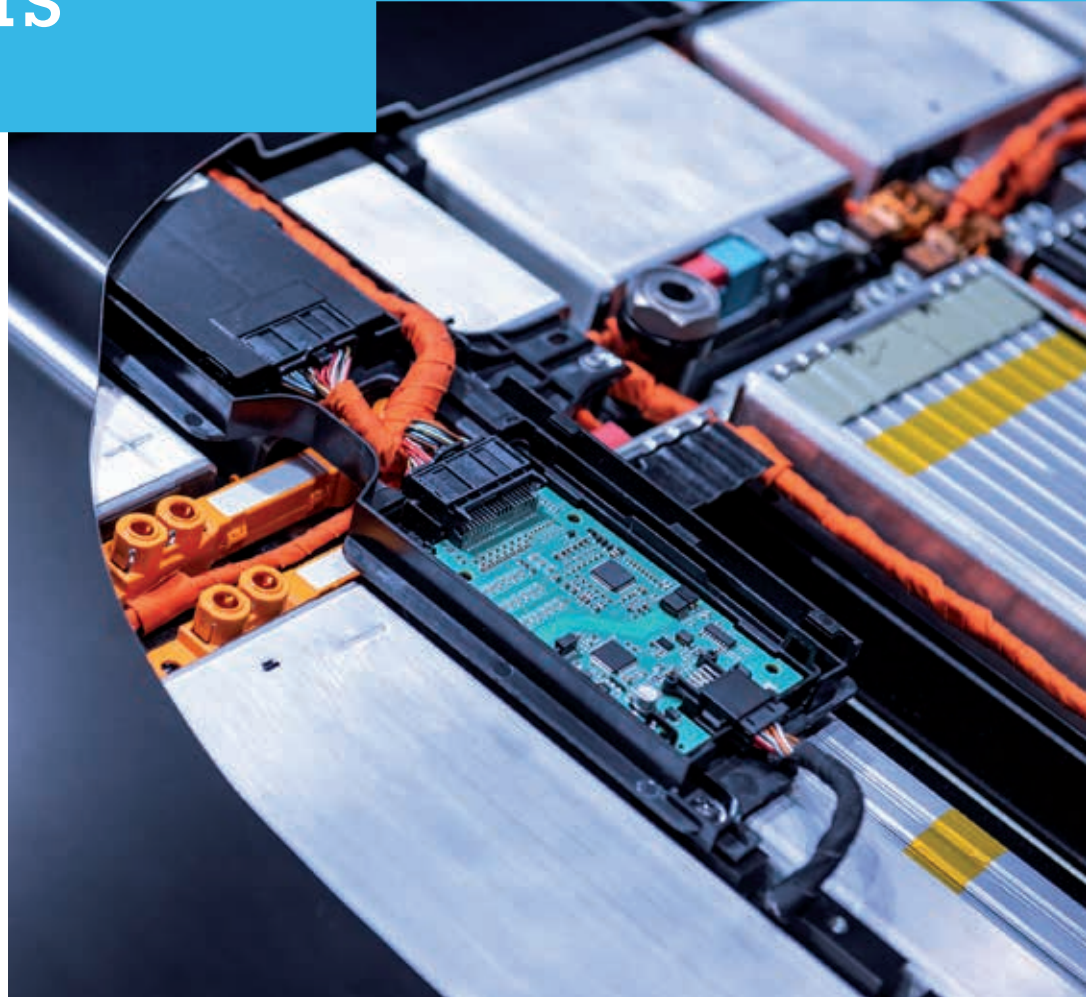

TSC2011 block diagram

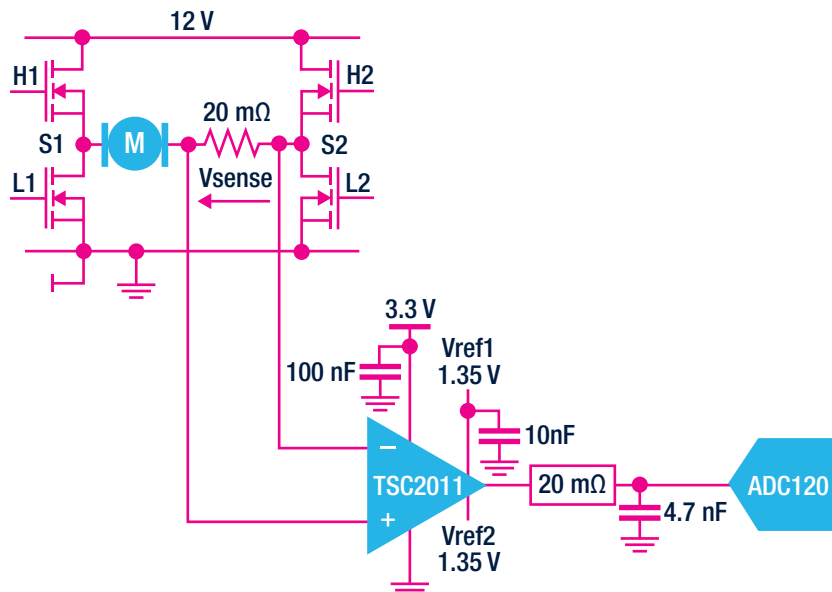

FEATURES

- Wide common mode voltage: 20 to 70 V
- Offset voltage: $\pm 200 \mu\text{V}$ (maximum)
- 2.7 to 5.5 V supply voltage
- Gain: 60 V/V
- Gain error: 0.3% (maximum)
- Offset drift: $5 \mu\text{V}/^\circ\text{C}$ (maximum)
- Gain drift: $10 \text{ ppm}/^\circ\text{C}$ (maximum)
- Quiescent current: $20 \mu\text{A}$ in
- Shutdown mode
- S08 and Mini-S08 package

Current-sense amplifiers

Part number	Type	Max. I_{CC} (μ A)	Common mode operating range (V)		V_{CC} (V)		Voltage gain (V/V)	Operating temperature ($^{\circ}$ C)		Package
			Min	Max	Min	Max		Min	Max	
Hide-side current sensing										
TSC101	Unidirectional	300	2.8	30	4	24	20, 50, 100	-40	+125	SOT23-5
TSC102	Unidirectional	420	2.8	30	3.5	5.5	20	-40	+125	TSSOP8, S08
TSC1021	Unidirectional	300	2.8	30	3.5	5.5	20, 50	-40	+125	TSSOP8
TSC103	Unidirectional	360	2.9	70	2.7	5.5	20, 25, 50, 100	-40	+125	TSSOP8, S08
TSC1031	Unidirectional	360	2.9	70	2.7	5.5	50, 100	-40	+125	TSSOP8, S08
TSC2010/2011/2012	Bidirectional	1500	-20	70	2.7	5.5	20, 60, 100	-40	+125	Mini-S08, S08
TSC210/211/212/213/214/215	Bidirectional	100	-0.3	26	2.7	26	200, 500, 1000, 50, 100, 75	-40	+125	QFN10 (1.8x1.4 WF) ⁽¹⁾ , SC70-6

⁽¹⁾ Product under development

High temperature current sense amplifiers

Part number	Type	Max. I_{CC} (μ A)	Common mode operating range (V)		V_{CC} (V)		Voltage gain (V/V)	Operating temperature ($^{\circ}$ C)		Package
			Min	Max	Min	Max		Min	Max	
TSC2010H/2011H/2012H	Bidirectional	1500	-20	70	2.7	5.5	20, 60, 100	-40	+150	S08

Evaluation boards

Part number	Description	Documentation Ref.
STEVAL-ISQ007V1	High-side current-sense amplifier demonstration board based on TSC101	AN2727
STEVAL-ISQ010V1	High-side current-sense amplifier demonstration board based on TSC102	DB0982
STEVAL-ISQ013V1	Low-side current sensing based on TS507	AN3222
STEVAL-ISQ014V1	Low-side current sensing based on TSZ121	UM1737
STEVAL-AETKT1V2	High-side current-sense amplifier demonstration board based on TSC2010/2011/2012	DB4135
STEVAL-AETKT2V1	Evaluation kit for high precision bidirectional current sense amplifiers	DB4471

DC-DC converters

DC-DC CONVERSION FROM CAR/TRUCK BATTERY - ASYNCHRONOUS ICs

A7987: 61 V, 3 A step-down switching regulator with adjustable current limitation for automotive

The A7987 is a step-down monolithic switching regulator that can deliver up to 3 A DC. The adjustable output voltage ranges from 0.8 V to V_{IN} . The wide input voltage range and the almost 100% duty cycle capability meet the fail-safe specifications for automotive systems. The embedded switch-over feature on the VBIAS pin maximizes efficiency at light load. The adjustable current limitation, designed to select the inductor RMS current in accordance with the nominal output current, and the high switching frequency capability make the size of the application compact. Pulse-by-pulse current sensing with digital frequency fold-back implements an effective constant current protection over the different application conditions. The peak current fold-back decreases the stress of the power components in heavy short-circuit conditions. The PGOOD open collector output can also implement the output voltage sequencing during the power-up phase. Multiple devices can be synchronized by sharing the SYNCH pin to prevent beating noise for low noise requirements such as in infotainment applications.



FEATURES

- 3 A DC output current
- 4.5 to 61 V operating input voltage
- Adjustable f_{sw} (250 kHz to 1.5 MHz)
- Output voltage adjustable from 0.8 V to V_{IN}
- Synchronization
- Adjustable soft-start time
- Adjustable current limitation
- VBIAS improves efficiency at light load
- PGOOD open collector output
- Digital frequency fold-back in short-circuit
- Auto recovery thermal shutdown
- Qualified in compliance with AEC-Q100 requirements



A7987 application schematic

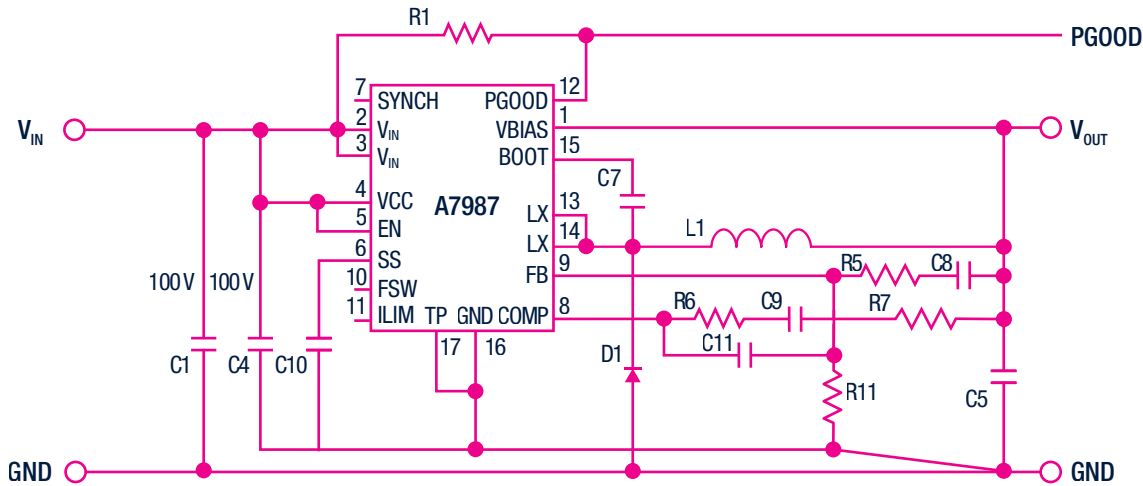

DC-DC conversion from car/truck battery - asynchronous ICs

Part number	V _{IN} (V)	V _{OUT} (V)	I _{OUT} (A)	Frequency	Other features	Package	Application
A5970AD	4 to 36	Adj. (1.235 to V _{IN})	1	500 kHz	Synchronization, V _{REF}	S08	Conversion from car battery
A5970D		Adj. (1.235 to V _{IN})	1	250 kHz	Synchronization, V _{REF}	S08	
A5972D		Adj. (1.235 to V _{IN})	1.5	250 kHz	Synchronization, V _{REF}	S08	
A5973AD		Adj. (1.235 to V _{IN})	1.5	500 kHz	Synchronization, V _{REF}	HSOP8	
A5973D		Adj. (1.235 to 35)	2	250 kHz	Synchronization, V _{REF}	HSOP8	
A5974AD		Adj. (1.235 to 35)	2	500 kHz	Synchronization, V _{REF}	HSOP8	
A5974D		Adj. (1.235 to 35)	2.5	250 kHz	Synchronization, V _{REF}	HSOP8	
A5975AD		Adj. (1.235 to 35)	2.5	500 kHz	Synchronization, V _{REF}	HSOP8	
A5975D		Adj. (1.235 to 35)	3	250 kHz	Synchronization, V _{REF}	HSOP8	
A6902D		8 to 36	Adj. (1.235 to 35)	1	250 kHz	Synchronization, V _{REF} constant current with HS Sense	
A7985A	4.5 to 38	Adj. (0.6 to 38)	2	250 kHz to 1 MHz	Synchronization, adj. f _{SWP} Internal Soft-Start	HSOP8	
A7986A		Adj. (0.6 to 38)	3	250 kHz to 1 MHz	Synchronization, adj. f _{SWP} Internal Soft-Start	HSOP8	
A7987	4.5 to 61	Adj. (0.8 to V _{IN})	3	250 kHz to 1.5 MHz	Synchronization, adj. f _{SWP} Power Good signal, adj. Soft-Start, adj. current limit	HTSSOP16	

Evaluation boards

Part number	Description	Documentation Ref.
STEVAL-ISA088V1	1 A step down switching regulator (V _{IN} = 4 to 36 V, V _{OUT} = 1.235 V to V _{IN}) based on A5970D	DB1265
STEVAL-ISA089V1	1.5 A step down switching regulator (V _{IN} = 4 to 36 V, V _{OUT} = 1.235 V to V _{IN}) based on A5972D	DB1267
STEVAL-ISA098V1	2 A step-down switching demonstration board based on the A7985A in HSOP8 package	DB1621
STEVAL-ISA100V1	3 A step-down switching demonstration board based on the A7986A in HSOP8 package	DB1623
STEVAL-ISA101V1	2 A DC step-down switching regulator with 4 to 36 V input voltage range based on the A5973D	DB1663
STEVAL-ISA106V1	1.5 A step-down switching regulator based on the A5973AD	DB1716
STEVAL-ISA152V1	3.3 V / 3 A high efficiency step down DC-DC converter (V _{IN} = 4.5 to 60 V) based on the A7987	DB2108
STEVAL-ISA155V1	1 A constant current battery charger evaluation board based on the A6902D	DB2340
STEVAL-ISA198V1	2 A step down DC - DC switching regulator (V _{IN} = 4.5 to 60 V) based on the A7987L	DB3109
STEVAL-ISA207V1	3 A step down DC/DC switching regulator (V _{IN} = 4.5V to 60 V) based on the A7987	DB3887

DC-DC CONVERSION FROM CAR BATTERY - SYNCHRONOUS ICs

A6985F, A6986F, A6986 and A6983^(*): 38 V input voltage and 0.5, 1.5, 2, 3 A output current step down switching regulators.

The A6985F, A6986F, A6986 and A6983^(*) are step-down monolithic converters with synchronous rectification capable of 0.5, 1.5, 2 A and 3A output current respectively. Concerning A6985F/6F/6, follow are reported some features description. The output voltage adjustability ranges from 0.85 V to V_{IN} . The PMOS high side allows for true 100% duty cycle capability and the wide input voltage range meet the cold crank and load dump needs for automotive systems. The “Low Consumption Mode” (LCM) is designed for applications active during car parking, so it maximizes the efficiency at lightload with controlled output voltage ripple. The “Low Noise Mode” (LNM) makes the switching frequency constant and minimizes the output voltage ripple overload current range, meeting low-noise requirements for applications such as car audio systems. The output voltage supervisor manages the reset phase for any digital load (MCU, FPGA). The RST open collector output can also implement output voltage sequencing during the power-up phase. The synchronous rectification, designed for high efficiency at medium to heavy loads, and the high switching frequency capability make the size of the application compact. Pulse-by-pulse current sensing on both power elements implements an effective constant current protection. The thermally performant HTSSOP 16 package allows for a typical junction to ambient resistance of 40 °C/W.

^(*) Product under development

FEATURES

- Input voltage: 4 to 38 V
- Output voltage: Fixed output voltage : 3.3 and 5 V or adjustable from 0.85 V to V_{IN}
- Output current:
 - 3 A for A6983
 - 2 A for the A6986
 - 1.5 A for the A6986F
 - 0.5 A for the A6985F
- Adjustable switching frequency + Sync capability:
 - 250 kHz - 2 MHz for A6985F/6F/6
 - 250 kHz - 2.2 MHz for A6983^(*)
- Synchronous rectification
- PMOS high-side for 100 % duty cycle
- Low minimum ton (80 ns for A6985F/6F/6)
- Dynamically adjustable skip current level in LCM (A6985F/6F/6)
- Low consumption mode or Low noise mode:
 - $I_Q=30\mu A$ for A6985F/6F/6
 - $I_Q=17\mu A$ for A6983^(*)
- Inhibit & low shut-down current (8 μA)
- Power Good with adj delay (embedded voltage supervisor to reset MCU) for A6985F/6F/6
- Adjustable soft start
- VBIAS to improve efficiency at light loads
- Ceramic COUT allowed
- Spread spectrum for A6983^(*)
- Over-current, over-voltage, and thermal protections
- Packages:
 - HTSSOP16 for A6985F/6F/6
 - QFN16 (3x3 WF) for A6983^(*)



Typical A6986F application diagram

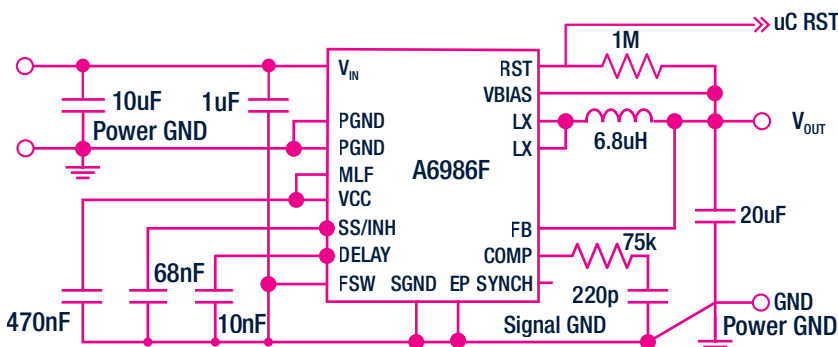

Efficiency curves $V_{IN} = 24\text{ V} - V_{OUT} = 5\text{ V}$ fsw=500 kHz for A6986F

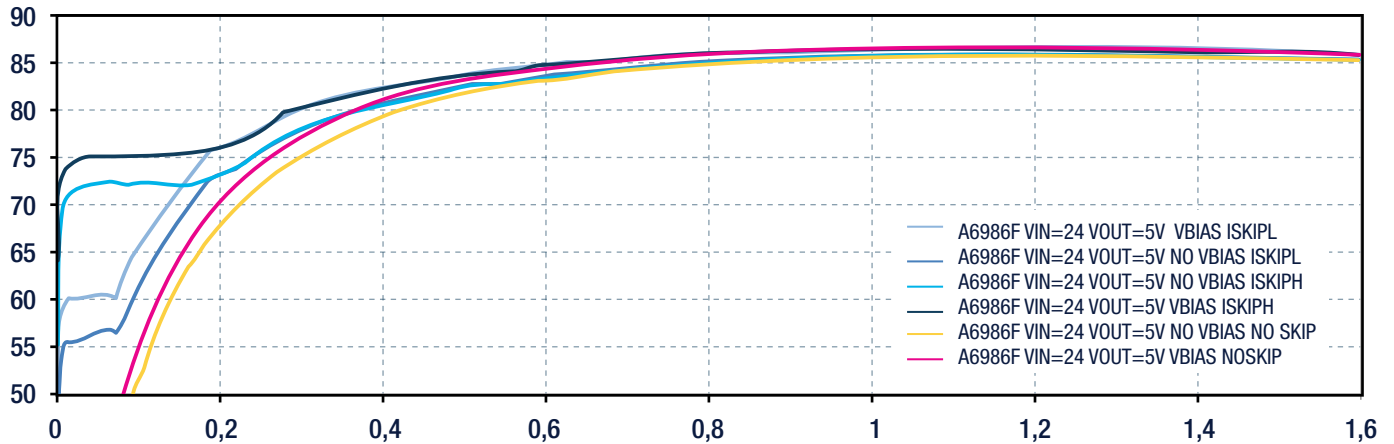

FEATURES

- Designed for isolated buck topology
- Up to 38V operating input voltage
- Primary output voltage regulation / no optocoupler required
- Output current capability at primary side:
 - 3 A for A6983I (*)
 - 2 A for A6986I
- Peak current mode architecture in forced PWM operation
- 300 ns blanking time
- 8 uA Iq-shutdown (A6986I)
- Adjustable switching frequency and synchronization
- Spread spectrum for improved EMC, A6983I(*)
- Embedded primary output voltage supervisor
- Adjustable soft-start time
- Internal primary current limiting
- Overvoltage protection
- Thermal shutdown

A6986I and A6983I (*): robust synchronous isolated buck converters for isolated applications

The A6986 and A6983I (*) are automotive-grade devices specifically designed for the isolated buck topology. The 100% duty cycle capability and the wide input voltage range meet the cold crank and load dump specifications for automotive systems. The primary output voltage can be accurately adjusted, whereas the isolated secondary output is derived by using a given transformer ratio. No optocoupler is required.

The A6986I output current capability (at primary side) up to 2A allows a proper energy transfer to the secondary side as well as enables a tracked soft-start of the secondary output.

The A6983I(*) can manage at primary side Iout=3A and has the Spread spectrum feature for EMC improvement.

The A6986I and A6983I(*) are ideal for various applications present in Electric or Hybrid Vehicles, such as a gate drivers' supply either for IGBT- or SiC MOSFET-based electric traction systems, on-board charging (OBC) systems, battery management systems, and wherever an isolated single or double output supply is required.

(*) Product under development

A6986I application schematic

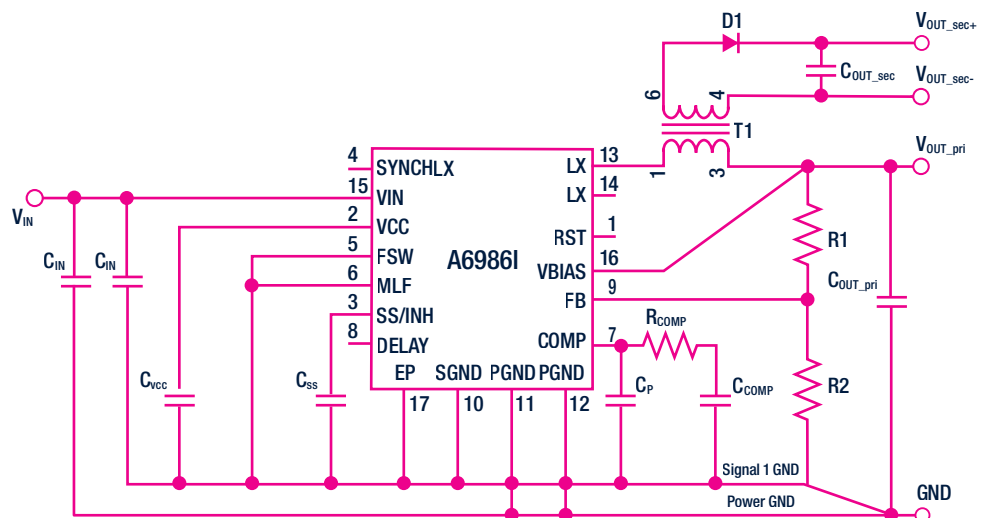

DC-DC conversion from car battery - synchronous ICs

Part number	V _{IN} (V)	I _{OUT} (A)	V _{OUT} (V)	Frequency	I _Q (μA)	Other features	Package
A6983 (*)	3.5 to 38	3	Adj. (0.85 - V _{IN})	250 kHz to 2.2 MHz	17	T _{ON} min=75ns, Adj. f _{SW} , Spread Spectrum, Synchronization, Internal Compensation, PGOOD, Low Noise or Low Consumption Mode	QFN16 (3x3 WF)
A6983I (*)	3.5 to 38	3 (*)	Adj. (0.85 - V _{IN}) (*)	250 kHz to 1.1 MHz	17	Isolated Buck, TONmin=75ns, Adj. f _{SW} , Spread Spectrum, Synchronization, Internal Compensation, PGOOD, Low Noise or Low Consumption Mode	QFN16 (3x3 WF)
A6986	4 to 38	2	Adj. (0.85 - V _{IN}) Fixed (5, 3.3)	250 kHz to 2 MHz	30	T _{ON} min=80ns, Synchronization, Adj. f _{SW} , Selectable SKIP/PWM Thsr., Adj. Soft-Start & PGOOD, Adj. Reset, Low Noise or Low Consumption Mode, OV & OC protection	HTSSOP16
A6986I	4 to 38	2 (*)	Adj. (0.85 - V _{IN}) (*)	250 kHz to 1.1 MHz	30	Isolated Buck, T _{ON} min=300ns, Synchronization, Adj. f _{SW} , Adj. Soft-Start & PGOOD, Adj. Reset, OV & OC protection	HTSSOP16
A6986F	4 to 38	1.5	Adj. (0.85 - V _{IN}) Fixed (5, 3.3)	250 kHz to 2 MHz	30	T _{ON} min=100ns, Synchronization, Adj. f _{SW} , Adj. Soft-Start & PGOOD, Adj. Reset, Low Noise or Low Consumption Mode, OV & OC protection	HTSSOP16
A6985F	4 to 38	0.5	Adj. (0.85 - V _{IN}) Fixed (5, 3.3)	250 kHz to 2 MHz	30	T _{ON} min=100ns, Synchronization, Adj. f _{SW} , Adj. Soft-Start & PGOOD, Adj. Reset, Low Noise or Low Consumption Mode, OV & OC protection	HTSSOP16
A6984	4.5 to 36	0.4	Adj. (0.9 - V _{IN})	250 kHz to 600 kHz	80	Adj. f _{SW} , Internal Soft-Start, PGOOD, Low Noise or Low Consumption Mode	VDFPN10 (4x4)

(*) Products under development

(*) Value at primary side

Evaluation boards

Part number	Description	Documentation Ref.
STEVAL-ISA158V1	38 V, 2 A synchronous step-down switching regulator evaluation board based on A6986	DB2477
STEVAL-ISA185V1	38 V, 0.5 A synchronous step-down switching regulator evaluation board based on A6985F3V3	DB2814
STEVAL-ISA186V1	38 V, 0.5 A synchronous step-down switching regulator evaluation board based on A6985F5V	DB2820
STEVAL-ISA187V1	38 V, 0.5 A synchronous step-down switching regulator evaluation board based on A6985F	DB2823
STEVAL-ISA188V1	38 V, 1.5 A synchronous step-down switching regulator evaluation board based on A6986F3V3	DB2829
STEVAL-ISA189V1	38 V, 1.5 A synchronous step-down switching regulator evaluation board based on A6986F5V	DB2831
STEVAL-ISA190V1	38 V, 1.5 A synchronous step-down switching regulator evaluation board based on A6986F	DB2932
STEVAL-ISA200V1	High-efficiency synchronous step-down regulator based on A6984	DB3249
STEVAL-A6986IV1	38 V, 2 A synchronous step-down isolated buck regulator evaluation board based on A6986I	DB4365
STEVAL-A6986IV2	38 V, 5 W synchronous isolated buck converter evaluation board with single isolated output based on the A6986I	DB4367

DC-DC CONVERTERS FOR THE POST-REGULATION

AST1S31HF: Up to 4 V, 3 A step-down 2.3 MHz switching regulator for automotive applications

The AST1S31HF is an internally compensated 2.3 MHz fixed frequency PWM synchronous stepdown regulator. The AST1S31HF operates from 2.8 to 4 V input, while it regulates an output voltage as low as 0.8 V and up to V_{IN} . The AST1S31HF device integrates a 70 mΩ high-side switch and a 55 mΩ synchronous rectifier allowing very high efficiency with very low output voltages. The peak current mode control with internal compensation deliver a very compact solution with a minimum component count. The AST1S31HF is available in a 3 x 3 mm, 8-lead VFDFPN package.

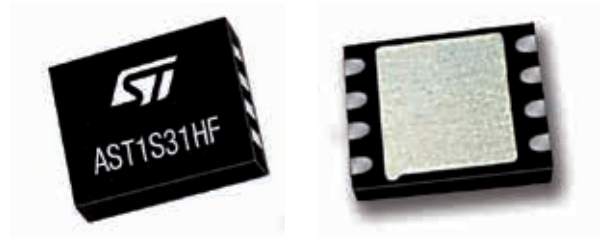

Efficiency curves $V_{IN} = 3.3\text{ V}$

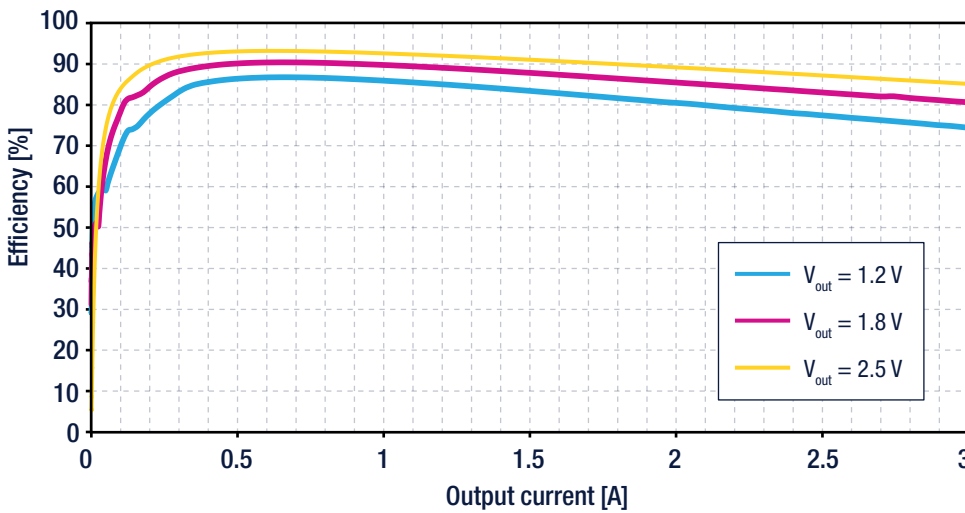

FEATURES

- Input voltage: 2.8 to 4 V
- Output voltage: 0.8 V to V_{IN}
- Output current: 3 A
- Switching frequency:
 - 1.5 MHz (AST1S31)
 - 2.3 MHz (AST1S31HF)
- Synchronous rectification
 - (HS: 60 mΩ; LS: 45 mΩ)
- Internal compensation
- Power Good signal
- Enable pin
- Internal Soft Start
- Ceramic COUT allowed
- Over-current and thermal protections
- Package: 8-lead DFN (3x3 mm)

DC-DC converters for post-regulation

Part number	V_{IN} (V)	V_{OUT} (V)	I_{OUT} (A)	Frequency	I_q	Package	Type	Other Features
AST1S31	2.8 to 4	0.8 to V_{IN}	3	1.5 MHz	630 μA	VFDFPN8 (3x3)	Monolithic synchronous converter	Internal compensation, Soft-start, Power Good
AST1S31HF	2.8 to 4	0.8 to V_{IN}	3	2.3 MHz	630 μA	VFDFPN8 (3x3)	Monolithic synchronous converter	Internal compensation, Soft-start, Power Good
A6727	1.5 to 12	0.8 to V_{IN}	Defined by the system design	300 kHz	6 mA	S08	Synchronous controller	Adj. OCB

Evaluation boards

Part number	Description	Documentation Ref.
STEVAL-ISA069V1	3 A / 1.5 MHz step-down synchronous switching regulator based on the AST1S31 in 3x3 mm DFN package	DB1572
STEVAL-ISA160V1	3 A / 2.3 MHz step-down synchronous switching regulator based on the AST1S31HF in 3x3 mm DFN package	DB2858

LED Drivers

LED ARRAY DRIVERS

ALED1262ZT: 12-channel LED driver with open detection, 7-bit local dimming brightness control, configurable bus-driven and stand-alone mode

The ALED1262ZT 12-channel LED driver for automotive rear combination lamps and interior lighting offers features which support the creation of complex and innovative visual effects.

Independent 7-bit PWM dimming on all channels allows for the flexible control of tail, brake and turn lights which produce dynamic effects. Each channel supplies a constant output current at 19 V to drive strings of LEDs in series. An adjustment of the output current between 6 and 60 mA provides a wide dimming range, and high maximum brightness.

The LED lighting driver responds to I2C commands from a host microcontroller. It provides two pre-programmed configurations which enable stand-alone operation for extra flexibility.

The ALED1262ZT gives reliable and stable operation and a long lifetime in automotive applications, offering diagnostic and protection features including open-LED detection and an over-temperature warning to trigger thermal shut-down.



INNOVATIVE FEATURES

- Fast I²C with selectable Hamming encoding
- Programmable standalone mode by OTP and Bus-driven mode via I²C
- 12-bit local dimming with non-linear steps
- Channels' gradual output delay and dithered clock for EMI reduction
- Error detection and wired OR programmable error flag

HIGH FLEXIBILITY

- I²C control interface and/or OTP programming
- Factory custom configuration by OTP

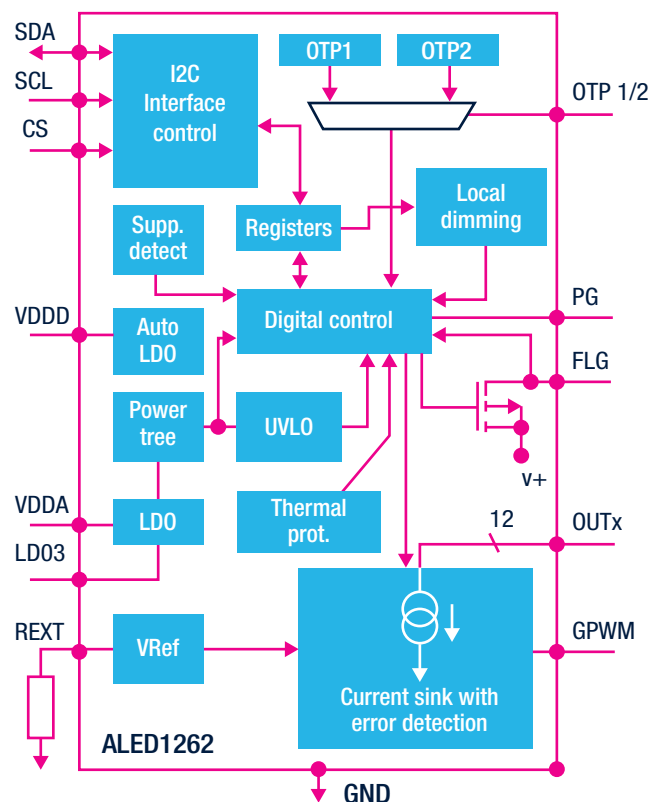
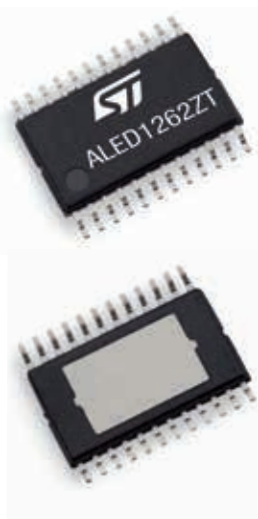

MAIN APPLICATIONS



Rear combination lights
(brake and turn signals)



Front Light DRL
(Daytime Running Light)



Interior, ambient light



Dashboard and
Infotainment backlighting

LED array drivers

Part number	Nb. of channels	LED current per channel (mA)	V _{LED} (V)	V _{IN} (V)	Special features	Auto Power saving	Package
ALED8102S	8	5 – 100	0 to 19	3 to 5.5	8 constant current output channels driven by four input control pins for local dimming, Output enable input for global dimming, adjustable output current through external resistor	No	HTSSOP16
STAP08DP05	8	5 – 100	0 to 20	3 to 5.5	Short and open output error detection, thermal shutdown protection, adjustable output current through external resistor, Serial data IN/parallel data OUT	No	HTSSOP16
ALED1262ZT	12	6 – 60	0 to 19	5.5 to 38	LEDs OPEN detection, 7-bits local dimming brightness control, I ² C interface bus-driven or stand-alone operation mode, custom configuration by OTP with Redundancy and ECC	No	HTSSOP24
ALED1642GW	16	3 – 40	0 to 20	3 to 5.5	7-bits global current gain programmability, 12/16-bits local PWM grayscale brightness control, current setting through external resistor, programmable turn on/off, auto wake-up mode, Error detection mode (both open and shorted-LEDs)	Yes	HTSSOP24
STAP16DPPS05	16	3 - 40	0 to 20	3 to 5.5	Short and open output error detection, thermal shutdown protection, adjustable output current through external resistor, Serial data IN/parallel data OUT	Yes	HTSSOP24
STAP16DPS05	16	5 – 100	0 to 20	3 to 5.5		Yes	

Evaluation boards

Part number	Description	Documentation Ref.
STEVAL-LLL002V1	LED driver for automotive rear lights with animations based on ALED1262 and STM8A	DB3472
STEVAL-ILL058V1	High-brightness LED array driver with diagnostics based on STAP08DP05 and STM8A	DB2222
STEVAL-ILL059V1	High-brightness LED array driver with diagnostics based on the STAP16DPS05 and STM8A	DB2220
STEVAL-ILL060V1	High-brightness LED array driver with diagnostics based on the STAP16DPPS05 and STM8A	ULM1774
STEVAL-ILL073V1	RGB LED driver for automotive lighting based on ALED1642GW and STM8A	UM2017
STEVAL-ILL090V1	Evaluation kit Based on ALED8102S (8 channel LED driver with direct switch control)	DB4309

STEVAL-LLL002V1: Evaluation kit for automotive rear lights with pattern animations based on ALED1262ZT and STM8AF6266

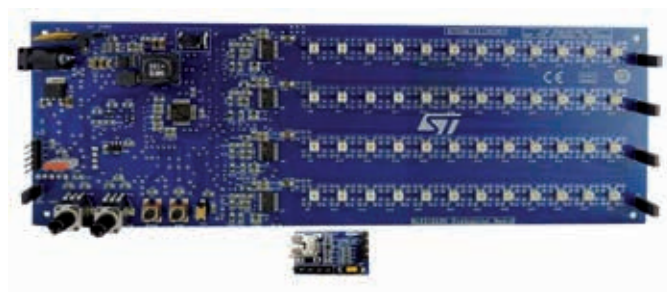

LED ROW DRIVERS

ALED7707: 6-row 85 mA LED driver with boost regulator for LCD panel backlights

The ALED7707 consists of an automotive-grade (AEC-Q100 compliant) monolithic boost converter and six controlled current generators (rows) specifically designed to supply LED arrays used in the backlighting of LCD panels. The device can manage an output voltage up to 36 V (i.e.: 10 white LEDs per row). The generators can be externally programmed to sink up to 85 mA and can be dimmed via a PWM signal (1% dimming duty cycle at 1 kHz can be managed). The device can detect and manage the open and shorted LED faults and to leave unused rows floating. Basic protections (output overvoltage, internal MOSFET overcurrent and thermal shutdown) are provided.

ALED7707 application diagram

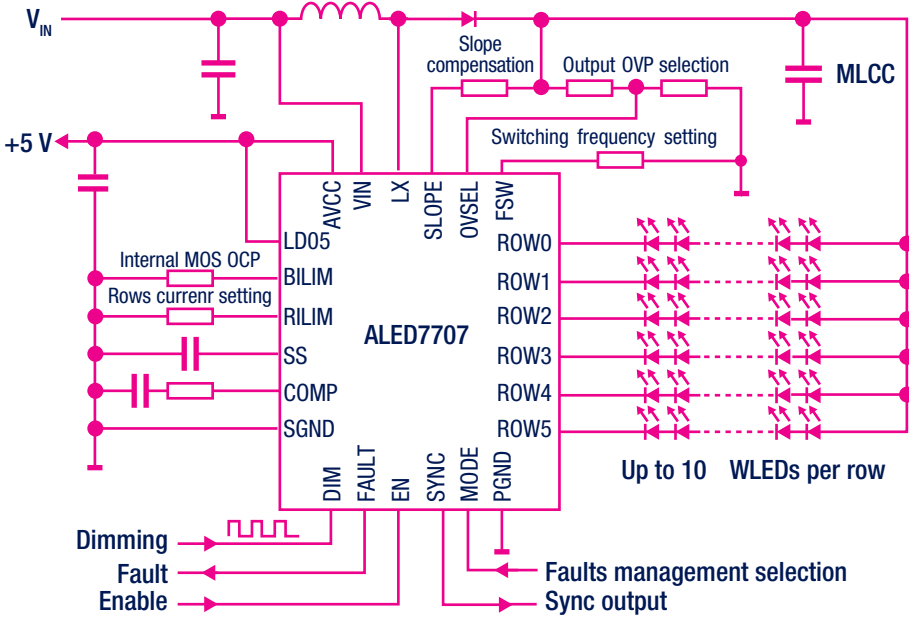

- #### FEATURES
- Rail-to-rail input and output
 - Wide supply voltage: 4 to 16 V
 - Gain bandwidth product: 16 MHz (typ.) at 16 V
 - Low power consumption: 2.8 mA (typ.) at 16 V
 - Slew rate: 27 V/μs
 - Stable when used in gain configuration
 - Low input bias current: 10 pA (typ.)
 - High tolerance to ESD: 4 kV (HBM)

MAIN APPLICATIONS



Interior, ambient light



Dashboard and Infotainment backlighting



Front Light DRL (Daytime Running Light)

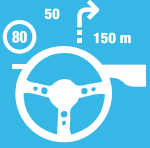

HUD (Head Up Display)

STEVAL-ILL067V1: Six-channel ALED7707-based LED driver with embedded boost converter for automotive interior lighting and TFT backlighting

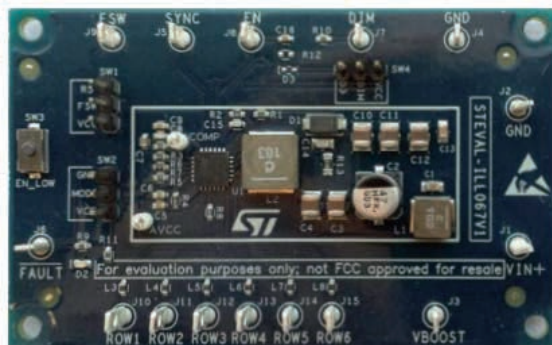



LED row drivers

Part number	Nb. of rows	Max LED current per row	Max V_{OUT} (V)	V_m (V)	Special features	Supported topology	Package
ALED6000	1	3 A	0 to 60	4.5 to 60	Adjustable f_{sw} (250 kHz - 1.5 MHz), OC and thermal protection with auto-recovery, adjustable soft-start time, dimming function with dedicated pin, adjustable current limitation, external synchronization for multi-device applications, very low shutdown current (10 μ A typ.), 3% output current accuracy over temperature	Buck	HTSSOP16
ALED6001	1	Defined by the system design	0 to 60	5.5 to 36	Adjustable f_{sw} (100 kHz - 1 MHz), PWM-dimming, very low shutdown current: ISHDN < 10 μ A, external synchronization for multi-device applications, overcurrent protection, thermal shutdown with auto restart, output short detection, LED constant current control loop	Boost, SEPIC, and floating Buck-Boost	HTSSOP16
ALED7709 ^(*)	4	200 mA	0 to 60	4 to 42	Adjustable f_{sw} (250 kHz - 2.2 MHz) with optional Spread Spectrum, mixed PWM and analog dimming, selectable channels phase-shifting and adjustable rise/fall time for reducing EMI, cycle-by-cycle power switch OCP, input OVP and output SCP, thermal shutdown LED failure (open and short-circuit) detection	Boost and SEPIC	QFN24 (5x5 WF)
ALED7707	6	85 mA	0 to 36	4.5 to 36	Adjustable f_{sw} (250 kHz - 1 MHz) External synchronization for multi-device applications, pulse skip power-saving mode at light load, programmable soft-start, programmable OVP protection, thermal shutdown, row disable option, less than 10 μ s (min.) dimming on-time, \pm 3% current matching between rows, LED failure (open and short-circuit) detection	Boost	QFN24 (5x5)

^(*) Product under development

Evaluation boards

Part number	Special features	Documentation Ref.
STEVAL-ILL048V1	Single-channel LED driver for day-time running lights (DTRL) and front lights based on ALED6001 and STM32F103C6T6	DB1900, AN4549
STEVAL-ILL049V12	LED driver based on the LED6001 + 9-LED board with NTC sensor	DB2205
STEVAL-ILL067V1	Six-channel ALED7707-based LED driver with embedded boost converter for automotive interior lighting and TFT backlighting	DB2607
STEVAL-ILL072V1	Single-channel, 1 A LED driver with boost controller for interior/exterior lights based on the ALED6001	DB2608
STEVAL-ILL089V1	1 A buck LED driver board based on the ALED6000 automotive-grade dimmable LED driver	DB4070

Linear Regulators (LDO)

LDO FOR THE CONVERSION FROM CAR BATTERY

**LDO40L: 38 V low-dropout
regulator with 45 μ A
quiescent current**

The LDO40L is a 400 mA LDO regulator designed for use in severe automotive environments. Its low quiescent current (45 μ A) makes it suitable for applications permanently connected to the car battery. This feature is especially critical when electronic modules remain in active mode when the ignition is switched off.

The LDO40L embeds protection functions, such as current limit and thermal shutdown, and is available in DFN6 (3x3 mm) with wettable flanks package.



FEATURES

- Low quiescent current: 45 μ A (typ.) at no load
- Wide input voltage operating range: 5 to 38 V
- Output current: up to 400 mA
- Output voltage options: Adj, 3.3 V, 5.0 V
- High PSRR: 73 dB @ 1 kHz
- Very low noise: 20 μ Vrms/VOUT
- Protection features: Current limitation (OCP) and thermal shutdown (OTP)
- Operating temperature range: -40 to +125 °C
- Package: DFN6 (3x3 mm with wettable flanks)



Output noise voltage vs. frequency $V_{OUT} = 5\text{ V}$

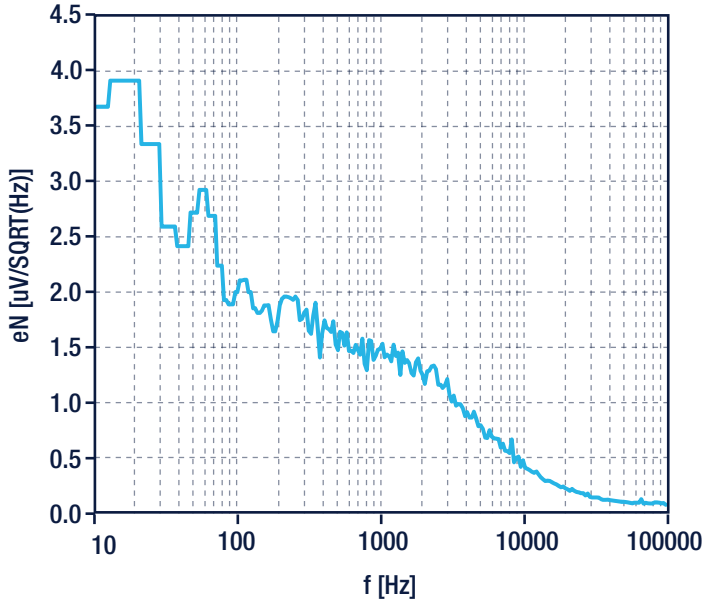

Quiescent current vs temperature

$V_{IN} = 38\text{ V}$, $I_{OUT} = 0\text{ mA}$

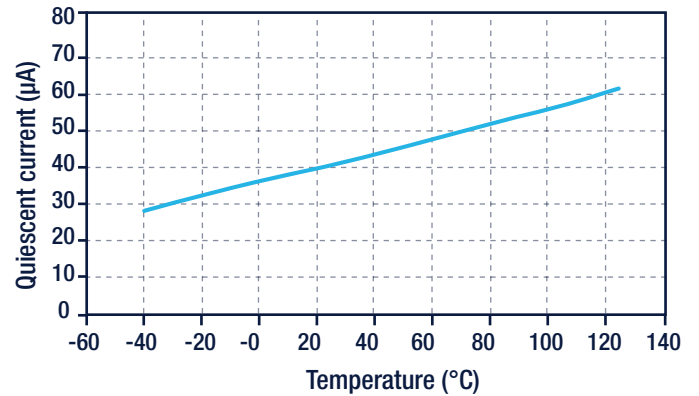

LDO40LY application diagram (fixed)

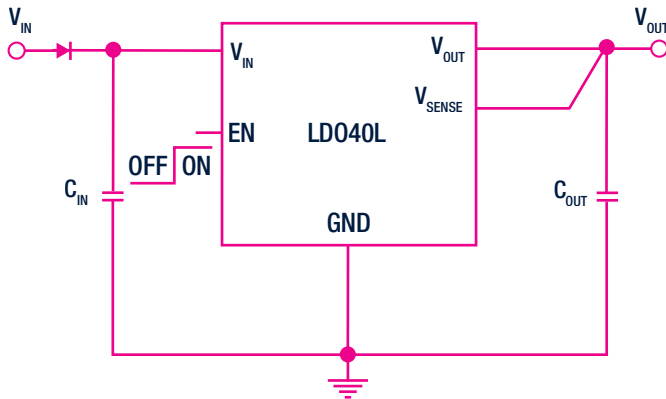

LDO40LY application diagram (adjustable)

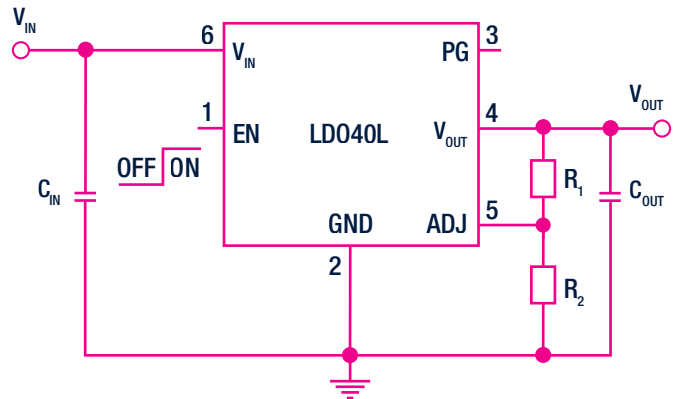

LDO for the conversion from car battery

Part number	Operating V_{IN} (V)	AMR V_{IN} (V)	V_{OUT} (V)	I_{OUT} (mA)	Drop-out voltage	I_0	PSRR @ 1 kHz (dB)	Output noise 10 Hz to 100 kHz	Other features	Package
LDQ40Y ^(*)	3.3 to 40	42	Adj (1.2 to 12) Fixed (2.5, 3.3, 5)	250	500 mV at 250 mA	2 μA	65	100 μV	Enable pin, Soft Start, PG00D, internal current and thermal protection	DFN6 (2x2 WF)
LDO40LY	3.5 to 38	40	Adj (2.5 to 11) Fixed (3.3, 5)	400	140 mV at 400 mA	45 μA	73	20 μV	Enable pin, low noise, OC and thermal protection	DFN6 (3x3 WF)
LD1086Y	2.85 to 30	30	Adj (1.25 to 24)	1500	1.3 V at 1500 mA	5 mA	68	150 μV at 5 V	1% output tolerance @ 25°C 2% tolerance full temp range, OC and thermal protection	DPAK
LFXX-TRY	2.5 to 16	40	Fixed (2.5, 3.3, 5.0, 8.0, 8.5)	500	400 mV at 500 mA	500 μA	77	50 μV	Inhibit pin, Input OV protection, OC and thermal protection	DPAK

^(*) Product under development

LDO FOR THE POST-REGULATION

LD49100: 1 A small package and low quiescent current voltage regulator for all needs

The LD49100 provides 1 A maximum current with an input voltage range from 1.5 to 5.5 V and a typical dropout voltage of 200 mV. The device is stable with ceramic capacitors on the input and output. The ultra-low dropout voltage, low quiescent current and low-noise features make it the perfect choice for secondary regulation in automotive environments. Power supply rejection is 65 dB at low frequency and starts to roll off at 10 kHz. The enable logic control function puts the LD49100 in shutdown mode, allowing a total current consumption lower than 1 μ A. The device features a tight and precise Power Good indicator, useful for monitoring and sequencing functions. Internal 1 ms soft-start circuit allows the reduction of inrush current. The device also includes short-circuit constant current limiting and thermal protection. The LD49100 is available in a DFN6 (3x3 mm) package with wettable flanks.

Output noise voltage vs. frequency

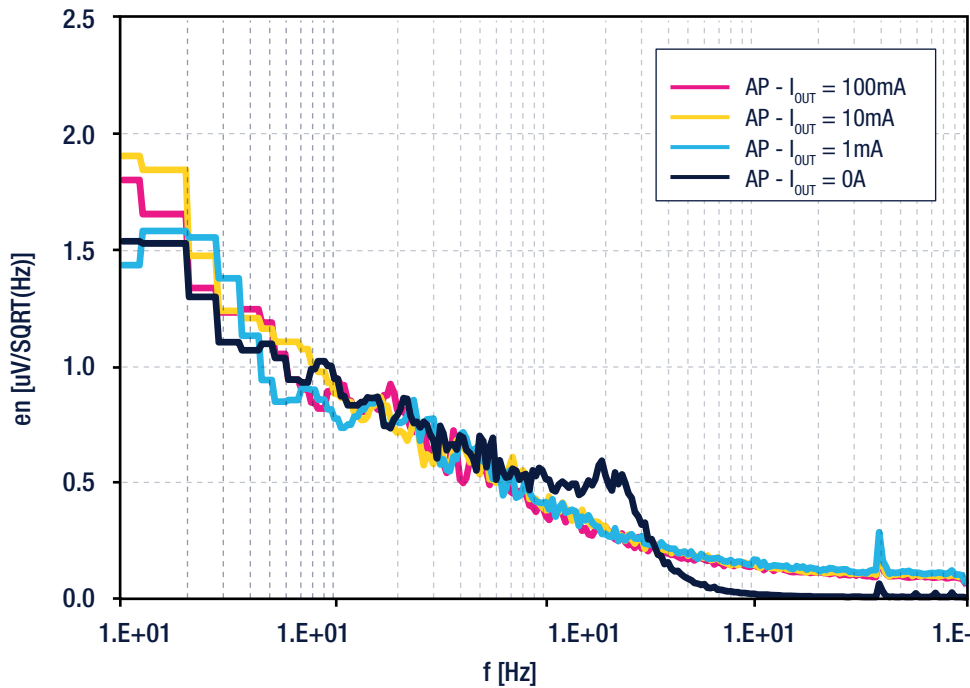

MAIN FEATURES

- Input voltage: 1.5 to 5.5 V
- 1 A guaranteed output current
- Ultra-low dropout voltage: 200 mV (typ.) at 1 A load
- Very low quiescent current: 20 μ A (typ.) at no load
- Enable, Power Good signal
- Soft Start (1 ms)
- Output voltage tolerance: $\pm 2.0\%$ at 25 $^{\circ}$ C

MAIN APPLICATIONS

- In-cabin ECU
- Infotainment/Dashboard: Cluster, Radio-Navigator, HUD, secondary displays
- ADAS: Rear and Front cameras, Radars, Sensors
- Telematics central unit

Supply voltage rejection vs freq. ($V_{OUT} = 2.5 V$)

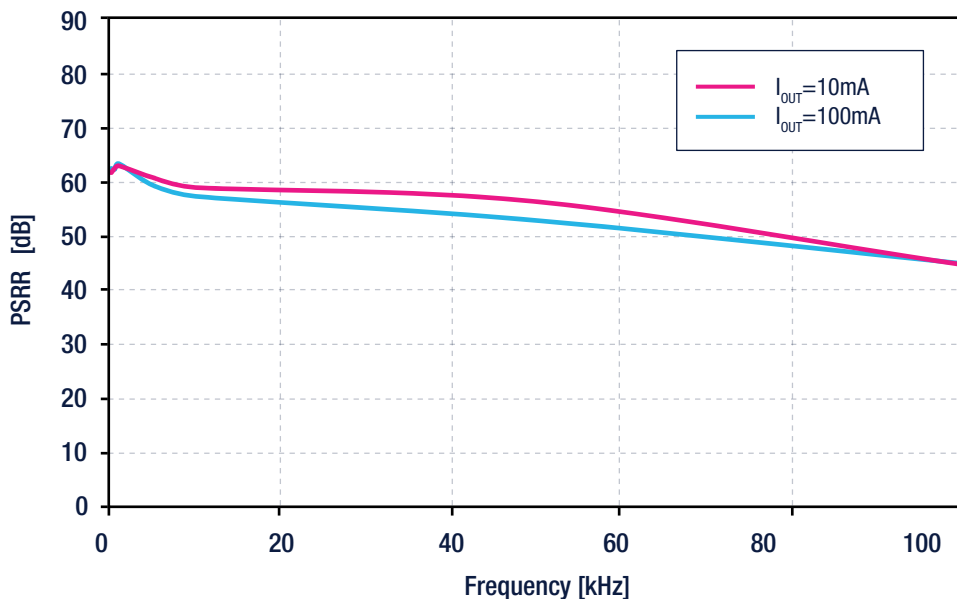

LD49100 application diagram (fixed)

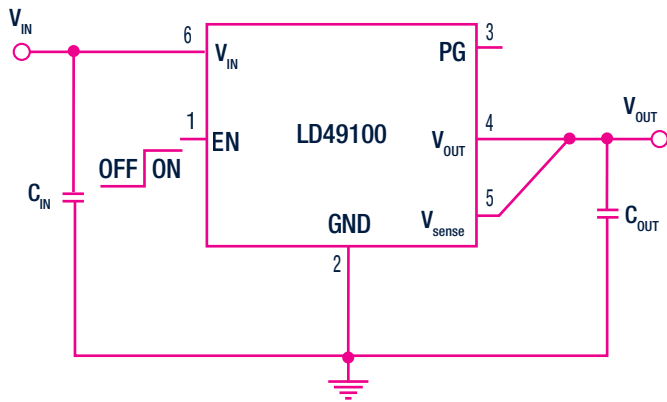

LD49100 application diagram (adjustable)

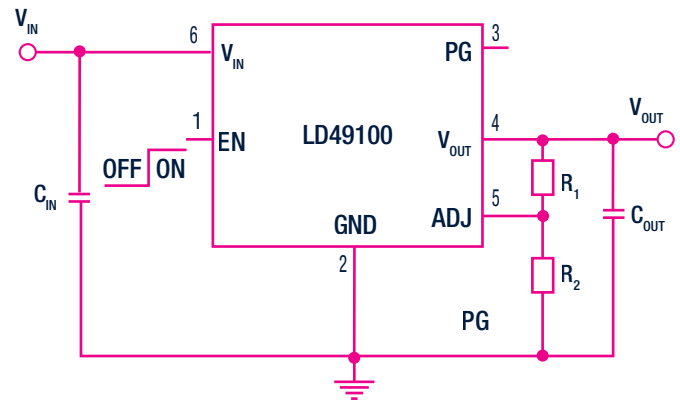

LDK130Y: 300 mA SOT-23 cost effective, low noise voltage regulator

The LDK130 low-dropout voltage regulator provides 300 mA of maximum current from an input supply voltage in the range of 1.9 to 5.5 V, with a typical dropout voltage of 100 mV. It is stabilized with a ceramic capacitor on the output.

The very low-dropout voltage, low quiescent current and low noise features make it suitable for automotive post-regulation. An enable logic control function puts the LDK130 in shutdown mode allowing a total current consumption lower than 1 μ A. The device also includes short-circuit constant current limiting and thermal protection. The SOT23-5L package is the perfect choice for a cost-sensitive applications.

Dropout voltage vs. temperature

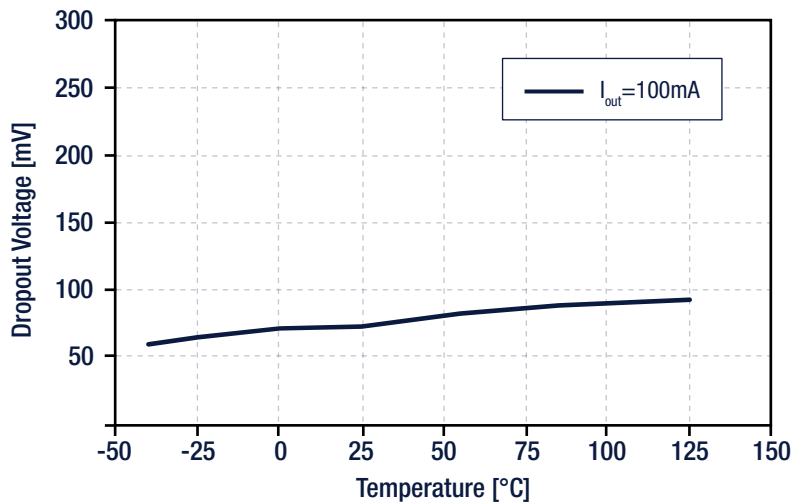

Supply voltage rejection vs freq. V_{OUT} = 2.5 V

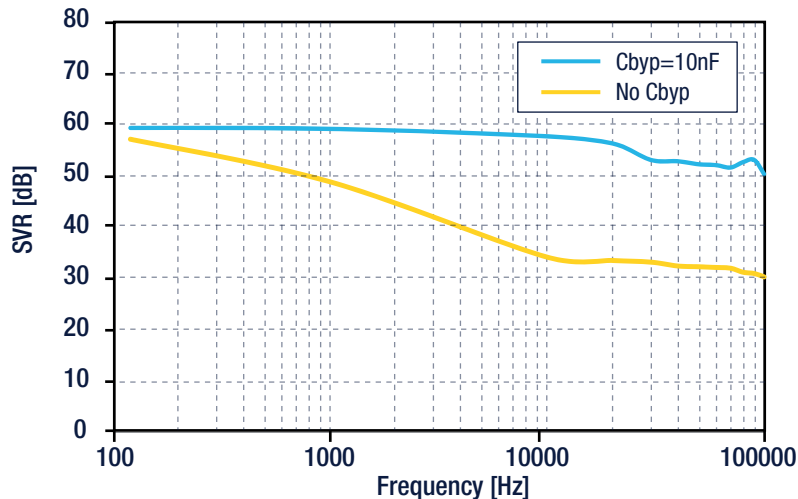

FEATURES

- Input voltage: 1.9 to 5.5 V
- Very-low dropout voltage: 100 mV (typ.) at 100 mA load
- Low quiescent current: 30 μ A (typ.) at no load, 1 μ A (max.) in off mode
- Low-noise
- Output voltage tolerance: ± 2.0 % at 25 °C
- 300 mA guaranteed output current
- Stable with ceramic capacitors (C_{OUT}) = 1 μ F
- Over Current (OC) and Thermal protection
- Package: SOT23-5L

LDK130 typical application diagram

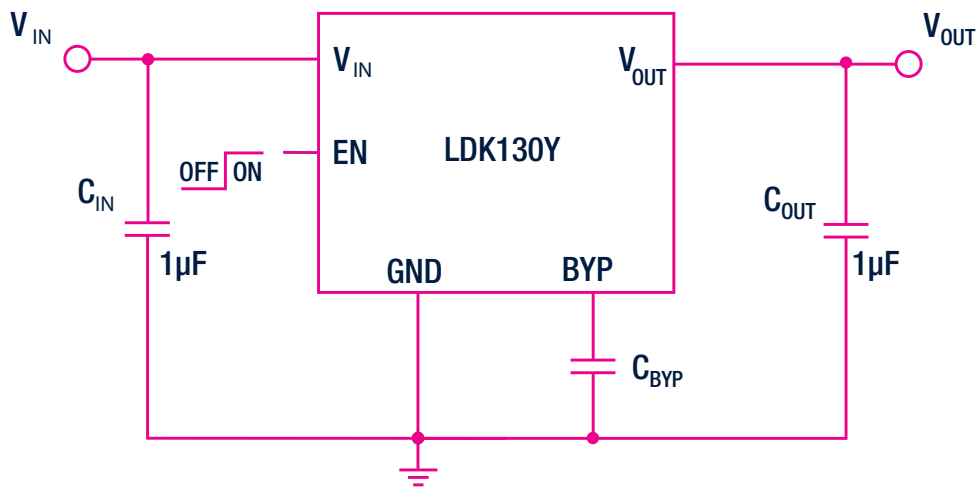

LDO for the post-regulation

Part number	Operating V_{in} (V)	AMR V_{in} (V)	V_{out} (V)	I_{out}	Drop-out voltage	I_q	PSRR @1kHz [dB]	Output noise 10 Hz-100 kHz	Other features	Package
LD1086Y	2.85 to 30	30	Adj. (1.25 to 24)	1.5 A	1.3 V at 1.5 A	5 mA	68	0.003% of V_{out}	1% output tolerance @ 25°C 2% tolerance full temp range OC and thermal protection	DPAK
LDS3985Y	2.5 to 6	6	Fixed (1.8, 3.3)	300 mA	150 mV at 300 mA	85 µA	55	30 µV	Enable, bypass for NR, OC and thermal protection	DFN6 (3x3)
LDK130Y	1.9 to 5.5	7	Fixed (1.1, 1.5, 1.8, 2.2, 2.8, 3.3)	300 mA	100 mV at 100 mA	30 µA	60	50 µV	Enable, bypass for NR, OC and thermal protection	SOT23-5L
LD39100Y	1.5 to 5.5	7	Adj. (0.8 to 4.5) Fixed (1.2, 1.8, 2.5, 3.3)	1 A	200 mV at 1 A	25 µA	70	30 µV	Enable, PGOOD, OC and thermal protection	DFN6 (3x3 WF)
LD49100Y	1.5 to 5.5	7	Adj. (0.8 to 4.5) Fixed (1.0, 1.2, 1.8, 2.5, 3.3)	1 A	200 mV at 1 A	25 µA	70	30 µV	Enable, PGOOD, soft-start, remote sensing, OC and thermal protection	DFN6 (3x3 WF)
LD59150Y	V_{in} : 0.8 to 5.5 V_{bias} : 2.7 to 5.5	6	Adj. (0.8 to 3.6)	1.5 A	65 mV at 1.5 A	1 mA	70	25 µV	Bias pin, Enable, program. soft-start, PGOOD, OC and thermal protection	DFN10 (3x3 WF)

Logic ICs

The Automotive-grade logic ICs offer a range of products including counters / encoders / decoders, gates, flip-flop / registers and buffer drivers, that fulfill all test and quality requirements for AEC-Q100 qualification in both highly reliable standard SO and TSSOP packages.



Logic ICs

Commercial Product	Function	Packages
74LCX125YMTR / 74LCX125YTTR	Quad Bus Buffer (3-State)	SO14, TSSOP14
74VHC14YMTR / 74VHC14YTTR	Hex Schmitt Inverter	SO14, TSSOP14
74LCX07YMTR / 74LCX07YTTR	Hex Buffer	SO14, TSSOP14
74LCX00YMTR / 74LCX00YTTR	Quad 2-Input NAND Gate	SO14, TSSOP14
HCF40106YM013TR	Hex Schmitt Trigger	SO14
HCF4010YM013TR	Hex Buffer/Converters non Inverting	SO16
HCF4013YM013TR	Dual D Flip-Flop	SO14
HCF4021YM013TR	8-Stage Static Shift Register	SO16
HCF4051YM013TR	Single 8-channel Analog Mux/Demux	SO16
HCF4060YM013TR	14-stage counter/Driver AND Oscillator	SO16
HCF4069YUM013TR	Hex Inverter	SO14
HCF4070YM013TR	Quad Exclusive OR Gate	SO14
HCF4093YM013TR	Quad 2-Input NAND Schmitt Trigger	SO14
HCF4094YM013TR	8-Stage Shift-AND-Store Bus Register	SO16
M74HC4851YRM13TR / M74HC4851YTTR	Single 8-channel Analog Mux/Demux	SO16, TSSOP16
M74HC4852YRM13TR	Dual 4-channel Analog Mux/Demux	SO16
M74HC04YRM13TR / M74HC04YTTR	Hex Inverter	SO14, TSSOP14
M74HC08YRM13TR / M74HC08YTTR	Quad 2-Input AND Gate	SO14, TSSOP14
M74HC126YRM13TR / M74HC126YTTR	Quad Bus Buffer (3-State)	SO14, TSSOP14
M74HC132YRM13TR / M74HC132YTTR	Quad 2-Input Schmitt NAND Gate	SO14, TSSOP14
M74HC14YRM13TR / M74HC14YTTR	Hex Schmitt Inverter	SO14, TSSOP14
M74HC151YRM13TR / M74HC151YTTR	8-channel Multiplexer	SO16, TSSOP16
M74HC259YRM13TR / M74HC259YTTR	8-bit Addressable Latch	SO16, TSSOP16
M74HC280YRM13TR	9-bit Parity Generator	SO14
M74HC4060YRM13TR / M74HC4060YTTR	14-stage Binary Counter/Oscillator	SO16, TSSOP16
M74HC4094YRM13TR / M74HC4094YTTR	8-bit SIPO Shift Register Latch (3-State)	SO16, TSSOP16
M74HC595YRM13TR / M74HC595YTTR	8-bit Shift Register Output Latch (3-State)	SO16, TSSOP16
M74HC365YRM13TR / M74HC365YTTR	Hex Bus Buffer (3-State)	SO16, TSSOP16

USB-C and PD controllers

STUSB1700Y AND STUSB4700Y: USB-C AND PD CONTROLLERS FOR AUTOMOTIVE APPLICATIONS

Designed to address 15W charging (STUSB1700Y) or 60W charging (STUSB4700Y) in automotive applications, STUSB1700Y and STUSB4700Y are respectively USB-C and Power delivery standalone controller ICs. Paired with an appropriate power management IC, they are effective solutions for quick design of single or dual port satellites offering a maximum charging speed for Smartphone, Tablets, Notebook, portable gaming accessories or portable displays, drones etc...

Being hardwired controllers packaged in QFN with wettable flanks, STUSB1700Y and STUSB4700Y are robust, safe and interoperable controllers which received AEC-Q100 qualification at +105°C.



MAIN FEATURES

- Automotive Grade
- Internal VBUS Discharge
- Shorts-to-VBUS protection
- Vdd = [4.1V; 22V]
- Operating temperature range: -40 to +105 °C
- Package: QFN-24 wettable flanks



MAIN APPLICATIONS



USB car chargers



Front seats and Rear seats charging



12 V car chargers accessories



Infotainment systems



E-bikes

USB-C

Part number	Description	Role	Typical Power	Operating temperature (°C)		Package
				Min	Max	
USB-C and PD controller						
STUSB1700Y	USB-C controller	Source	Up to 5 V; 3 A	-40	+105	QFN24 (4x4 WF)
STUSB4700Y	USB PD controller	Source	Up to 20 V; 3 A	-40	+105	QFN24 (4x4 WF)

USB-C - 15 W PORT

USB Type-C receptacle

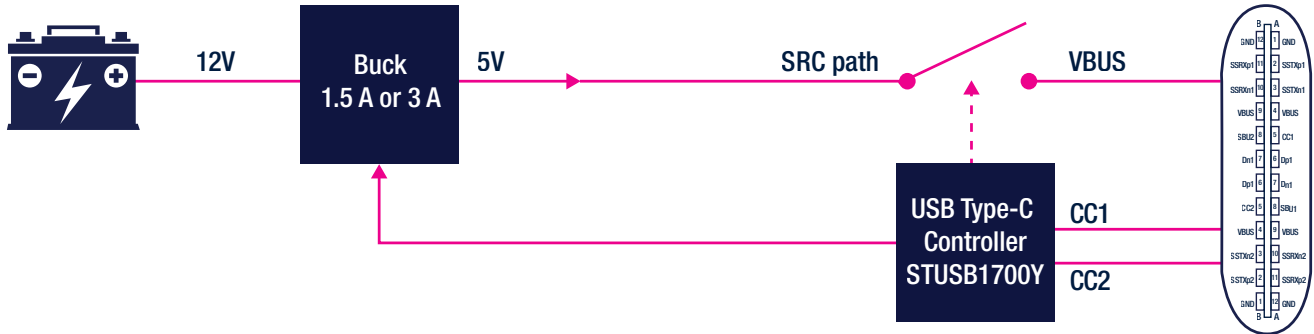

USB PD - 60 W PORT

USB Type-C receptacle

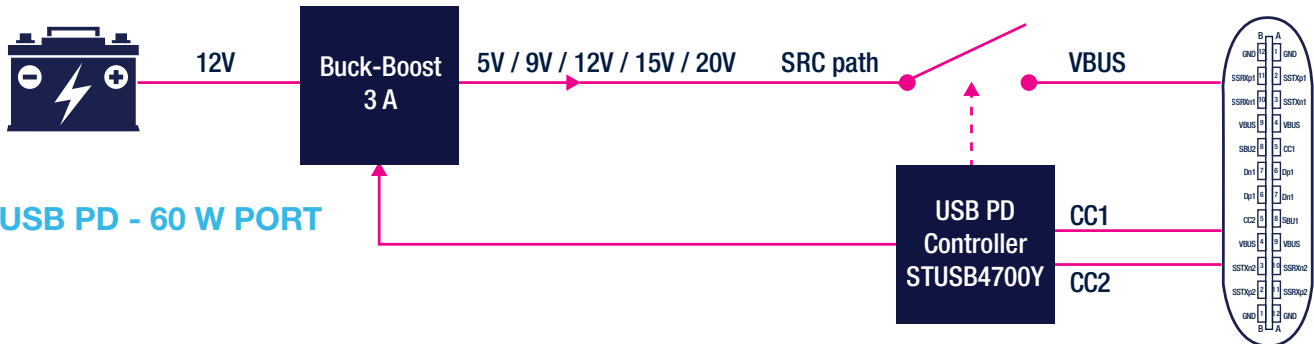

Voltage references

SHUNT VOLTAGE REFERENCES

TL1431: adjustable precision voltage reference

The TL1431 is a programmable shunt voltage reference with guaranteed stability over the entire operating temperature range. The output voltage may be set to any value between 2.5 and 36 V with two external resistors. The TL1431 operates throughout a wide current range from 1 to 100 mA with a typical dynamic impedance of 0.2 Ω .



FEATURES

- Adjustable output voltage: V_{REF} to 36 V
- Sink current capability: 1 to 100 mA
- Typical output impedance: 0.22 Ω
- 0.4 % and 0.25 % voltage precision
- Operating temperature range: -40 to +125 $^{\circ}\text{C}$
- Package: S08

Reference voltage vs. temperature

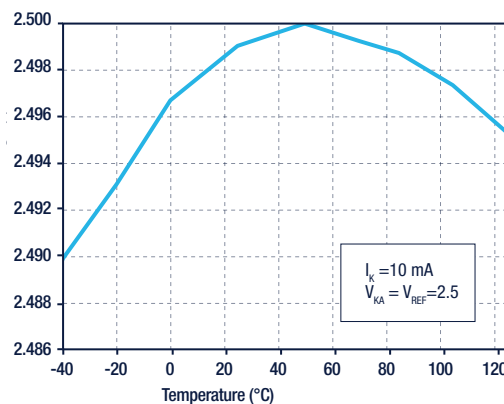

Pulse response for $I_k = 1 \text{ mA}$

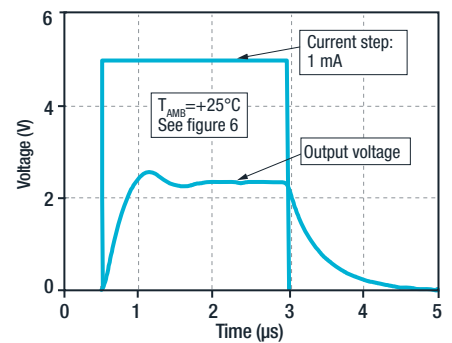

Shunt voltage references

Part number	Adjustable	V_{REF} (V)	Reference Input voltage (V)	Initial accuracy (\pm)	Temperature coefficient max ppm / $^{\circ}\text{C}$	Sink current range	Operating temperature range	Package
TL431AIYDT	Yes	2.5 to 36	2.5	1 %	± 30	1 mA to 100 mA	-40 to +125 $^{\circ}\text{C}$	S08
TL431IYDT				2 %				
TL1431AIYDT				0.25 %				
TL1431IYDT				0.4 %				
TS431IYLT		1.24 to 6	1.24	2 %	± 21	60 μA to 30 mA	-40 to +125 $^{\circ}\text{C}$	SOT23-5L
TS431AIYLT				1 %				
TS431BIYLT	0.5 %							

Watchdog, reset and supervisor ICs

STWD100: watchdog timer circuit for automotive applications

The STWD100 watchdog timer circuits are self-contained devices which prevent system failures caused by certain types of hardware errors (including non-responding peripherals and bus contention) or software errors (such as a bad code jump or code stuck in loop). A watchdog input (WDI) signal periodically resets the internal watchdog timer within a specified timeout period. If the system fails, the watchdog timer is not reset, a system alert is generated and the watchdog output is asserted. The small SOT23-5 package ensures a small board impact area and has a low current consumption of only a few μA .



FEATURES

- Current consumption 13 μA (typ.)
- Supply voltage: 2.7 to 5.5 V
- Available watchdog timeout periods are 3.4 ms, 6.3 ms, 102 ms, and 1.6 s
- Chip enable input
- Open-drain or push-pull WDO output
- Operating temperature range: -40 to +125 °C
- Package: SOT23-5
- ESD performance: 2 kV (HBM) and 1 kV (CDM)

MAIN APPLICATIONS



Advanced driver assistance systems (ADAS)



Infotainment



Telematics and connectivity

Part number	Watchdog	Supervisor	Manual reset input	V_{DD} (V)	I_{CC} (μA)	Watchdog Timeout Period	Output type	Reset Pulse width	Package
STWD100YNPWY3F	Yes	No	No	2.7 to 5.5	13	3.4 m	Open-drain	NA	SOT23-5
STWD100YNWWY3F						6.3 ms			
STWD100YNXWY3F						102 ms			
STWD100YNYWY3F						1.6 s			

Current sensing in BLDC motor applications

APPLICATION NOTE AN5423 SUMMARY

Introduction

The brushless DC motor is becoming more and more popular in domains such as industrial automation, automotive, medical and health care appliance thanks to their high reliability and durability.

Different techniques can be used to sense the current, but one of the most effective uses the in-line phase current. This method requires the use of dedicated current sensing ICs able to work with common mode largely higher than the power supply, and with an especially good and fast response time to fast common mode step variations.



Inline phase current

The configuration shown in Figure 1 is the best method to know precisely the current flowing into the motor. And this current measurement offers the best information that can be used in feedback motor control, in order to optimize the motor performance.

As the shunt resistor is placed directly in line with the PWM driver, it requires the use of dedicated current sensing able to reject fast common mode variations.

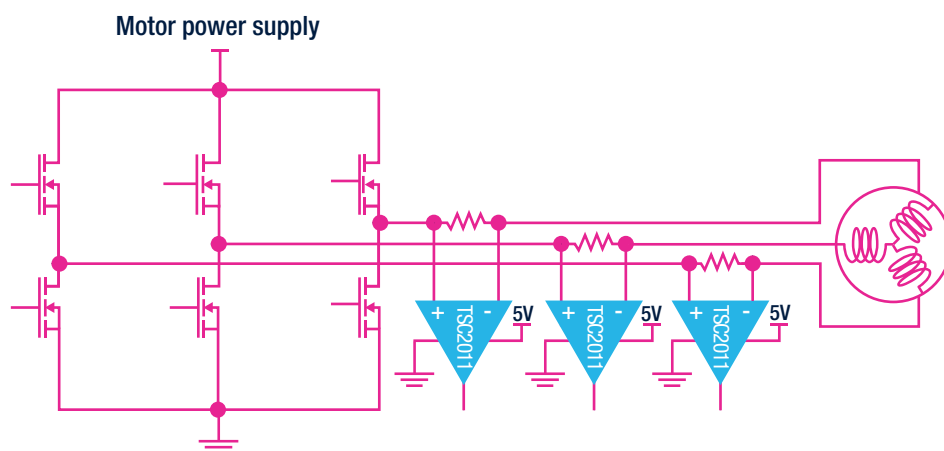

Figure 1: Inline phase current sensing

The TSC2011 is a bidirectional high side current sensing amplifier designed for use in such a configuration.

The main advantage of this topology is that the current can be read without a strong linkage to the PWM status and without timing limitations in the event a very small PWM signal is applied to the phase (low side current sensing can only be executed while the low side transistor of that leg is on).

It also can detect phase short-circuits.

Theoretical maximum error calculation

The principal sources of error that can be seen on the TSC2011 output are mainly due to input offset voltage, gain error and common mode rejection ratio. In addition, the accuracy of the shunt resistor should be taken into account. The maximum total error expected on the output of the device can be described as the sum of these different sources as described by equation (1).

$$V_{out} = G \left(1 + \epsilon_G + \left| \frac{dG}{dT} \right| \cdot \Delta T \right) \cdot (R_{shunt} (1 + \epsilon_{shunt}) \cdot I_{sense}) + (V_{io} + \left| \frac{dV_{io}}{dT} \right| \cdot \Delta T) + \left(\frac{|V_{icm} - 12V|}{CMRR} \right) + \left(\frac{V_{ref1} + V_{ref2}}{2} \right) (1 + \epsilon_{ref}) + Noise$$

It is important to note that this has been calculated using all the maximum values and all errors have been added to each other, meaning that the chance to get this worst case condition is extremely low, and the error in the most parts of the application will be largely smaller.

The noise can be then expressed as two times the first one related to the 1/f noise and the second due to the white noise. As the noise is bandwidth-dependent, the higher the application's bandwidth, the greater the noise.

So the RMS value of the output noise given in VRMS is the integration of the spectral noise over a dedicated bandwidth BW can be expressed by equation (2):

$$n_{RMS} = \left(\int_{0.1}^{10000} \left(\frac{100 \cdot 10^{-9}}{\sqrt{f}} \right)^2 df + \int_{0.1}^{154000} \frac{\pi}{2} (29 \cdot 10^{-9})^2 df \right) \cdot Gain$$

Figure 2 represents the total error in % on the output at ambient and 125°C, for $V_{icm}=12V$, by using a shunt of 20mΩ at 1% and a current flowing into one motor phase in the range of [0.2 to 2A].

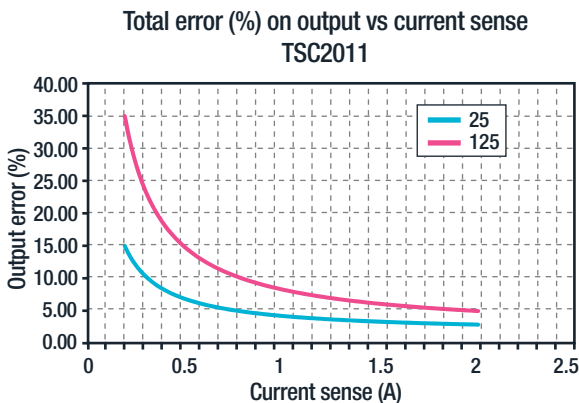

Figure 2: Total error vs current @ $V_{icm}=12V$

TSC2011 in motor application

Figure 3 shows the response of the TSC2011 in the application described by Figure 1.

Only one phase current motor out of three has been measured.

The PWM frequency of the motor is 20 kHz, represented by the blue curve in Figure 3.

The current flowing in one phase of the motor is in the range of 2.5A, for a 7000 rpm motor speed.

The pink curve is issued from a current probe placed on the same phase than the shunt resistance. The green curve represents the output of the TSC2011, after a RC filter (154 kHz), and shows the good signal integrity of the TSC2011.

On the fast transition of the current, a response time of less than 5μs can be observed, due to the TSC2011 response time to a fast-common mode transition and the RC filter constant time.

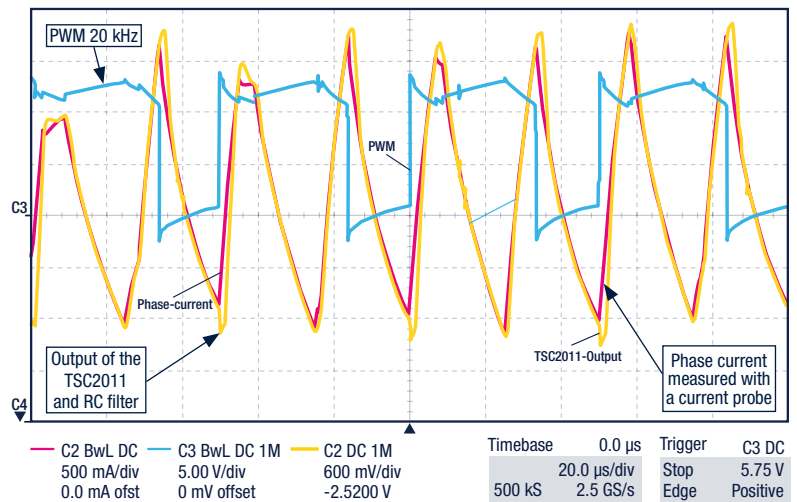

Figure 3: behavior of the output of the TSC2011 in a motor application.

Conclusion

In motor control applications, the ability to measure current is essential in order to provide feedback about the motor. When an accurate measurement of the phase current is critical, for example in electric power steering or e-turbo applications or when functional safety is a must, inline current sensing is very good solution.

Thanks to their good response time to a fast step variation on input common mode voltages, ST's TSC20xx series of precision bidirectional current sense amplifiers is a good choice for these kinds of applications. Our high-voltage bidirectional current sense amplifier evaluation kit based on the TSC2010, TSC2011 and TSC2012 (STEVAL-AETKT1V2) is a good way to get started.



Inside the STEVAL-AETKT1V2 evaluation kit, there are one main board and three daughter boards for the TSC2010, TSC2011 and TSC2012.

Current sensing for 48 V batteries

APPLICATION NOTE AN4909 SUMMARY

Introduction

Standard automotive protections are designed to immediately cut off current to the load when overcurrent, short-circuit, or overtemperature events are detected. Due to the growing demand for increased energy efficiency and less pollutant emissions, certain automotive platforms are adding a second 48 V battery which requires an electronic adaptation to the higher supply voltage range.

This application note describes a simple way to protect against ground loss or offset, voltage peaks, reverse or disconnected battery, and load dumps for 48 V battery applications.

Designed with AEC-Q100 compliant components already in mass-production, this intelligent power switch precisely measures the current load and quickly disconnects the power when a system fault occurs.

This application note covers basic system considerations including precision, speed and design architecture.



General Overview

This function is realized using a TSC1031YDT/PT high-side current-sense amplifier (Figure 1) which ensures a precise current measurement.

Figure 1: General system overview

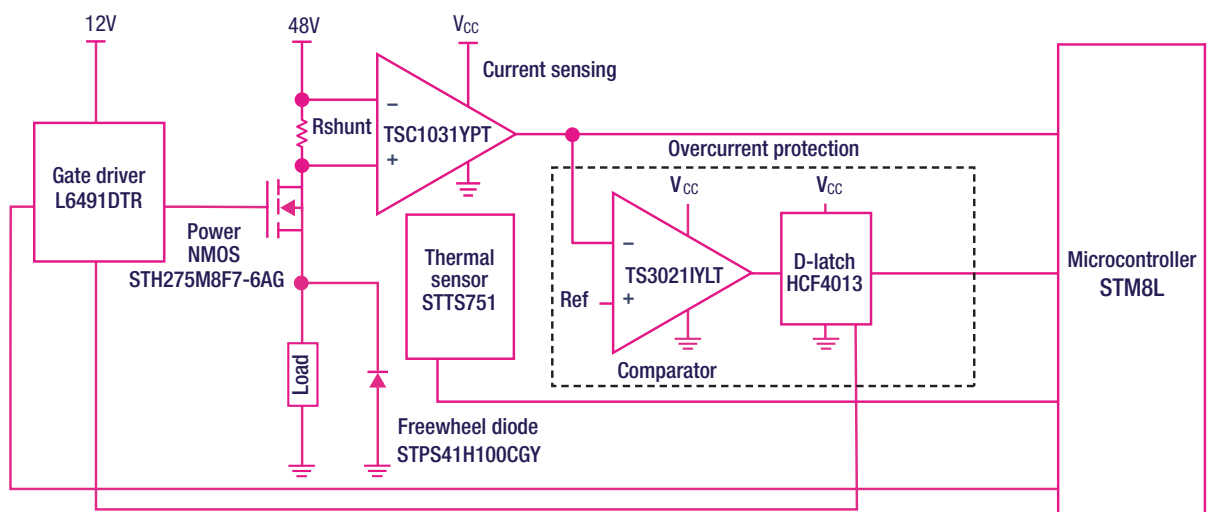
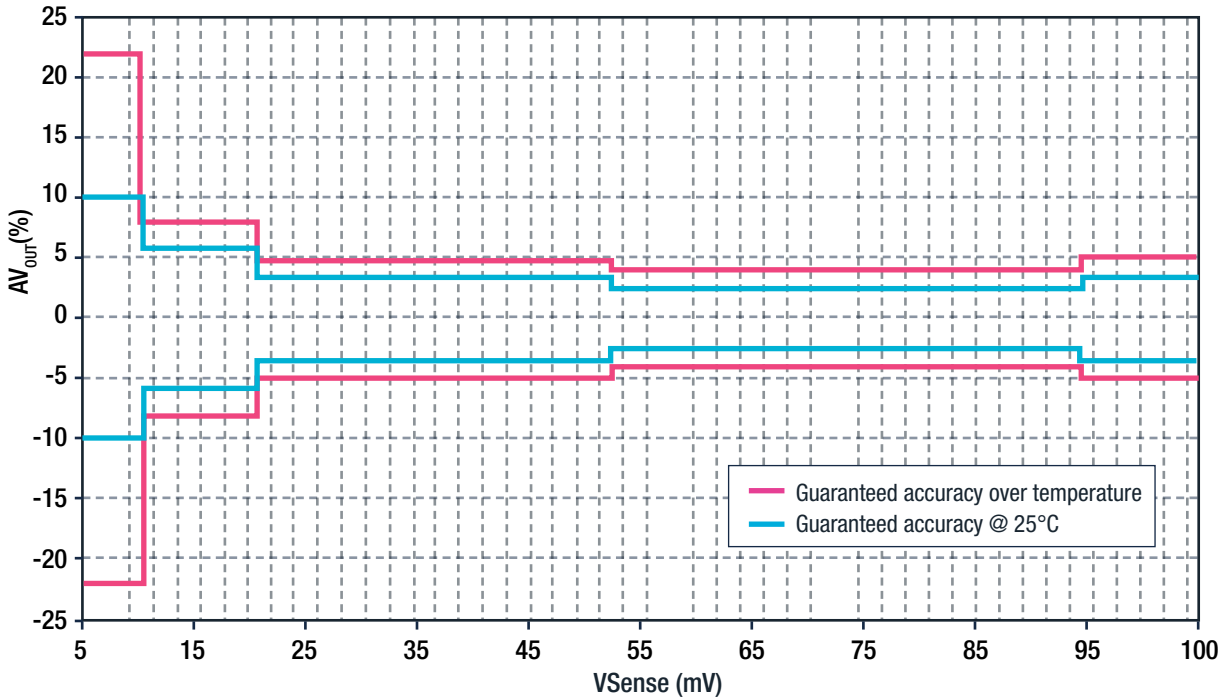

Figure 2 describes the maximum guaranteed error, which can happen on the output of the TSC1031 at 25°C and for over-temperature conditions

The current measurement is extremely important, firstly to control the current flowing into the load and also to be able to take a decision in case of a default like a short circuit or

over current event. This function is realized thanks to the high side current sensing TSC1031IYDT/PT which allow a precise measurement. The figure describes the maximum guaranteed error, which can happen on the output of the TSC1031 at 25°C and over temperature

Figure 2: Maximum output voltage error of the TSC1031



The N-channel Power MOSFET is a key component as it helps control the load current and also protect the application when a fault is detected. In addition being able to sustain the high 48V voltage range as well as load dumps, its RDS(ON) must be as low as possible in order to limit power dissipation. The STH275N8F7-6AG is an 80V STripFET F7 Power MOSFET with a maximum RDS(ON) of 2.1 mΩ at 25 °C.

When a short-circuit or over-current event is detected, the application must be switched off as quickly as possible. Moreover after such an event, the application must not restart by itself and must remain switched off until a manual reset is applied.

When using a TS3021Y high-speed comparator with an HCF4013 dual-D flip-flop to realize a latch function, it takes less than 9 μs to switch off the Power NMOS when an over-current event is detected in the load.

In the particular case of this application, an STTS751 thermal sensor is used to control the MOS temperature in order to protect the PCB when it exceeds 125 °C.

Moreover, an STM8L microcontroller is used to generate a configurable PWM in order to drive the gate of the power NMOS by analyzing the data coming from the current sensor. In case of overheating, it is also able to stop the system by opening the NMOS and can generate an alarm when an over-current event occurs.

eDesignSuite

THE SMART DESIGN TOOL

ST's eDesignSuite is a smart design and simulation tool that greatly simplifies the task of engineers working on various application types. This platform helps to select the best product for your application and speeds -up the design-in! To use the eDesignSuite, you must first register on MyST at

<https://eds.st.com/console/#/home>

Available modules

- Power management
- Thermo-electrical simulator
- Signal conditioning
- NFC/RFID calculators

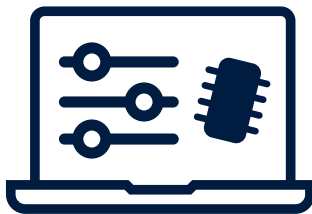

STEP 1

- Select the module

STEP 2

- Select the type of product family

STEP 3

- Adjust your choice with different parameters (stability, efficiency, center frequency, bandwidth...)

...you can then

- Get the suggested schematics
- Get the Bill Of Material (BOM)
- Get the different charts depending on the selected product (waveforms, efficiency, gain, phase...) in order to analyze your filter easily

- Access the Datasheet
- Access the Product folder
- Save and export a PSPICE model
- Export for eDSim



Mobile apps

ST VOLTAGE REGULATORS APP

The ST Vreg app (ST-VREG-FINDER) is a free all-in-one smart selector for smartphones and tablets. You can select the products that fit your application needs from among our Linear and switching voltage regulators and Voltage reference portfolios.

The app includes a parametric search engine and a browser by product family, for easy sorting and filtering. Once you have made your selection, share the relevant documentation by mail or social media, check the availability of samples and order them in few clicks!



Download from the App Store or Google Play



The ST Vreg Finder is available on Google Play and App Store
www.st.com/vreg-finder

ST OP AMPS APP

The ST Op Amps app (ST-OPAMPS-APP) is a free all-in-one design toolkit and smart selector for smartphones and tablets. You can select the best product from among our operational amplifier, comparator, current-sensing, power and high-speed amplifier portfolios for your application.

Sort, compare and filter electrical parameters or use the smart component value calculator with interactive schematics. Search using the competitor cross-reference tool and access 3D.



Download from the App Store, Google Play or Wandoujia

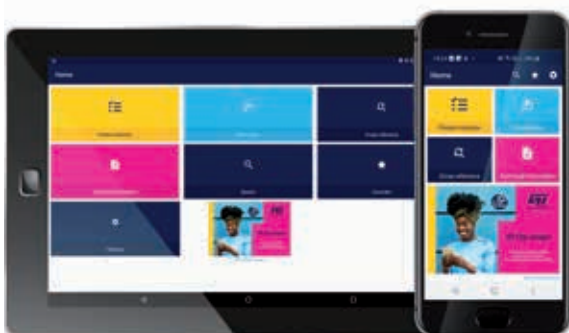

The ST Op Amps App is available on Google Play and App Store
www.st.com/opamps-app

life.augmented



Order code: BR2206AUTOICS

For more information on ST products and solutions, visit www.st.com

© STMicroelectronics - June 2022 - Printed in United Kingdom - All rights reserved
ST and ST logo are trademarks or registered trademarks of STMicroelectronics International NV or its affiliates in the EU and/or other countries. For additional information about ST trademarks, please refer to www.st.com/trademarks.
All other product or service names are the property of their respective owners.



life.augmented