

Modular approach to power electronics

Introducing the low voltage drives scalable power demonstration board

Abstract

A modular approach to building up fully scalable test bench power setups of various power topologies is proposed in this white paper. Being able to quickly test new power devices can be reflected in time to market of newly developed or revised existing power systems like three-phase motor drive inverters. The modules provided by Infineon together with supporting software enable the designers to significantly shorten the process of setting up working prototypes in the initial design stage. The setup can then serve as the reference for system optimization and further improvement by adjusting component values and testing new power MOSFET technologies.

By Urban Medič, Application Engineer, Infineon Technologies AG

Table of contents

1 Introduction	3
2 Versatility of the modular design	4
2.1 Power board versions	4
2.2 Mother board and single half-bridge setup	5
2.3 Paralleling of power MOSFETs in a single half-bridge setup	5
2.4 Multi-phase system – three-phase motor inverter (B6)	6
3 Control card	8
3.1 Software tool	8
4 Conclusion	10

1 Introduction

Designing high power drive systems at low voltages (< 144 V) requires high current handling, and managing considerable thermal dissipation which is typically achieved by paralleling of semiconductor devices – primarily MOSFETs due to their low conduction and switching losses.

The extent of MOSFET paralleling is the main focus of performance versus cost optimization of the system where equal current sharing and switching performance optimization play essential roles in the hardware design.

While insulated metal substrate (IMS) PCB technology is the prevailing technology of choice due to its outstanding thermal performance, it is not the best suited solution for board rework processes that are necessary in the initial design phase quite often.

Infineon is offering a modular platform for developing half-bridge based power systems of various power handling capabilities at different voltage levels. Moving the gate drive circuitry to a separate FR-4 board makes any necessary rework on the boards easier and faster. Using a modular half-bridge approach enables easy adaptation of MOSFET paralleling. The platform enables rapid prototyping in the initial project design process, and offers the possibility of technology comparison and system adaptation when moving to new MOSFET technologies.



Figure 1 Typical low voltage, high power application: forklift

2 Versatility of the modular design

Scalability and versatility is the focus of the low voltage drives scalable power demonstration board platform. The concept supports half-bridge, full-bridge or three-phase applications. It enables the user to vary the number of paralleled half-bridge MOSFET modules which build up each of the phases in a motor drive inverter.

The platform consists of several different boards (modules) that can be used to design a functional power assembly. By role (or functionality) in the setup, the modules can be arranged into five categories:

- › **Power board:** MOSFET half-bridge configuration
- › **Mother board and master mother board:** gate driver board – connects to the first paralleled power board
- › **Daughter board:** interconnection between the gate driver and the paralleled power boards
- › **Capacitor board:** PCB accommodating up to twelve capacitors connected to the DC bus
- › **Control board:** drive card XMC4400 demonstration board

2.1 Power board versions

These IMS based half-bridge (sub)assemblies represent the heart of the low voltage drives scalable power demonstration board. Comprising a single high-side and a single low-side MOSFET with all the necessary connectors and test points, the power board is the basic building block of the modular platform.

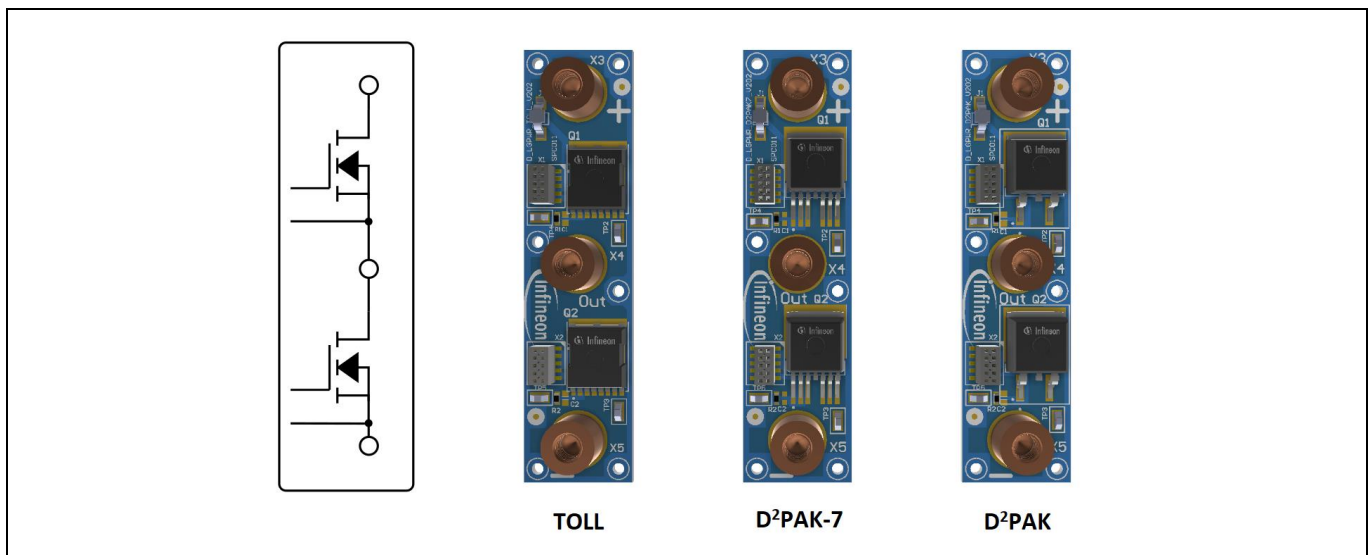

Figure 2 Power boards – Implementation of different MOSFET packages

Figure 2 shows the different versions of the power boards available. Each board implements a different MOSFET package while maintaining the same interconnection layout, so that all the different power board versions are interchangeable.

The package types featured in the power board designs are:

- › TO-Leadless (TOLL)
- › D²PAK-7
- › D²PAK

The modular platform was designed for test purposes. A number of test point connectors are provided on the boards.

The jumper provided at the high-side drain (the DC+ node) enables the user to utilize a Rogowski current probe for MOSFET drain current measurements.

You can find all available versions with regard to MOSFET products provided [online](#).

2.2 Mother board and single half-bridge setup

Connecting the Master mother board to a power board through provided headers, subsequently connects the gate driver IC to the high- and low-side MOSFETs. The gate resistors (RG1 and RG2), and other components required for optimization of gate drive signal, are situated on the FR-4 based master mother board. This is to enable easy extraction and replacement of the resistors when experimenting with the component values.

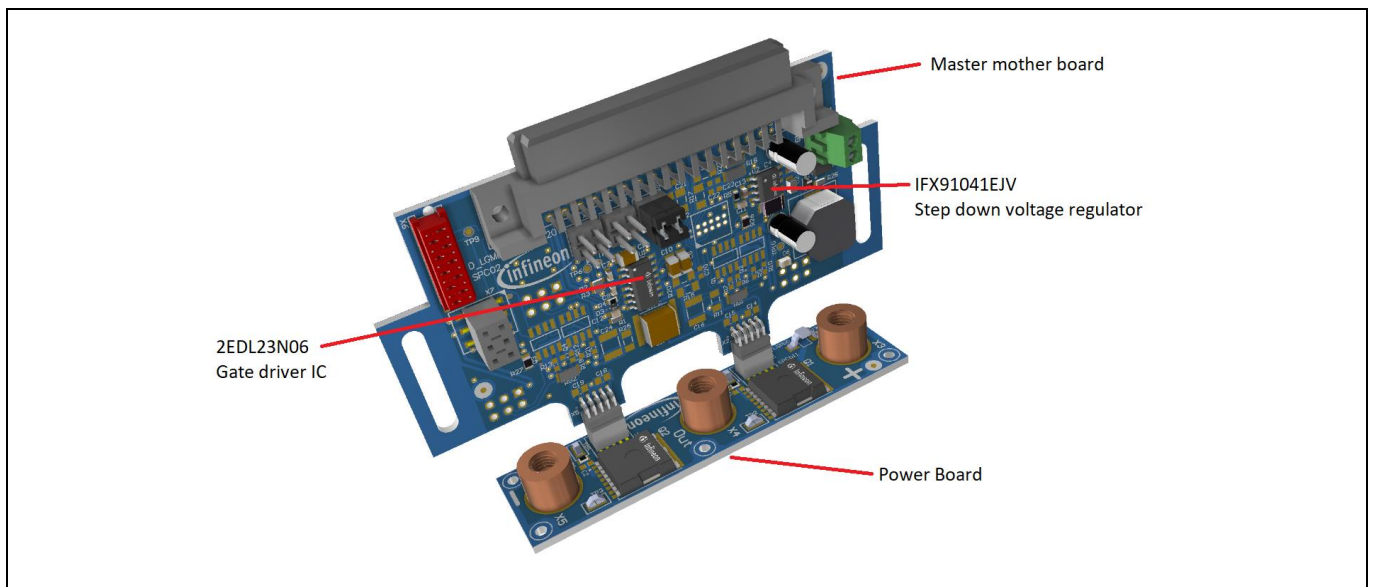

Figure 3 Master mother board with single power board

The minimal assembly (shown in Figure 3) can serve as a basic platform to observe and tweak the switching behavior of an individual half-bridge with no MOSFET paralleling.

2.3 Paralleling of power MOSFETs in a single half-bridge setup

When expanding an individual phase with additional half-bridge modules connected in parallel, the same gate driver IC is used to drive the paralleled power boards. For this reason, each of the additional power boards is connected to the gate driver board through a daughter board, which also provides the gate resistors for each of the power MOSFETs. The daughter boards are stacked via available header connectors that form a parallel bus of the gate driver signals.

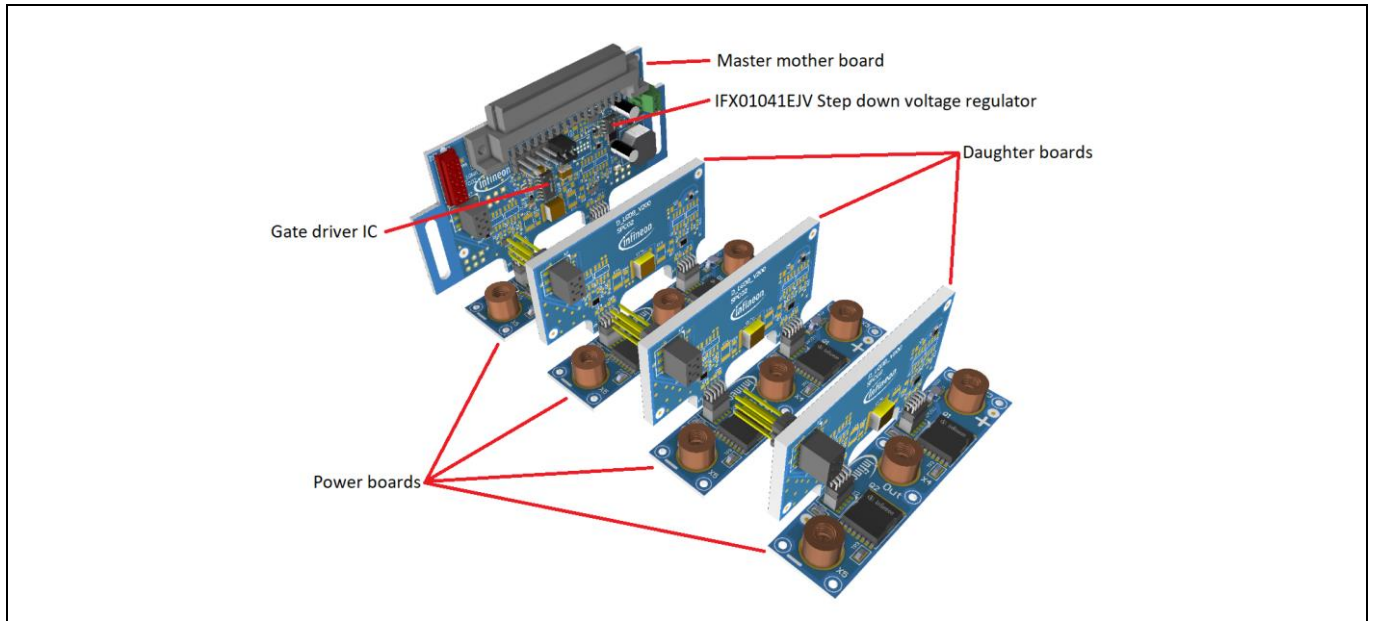

Figure 4 Adding power boards in parallel

The surface mount device (SMD) power connectors are provided on power boards for the high current interconnection via copper bars - for each phase two copper bars form the DC bus connection that connects all the parallel half-bridges of that phase to the capacitor bank, and to the DC power source. Another copper bar connects the outputs of the paralleled half-bridges and provides the connection point for the motor.

2.4 Multi-phase system – three-phase motor inverter (B6)

A three-phase motor drive inverter is composed of three-phase assemblies, such as described in [chapter 2.3](#). In a three-phase system the phase “U” uses the Master mother board, and the phases “V” and “W” utilize the mother boards without the supply sub circuit.

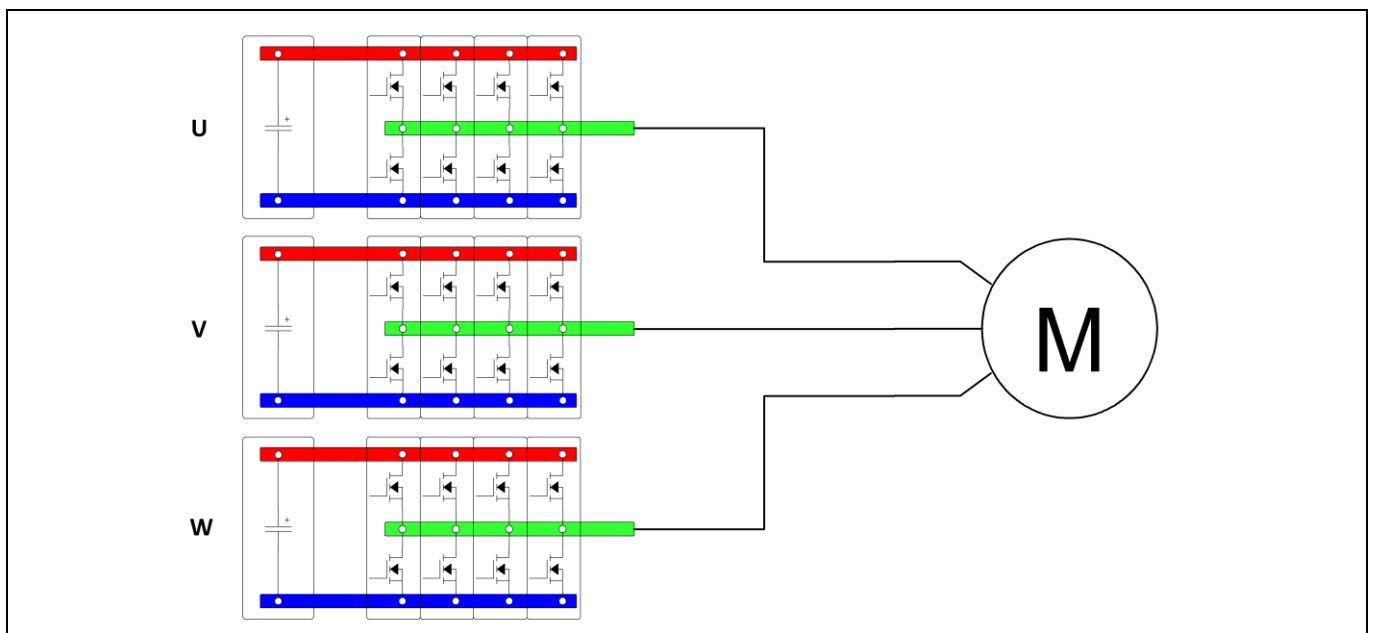

Figure 5 B6 motor drive topology

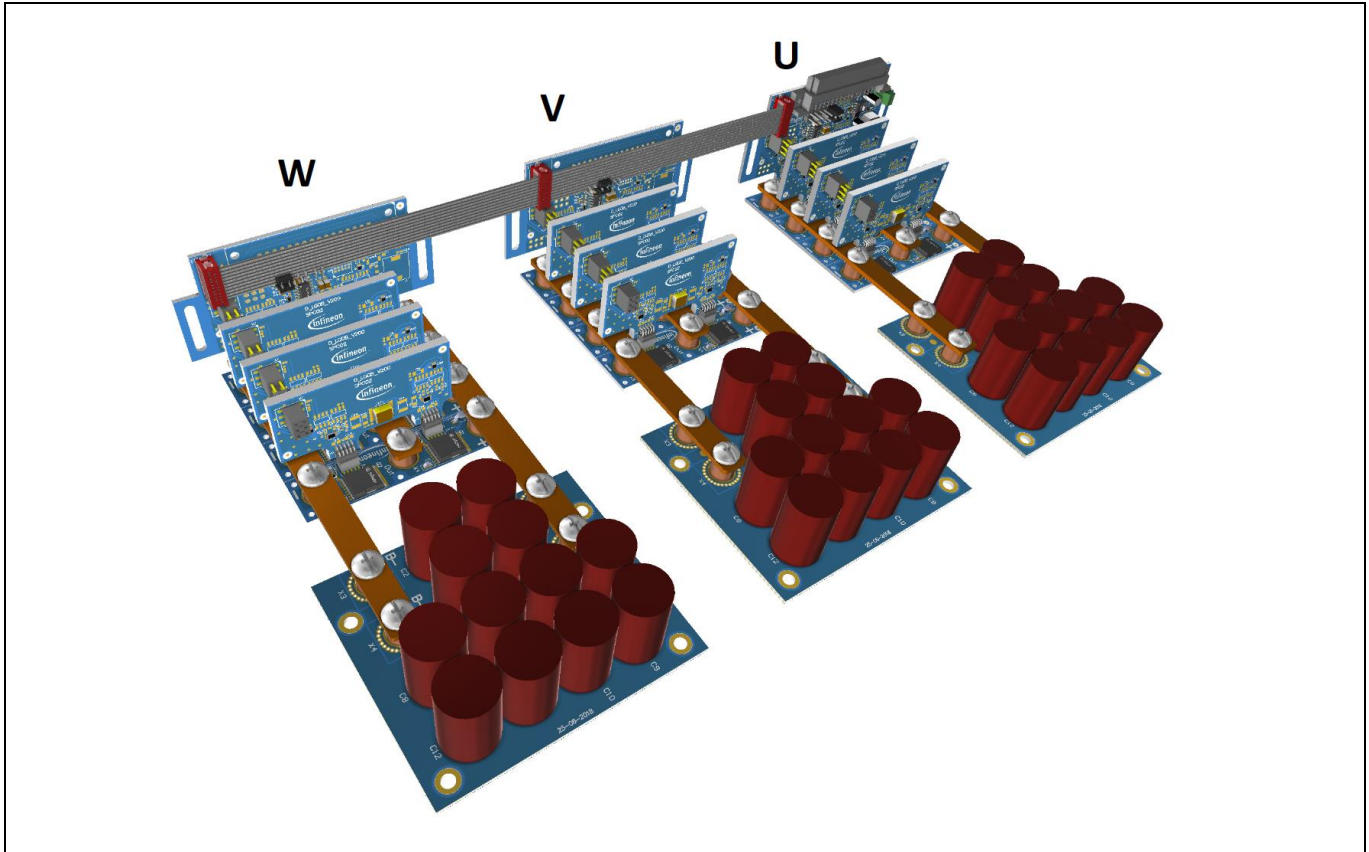

Figure 6 B6 motor drive implemented with the scalable power demonstration board

The setup shown in Figure 6 has all necessary power parts to drive a multiple kilowatt three-phase motor. The setup consists of three half-bridges with four MOSFETs in parallel per each switch. Depending on thermal management and electrical environment the output power of more than 10 kW is achievable.

Modules required to assemble this setup are listed in Table 1.

Table 1 Board count for B6 topology with four parallel MOSFETs per switch

Module category	Quantity	Function
Power board	12	Power half-bridge – MOSFET carrier
Master mother board	1	Includes 2EDL23N06 half-bridge gate driver – connects to the first power board and also provides supply for XMC™ control card
Mother board	2	Includes 2EDL23N06 gate drivers for second and third phase
Daughter board	9	Interconnection between the gate driver and the power boards
Capacitor board	3	PCB interconnecting twelve capacitors for the DC bus

3 Control card

The three-phase power stage can be driven with a single XMC™ microcontroller card. The connector provided in the Master motherboard is adapted for interfacing with [Infineon's XMC™ demonstration board drive card XMC4400](#) (see Figure 7).

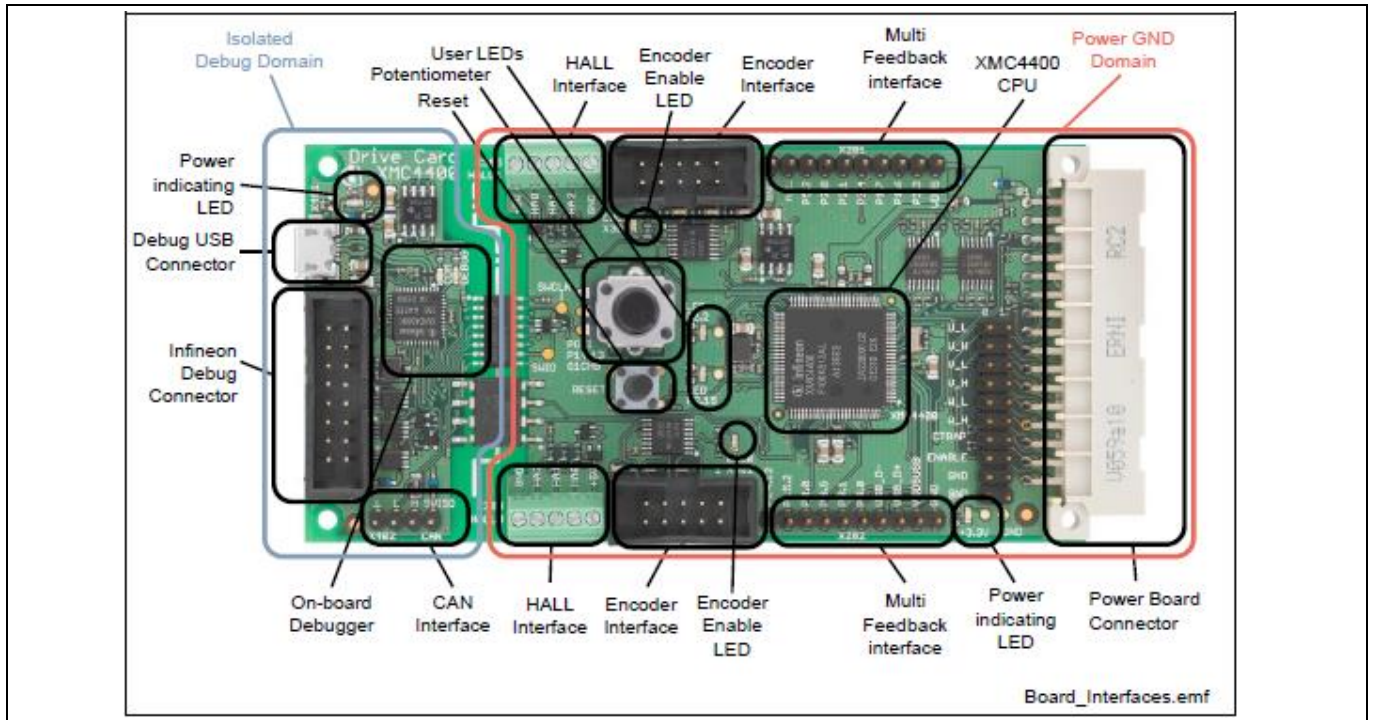

Figure 7 XMC4400 drive card demonstration board

3.1 Software tool

A simple GUI for a quick startup of the induction motor is provided in the software package. For simplicity purposes the software is based on open loop V/f control with the option of enabling the overcurrent protection.

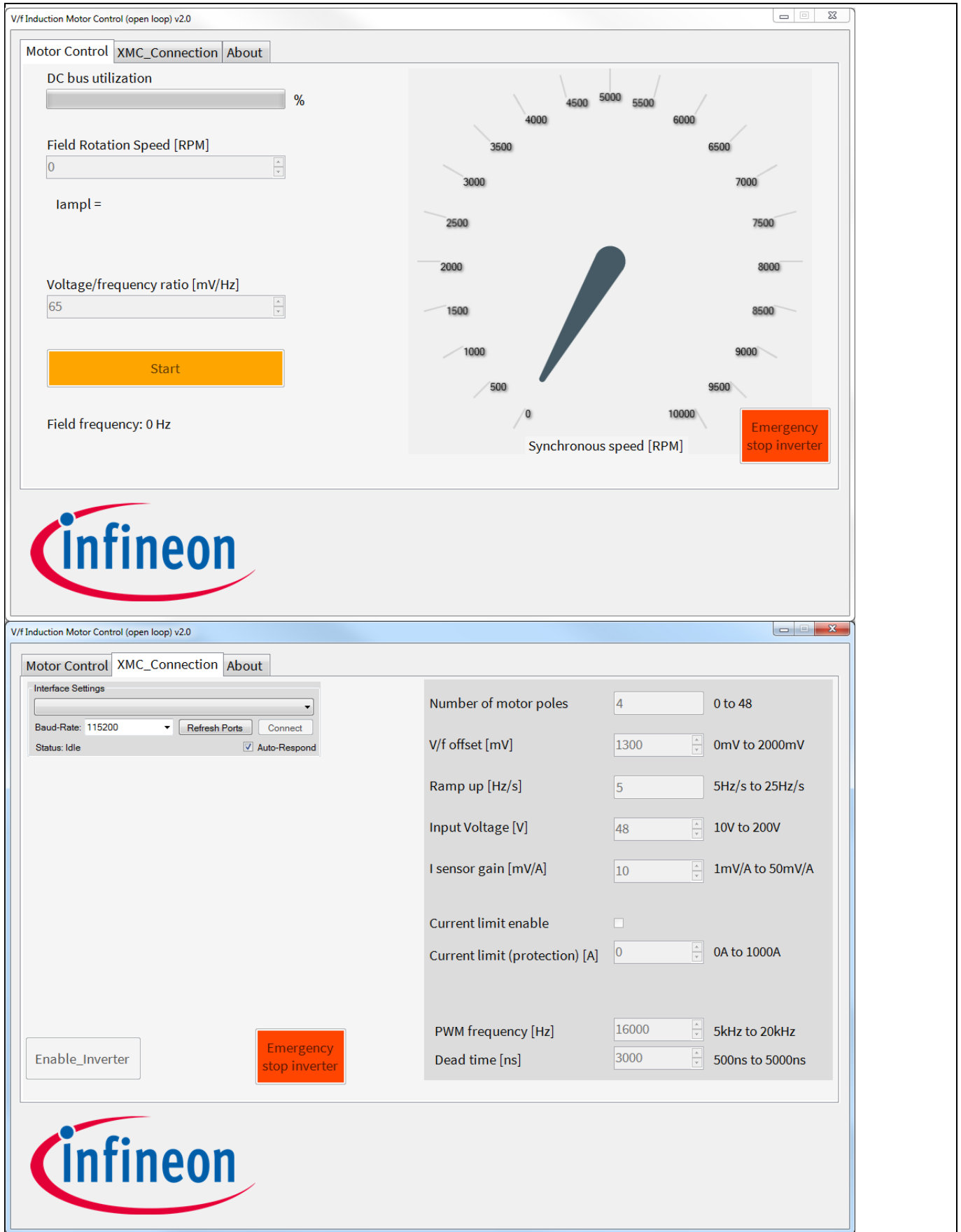

Figure 8 Software GUI

4 Conclusion

Infineon's low voltage drives scalable power demonstration board serves as a platform that provides the building blocks for rapid prototyping in power electronics. It offers designers an easy-to-use hardware to compare and test the suitability of new technologies without spending the time on expensive preliminary and proof-of-concept designs. The platform can be used in numerous solutions covering several topologies in various voltage levels and current handling capabilities.

Published by
Infineon Technologies AG
85579 Neubiberg, Germany

© 2019 Infineon Technologies AG.
All Rights Reserved.

Order Number: B131-I0772-V1-7600-EU-EC
Date: 3 / 2019

Please note!

THIS DOCUMENT IS FOR INFORMATION PURPOSES ONLY AND ANY INFORMATION GIVEN HEREIN SHALL IN NO EVENT BE REGARDED AS A WARRANTY, GUARANTEE OR DESCRIPTION OF ANY FUNCTIONALITY, CONDITIONS AND/OR QUALITY OF OUR PRODUCTS OR ANY SUITABILITY FOR A PARTICULAR PURPOSE. WITH REGARD TO THE TECHNICAL SPECIFICATIONS OF OUR PRODUCTS, WE KINDLY ASK YOU TO REFER TO THE RELEVANT PRODUCT DATA SHEETS PROVIDED BY US. OUR CUSTOMERS AND THEIR TECHNICAL DEPARTMENTS ARE REQUIRED TO EVALUATE THE SUITABILITY OF OUR PRODUCTS FOR THE INTENDED APPLICATION.

WE RESERVE THE RIGHT TO CHANGE THIS DOCUMENT AND/OR THE INFORMATION GIVEN HEREIN AT ANY TIME.

Additional information

For further information on technologies, our products, the application of our products, delivery terms and conditions and/or prices please contact your nearest Infineon Technologies office (www.infineon.com).

Warnings

Due to technical requirements, our products may contain dangerous substances. For information on the types in question please contact your nearest Infineon Technologies office.

Except as otherwise explicitly approved by us in a written document signed by authorized representatives of Infineon Technologies, our products may not be used in any life endangering applications, including but not limited to medical, nuclear, military, life critical or any other applications where a failure of the product or any consequences of the use thereof can result in personal injury.