

PSoC™ 4 and PSoC™ 6 MCU CAPSENSE™ design guide

About this document

Scope and purpose

The CAPSENSE™ design guide explains how to design capacitive touch sensing applications with the CAPSENSE™ feature in PSoC™ 4 and PSoC™ 6 MCU device families. The CAPSENSE™ feature offers unprecedented signal-to-noise ratio (SNR), best-in-class liquid tolerance, and a wide variety of sensors such as buttons, sliders, touchpads, and proximity sensors. This design guide explains the CAPSENSE™ operation, CAPSENSE™ design tools, performance tuning of the PSoC™ Creator and ModusToolbox™ CAPSENSE™ component and design considerations. This guide also introduces Fifth Generation CAPSENSE™ technology which has several advantages over the previous generation devices.

Different device families are available with CAPSENSE™ feature. If you have not chosen a particular device, or are new to capacitive sensing, see the [Getting started with CAPSENSE™ design guide](#). It helps you understand the advantages of CAPSENSE™ over mechanical buttons, CAPSENSE™ technology fundamentals, and to select the right device for your application. It also directs you to the right documentation, kits, or tools to help with your design.

Intended audience

This document is primarily intended for engineers who need to become familiar with the CAPSENSE™ design principles of PSoC™ 4 and PSoC™ 6 MCU devices.

Table of contents

	About this document	1
	Table of contents	1
1	Introduction	8
1.1	Overview	8
1.2	CAPSENSE™ features	8
1.3	PSoC™ 4 and PSoC™ 6 MCU CAPSENSE™ Plus features	9
1.4	CAPSENSE™ design flow	10
2	CAPSENSE™ technology	13
2.1	CAPSENSE™ fundamentals	13
2.1.1	Self-capacitance sensing	14
2.1.2	Mutual-capacitance sensing	16
2.2	Capacitive touch sensing method	17
2.2.1	CAPSENSE™ sigma delta (CSD)	18
2.2.2	CAPSENSE™ crosspoint (CSX)	18
2.3	Signal-to-noise ratio (SNR)	20
2.4	CAPSENSE™ widgets	21
2.4.1	Buttons (zero-dimensional)	21
2.4.2	Sliders (one-dimensional)	25
2.4.3	Touchpads/Trackpads (two-dimensional)	26
2.4.4	Proximity (three-dimensional)	27
2.5	Liquid tolerance	28
2.5.1	Liquid tolerance for self capacitance sensing	29

Table of contents

- 2.5.1.1 Effect of liquid droplets and liquid stream on a self-capacitance sensor 29
- 2.5.1.2 Driven shield signal and shield electrode 33
- 2.5.1.3 Guard sensor 34
- 2.5.2 Liquid tolerance for mutual-capacitance sensing 35
 - 2.5.2.1 Effect of liquid droplets and liquid stream on a mutual-capacitance sensor 35
 - 2.5.2.2 Using self-capacitance sensing for liquid tolerance of mutual-capacitance sensors 36
- 2.5.3 Effect of liquid properties on liquid-tolerance performance 37
- 3 PSoC™ 4 and PSoC™ 6 MCU CAPSENSE™ 39**
 - 3.1 CAPSENSE™ generations in PSoC™ 4 and PSoC™ 6 39
 - 3.2 Capacitive Sigma-Delta (CSD) sensing method (third and fourth generation) 42
 - 3.2.1 GPIO cell capacitance to current converter 43
 - 3.2.2 IDAC sourcing mode 43
 - 3.2.3 IDAC sinking mode 45
 - 3.2.4 CAPSENSE™ clock generator 46
 - 3.2.4.1 Sense Clock 46
 - 3.2.4.2 Modulator clock 47
 - 3.2.5 Sigma-delta converter 47
 - 3.2.6 Analog multiplexer (AMUX) 49
 - 3.2.7 CAPSENSE™ CSD shielding 49
 - 3.3 CAPSENSE™ CSX sensing method (third- and fourth- generation) 49
 - 3.4 CAPSENSE™ CSD-RM sensing method (fifth-generation and fifth-generation low-power) 52
 - 3.4.1 GPIO cell capacitance to charge converter 54
 - 3.4.2 Capacitor DACs (CDACs) 57
 - 3.4.3 CAPSENSE™ clock generator 57
 - 3.4.3.1 Sense clock 57
 - 3.4.3.2 Modulator clock 58
 - 3.4.4 Ratiometric sensing technology 58
 - 3.4.5 Analog multiplexer (AMUX) and control matrix (CTRLMUX) 59
 - 3.4.6 CAPSENSE™ CSDRM shielding 59
 - 3.4.6.1 Active shielding 60
 - 3.4.6.2 Passive shielding 60
 - 3.5 CAPSENSE™ CSX-RM sensing method (fifth-generation and fifth-generation low-power) 61
 - 3.5.1 Ratiometric sensing technology 63
 - 3.6 Advantages of fifth generation and fifth generation low-power 64
 - 3.6.1 Autonomous scanning 64
 - 3.6.2 Usage of multiple channels 64
 - 3.6.3 CIC2 64
- 4 CAPSENSE™ design and development tools 67**
 - 4.1 PSoC™ Creator 67
 - 4.1.1 CAPSENSE™ component 67
 - 4.1.2 CapSense_ADC component 68

Table of contents

4.1.3	Tuner GUI	68
4.1.4	Example projects	68
4.2	ModusToolbox™	69
4.2.1	CAPSENSE™ middleware	69
4.2.2	CAPSENSE™ configurator	69
4.2.3	CSDADC middleware	70
4.2.4	CSDIDAC middleware	70
4.2.5	CAPSENSE™ Tuner	70
4.2.6	Example projects	71
4.3	Hardware kits	71
5	CAPSENSE™ performance tuning	73
5.1	Selecting between SmartSense and manual tuning	73
5.2	SmartSense	73
5.2.1	Overview	73
5.2.2	SmartSense full auto-tune	75
5.2.2.1	Tuning button widgets	75
5.2.2.2	Tuning slider widgets	78
5.2.2.3	Tuning proximity widgets	79
5.2.3	SmartSense hardware parameters-only mode	79
5.2.4	SmartSense for initial tuning	79
5.3	Manual tuning	80
5.3.1	Overview	80
5.3.2	CSD sensing method (third- and fourth-generation)	81
5.3.2.1	Basics	82
5.3.2.1.1	Conversion gain and CAPSENSE™ signal	82
5.3.2.1.2	Flat-spots	86
5.3.2.2	Selecting CAPSENSE™ hardware parameters	87
5.3.2.2.1	Using SmartSense to determine hardware parameters	87
5.3.2.2.2	Manually tuning hardware parameters	88
5.3.2.2.3	Tuning shield electrode	91
5.3.2.3	Selecting CAPSENSE™ software parameters	93
5.3.2.3.1	Baseline	94
5.3.2.3.2	Baseline update algorithm	94
5.3.2.3.3	Finger threshold	95
5.3.2.3.4	Hysteresis	96
5.3.2.3.5	Noise threshold	96
5.3.2.3.6	Negative noise threshold	96
5.3.2.3.7	Low baseline reset	97
5.3.2.3.8	Debounce	97
5.3.2.3.9	Sensor auto reset	97
5.3.2.3.10	Multi-frequency scan	98
5.3.2.4	Button widget tuning	98

Table of contents

5.3.2.5	Slider widget tuning	100
5.3.2.6	Touchpad widget tuning	103
5.3.2.7	Proximity widget tuning	103
5.3.3	CSX sensing method (third- and fourth-generation)	103
5.3.3.1	Basics	103
5.3.3.1.1	Conversion gain and CAPSENSE signal	103
5.3.3.2	Selecting CAPSENSE™ hardware parameters	105
5.3.3.2.1	Tx clock parameters	105
5.3.3.2.2	Modulator clock frequency	106
5.3.3.2.3	IDAC	106
5.3.3.2.4	Number of sub-conversions	107
5.3.3.3	Selecting CAPSENSE™ software parameters	107
5.3.3.4	Button widget tuning	107
5.3.3.5	Touchpad widget tuning	109
5.3.4	CSD-RM sensing method (fifth-generation and fifth-generation low-power)	109
5.3.4.1	Basics	109
5.3.4.1.1	Conversion gain and CAPSENSE™ signal	109
5.3.4.1.2	Flat-spots	114
5.3.4.2	Selecting CAPSENSE™ hardware parameters	115
5.3.4.2.1	Using SmartSense to determine hardware parameters	116
5.3.4.2.2	Manually tuning hardware parameters	117
5.3.4.2.3	Tuning shield electrode	122
5.3.4.2.4	Selecting CAPSENSE™ software parameters	126
5.3.4.2.5	Configuring autonomous scan	126
5.3.4.2.6	Multi-channel scanning	131
5.3.4.2.7	Button widget tuning	133
5.3.4.2.8	Slider widget tuning	133
5.3.4.2.9	Touchpad widget tuning	133
5.3.4.2.10	Proximity widget example	133
5.3.4.2.11	Low-power widget tuning	134
5.3.5	CSX-RM sensing method (fifth-generation and fifth-generation low-power)	134
5.3.5.1	Basics	134
5.3.5.1.1	Conversion gain and CAPSENSE™ signal	134
5.3.5.2	Selecting CAPSENSE™ hardware parameters	136
5.3.5.2.1	Scan mode	136
5.3.5.2.2	Sensor connection method	136
5.3.5.2.3	Modulator clock frequency	137
5.3.5.2.4	Initialization sub-conversions	137
5.3.5.2.5	Tx clock parameters	137
5.3.5.2.6	Number of sub-conversions	139
5.3.5.2.7	Capacitive DACs	139
5.3.5.2.8	Compensation CDAC divider	140



Table of contents

5.3.5.2.9 Auto-calibration 140

5.3.5.2.10 Selecting CDAC codes 140

5.3.5.2.11 CDAC dither 140

5.3.5.2.12 Fine CDAC 141

5.3.5.3 Selecting CAPSENSE™ software parameters 141

5.3.5.4 Configuring autonomous scan 141

5.3.5.5 Multi-channel scanning 141

5.3.5.6 Button widget tuning 141

5.3.5.7 Touchpad widget tuning 141

5.3.6 Manual tuning trade-offs 141

5.3.6.1 Reliability 142

5.3.6.2 Power consumption and response time 142

5.3.7 Tuning debug FAQs 143

5.3.7.1 The tuner does not communicate with the device 143

5.3.7.2 I am unable to update parameters on my device through the tuner 143

5.3.7.3 I can connect to the device but I do not see any raw counts 143

5.3.7.4 Difference counts only change slightly (10 to 20 counts) when a finger is placed on the sensor 143

5.3.7.5 After tuning the system, I see large amount of radiated noise during testing 144

5.3.7.6 My scan time no longer meets system requirements after manual tuning 144

5.3.7.7 I am unable to calibrate my system to 85 percent 144

5.3.7.8 My slider centroid response is non-linear 145

5.3.7.9 My slider segments have a large variation of CP 145

5.3.7.10 Raw counts show a level-shift or increased noise when GPIOs are toggled 145

5.3.7.11 I am getting a low SNR 147

5.3.7.12 I am observing a low CM for my CSX button 148

6 Gesture in CAPSENSE™ 151

6.1 Touch gesture support 151

6.2 Gesture groups 151

6.3 One-finger gesture implementation 151

6.3.1 Tuning the widget 151

6.3.2 Selecting predefined gesture 152

6.3.3 Firmware implementation with timestamp 153

6.3.4 Tuning gesture parameters 153

6.3.4.1 Using tuner GUI for tuning gesture parameters 153

6.3.4.2 Click 155

6.3.4.2.1 Single click 156

6.3.4.2.2 Double click 157

6.3.4.3 Scroll 157

6.3.4.3.1 One-finger scroll 158

6.3.4.3.2 One-finger inertial scroll 159

6.3.4.4 One-finger flick 159

Table of contents

6.3.5	Two-finger gesture implementation	159
6.3.6	Advanced filters for gestures	160
7	Design considerations	161
7.1	Firmware	161
7.1.1	Low-power design	163
7.1.2	Synchronized scanning	165
7.2	Sensor construction	167
7.3	Overlay selection	168
7.3.1	Overlay material	168
7.3.2	Overlay thickness	169
7.3.3	Overlay adhesives	170
7.4	PCB layout guidelines	170
7.4.1	Sensor CP	170
7.4.2	Board layers	170
7.4.3	Button design	171
7.4.3.1	Self-capacitance button design	171
7.4.3.2	Mutual-capacitance button design	172
7.4.3.2.1	Fishbone pattern	172
7.4.3.2.2	Button design for arbitrary shapes and dimensions	173
7.4.3.2.3	General recommendations on Fishbone pattern parameters	175
7.4.4	Slider design	178
7.4.4.1	Slider-segment shape, width, and Air gap	179
7.4.4.2	Dummy segments at the ends of a slider	185
7.4.4.3	Deciding slider dimensions	185
7.4.4.4	Routing slider segment trace	186
7.4.4.5	Slider design with LEDs	187
7.4.5	Sensor and device placement	187
7.4.6	Trace length and width	187
7.4.7	Trace routing	188
7.4.8	Crosstalk solutions	190
7.4.9	Vias	190
7.4.10	Ground plane	191
7.4.10.1	Using packages without E-pad	192
7.4.10.2	Using packages with E-pad	194
7.4.10.3	Using PSoC™ 4 Bluetooth® LE devices	194
7.4.11	Power supply layout recommendations	196
7.4.12	Layout guidelines for liquid tolerance	197
7.4.12.1	Layout guidelines for shield electrode	197
7.4.12.2	Layout guidelines for guard sensor	199
7.4.12.3	Liquid tolerance with ground ring	200
7.4.13	Schematic rule checklist	200
7.4.13.1	External capacitors pin selection	201

Table of contents

7.4.13.2	Sensor pin selection	203
7.4.14	Layout rule checklist	205
7.5	Noise in CAPSENSE™ system	208
7.5.1	Finger injected noise	208
7.5.1.1	Recommendations to reduce the finger injected noise	209
7.5.2	VDDA noise	210
7.5.2.1	Recommendations to reduce the VDDA noise	211
7.5.3	External noise	211
7.5.3.1	ESD protection	211
7.5.3.1.1	Preventing ESD discharge	211
7.5.3.1.2	Redirect	212
7.5.3.1.3	ESD protection devices	212
7.5.3.2	Electromagnetic compatibility (EMC) considerations	213
7.5.3.2.1	Radiated interference and emissions	213
7.5.3.2.2	Conducted RF noise	227
7.6	Effect of grounding	227
7.6.1	CSX method	227
7.6.1.1	CbodyDG>>Cfs	228
7.6.1.2	CbodyDG<<Cfs	229
7.6.2	CSD method	230
7.6.2.1	AC/DC-powered application	230
7.6.2.2	Battery-powered application	231
8	CAPSENSE™ Plus	232
9	Resources	237
9.1	Website	237
9.2	Device datasheet	237
9.3	Component datasheet/middleware document	237
9.4	Technical reference manual	237
9.5	Development kits	237
9.6	PSoC™ Creator	237
9.7	ModusToolbox™	237
9.8	Application notes and design guides	238
9.9	Design support	238
	Glossary	239
	Revision history	245
	Disclaimer	249

1 Introduction

1 Introduction

1.1 Overview

Capacitive touch sensors are user interface devices that use human body capacitance to detect the presence of a finger on or near a sensor. CAPSENSE™ solutions bring elegant, reliable, and easy-to-use capacitive touch sensing functionality to your product.

This design guide focuses on the CAPSENSE™ feature in the PSoC™ 4 and PSoC™ 6 MCU families of devices. These are true programmable embedded system-on-chip, integrating configurable analog and digital peripheral functions, memory, radio, and a microcontroller on a single chip. These devices are highly flexible and can implement many functions such as ADC, DAC, and Bluetooth® LE in addition to CAPSENSE™, which accelerates time-to-market, integrates critical system functions, and reduces overall system cost.

This guide assumes that you are familiar with developing applications for PSoC™ 4 and PSoC™ 6 MCU using the PSoC™ Creator integrated design environment (IDE). If you are new to PSoC™ 4, see [AN79953 - Getting started with PSoC™ 4](#) or [AN91267 - Getting started with PSoC™ 4 Bluetooth® LE](#). If you are new to PSoC™ 6 MCU, see [AN221774 – Getting started with PSoC™ 6 MCU](#) and [AN210781 - Getting started with PSoC™ 6 MCU with Bluetooth® LE connectivity](#). If you are new to PSoC™ Creator, see the [PSoC™ Creator home page](#).

If you are new to ModusToolbox™, see [ModusToolbox™ IDE quick start guide](#).

This design guide helps you understand:

- [CAPSENSE™ technology in PSoC™ 4 and PSoC™ 6 MCU](#)
- [Design and development tools available for PSoC™ 4 and PSoC™ 6 MCU](#)
- [PSoC™ 6 MCU CAPSENSE™ PCB layout guidelines for PSoC 4 and PSoC 6 MCU](#)
- [Performance tuning of PSoC™ 4 and PSoC™ 6 MCU CAPSENSE™ component](#)
- [Applications using CAPSENSE™ Plus features such as motor control systems and induction cookers](#)

1.2 CAPSENSE™ features

CAPSENSE™ in PSoC™ 4 and PSoC™ 6 MCU has the following features:

- Supports self-capacitance (CSD) and mutual-capacitance (CSX) based touch sensing on all CAPSENSE™-capable GPIO pins¹⁾
- Provides the best-in-class signal-to-noise ratio (SNR), allowing high sensitivity that provides high-range proximity sensing (up to a 30-cm proximity-sensing distance) and liquid-tolerant operation (see [Liquid tolerance](#))
- High-performance sensing across a variety of overlay materials and varied thickness (see [CAPSENSE™ fundamentals](#), [Overlay material](#), and [Overlay thickness](#))
- [SmartSense](#) auto-tuning technology
- Pseudo random sequence (PRS) clock source, supports spread spectrum and programmable resistance switches for lower electromagnetic interference (EMI)
- Low power consumption with as low as 1.71-V operation and as low as 150-nA current consumption in Hibernate mode

The PSoC™ 4100S Max device introduces the fifth-generation CAPSENSE™ technology ([Ratiometric sensing technology](#)) and has the following additional features when compared to older generations:

- **Improved SNR:** Fifth-generation CAPSENSE™ technology ([Ratiometric sensing technology](#)) significantly improves noise performance compared to previous generation devices

¹⁾ To achieve the best CAPSENSE™ performance, follow the recommendations in the [Sensor pin selection](#) section

1 Introduction

- **Improved refresh rate:** The better sensitivity of multi sense converter (MSC) requires less time to get a similar signal as in previous generations; therefore, it is able to achieve a higher refresh rate. The two independent MSC blocks, which can scan the sensors in parallel improve the refresh rate further especially in use cases where large numbers of sensors need to be scanned
- **Improved CPU bandwidth:** Scan supported in both CPU mode and DMA mode. The CPU mode is a conventional interrupt-driven mode, while the DMA mode is capable of autonomous scanning which reduces the CPU bandwidth requirement to 18% compared to previous generations
- **Improved noise immunity:** Rail-to-rail swing is used as sense voltage, which provides maximum sense voltage and better immunity. In the fifth-generation CAPSENSE™ technology, full-wave differential sensing is used for self-capacitance sensing and this cancels out noise induced from the external environment to the sensor routings. This sensing technology is also better immune to power supply (V_{dd}) noise

The PSoC™ 4000T device is a member of the PSoC™ 4 MCU family with fifth-generation CAPSENSE™ and multi-sense technology. It offers an ultra-low power touch HMI solution, based on an integrated “Always-On” sensing technology, improved performance to enable modern sleek user interface solutions with superior liquid tolerance, and robust and reliable touch HMI solutions for harsh environments.

1.3 PSoC™ 4 and PSoC™ 6 MCU CAPSENSE™ Plus features

You can create PSoC™ 4 CAPSENSE™ Plus applications that feature capacitive touch sensing and additional system functionality. The key features of these devices, in addition to CAPSENSE™ are:

- Arm® Cortex®-M0/M0+ CPU with single cycle multiply delivering up to 43 DMIPS at 48 MHz
- 1.71 V – 5.5 V operation over –40 to 85°C ambient
- Up to 128 KB of flash (CM0+ has > 2X code density over 8-bit solutions)
- Up to 16 KB of SRAM
- Up to 94 programmable GPIOs
- Independent center-aligned PWMs with complementary dead-band programmable outputs, synchronized ADC operation (ability to trigger the ADC at a customer-specifiable time in the PWM cycle), and synchronous refresh (ability to synchronize PWM duty cycle changes across all PWMs to avoid anomalous waveforms)
- Comparator-based triggering of PWM Kill signals (to terminate motor-driving when an over-current condition is detected)
- 12-bit 1 Msps ADC including sample-and-hold (S&H) capability with zero-overhead sequencing allowing the entire ADC bandwidth to be used for signal conversion and none used for sequencer overhead
- Opamps with comparator mode and SAR input buffering capability
- Segment LCD direct drive that supports up to four commons
- SPI/UART/I2C serial communication channels
- Bluetooth® LE communication compliant with version 4.0 and multiple features of version 4.1
- Programmable logic blocks, each having eight macrocells and a cascadable data path, called universal digital blocks (UDBs) for efficient implementation of programmable peripherals (such as I2S)
- Controller area network (CAN)
- Fully-supported PSoC™ Creator design entry, development, and debug environment providing:
 - Design entry and build (comprehending analog routing)
 - Components for all fixed-function peripherals and common programmable peripherals
 - Documentation and training modules
- Support for porting builds to MDK Arm® environment (previously known as RealView) and others
- Support for Eclipse integrated development environment (IDE) for ModusToolbox™

The main features of PSoC™ 6 MCU device, in addition to CAPSENSE™ are:

1 Introduction

- Single CPU devices (Arm® Cortex® -M4), dual CPU devices (Arm® Cortex® -M4 and Cortex® -M0+). Support for inter-processor communication in hardware
- 1.71 V - 3.6 V device operating voltage with user selectable core logic operation at either 1.1 V or 0.9 V
- Up to 2 MB of flash memory and up to 1 MB of SRAM
- Up to 78 GPIOs that can be used for analog, digital, CAPSENSE™, or segment LCD functions
- Programmable analog blocks: Two opamps, configurable PGAs, comparators, 12-bit 1 Msps SAR ADC, 12-bit voltage mode DAC
- Programmable digital blocks, communication interfaces
- 12 UDBs, 32 TCPWMs configurable as 16-bit/32-bit timer, counter, PWM, or quadrature decoder
- Up to 13 serial communication block (SCB) configurable as I2C, SPI, or UART interfaces. See the [Device datasheet](#) for more details
- Audio subsystem with one I2S interface and two PDM channels
- SMIF interface with support for execute-in-place from external quad SPI flash memory and on-the-fly encryption and decryption
- Bluetooth® Smart connectivity with Bluetooth® LE 5.0 (applicable only to PSoC™ 6 MCU with Bluetooth® LE family of devices)

See [AN64846 - Getting started with CAPSENSE™](#) to select an appropriate CAPSENSE™ device based on your requirements.

1.4 CAPSENSE™ design flow

[Figure 1](#) illustrates the product design cycle with capacitive sensing; the information in this guide is highlighted in green. provides links to the supporting documents for each of the numbered tasks in [Figure 1](#).

1 Introduction

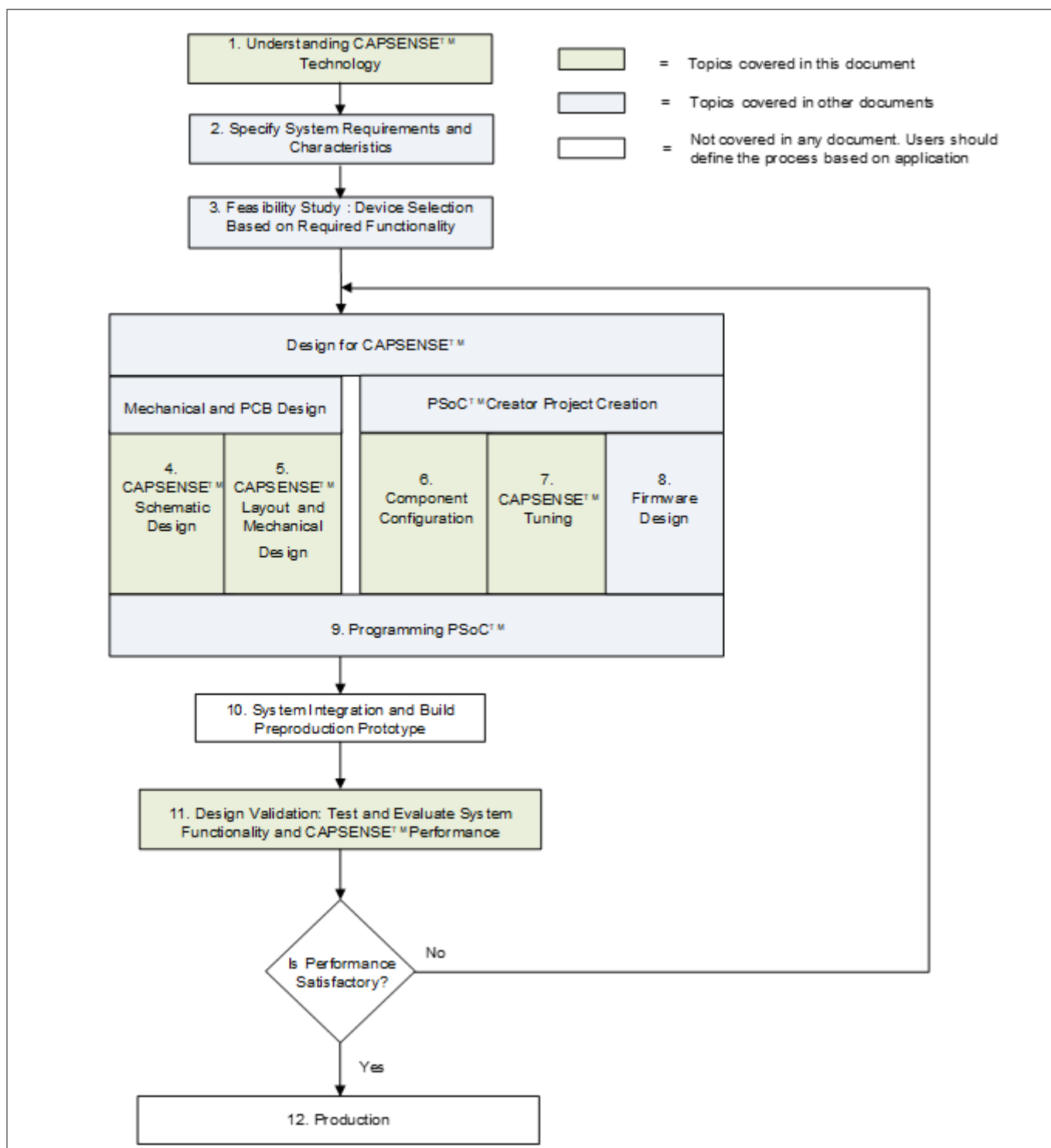

Figure 1 CAPSENSE™ product design flow

Table 1 Supporting documentation

Steps in flowchart	Supporting documentation	
	Name	Chapter
1. Understanding CAPSENSE™	CAPSENSE™ design guide (This document) Getting started with CAPSENSE™	Chapter 2 and Chapter 3 –

(table continues...)

1 Introduction

Table 1 (continued) Supporting documentation

Steps in flowchart	Supporting documentation	
	Name	Chapter
2. Specify requirements	Getting started with CAPSENSE™	–
3. Feasibility study	PSoC™ 4 datasheet PSoC™ 4 Bluetooth® LE datasheet PSoC™ 6 MCU datasheet	–
	AN64846 – Getting started with CAPSENSE™ design guide AN79953 – Getting started with PSoC™ 4 AN91267 – Getting started with PSoC™ 4 Bluetooth® LE AN221774 – Getting started with PSoC™ 6 MCU	–
4. Schematic design	CAPSENSE™ design guide (This document)	Chapter 7
5. Layout design	CAPSENSE™ design guide (This document)	Chapter 7
6. Component configuration	PSoc™ CAPSENSE™ Component datasheet/middleware document	–
	CAPSENSE™ design guide (This document)	Chapter 5
7. Performance tuning	PSoc™ CAPSENSE™ design guide (This document)	Chapter 5
8. Firmware design	PSoC™ Component datasheet/middleware document	–
	PSoC™ Creator Example projects Download ModusToolbox™ here . See the ModusToolbox™ related documents: ModusToolbox™ release notes ModusToolbox™ user guide ModusToolbox™ quick start guide ModusToolbox™ CAPSENSE™ configurator guide ModusToolbox™ CAPSENSE™ tuner guide PSoC™ Creator to ModusToolbox™ porting guide	–
9. Programming PSoC™	PSoC™ Creator user guide for in-IDE programming PSoC™ Programmer home page and MiniProg3 user guide for standalone programming	–
10. Prototype	–	–
11. Design validation	CAPSENSE™ design guide (This document)	Chapter 5
12. Production	–	–

2 CAPSENSE™ technology

2 CAPSENSE™ technology

Capacitive touch sensing technology measures changes in capacitance between a plate (the sensor) and its environment to detect the presence of a finger on or near a touch surface.

2.1 CAPSENSE™ fundamentals

A typical CAPSENSE™ sensor consists of a copper pad of proper shape and size etched on the surface of a PCB. A non-conductive overlay serves as the touch surface for the button, as [Figure 2](#) shows.

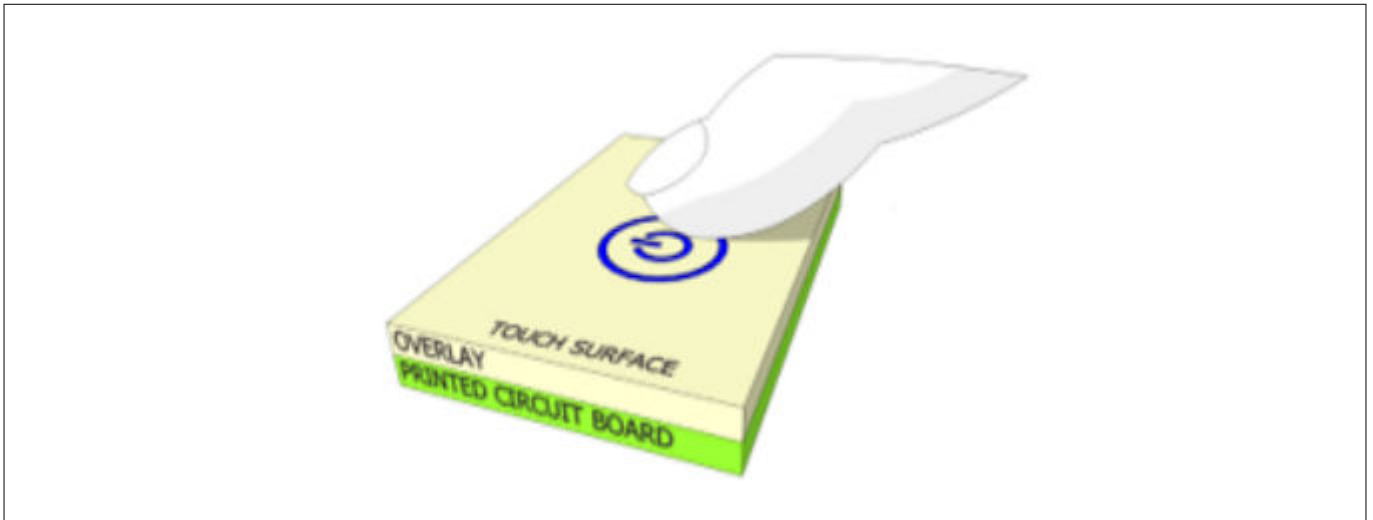

Figure 2 Capacitive touch sensor

PCB traces and vias connect the sensor pads to PSoC™ GPIOs that are configured as CAPSENSE™ sensor pins. As [Figure 3](#) shows, the self-capacitance of each electrode is modeled as C_{SX} and the mutual capacitance between electrodes is modeled as C_{MX} . CAPSENSE™ circuitry internal to the PSoC™ converts these capacitance values into equivalent digital counts (see [Chapter 3](#) for details). These digital counts are then processed by the CPU to detect touches.

CAPSENSE™ also requires external capacitor C_{MOD} or C_{INT} for self-capacitance sensing and mutual-capacitance sensing. For third- and fourth-generation CAPSENSE™ architecture, a single C_{MOD} capacitor is required for self-capacitance sensing and C_{INTA} and C_{INTB} capacitors for mutual-capacitance sensing. If shield electrode is implemented for liquid tolerance, or for large proximity sensing distance, an additional C_{TANK} capacitor may be required. For Fifth-Generation CAPSENSE™ architecture, two C_{MOD} capacitors are required for both self-capacitance and mutual-capacitance sensing for each channel. These external capacitors are connected between a dedicated GPIO pin and ground. [Table 36](#) list the recommended values of the external capacitors.

2 CAPSENSE™ technology

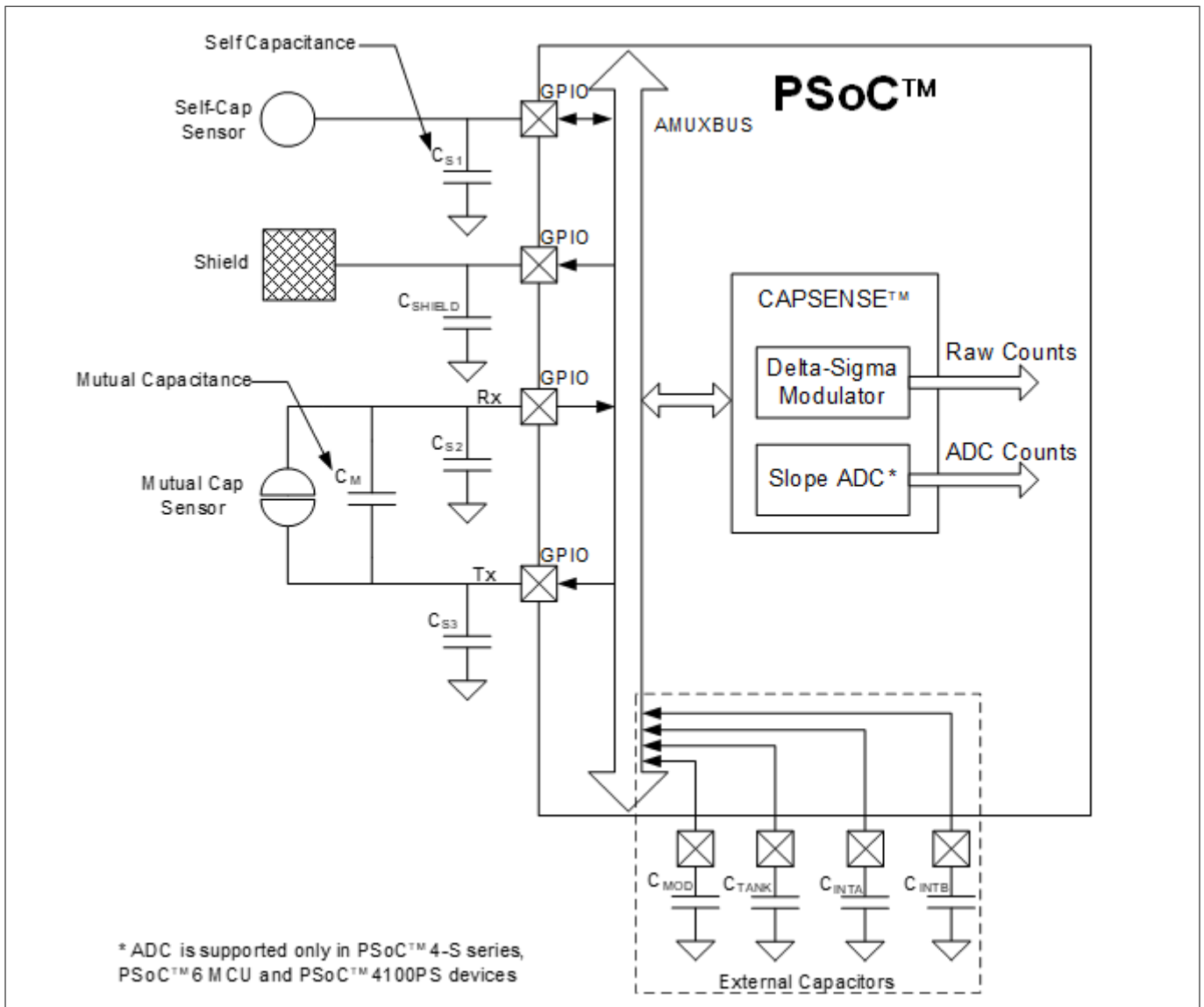

Figure 3 PSoC™ device, sensors, and external capacitors

The capacitance of the sensor in the absence of a touch is called the parasitic capacitance, C_p . C_p results from the electric field between the sensor (including the sensor pad, traces, and vias) and other conductors in the system such as the ground planes, traces, and any metal in the product’s chassis or enclosure. The GPIO and internal capacitances of PSoC™ also contribute to the parasitic capacitance. However, these internal capacitances are typically very small compared to the sensor capacitance.

2.1.1 Self-capacitance sensing

Figure 4 shows how a GPIO pin is connected to a sensor pad by traces and vias for self-capacitance sensing. Typically, a ground (GND) hatch surrounds the sensor pad to isolate it from other sensors and traces. Although Figure 4 shows some field lines around the sensor pad, the actual electric field distribution is very complex.

2 CAPSENSE™ technology

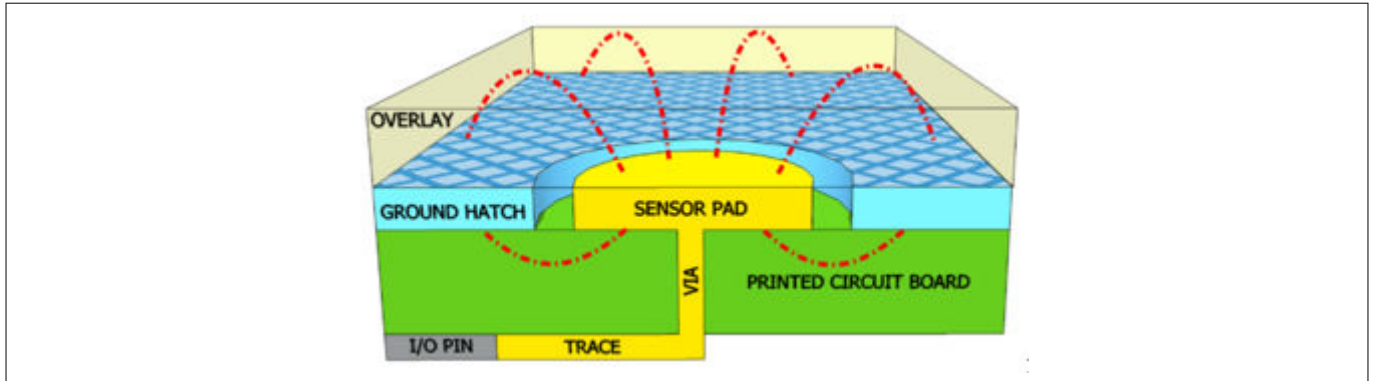

Figure 4 Parasitic capacitance

When a finger is present on the overlay, the conductive nature and large mass of the human body forms a grounded, conductive plane parallel to the sensor pad, as Figure 5 shows.

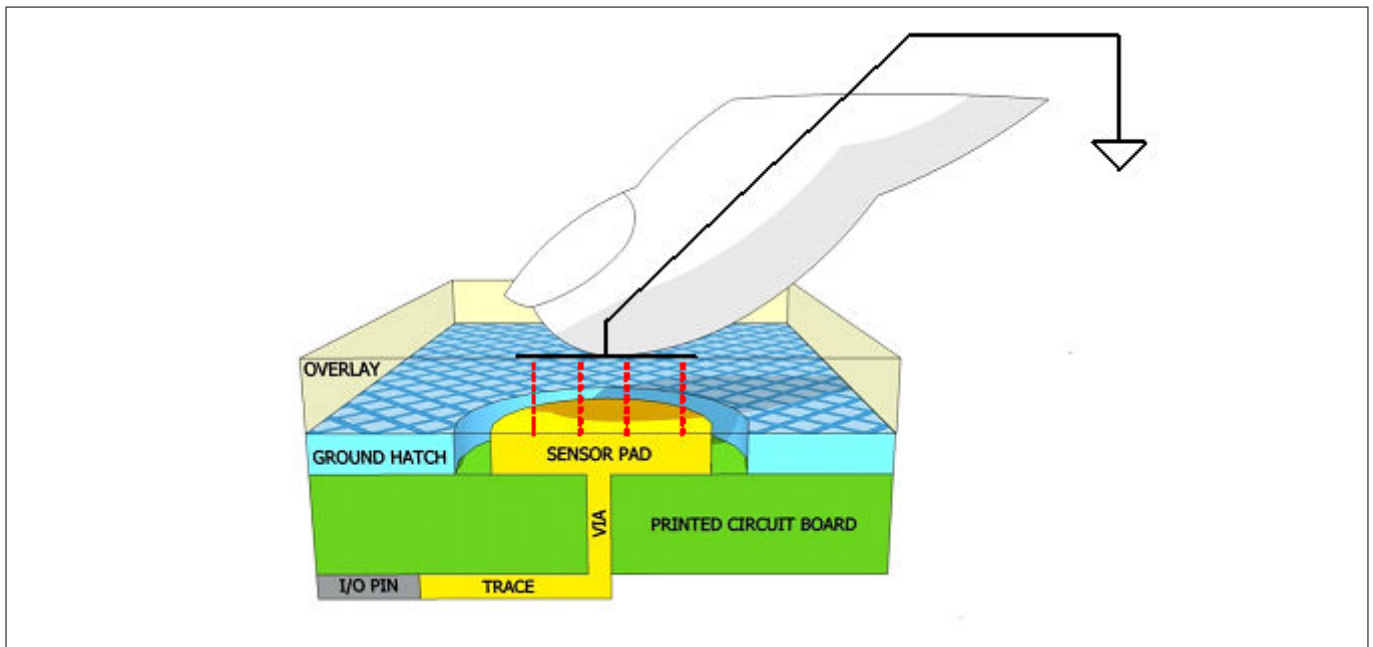

Figure 5 Finger capacitance

This arrangement forms a parallel plate capacitor. The capacitance between the sensor pad and the finger is shown in Equation 1.

$$C_F = \frac{\epsilon_0 \epsilon_r A}{d}$$

Equation 1 Finger capacitance

Where:

ϵ_0 = Free space permittivity

ϵ_r = Relative permittivity of overlay

A = Area of finger and sensor pad overlap

d = Thickness of the overlay

C_F = Finger capacitance.

2 CAPSENSE™ technology

C_P and C_F are parallel to each other because both represent the capacitance between the sensor pin and ground. Therefore, the total capacitance C_S of the sensor, when the finger is present on the sensor, is the sum of C_P and C_F .

$$C_S = C_P + C_F$$

Equation 2 Total sense capacitance when finger is present on sensor

In the absence of touch, C_S is equal to C_P .

PSoC™ converts the capacitance C_S into equivalent digital counts called raw counts. Because a finger touch increases the total capacitance of the sensor pin, an increase in the raw counts indicates a finger touch. Refer to the CSD specification in [Device datasheet/Component datasheet/middleware document](#) document to learn about the supported CP range for a given device with which the recommended SNR can be achieved.

2.1.2 Mutual-capacitance sensing

Figure 6 shows the button sensor layout for mutual-capacitance sensing. Mutual-capacitance sensing measures the capacitance between two electrodes, transmit (Tx) electrode and receive (Rx) electrode.

In a mutual-capacitance sensing system, a digital voltage signal switching between VDDIO²⁾ or VDDD³⁾ (if VDDIO is not supported by the device) and GND is applied to the Tx pin and the amount of charge received on the Rx pin is measured. The amount of charge received on the Rx electrode is directly proportional to the mutual-capacitance (C_M) between the two electrodes.

When a finger is placed between the Tx and Rx electrodes, the mutual-capacitance decreases to C_M^1 , as shown in Figure 7. Because of the reduction in the mutual-capacitance, the charge received on the Rx electrode also decreases. The CAPSENSE™ system measures the amount of charge received on the Rx electrode to detect a touch/no touch condition.

²⁾

³⁾ VDDD is the device power supply for digital section.

2 CAPSENSE™ technology

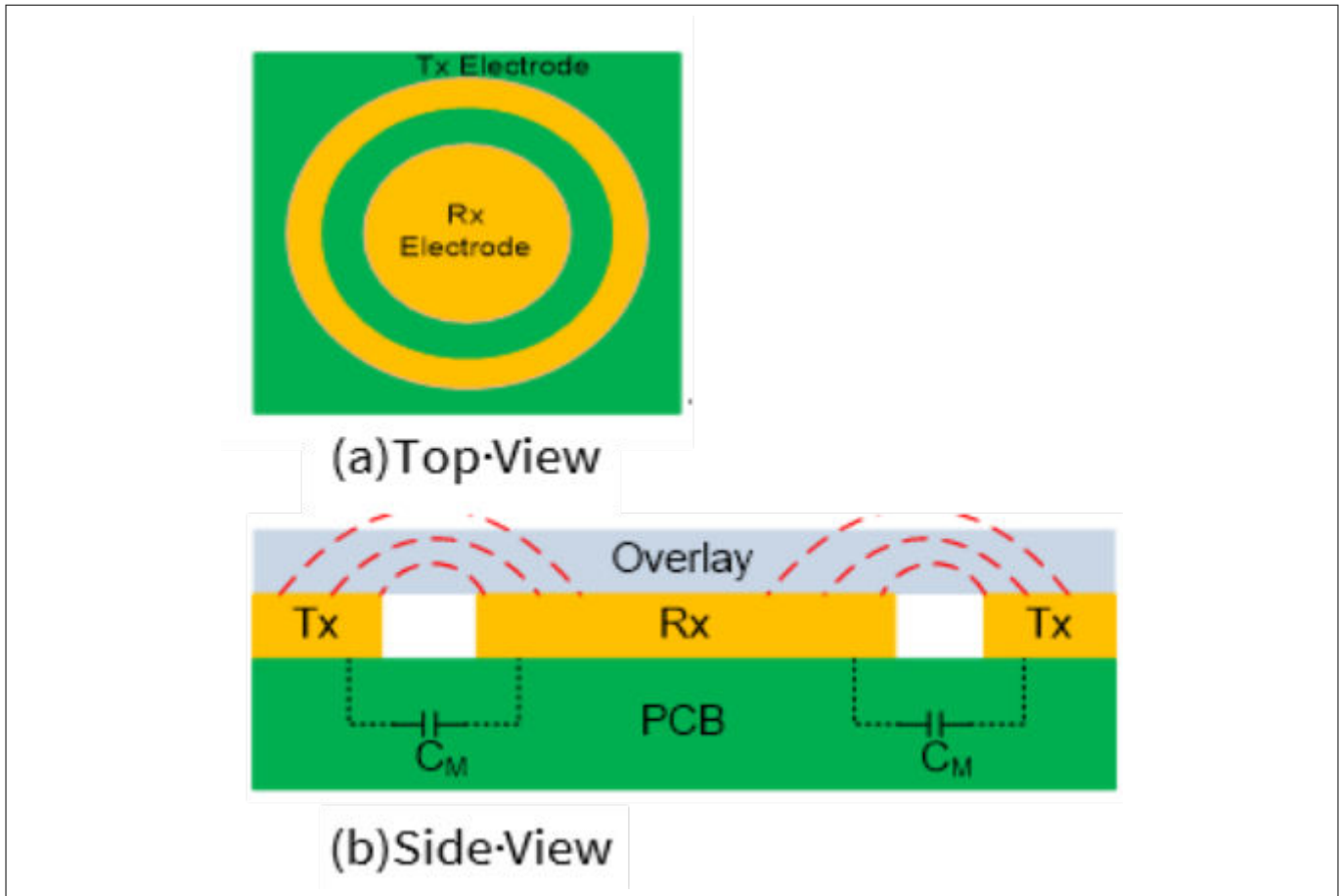

Figure 6 Mutual-capacitance sensing

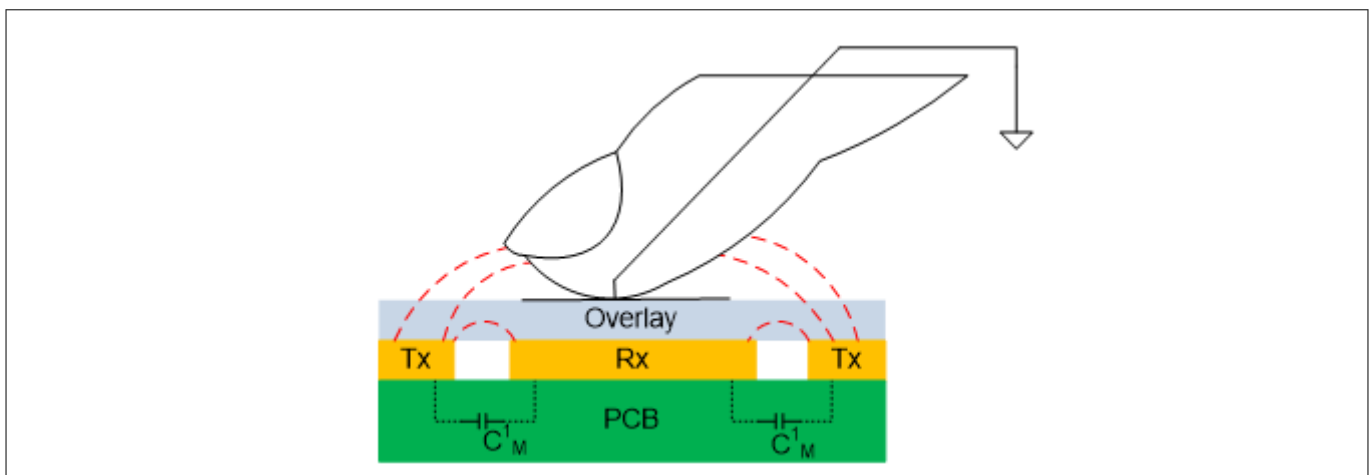

Figure 7 Mutual-capacitance with finger touch

2.2 Capacitive touch sensing method

PSoC™ uses patented capacitive touch-sensing method CAPSENSE™ sigma delta (CSD) for self-capacitance sensing and CAPSENSE™ crosspoint (CSX) for mutual-capacitance scanning. The CSD and CSX touch sensing methods provide the industry’s best-in-class [Signal-to-noise ratio \(SNR\)](#). These sensing methods are a combination of hardware and firmware techniques.

2 CAPSENSE™ technology

2.2.1 CAPSENSE™ sigma delta (CSD)

Figure 8 shows a simplified block diagram of the CSD method.

In CSD, each GPIO has a switched-capacitance circuit that converts C_s into an equivalent current. An analog MUX (AMUX) selects one of the sensor currents and feeds it into the current to digital converter. The current to digital converter is similar to a delta sigma ADC. The output count of the current to digital converter, known as raw count, is a digital value that is proportional to the self-capacitance between the electrodes.

$$\text{raw count} = G_{CSD} C_s$$

Equation 3 Raw count and sensor capacitance relationship in CSD

Where,

G_{CSD} = Capacitance to digital conversion gain of CSD

C_s = Self-capacitance of the electrode

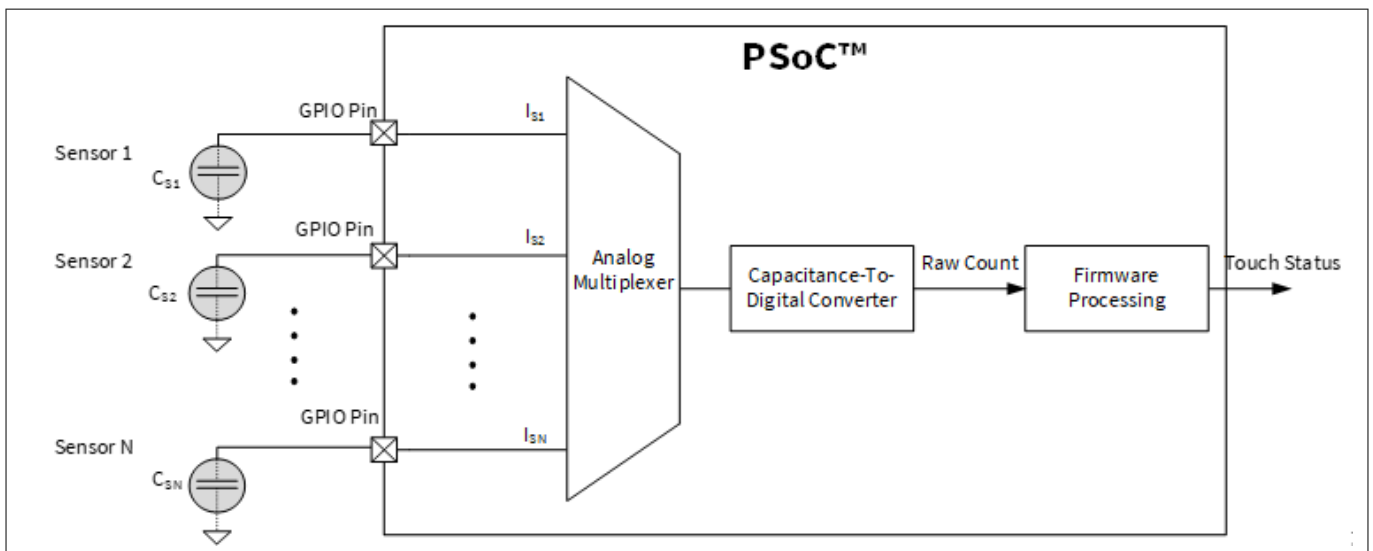

Figure 8 Simplified diagram of CSD method

Figure 10 illustrates a plot of raw count over time. When a finger touches the sensor, the C_s increases from C_p to $C_p + C_f$, and the raw count increases. By comparing the change in raw count to a predetermined threshold, logic in firmware decides whether the sensor is active (finger is present).

2.2.2 CAPSENSE™ crosspoint (CSX)

Figure 9 shows the simplified block diagram of the CSX method.

2 CAPSENSE™ technology

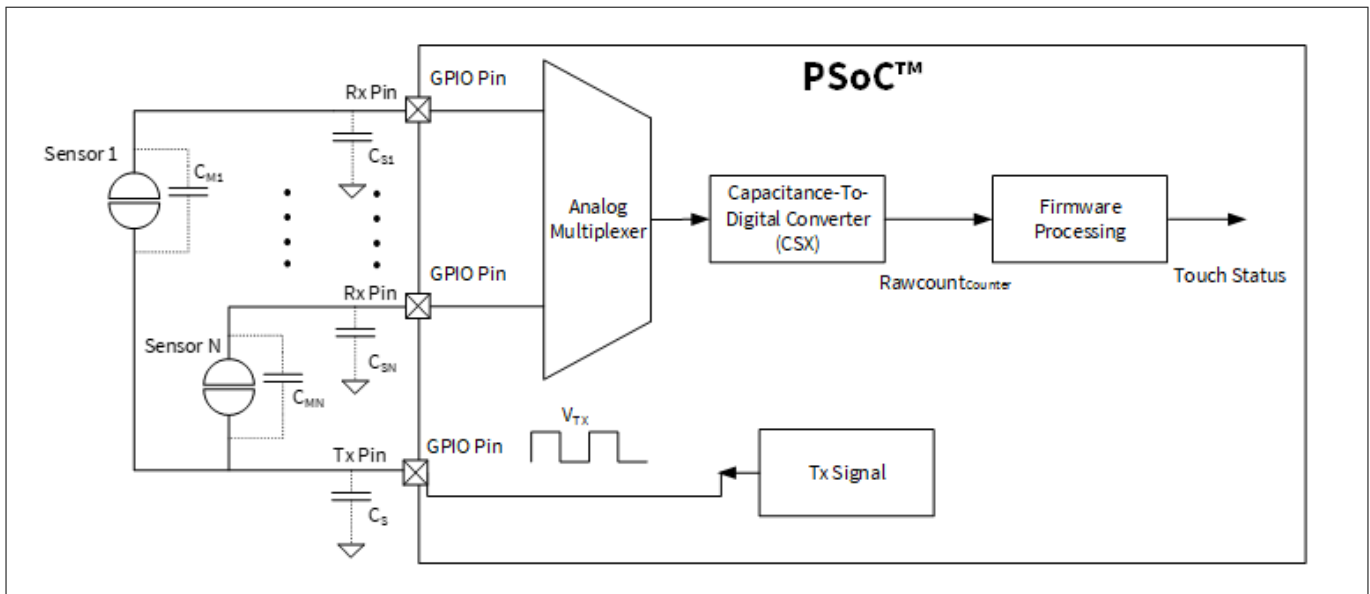

Figure 9 Simplified diagram of CAPSENSE™ crosspoint (CSX) method

With CSX, a voltage on the Tx electrode couples charge on to the RX electrode. This charge is proportional to the mutual capacitance between the Tx and Rx electrodes. An analog MUX then selects one of the Rx electrodes and feeds it into the current to digital converter.

The output count of the current to digital converter, $Rawcount_{Counter}$, is a digital value that is proportional to the mutual-capacitance between the Rx and Tx electrodes as shown in Equation 4.

$$Rawcount_{Counter} = G_{CSX} C_M$$

Equation 4 Raw count and sensor capacitance relationship in CSX

Where,

G_{CSX} = Capacitance to digital conversion gain of mutual capacitance method

C_M = Mutual-capacitance between two electrodes

Figure 10 illustrates a plot of raw count over time. When a finger touches the sensor, C_M decreases from C_M to C_M^1 (see Figure 7) hence the counter output decreases. The firmware normalizes the raw count such that the raw counts go high when C_M decreases. This maintains the same visual representation of raw count between CSD and CSX methods. By comparing the change in raw count to a predetermined threshold, logic in firmware decides whether the sensor is active (finger is present). The normalized inverted raw count is computed using Equation 15.

2 CAPSENSE™ technology

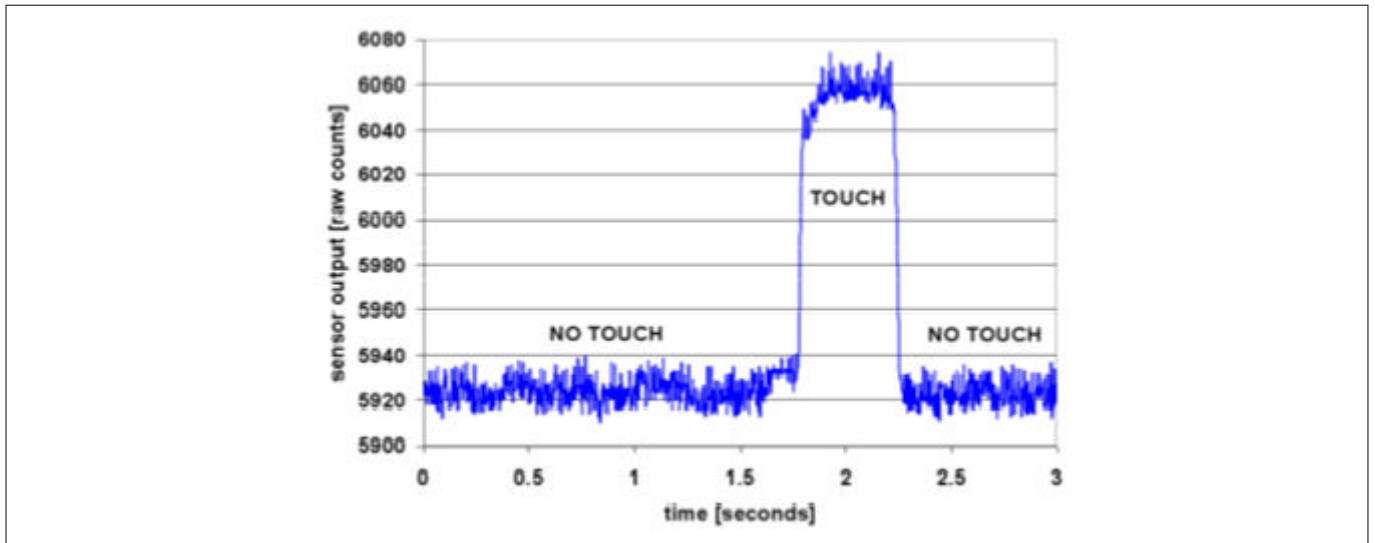

Figure 10 Raw count versus time

For an in-depth discussion of the PSoC™ 4 and PSoC™ 6 CAPSENSE™ CSD and CSX blocks, see chapter [PSoC™ 4 and PSoC™ 6 MCU CAPSENSE™](#).

2.3 Signal-to-noise ratio (SNR)

In practice, the raw counts vary due to inherent noise in the system. CAPSENSE™ noise is the peak-to-peak variation in raw counts in the absence of a touch, as [Figure 11](#) shows.

A well-tuned CAPSENSE™ system reliably discriminates between the ON and OFF states of the sensors. To achieve good performance, the CAPSENSE™ signal must be significantly larger than the CAPSENSE™ noise. SNR is defined as the ratio of CAPSENSE™ signal to CAPSENSE™ noise is the most important performance parameter of a CAPSENSE™ sensor.

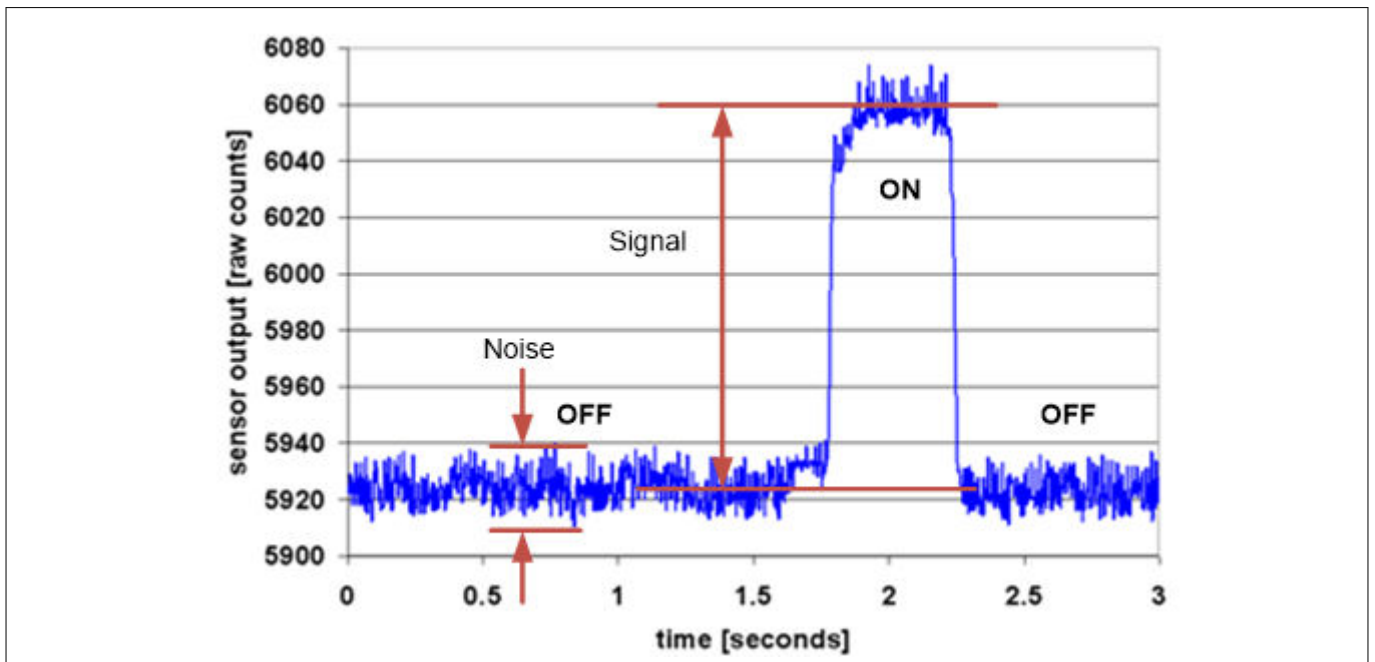

Figure 11 SNR

In this example, the average level of raw count in the absence of a touch is 5925 counts. When a finger is placed on the sensor, the average raw count increases to 6060 counts, which means the signal is $6060 - 5925 = 135$

2 CAPSENSE™ technology

counts. The minimum value of the raw count in the OFF state is 5912 and the maximum value is 5938 counts. Therefore, the CAPSENSE™ noise is $5938 - 5912 = 26$ counts. This results in an SNR of $135/26 = 5.2$.

The minimum SNR recommended for a CAPSENSE™ sensor is 5. This 5:1 ratio comes from best practice threshold settings, which enable enough margin between signal and noise in order to provide reliable ON/OFF operation.

2.4 CAPSENSE™ widgets

CAPSENSE™ widgets consist of one or more CAPSENSE™ sensors, which as a unit represent a certain type of user interface. CAPSENSE™ widgets are broadly classified into four categories – buttons (zero-dimensional), sliders (one-dimensional), touchpads/trackpads (two-dimensional), and proximity sensors (three-dimensional). Figure 12 shows button, slider, and proximity sensor widgets. This section explains the basic concepts of different CAPSENSE™ widgets. For a detailed explanation of sensor construction, see [Sensor construction](#).



Figure 12 Several types of widgets

2.4.1 Buttons (zero-dimensional)

CAPSENSE™ buttons replace mechanical buttons in a wide variety of applications such as home appliances, medical devices, white goods, lighting controls, and many other products. It is the simplest type of CAPSENSE™ widget, consisting of a single sensor. A CAPSENSE™ button gives one of two possible output states: active (finger is present) or inactive (finger is not present). These two states are also called ON and OFF states, respectively.

For the self-capacitance (CSD) sensing method, a simple CAPSENSE™ button consists of a circular copper pad connected to a PSoC™ GPIO with a PCB trace. The CAPSENSE™ button is surrounded by grounded copper hatch that isolates it from other buttons and traces. A circular gap separates the button pad and the ground hatch. Each button requires one PSoC™ GPIO. These buttons can be constructed using any conductive material on a non-conductive substrate; for example, indium tin oxide on a glass substrate, or silver ink on a non-conductive film. Even metallic springs can be used as button sensors; see [Sensor construction](#) for more details.

2 CAPSENSE™ technology

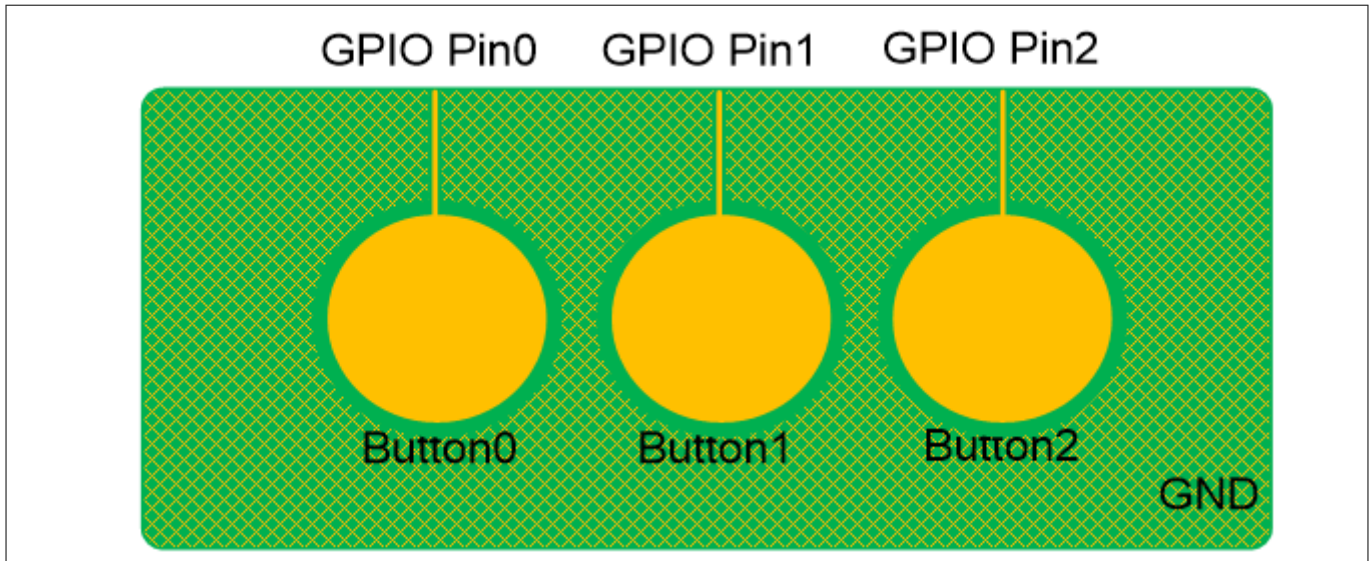

Figure 13 Simple CAPSENSE™ buttons

For the mutual-capacitance (CSX) sensing method, each button requires one GPIO pin configured as Tx electrode and one GPIO pin configured as Rx electrode. The Tx pin and Rx pins can be shared across multiple buttons, with each button being a unique intersection of Rx and Tx like in Figure 14. However, it is recommended to minimize the Rx trace length and shield the Rx trace with ground on both sides, to minimize noise coupling into the Rx.

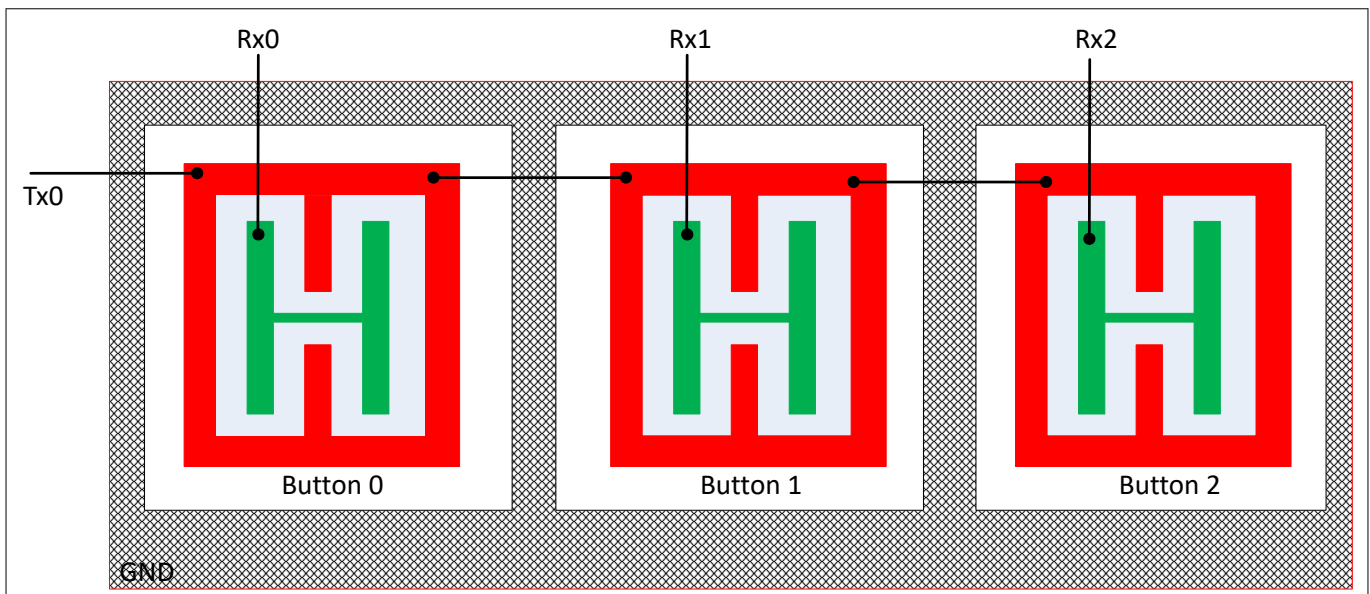

Figure 14 Simple CAPSENSE™ buttons for mutual-capacitance sensing method

If the application requires many buttons (for example in a calculator keypad or a QWERTY keyboard), you can arrange the CAPSENSE™ buttons in a matrix, as Figure 15 shows. This allows a design to have multiple buttons per GPIO. For example, the 16-button design in Figure 15 requires only eight GPIOs.

2 CAPSENSE™ technology

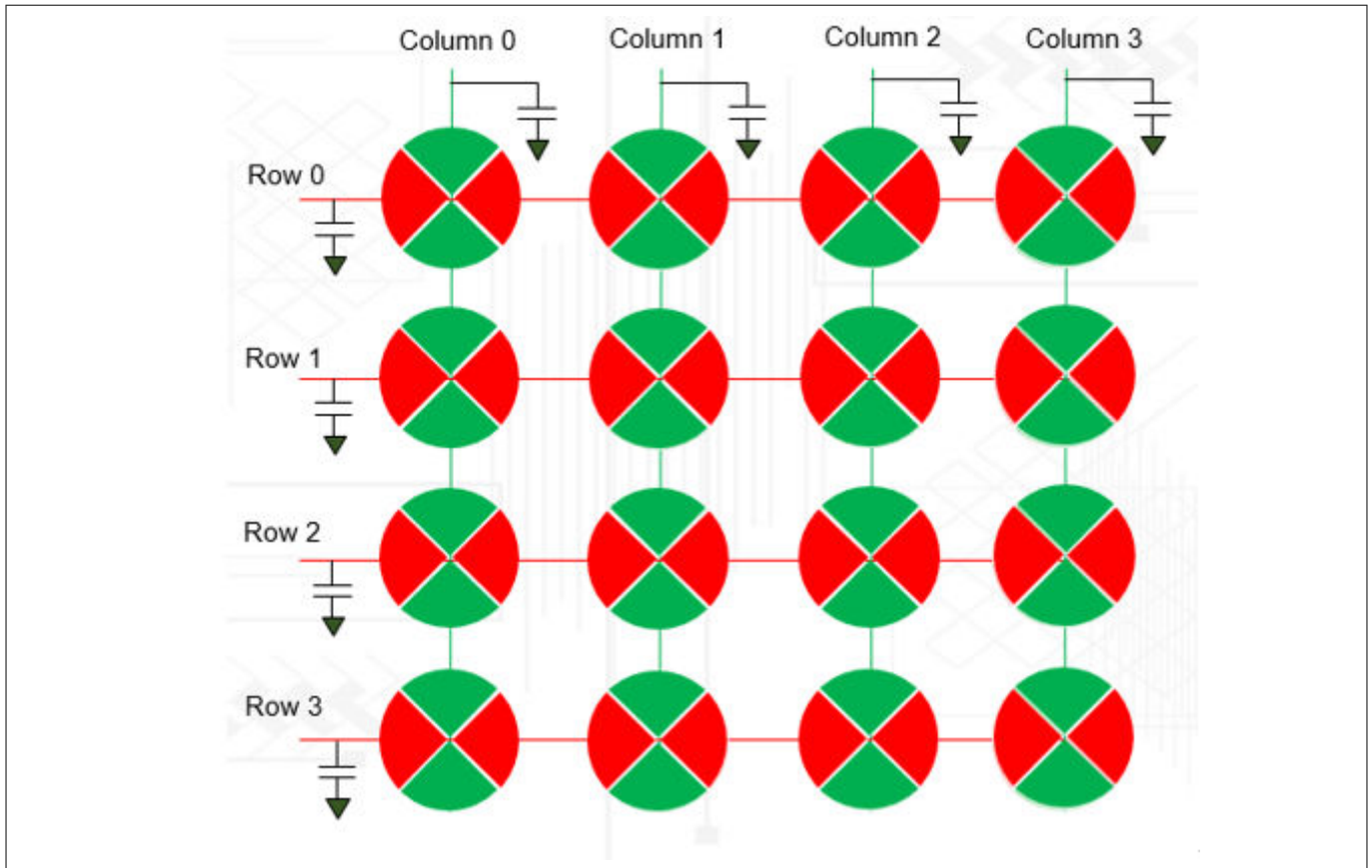

Figure 15 Matrix buttons based on CSD

A matrix button design has two groups of capacitive sensors: row sensors and column sensors. The matrix button architecture can be used for both self-capacitance (CSD) and mutual-capacitance (CSX) methods. In CSD mode, each button consists of a row sensor and a column sensor, as [Figure 15](#) shows. When a button is touched, both row and column sensors of that button become active. The CSD-based matrix button should be used only if the user is expected to touch one button at a time. If the user touches more than one diagonally opposite buttons, the finger location cannot be resolved as [Figure 16](#) shows. This effect is called as ghost effect, which is considered an invalid condition.

2 CAPSENSE™ technology

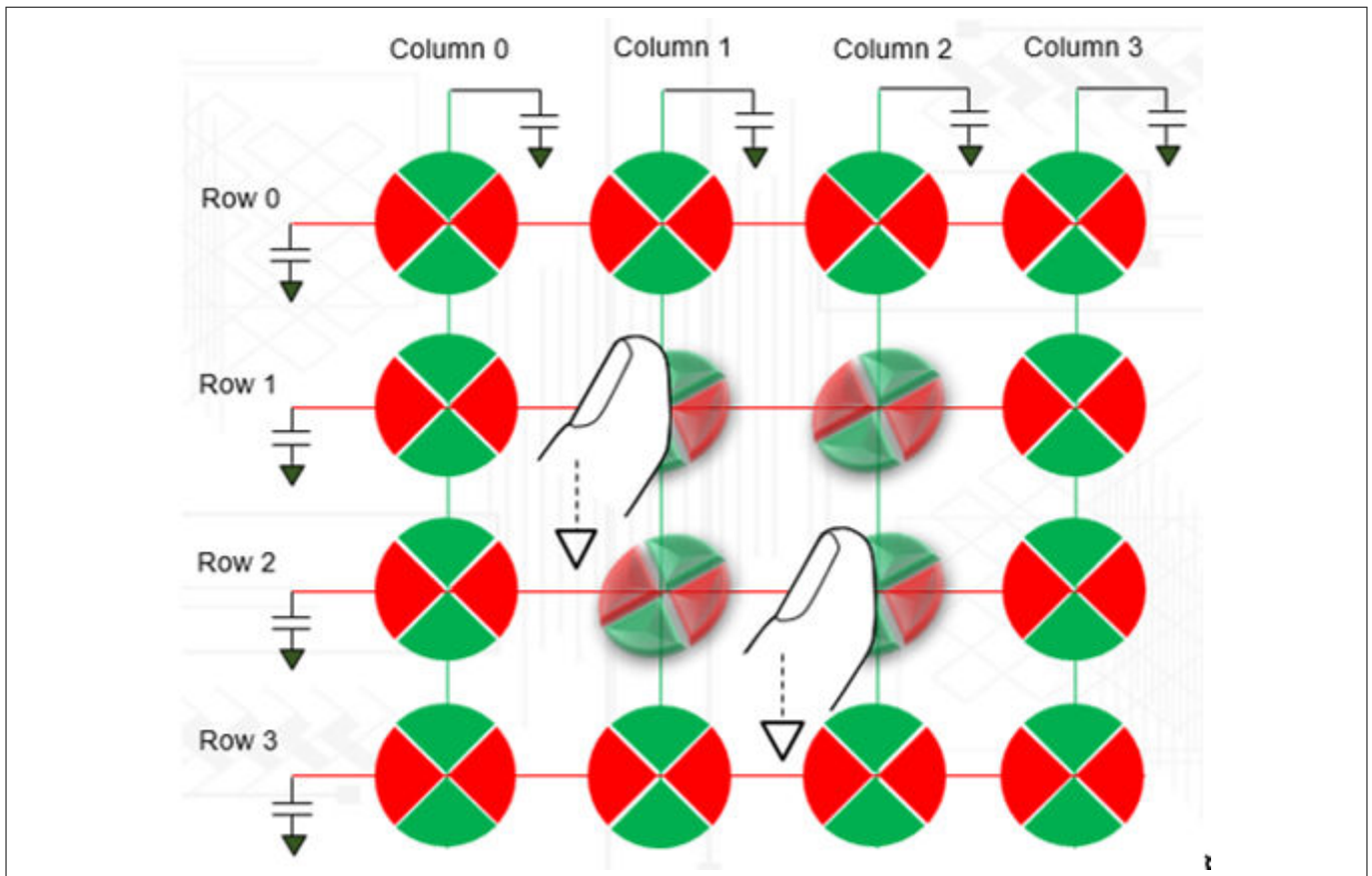

Figure 16 Ghost effect in matrix button based on CSD

Mutual-capacitance is the recommended sensing method for matrix buttons because this method is not affected from the ghost touch phenomena and provides better SNR for high C_p sensors. This is because it senses mutual-capacitance formed at each intersection rather than sensing rows and columns as shown in [Figure 17](#). Applications that require simultaneous sensing of multiple buttons, such as a keyboard with **Shift**, **Ctrl**, and **Alt** keys can use CSX sensing method or you should design the **Shift**, **Ctrl**, and **Alt** keys as individual CSD buttons.

2 CAPSENSE™ technology

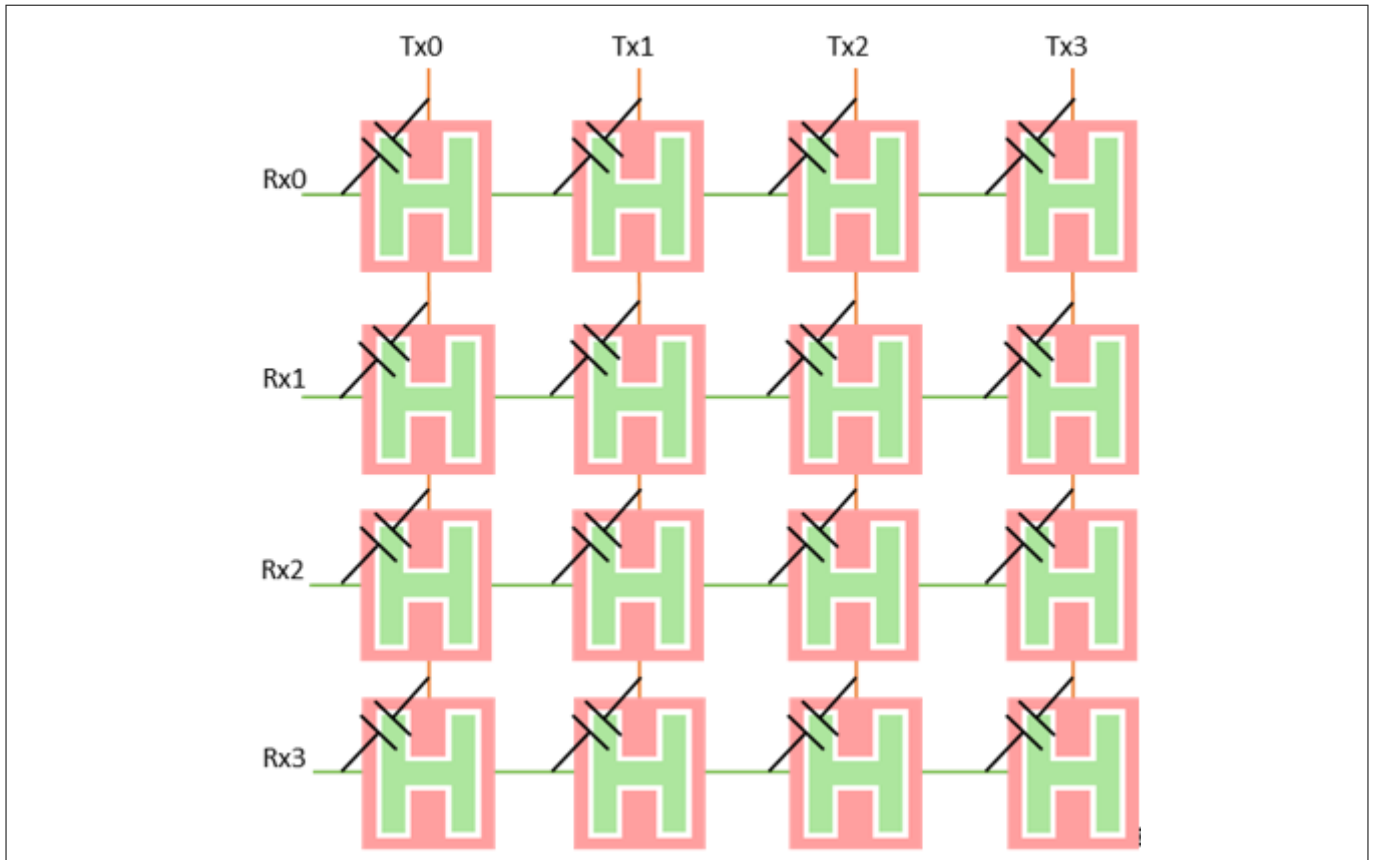

Figure 17 Matrix button based on CSX

Note: Scanning a matrix keypad using CSX sensing method may require a longer overall scan time than the CSD sensing method. This is because the CSD sensing method scans rows and columns as sensors, while the CSX sensing method scans each intersection as a sensor.

2.4.2 Sliders (one-dimensional)

Sliders are used when the required input is in the form of a gradual increment or decrement. Examples include lighting control (dimmer), volume control, graphic equalizer, and speed control. Currently, the CAPSENSE™ Component in PSoC™ Creator and ModusToolbox™ supports only self-capacitance-based sliders. Mutual capacitance-based sliders will be supported in future version of component.

A slider consists of a one-dimensional array of capacitive sensors called segments, which are placed adjacent to one another. Touching one segment also results in partial activation of adjacent segments. The firmware processes the raw counts from the touched segment and the nearby segments to calculate the position of the geometric center of the finger touch, which is known as the **centroid position**.

The actual resolution of the calculated centroid position is much higher than the number of segments in a slider. For example, a slider with five segments can resolve at least 100 physical finger positions. This high resolution gives smooth transitions of the centroid position as the finger glides across a slider.

In a linear slider, the segments are arranged inline, as [Figure 18](#) shows. Each slider segment connects to a PSoC™ GPIO. A zigzag pattern (double chevron) is recommended for slider segments. This layout ensures that when a segment is touched, the adjacent segments are also partially touched, which aids estimation of the centroid position.

2 CAPSENSE™ technology

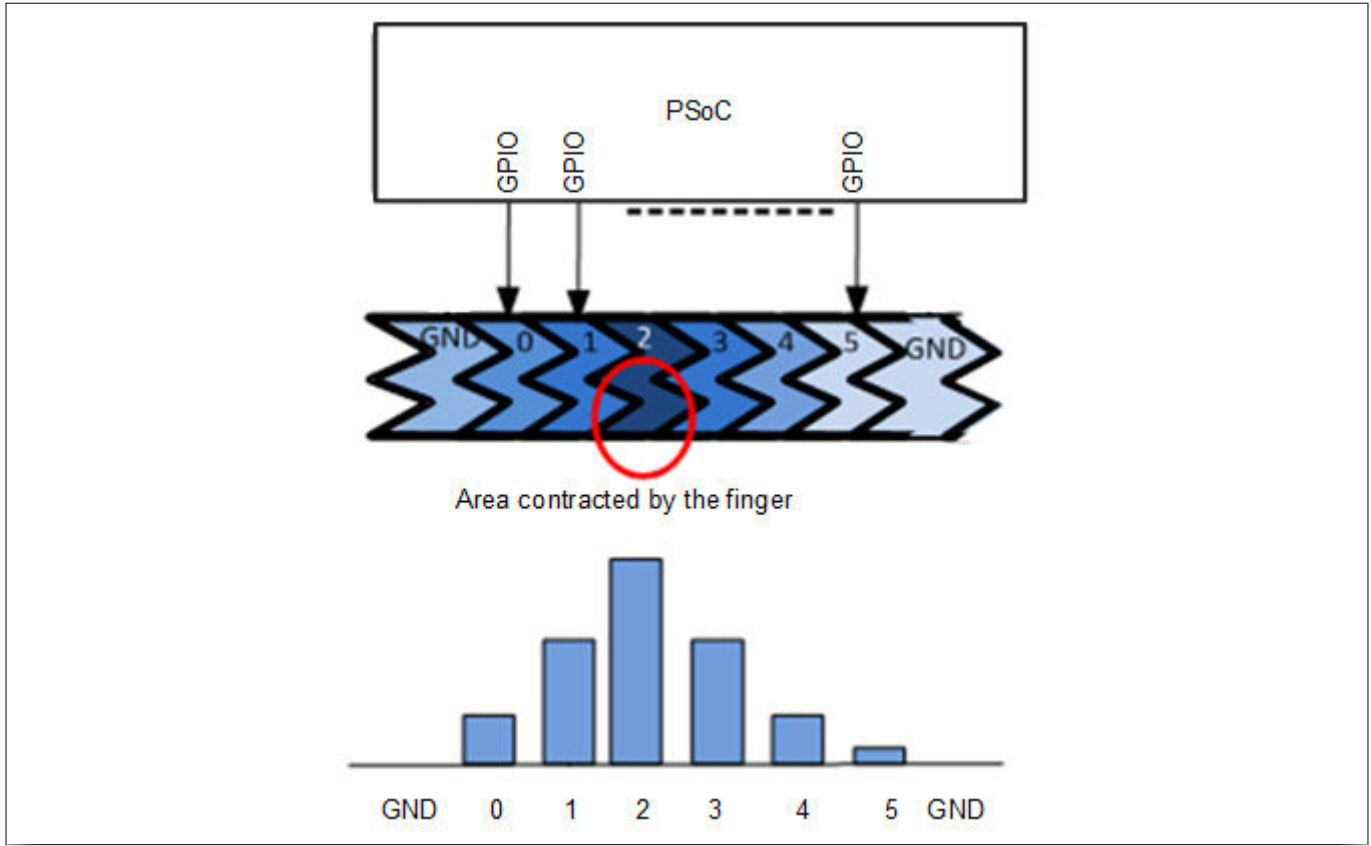

Figure 18 Linear slider

Radial sliders are similar to linear sliders except that radial sliders are continuous. [Figure 19](#) shows a typical radial slider.

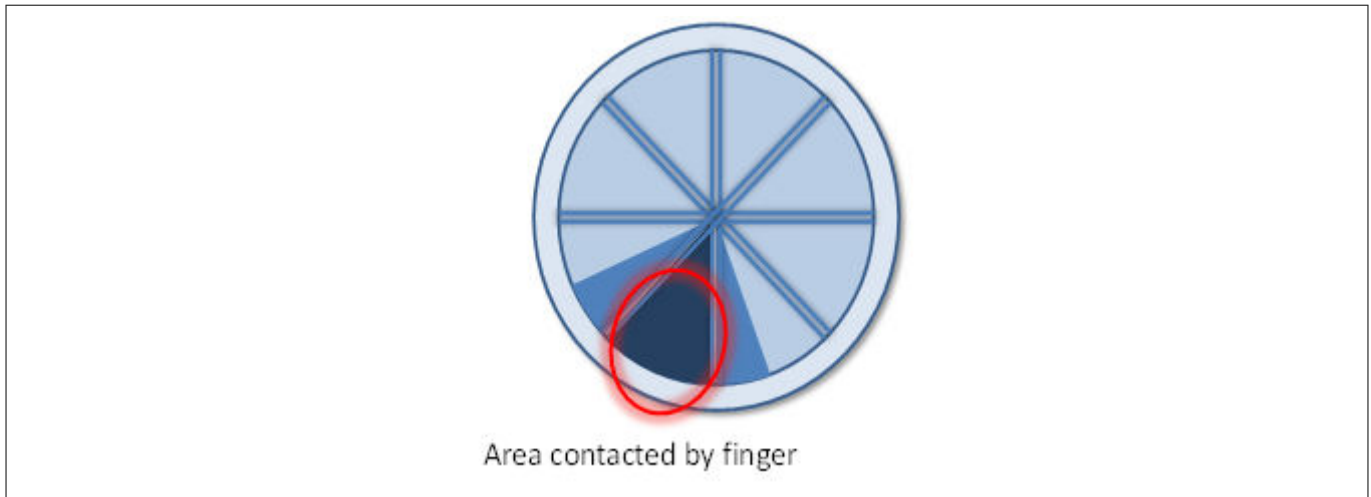

Figure 19 Radial slider

2.4.3 Touchpads/Trackpads (two-dimensional)

A touchpad (also known as trackpad) has two linear sliders arranged in an X and Y pattern, enabling it to locate a finger’s position in both X and Y dimensions. [Figure 20](#) shows a typical arrangement of a touchpad sensor. Similar to the matrix buttons, touchpads can also be sensed using either CSD or CSX sensing method. CSD-based touchpads suffer from ghost touches, so it supports only single-point touch applications.

2 CAPSENSE™ technology

CSX touchpads can support multi-point touch applications, but these may need more scanning time compared to CSD touchpad because this method scans each intersection rather than rows and columns.

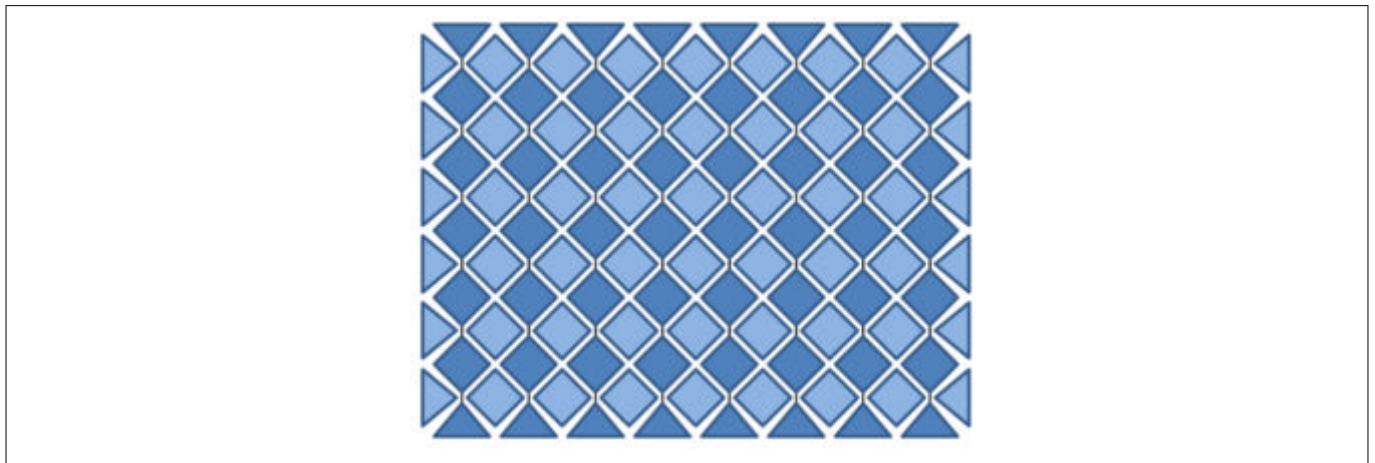

Figure 20 Touchpad sensor arrangement

See [AN234185 PSoC™ 4 CAPSENSE™ Touchpad design guide](#) to learn more.

2.4.4 Proximity (three-dimensional)

Proximity sensors detect the presence of a hand in the three-dimensional space around the sensor. However, the actual output of the proximity sensor is an ON/OFF state similar to a CAPSENSE™ button. Proximity sensing can detect a hand at a distance of several centimeters to tens of centimeters depending on the sensor construction. Self capacitance is the recommended method of sensing for a proximity application.

Proximity sensing requires electric fields that are projected to much larger distances than buttons and sliders. This demands a large sensor area. However, a large sensor area also results in a large parasitic capacitance C_p , and detection becomes more difficult. This requires a sensor with high electric field strength at large distances while also having a small area. [Figure 21](#) shows a proximity sensor using a trace with a thickness of 2-3 mm surrounding the other sensors.

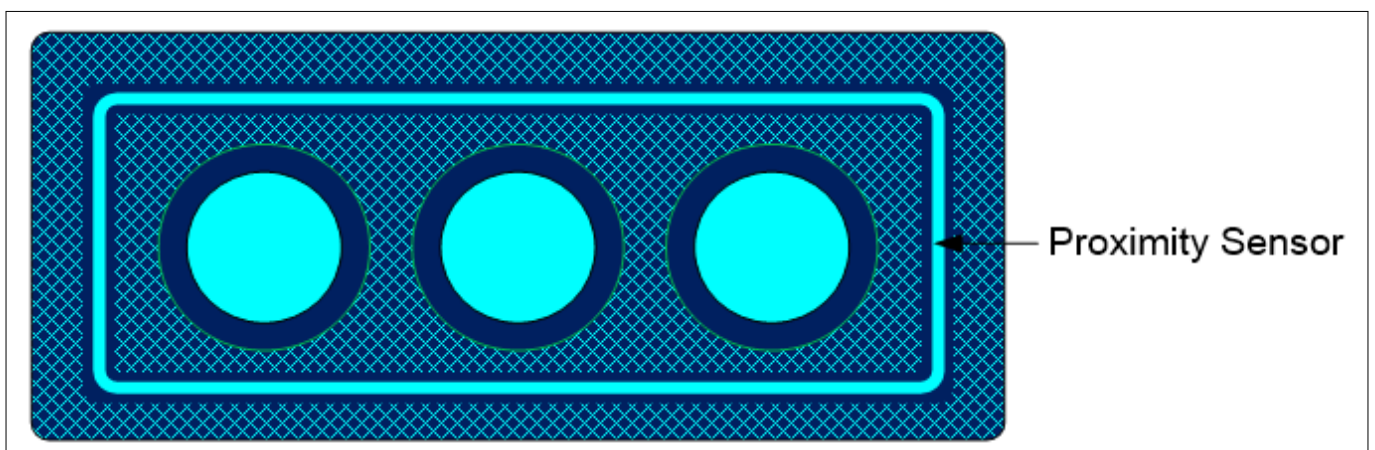

Figure 21 Proximity sensor

You can also implement a proximity sensor by ganging other sensors together. This is accomplished by combining multiple sensor pads into one large sensor using firmware. The disadvantage of this method is high parasitic capacitance. See the [Component datasheet/middleware document](#) for details on maximum parasitic capacitance supported by a given device.

See [AN92239 proximity sensing with CAPSENSE™](#) and the proximity sensing section in [Getting started with CAPSENSE™ design guide](#) to learn more about proximity sensors.

2 CAPSENSE™ technology

2.5 Liquid tolerance

Capacitive sensing is used in a variety of applications such as home appliances, automotive, and industrial applications. These applications require robust capacitive-sensing operation even in the presence of mist, moisture, water, ice, humidity, or other liquids. In a capacitive-sensing application design, false sensing of touch or proximity detection may happen due to the presence of a film of liquid or liquid droplets on the sensor surface, due to the conductive nature of some liquids. CSD sensing method can compensate for variation in raw count due to these causes and provide a robust, reliable, capacitive sensing application operation.



Figure 22 Liquid-tolerant CAPSENSE™-based touch user interface in washing machine

- To compensate for changes in raw count due to mist, moisture, and humidity changes, the CAPSENSE™ sensing method continuously adjusts the baseline of the sensor to prevent false triggers
- To prevent sensor false triggers due to a liquid flow, you should implement a [Guard sensor](#) as [Figure 23](#) shows. The [Driven shield signal and shield electrode](#) can be used to detect the presence of a streaming liquid and ignore the status or stop the sensing from rest of the sensors as long as the liquid flow is present
- *Note: the guard sensor itself is just another self-capacitance sensor; even though you could implement it around mutual-capacitance sensors also for liquid flow tolerance. PSoC™ devices allow implementation of such self-capacitance sensors and mutual-capacitance sensors together in the same design*
- To compensate for changes in raw count due to liquid droplets for self-capacitance sensing, you can implement a [Driven shield signal and shield electrode](#) as [Figure 23](#) shows. When a shield electrode is implemented, CAPSENSE™ reliably works and reports the sensor ON/OFF status correctly, even when liquid droplets are present on the sensor surface. To prevent sensor false triggers due to liquid droplets for mutual-capacitance sensing, you can use both the sensing methods that is, mutual capacitance and self-capacitance with [Driven shield signal and shield electrode](#) on the same set of sensors as [Using self-capacitance sensing for liquid tolerance of mutual-capacitance sensors](#) explains

In summary, if your application requires tolerance to liquid droplets, implement a [Driven shield signal and shield electrode](#). If your application requires tolerance to streaming liquids along with liquid droplets, implement a [Driven shield signal and shield electrode](#) and a [Guard sensor](#) as shown in [Figure 23](#). Follow the schematic and layout guidelines explained in the [Layout guidelines for liquid tolerance](#) section to construct the shield electrode and guard sensor respectively.

2 CAPSENSE™ technology

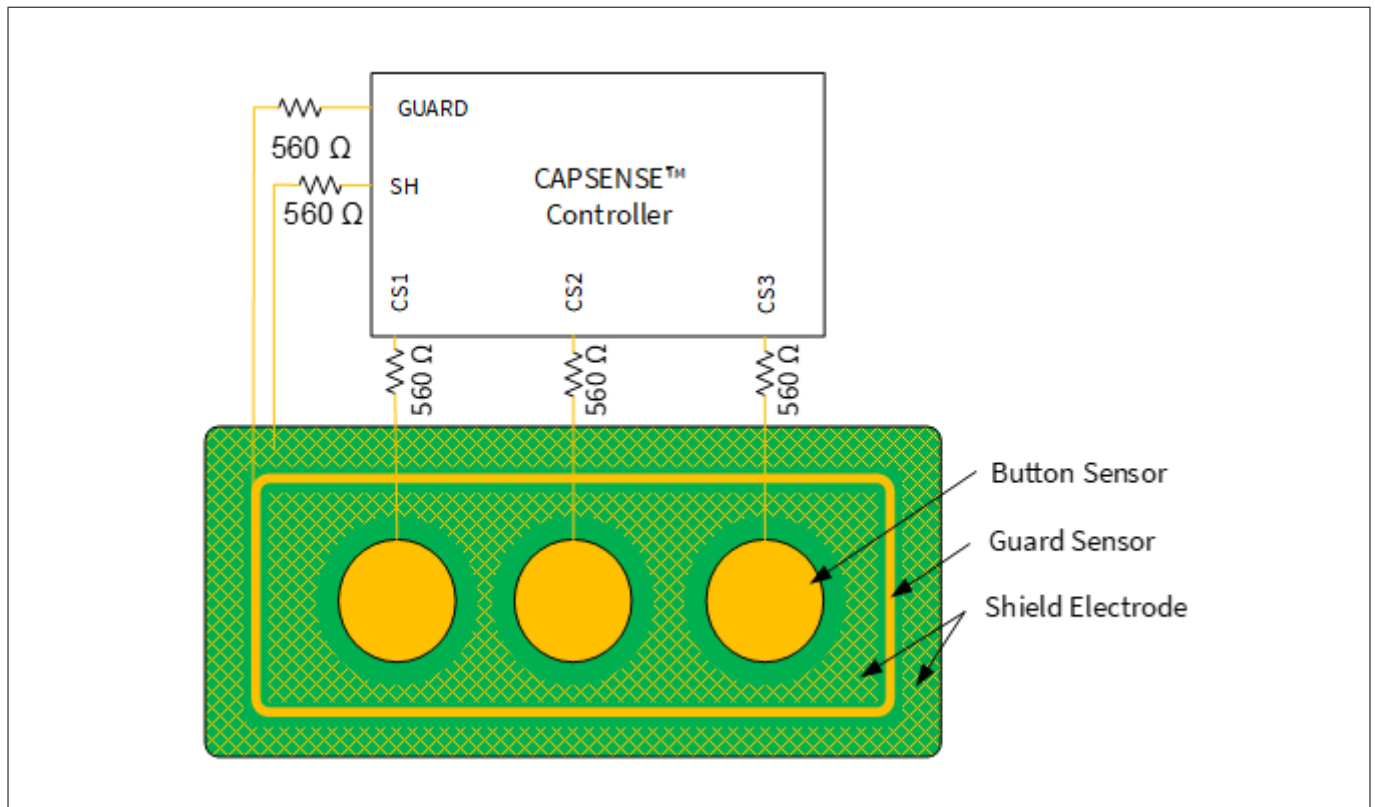

Figure 23 Shield electrode (SH) and guard sensor (GUARD) connected to CAPSENSE™ controller

2.5.1 Liquid tolerance for self capacitance sensing

2.5.1.1 Effect of liquid droplets and liquid stream on a self-capacitance sensor

To understand the effect of liquids on a CAPSENSE™ sensor, consider a CAPSENSE™ system in which the hatch fill around the sensor is connected to ground, as Figure 24(a) shows. The hatch fill when connected to a GND improves the noise immunity of the sensor. Parasitic capacitance of the sensor is denoted as C_p in Figure 24(b).

2 CAPSENSE™ technology

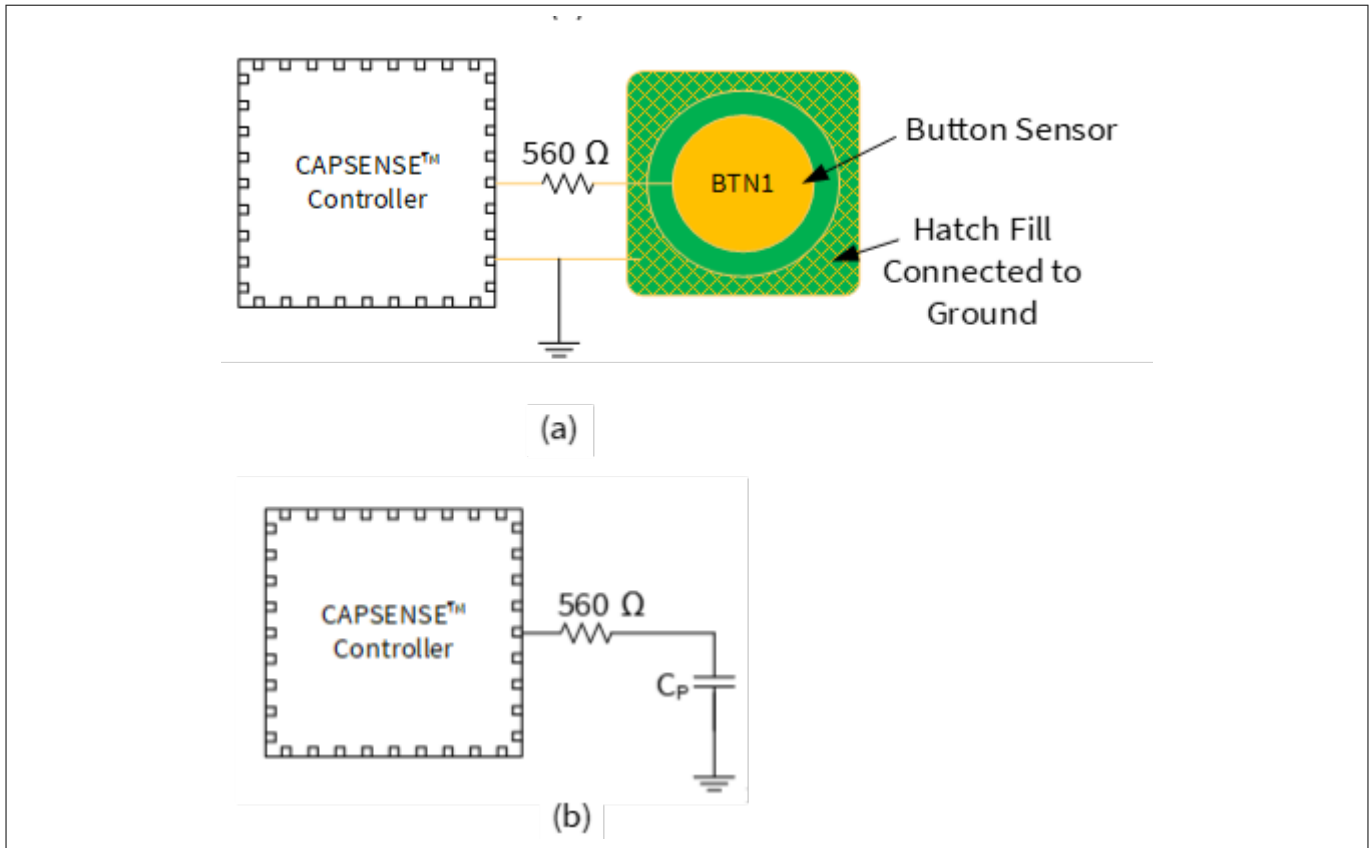

Figure 24 Typical CAPSENSE™ system layout

As shown in [Figure 25](#), when a liquid droplet falls on the sensor surface, due to its conductive nature it provides a strong coupling path for the electric field lines to return to ground; this adds a capacitance C_{LD} in parallel to C_P . This added capacitance draws an additional charge from the AMUX bus as explained in [GPIO cell capacitance to current converter](#) resulting in an increase in the sensor raw count. In some cases (such as salty water or water containing minerals), the increase in raw count when a liquid droplet falls on the sensor surface may be equal to the increase in raw count due to a finger touch, as [Figure 25](#) shows. In such a situation, sensor false triggers might occur.

2 CAPSENSE™ technology

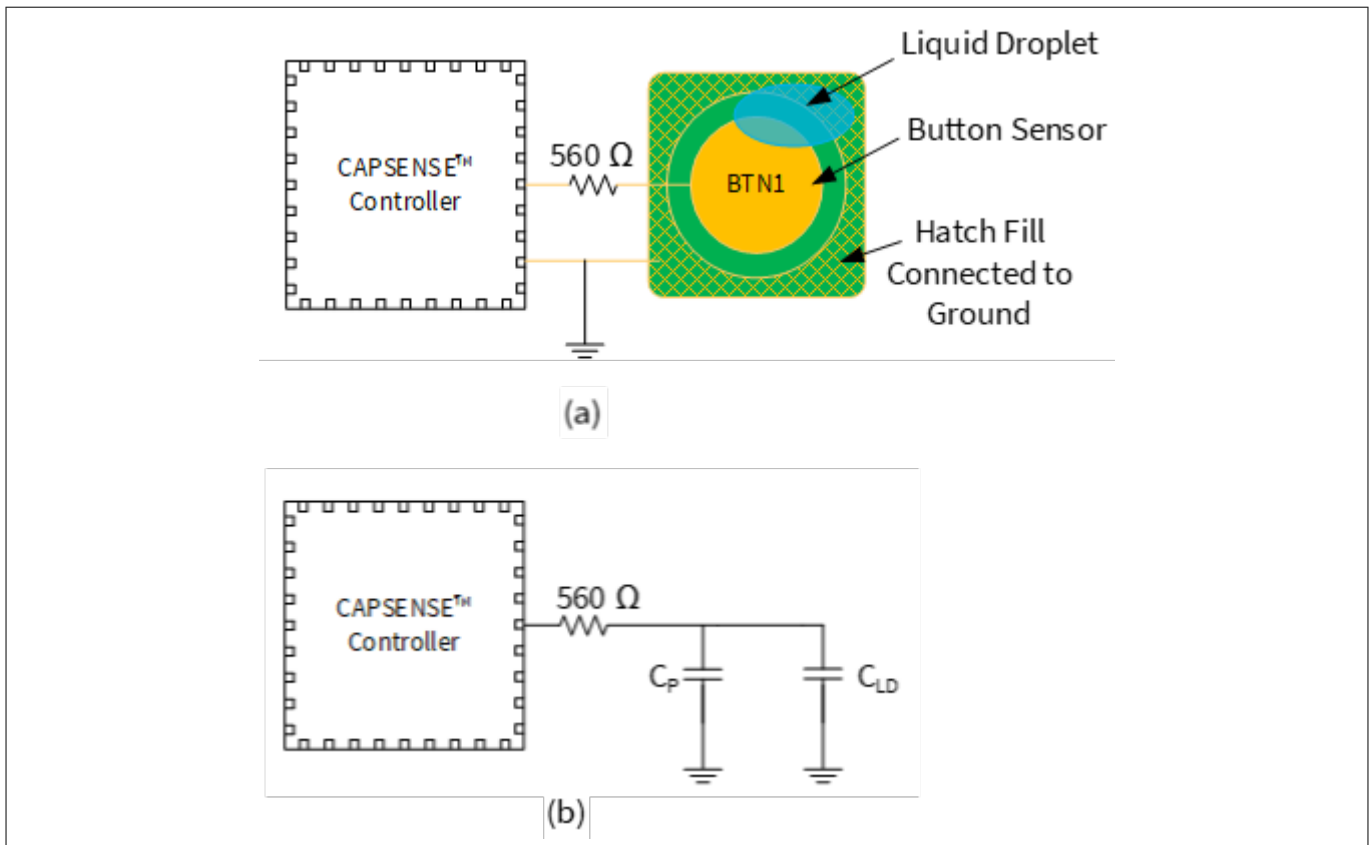

Figure 25 Capacitance added by liquid droplet when the Hatch Fill is connected to GND

C_p = Sensor parasitic capacitance

C_{LD} = Capacitance added by the liquid droplet

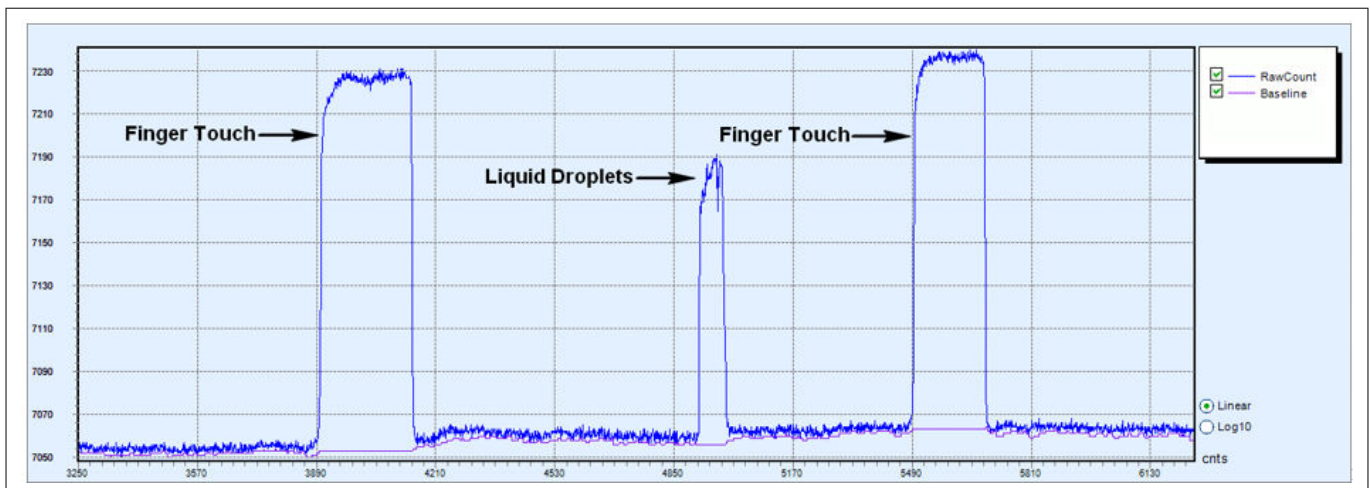

Figure 26 Effect of liquid droplet when the Hatch Fill around the sensor is connected to GND

To nullify the effect of capacitance added by the liquid droplet to the CAPSENSE™ circuitry, you should drive the hatch fill around the sensor with the [driven-shield signal](#).

As [Figure 27](#) shows, when the hatch fill around the sensor is connected to the driven-shield signal and when a liquid droplet falls on the touch interface, the voltage on both sides of the liquid droplet remains at the same potential. Because of this, the capacitance, C_{LD} , added by the liquid droplet does not draw any additional charge from the AMUX bus and hence the effect of capacitance C_{LD} is nullified. Therefore, the increase in raw count when a water droplet falls on the sensor will be very small, as [Figure 28](#) shows.

2 CAPSENSE™ technology

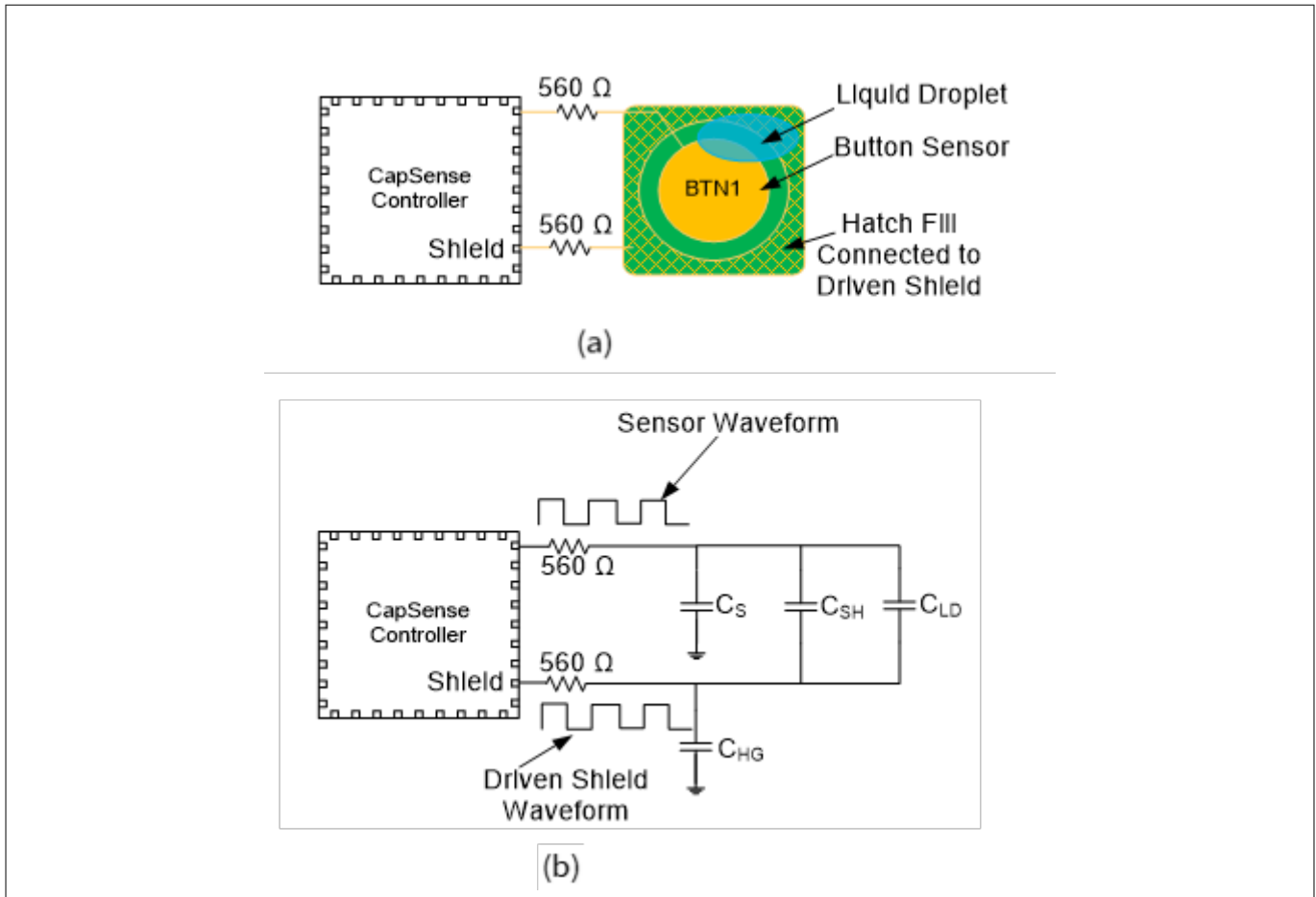

Figure 27 Capacitance added by liquid droplet when the hatch fill around the sensor is connected to shield

- C_S = Sensor parasitic capacitance
- C_{SH} = Capacitance between the sensor and the hatch fill
- C_{HG} = Capacitance between the hatch fill and ground
- C_{LD} = Capacitance added by the liquid droplet

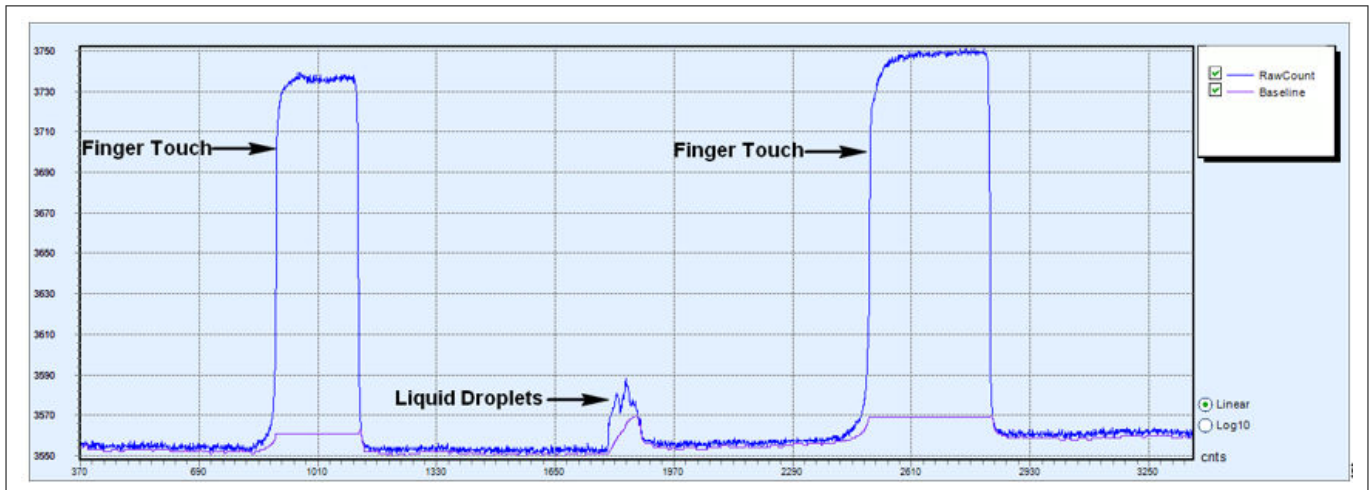

Figure 28 Effect of liquid droplet when the hatch fill around the sensor is connected to the driven-shield

2 CAPSENSE™ technology

Figure 26 shows how a sensor may false trigger in presence of a liquid, if hatch fill is connected to ground. Note however, that the same is not true for all cases. For example, **spring sensors**, which are inherently more liquid tolerant than sensors etched on PCB surface. As Figure 29 shows, due to the large airgap between the liquid drop and the hatch fill, the capacitance C_{LD} between the liquid drop and grounded hatch pattern on the PCB would be very low so as not to cause any false triggers. If required, the hatched pattern on the PCB can still be connected to a driven shield electrode to further nullify the effect of C_{LD} and have an improved liquid tolerance.

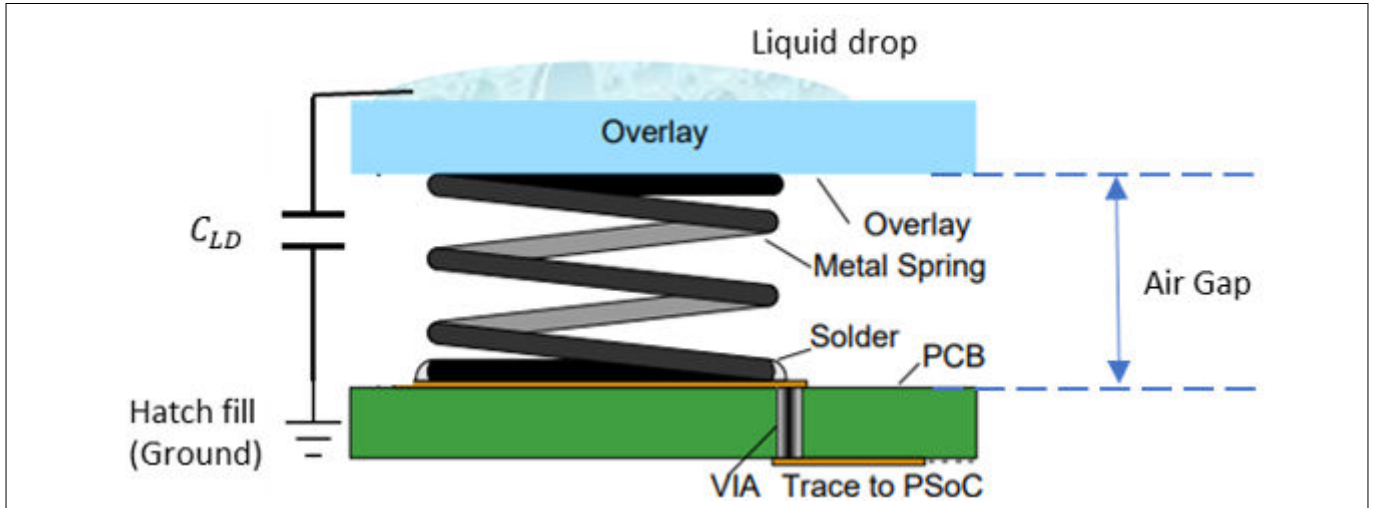

Figure 29 Capacitance added by liquid droplet in spring sensor

2.5.1.2 Driven shield signal and shield electrode

The driven-shield signal is a buffered version of the sensor-switching signal, as Figure 30 shows. The driven-shield signal has the same amplitude, frequency, and phase as that of sensor switching signal. When the hatch fill around the sensor is connected to the driven shield signal, it is referred as shield electrode.

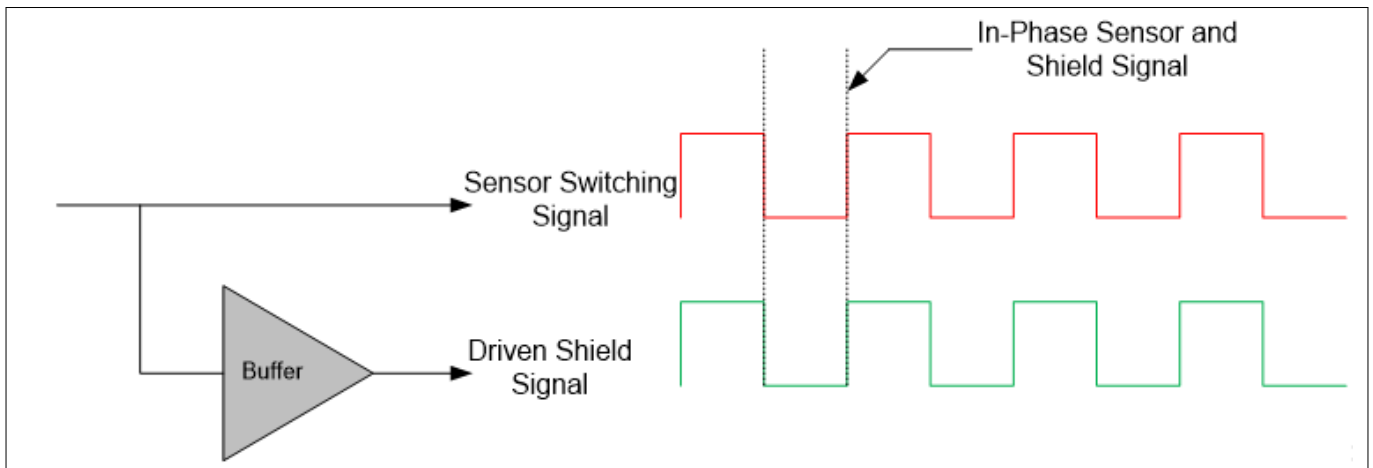

Figure 30 Driven shield signal

- To implement liquid-tolerant CAPSENSE™ designs: Shield electrode helps in making CAPSENSE™ designs liquid-tolerant as explained above
- To improve proximity sensing distance in presence of floating or grounded conductive objects: A shield electrode, when placed between the proximity sensor and a floating or a grounded conductive object, reduces the effect of these objects on the proximity-sensing distance and helps in achieving large

2 CAPSENSE™ technology

proximity-sensing distance. See the “Proximity Sensing” section in the [Getting started with CAPSENSE™ design guide](#) for more details

- To reduce the parasitic capacitance of the sensor: When a CAPSENSE™ sensor has a long trace, the CP of the sensor will be very high because of the increased coupling of sensor electric field lines from the sensor trace to the surrounding ground. By implementing a shield electrode, the coupling of electric field lines to ground is reduced, which results in reducing the CP of the sensor

See [Layout guidelines for shield electrode](#) for layout guidelines of shield electrode.

2.5.1.3 Guard sensor

When a continuous liquid stream is present on the sensor surface, the liquid stream adds a large capacitance (C_{ST}) to the CAPSENSE™ sensor. This capacitance may be several times larger than C_{LD} . Because of this, the effect of the shield electrode is completely masked, and the sensor raw counts will be same as or even higher than a finger touch. In such situations, a guard sensor is useful to prevent sensor false triggers.

A guard sensor is a copper trace that surrounds all the sensors on the PCB, as [Figure 31](#) shows. A guard sensor is similar to a button sensor and is used to detect the presence of streaming liquids. When a guard sensor is triggered, the firmware should disable the scanning of all other sensors except the guard sensor to prevent sensor false triggers.

Note: The sensors are not scanned, or the sensor status is ignored when the guard sensor is triggered; therefore, touch cannot be detected when there is a liquid stream on the touch surface.

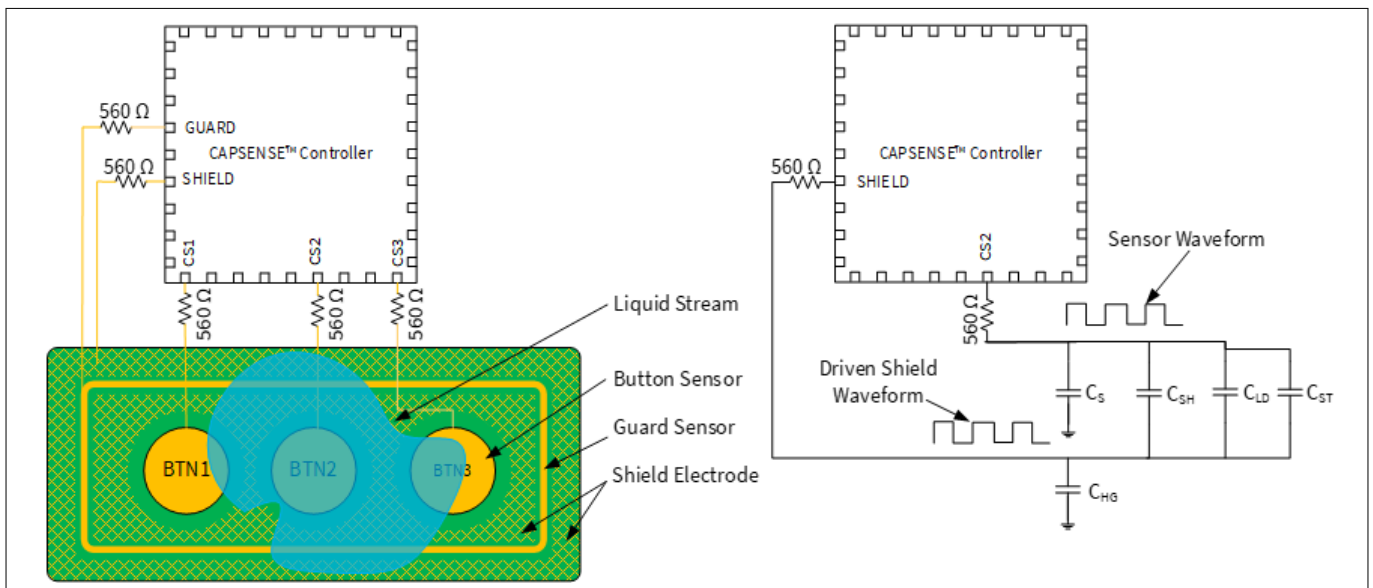

Figure 31 Measurement with a liquid stream

See [Layout guidelines for guard sensor](#) for PCB layout guidelines for implementing a guard sensor.

If there is no space on the PCB for implementing a guard sensor, the guard sensor functionality can be implemented in the firmware. For example, you can use the ON/OFF status of different sensors to detect a liquid stream depending on the use case, such as follows:

- When there is a liquid stream, more than one button sensor will be active at a time. If your design does not require multi-touch sensing, you can detect this and ignore the sensor status of all the button sensors to prevent false triggering

2 CAPSENSE™ technology

- In a slider, if the slider segments which are turned ON are not adjacent segments, you can reset the slider segments status or ignore the slider centroid value that is calculated
- Likewise, you could create your own custom algorithm to detect the presence of streaming liquids and ignore the sensor status during the time a liquid is present on the touch surface

Note: The sensors are not scanned, or the sensor status is ignored when the guard sensor is triggered; therefore, touch cannot be detected when there is a liquid stream on the touch surface

2.5.2 Liquid tolerance for mutual-capacitance sensing

2.5.2.1 Effect of liquid droplets and liquid stream on a mutual-capacitance sensor

Mutual-capacitance buttons often have a grounded hatch fill around the sensors for improved noise immunity. If a liquid droplet falls over the sensor while covering some part of the grounded hatch, the mutual-capacitance decreases similar to the effect of placing a finger on the sensor. This decrease in mutual-capacitance causes an increase in raw count as explained in CAPSENSE™ CSX sensing method (third- and fourth- generation) in and as shown in the Figure 32. The amount of increase in the raw count depends on the size and characteristics of the liquid drop.

However, mutual-capacitance increases if the liquid droplet covers just the Tx and Rx electrode and does not spread over the grounded hatch. This causes a decrease in raw count as shown in Figure 32. This decrease in raw count may cause the baseline reset due to Low baseline reset. Once the liquid drop is removed, the raw count would rise while the baseline may remain at the lower value, resulting in a difference signal which may cause the sensor to false trigger.

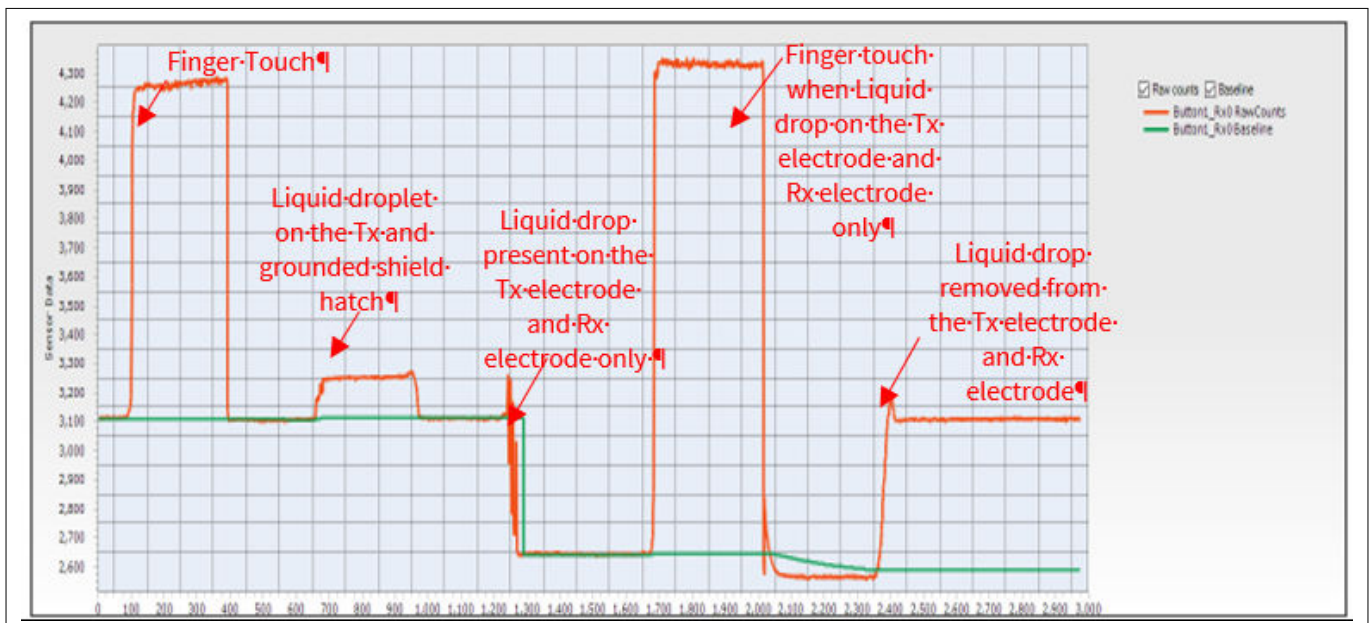

Figure 32 Effect of liquid droplet on CSX sensor when the Hatch Fill around the sensor is connected to ground

2 CAPSENSE™ technology

2.5.2.2 Using self-capacitance sensing for liquid tolerance of mutual-capacitance sensors

CAPSENSE™ senses the self-capacitance of Tx and Rx nodes of a mutual-capacitance sensor. This ability of scanning the sensor using both CSD and CSX modes could be used to avoid false triggers due to the presence of liquid drops on a mutual capacitance sensor. See the code example [PSoC™ 4 hybrid sensing using CAPSENSE™](#) to understand how to sense a mutual-capacitance button with both CSD as well as CSX sensing method.

To achieve liquid tolerance, you need to scan the Rx electrode of the sensor with the CSD sense method. While scanning the Rx electrode as a CSD sensor, ensure that you enable the shield electrode, and connect the Tx pin of the mutual-capacitance sensor to the driven shield signal. You can use the low-level API function `CapSense_SetPinState()` to connect the Tx pin of the mutual-capacitance sensor to the shield electrode before calling the `CapSense_ScanAllWidgets()` API function that scans the Rx electrode as a CSD sensor as shown below:

```
CapSense_SetPinState(CapSense_BUTTON1_WDGT_ID, CapSense_BUTTON1_TX0_ID, CapSense_SHIELD);
CapSense_ScanAllWidgets();
```

From sections 2.5.1 and 2.5.2 you understood the effect of liquid drop on the CSD and CSX button respectively. By utilizing the difference in their response to the liquid drop, you can create a firmware logic to achieve a liquid-tolerant mutual-capacitance sensor. The effect of presence of the liquid drop on the CSD and CSX scan results is summarized in [Figure 33](#).

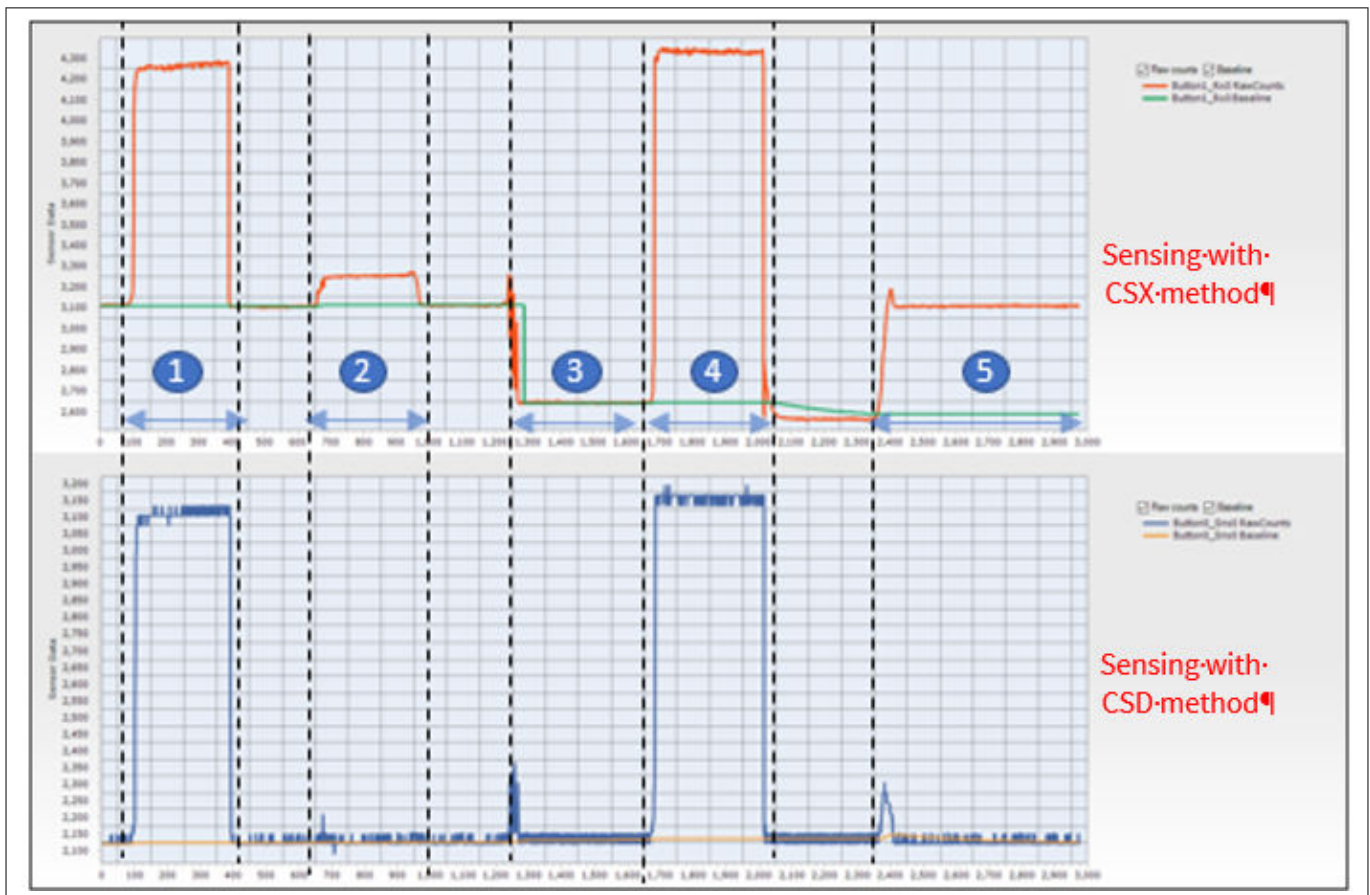

Figure 33 Effect of water drop on the CSX sensor pattern scanned with CSD and CSX methods

Where [Figure 33](#) shows the effect of the water drop on the CSX sensor pattern surrounded by hatch fill when scanned using this method. The regions in [Figure 33](#) represent the following:

2 CAPSENSE™ technology

1. Finger touch
2. Liquid droplet on the Tx line and grounded shield hatch
3. Liquid drop present on the Tx and Rx electrodes only
4. Finger touch when a liquid drop is on the Tx and Rx electrodes only
5. Liquid drop removed from the Tx and Rx electrodes

The changes in raw count as shown in [Figure 33](#) can be used in the firmware to reset the baseline of the CSX sensor to nullify the effect of liquid drops. The button status should be ON state for Region 1, 4, and OFF state in other regions; additionally, the baseline of the CSX button must be re-initialized in Region 3 and Region 5. The baseline of the sensor could be reset by using the `CapSense_InitializeWidgetBaseline()` API function as shown below:

```
CapSense_InitializeWidgetBaseline(CapSense_CSX_BUTTON_WDGT_ID);
```

See the [Component datasheet/middleware document](#) or more details on using this API; see [Selecting CAPSENSE™ software parameters](#) to learn about the baseline of the sensor.

2.5.3 Effect of liquid properties on liquid-tolerance performance

In certain applications, the CAPSENSE™ system has to work in the presence of a variety of liquids such as soap water, sea water, and mineral water. In such applications, it is always recommended to tune the CAPSENSE™ parameters for sensors by considering the worst-case signal due to liquid droplets. To simulate the worst-case conditions, it is recommended that you test the liquid-tolerance performance of the sensors with salty water by dissolving 40 grams of cooking salt (NaCl) in one liter of water. Tests were done using soapy water; the results show that the effect of soapy water is similar to the effect of salty water. Therefore, if the tuning is done to reject salty water, the CAPSENSE™ system will work even in the presence of soapy water.

In applications such as induction cooktops, there are chances of hot water spilling on to the CAPSENSE™ touch surface. To determine the impact of the temperature of a liquid droplet on CAPSENSE™ performance, droplets of water at different temperatures were poured on a sensor and the corresponding change in raw counts was monitored. Experiment shows that the effect of hot liquid droplets is same as that of the liquid at room temperature as [Figure 34](#) shows. This is because the hot liquid droplet cools down immediately to room temperature when it falls on the touch surface. If hot water continuously falls on the sensor and the temperature of the overlay rises because of the hot water, the increase in raw count due to the increase in temperature is compensated by the [Baseline update algorithm](#), thereby preventing any false triggering of the sensors.

2 CAPSENSE™ technology

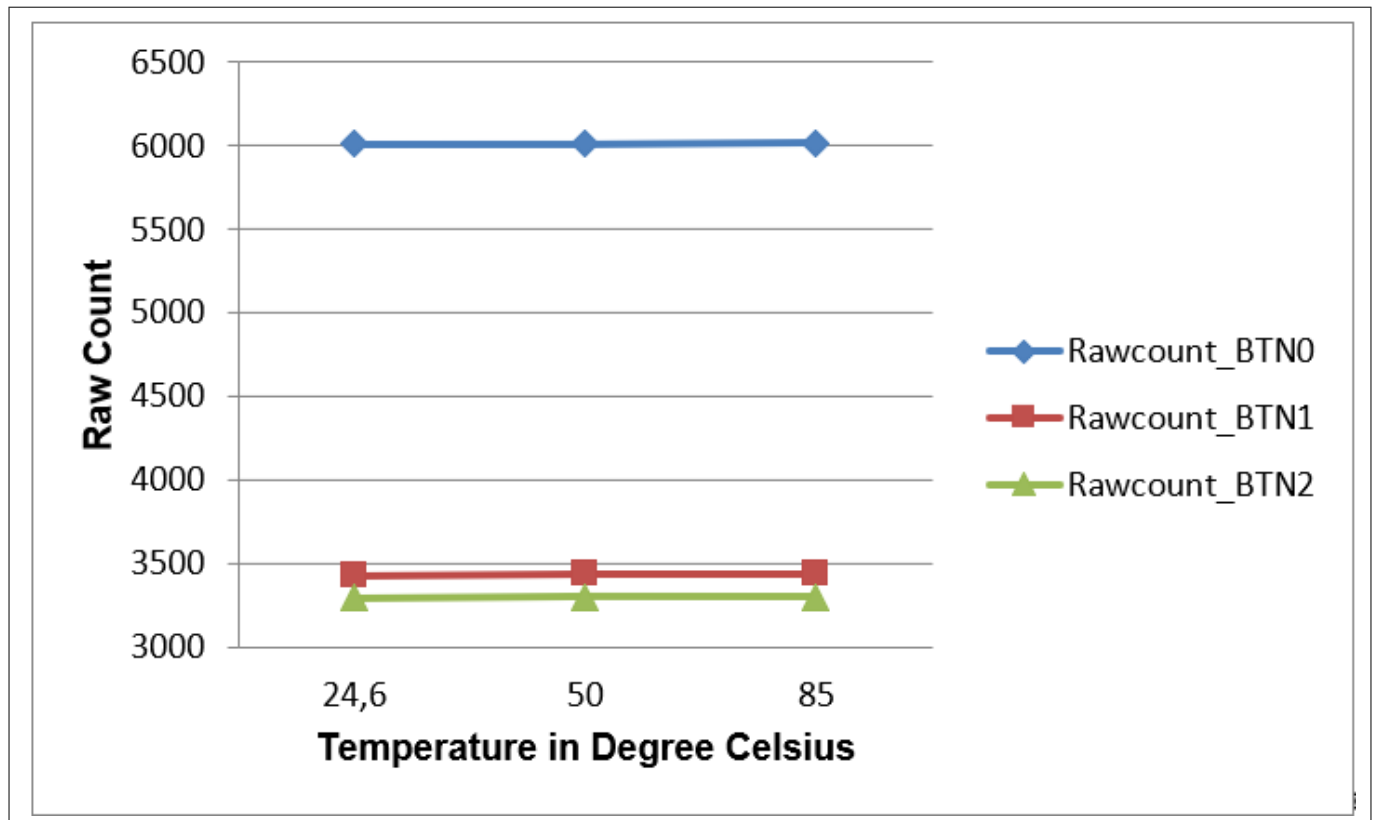

Figure 34 Raw count variation versus water temperature

3 PSoC™ 4 and PSoC™ 6 MCU CAPSENSE™

3 PSoC™ 4 and PSoC™ 6 MCU CAPSENSE™

This chapter explains how CAPSENSE™ CSD and CSX (third, fourth, and fifth generations) are implemented in the PSoC™ 4 and PSoC™ 6 MCUs. See [Capacitive touch sensing method](#) to understand the basic principles of CAPSENSE™. A basic knowledge of the PSoC™ device architecture is a prerequisite for this chapter. If you are new to PSoC™ 4, see [AN79953 - Getting started with PSoC™ 4](#) or [AN91267 - Getting started with PSoC™ 4 Bluetooth® LE](#); for PSoC™ 6 MCU, see [AN221774 - Getting started with PSoC™ 6 MCU](#).

You can skip this chapter if you are using the automatic tuning feature (SmartSense) of the Component. See the [CAPSENSE™ performance tuning](#) chapter for details.

The PSoC™ 4 family of devices has three different CAPSENSE™ architectures. [Table 2](#) explains the differences between the third and fifth-generation CAPSENSE™ architecture.

3.1 CAPSENSE™ generations in PSoC™ 4 and PSoC™ 6

[Table 2](#) lists the main differences in the CAPSENSE™ architecture for CSD and CSX.

Table 2 Comparison of CAPSENSE™ architecture for CSD and CSX

Feature	Third-generation CAPSENSE™	Fourth-generation CAPSENSE™	Fifth-generation CAPSENSE™	Improvement impact	Conditions
SNR	5:1	6.5:1	48:1	Higher SNR implies better sensitivity, that is, ability to sense smaller signals.	$V_{DD} = 5\text{ V}$; No firmware filter; $C_p \approx 33\text{ pF}$; $C_f = 0.1\text{ pF}$
Sensing mode	Self-cap and mutual-cap modes	Self-cap, mutual-cap, and ADC modes	Self-cap and mutual-cap modes	–	–
Sensor capacitance parasitic range	5 pF – 45 pF	5 pF – 200 pF	2 pF – 200 pF	Greater C_p range implies higher flexibility in PCB layout routing and ability to sense with very short/ long sensor traces, and for different PCB materials (for example, FFC and so on).	–

(table continues...)

3 PSoC™ 4 and PSoC™ 6 MCU CAPSENSE™

Table 2 (continued) Comparison of CAPSENSE™ architecture for CSD and CSX

Feature	Third-generation CAPSENSE™	Fourth-generation CAPSENSE™	Fifth-generation CAPSENSE™	Improvement impact	Conditions
Typical sense signal needed	100 fF	100 fF	15 fF for CSD-RM 10 fF for CSX-RM	Smaller sense signal required, implying support for thicker overlays, higher proximity range, smaller sensor size, and so on.	$V_{DD} = 5\text{ V}$; No firmware filter; $C_p \sim 33\text{ pF}$; SNR = 5:1;
Noise floor (rms)	–	–	500 aF for CSD-RM 100 aF for CSX-RM	Higher SNR or lower noise floor implies ability to sense smaller signals.	$V_{DD} = 5\text{ V}$; $C_p \sim 33\text{ pF}$; $C_M = 5\text{ pF}$
Overlay thickness supported	Up to 5 mm	Up to 5 mm	Up to 18 mm	Supports designs with thicker overlay.	10 mm CSD button; Acrylic overlay; SNR = 5:1; $C_p \sim 22\text{ pF}$;
Refresh rate	–	22 Hz	242 Hz	Faster refresh rate enables fast gestures and taps detections on applications such as large trackpad and long sliders or large number of button sensors with single device, and so on.	7x5 CSX touchpad; Acrylic overlay 3 mm thickness; SNR = 10:1; Finger Size = 8 mm;
CPU bandwidth requirement	Completely CPU driven. CPU is required for initialization and sequencing the sensors.	40% sequencer ¹⁾ It takes care of initialization, configuration, and scanning of sensors. CPU is needed for sequencing through each sensor.	7% Completely autonomous.	Reduced CPU usage for sensing frees the CPU to perform other peripheral operations, and act as a central controller in an application.	10x8 CSX touchpad; Scan clock = 1 MHz; No of sub-conversions = 70; Refresh rate = 100 Hz;
Emission control options.	PRS	PRS, SSC	PRS, SSC	–	–

(table continues...)

3 PSoC™ 4 and PSoC™ 6 MCU CAPSENSE™

Table 2 (continued) Comparison of CAPSENSE™ architecture for CSD and CSX

Feature		Third-generation CAPSENSE™	Fourth-generation CAPSENSE™	Fifth-generation CAPSENSE™	Improvement impact	Conditions
Noise immunity	Sense Voltage (V_{ref})	1.2 V	1.2 V-2.8 V.	Rail to Rail	Higher the sense voltage, higher the noise immunity.	-
	Differential Sensing	Mutual-cap sensing	Mutual-cap sensing	Mutual-cap and self-cap sensing	Differential sensing cancels out noise induced from external environment through C_{MOD} .	
	V_{DD} noise impact	Yes	Yes	No	V_{DD} noise has minimal affect on fifth generation CAPSENSE™ operation.	
Sense clock frequency	Self-Cap	45 kHz – 6 MHz	45 kHz – 6 MHz	45 kHz – 6 MHz	Higher sense clock frequency means faster scan for low C_p sensors. This provides ability to support faster taps or gestures, or for a given refresh rate, ability to implement multiple firmware filters for better immunity.	-
	Mutual-Cap	45 kHz - 300 kHz	45 kHz - 3 MHz	45 kHz – 6 MHz		
Multi-channel support		No	No	Yes	Provides ‘n’ times increased speed of scanning for the same number of sensors, if ‘n’ channels are used.	-
Shield C_p		--	--	1.2 nF	-	-
Device family		PSoC™ 4100/4200 PSoC™ 4100 M/4200 M PSoC™ 4100 L/4200 L PSoC™ 4100 BL/4200 BL	PSoC™ 4000 PSoC™ 4000S PSoC™ 4100S PSoC™ 4100S Plus PSoC™ 6	PSoC™ 4100 S Max PSoC™ 4000 T (fifth-generation low-power)	-	-

3 PSoC™ 4 and PSoC™ 6 MCU CAPSENSE™

1) The hardware state machine is a logic which controls the CAPSENSE™ block and sensor scanning.

3.2 Capacitive Sigma-Delta (CSD) sensing method (third and fourth generation)

Figure 35 illustrates the CAPSENSE™ block that scans CAPSENSE™ sensors in the CSD sensing mode.

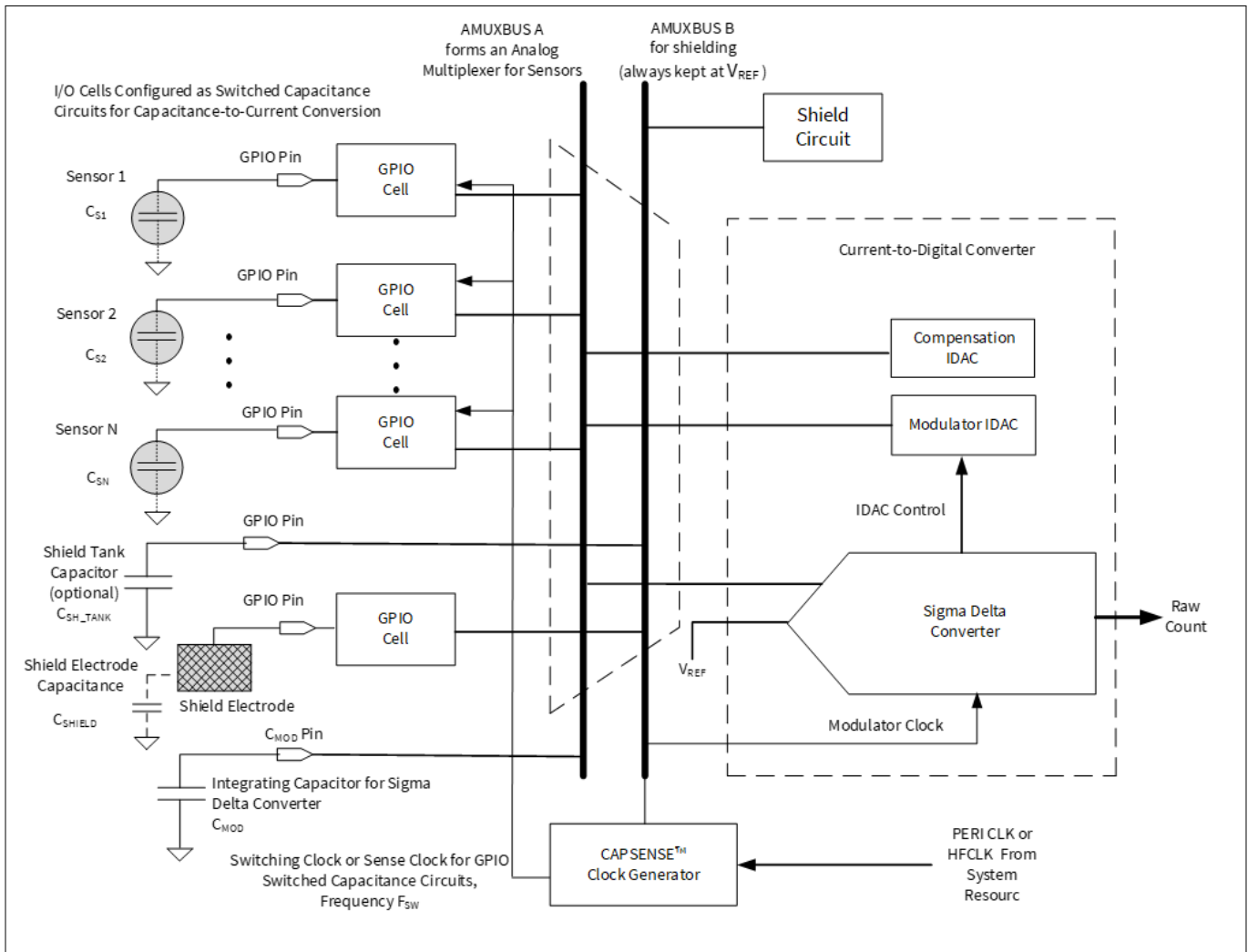

Figure 35 CAPSENSE™ CSD sensing

As explained in [Capacitive touch sensing method](#), this block works by first converting the sensor capacitance into an equivalent current. An analog multiplexer then selects one of the currents and feeds it into the current-to-digital converter. This current-to-digital converter consists of a sigma-delta converter, which controls the modulation IDAC for a specific period, the total current sourced or sinked by the IDACs is the same as the total current sinked or sourced by the sensor capacitance. The digital count output of the sigma-delta converter is an indicator of the sensor capacitance and is called a raw count. This block can be configured in either IDAC Sourcing mode or IDAC Sinking mode. In the IDAC Sourcing mode, the IDACs source current to AMUXBUS while the GPIO cells sink current from AMUXBUS. In the IDAC Sinking mode, the IDACs sink current from AMUXBUS while the GPIO cells source current to AMUXBUS.

3 PSoC™ 4 and PSoC™ 6 MCU CAPSENSE™

3.2.1 GPIO cell capacitance to current converter

In the CAPSENSE™ CSD system, the GPIO cells are configured as switched-capacitance circuits that convert sensor capacitances into equivalent currents. Figure 36 shows a simplified diagram of the GPIO cell structure.

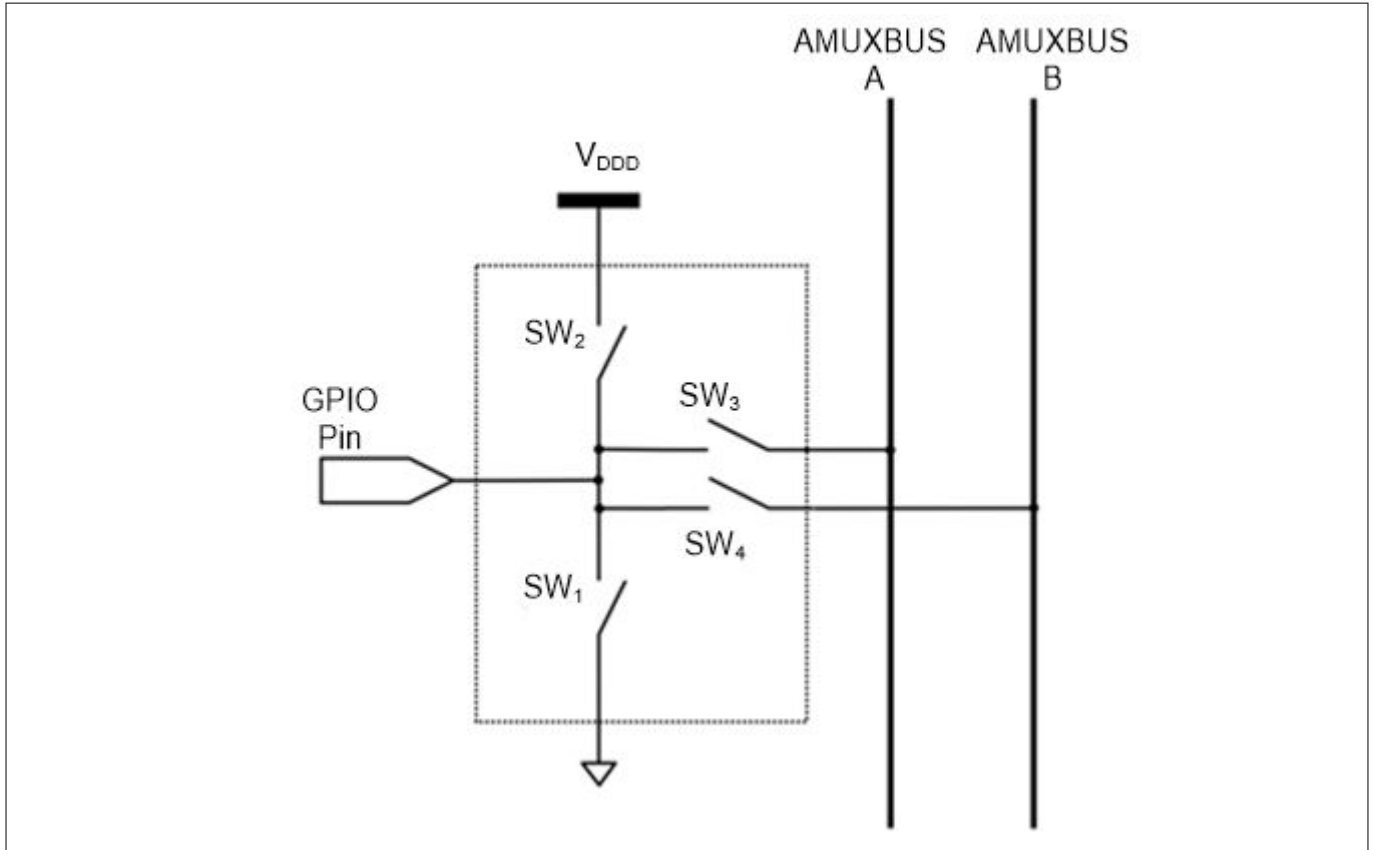

Figure 36 GPIO cell structure

PSoC™ 4 and PSoC™ 6 devices consist of two AMUX buses: AMUXBUS A is used for CSD sensing and AMUXBUS B is used for CAPSENSE™ CSD shielding. The GPIO switched-capacitance circuit has two possible configurations: source current to AMUXBUS A or sink current from AMUXBUS A

3.2.2 IDAC sourcing mode

In the IDAC Sourcing mode, the GPIO cell sinks current from the AMUXBUS A through a switched capacitor circuit as Figure 37 shows.

3 PSoC™ 4 and PSoC™ 6 MCU CAPSENSE™

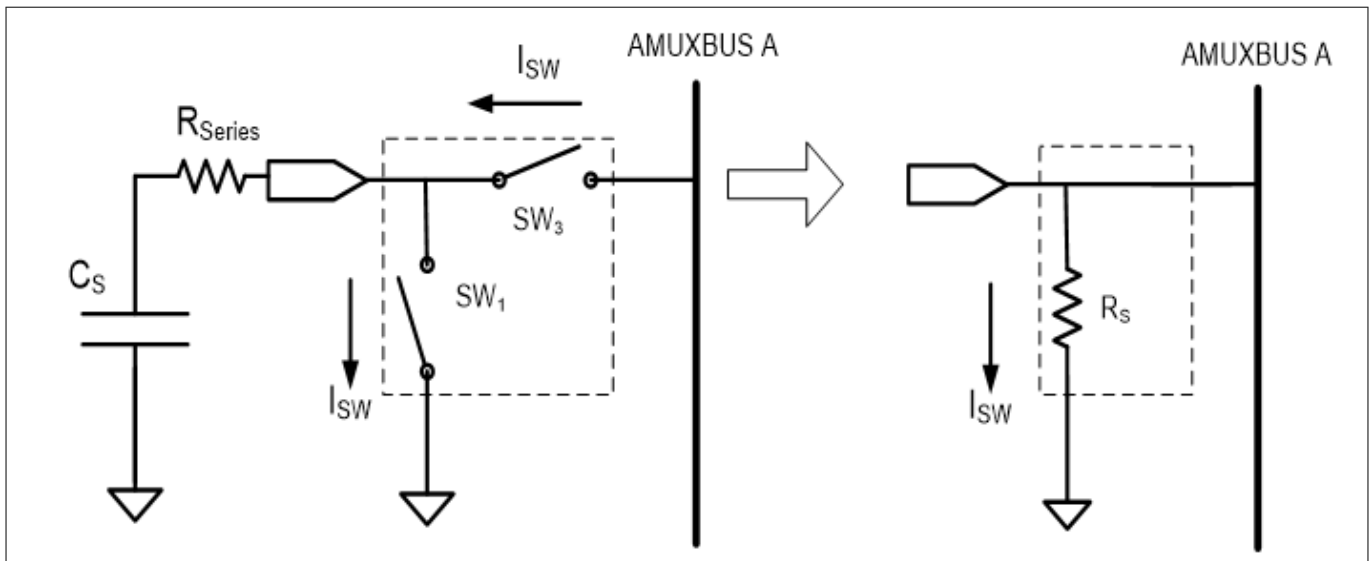

Figure 37 GPIO cell sinking current from AMUXBUS A

Two non-overlapping, out-of-phase clocks of frequency F_{SW} control the switches SW_1 and SW_3 as Figure 38 shows. The continuous switching of SW_1 and SW_3 forms an equivalent resistance R_S , as Figure 37 shows.

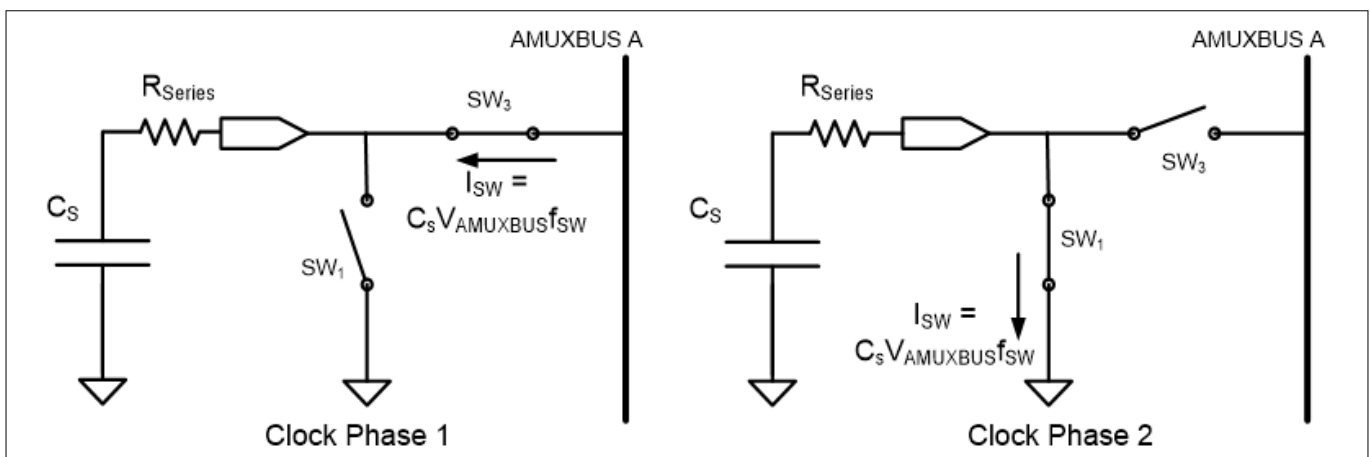

Figure 38 SW_1 and SW_3 switch in non-overlapping manner

If the switches operate at a sufficiently low frequency F_{SW} , such that time $T_{SW}/2$ is sufficient to fully charge the sensor to V_{REF} and fully discharge it to ground, as Figure 38 shows, the value of the equivalent resistance R_S is given by Equation 5.

$$R_S = \frac{1}{C_S F_{SW}}$$

Equation 5 Sensor equivalent resistance

Where,

C_S = Sensor capacitance

F_{SW} = Frequency of the sense clock

The sigma-delta converter maintains the voltage of AMUXBUS A at a constant V_{REF} (this process is explained in [Sigma-delta converter](#). Figure 39 shows the resulting voltage waveform across C_S).

3 PSoC™ 4 and PSoC™ 6 MCU CAPSENSE™

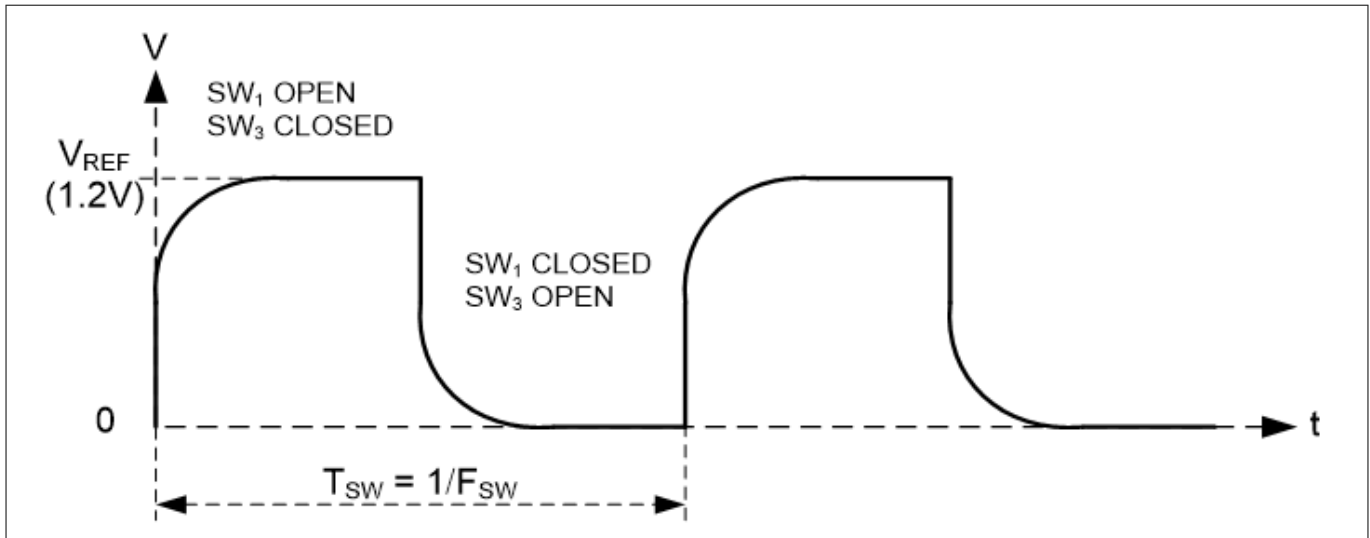

Figure 39 Voltage across sensor capacitance

Equation 6 gives the value of average current taken from AMUXBUS A.

$$I_{CS} = C_S F_{SW} V_{REF}$$

Equation 6 Average current sunk from AMUXBUS A to GPIO through CAPSENSE™ sensor (ICS)

3.2.3 IDAC sinking mode

In the IDAC sinking mode, the GPIO cell sources current to the AMUXBUS A through a switched capacitor circuit as Figure 40 shows. Figure 41 shows the voltage waveform across the sensor capacitance.

Because this mode charges the AMUXBUS A directly through V_{DDD} , it is more susceptible to power supply noise compared to the IDAC sourcing mode. Hence, it is recommended to use this mode with an LDO or a very stable and quiet V_{DDD} .

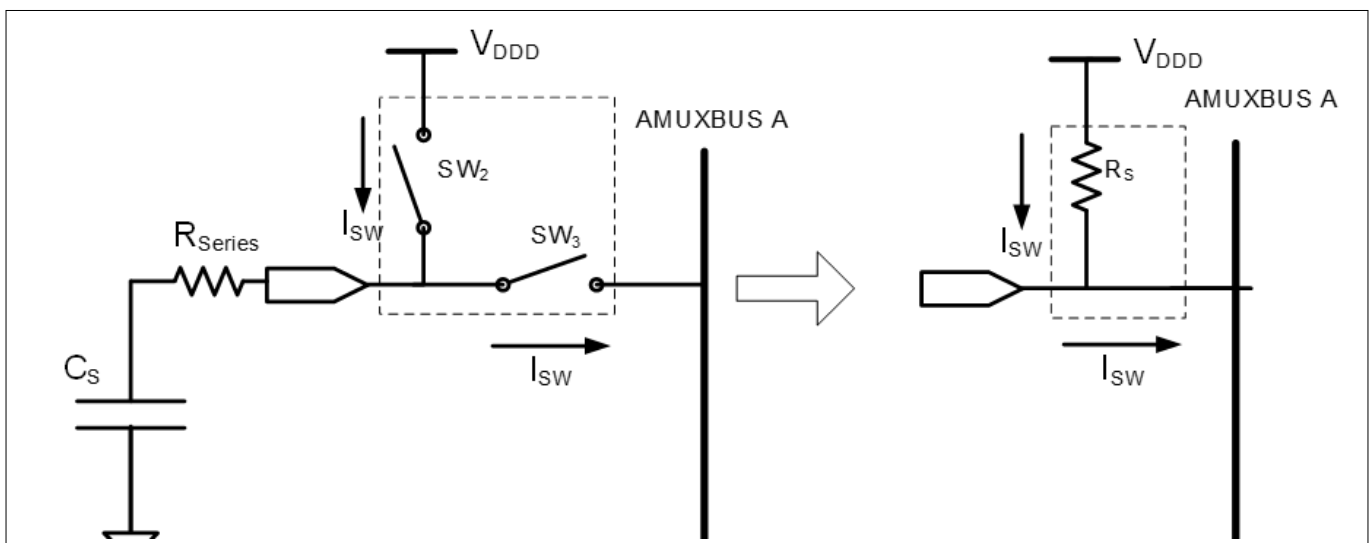

Figure 40 GPIO cell sourcing current to AMUXBUS A

3 PSoC™ 4 and PSoC™ 6 MCU CAPSENSE™

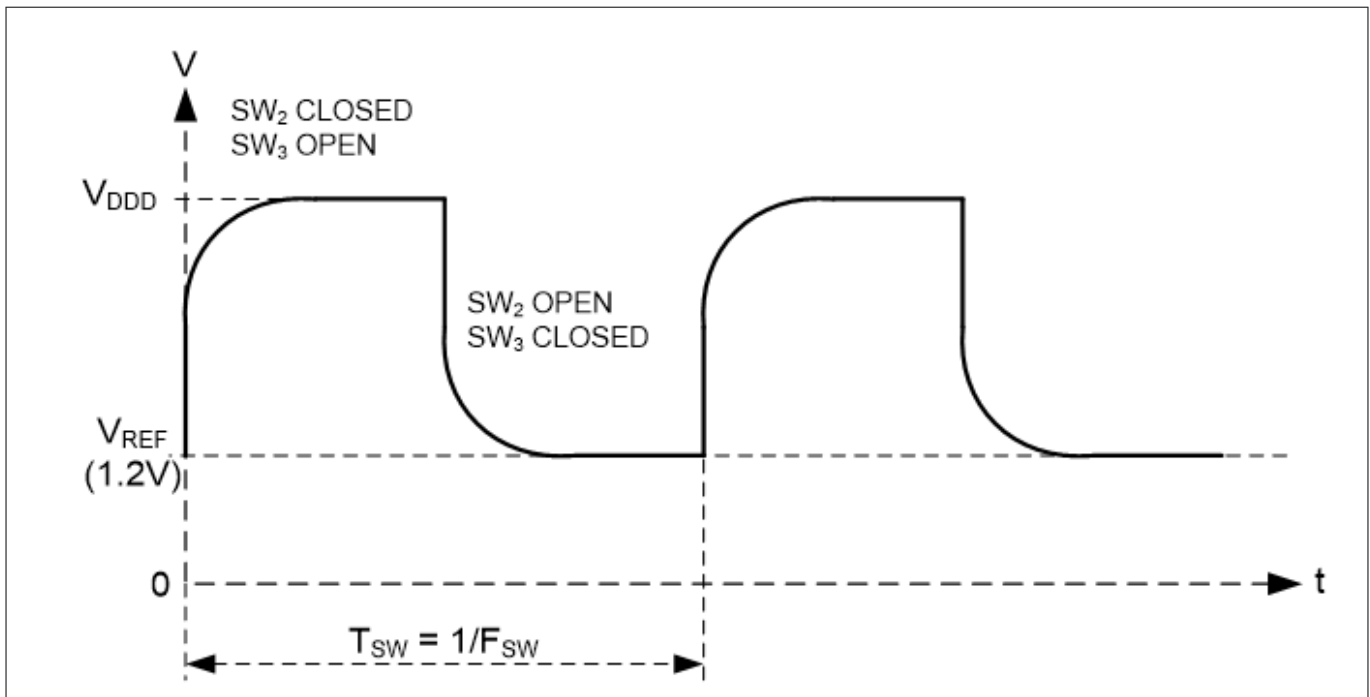

Figure 41 Voltage across sensor capacitance

Equation 7 provides the value of average current supplied to AMUXBUS A.

$$I_{CS} = C_S F_{SW} (V_{DDD} - V_{REF})$$

Equation 7 Average current sourced to AMUXBUS A from GPIO through CAPSENSE™ sensor (ICS)

3.2.4 CAPSENSE™ clock generator

The CAPSENSE™ clock generator block generates the sense clock F_{SW} , and the modulation clock F_{MOD} , from the high-frequency system resource clock (HFCLK) or peripheral clock (PERI) depending on the PSoC™ device family as shown in Figure 35.

3.2.4.1 Sense Clock

The sense clock, also referred to as the switching clock, drives the non-overlapping clocks to the GPIO cell switched capacitor circuits for the [GPIO cell capacitance to charge converter](#).

Sense clock can be sourced from three options: direct, 8-bit PRS, and 12-bit PRS. Some PSoC™ 4 and PSoC™ 6 MCU parts also support additional spread spectrum clock (SSCx) modes. For more details on the supported modes for PSoC™ device, see the [Component datasheet/middleware document](#).

Direct clock is a constant frequency sense clock source. When you chose this option, the sensor pin switches with a constant frequency clock with frequency as specified in the CAPSENSE™ component configuration window.

PRS clock implies that the sense clock is driven from a PRS block, which can generate either 8-bit or 12-bit PRS. Use of the PRS clock spreads the sense clock frequency over a wide frequency range by dividing the input clock using a PRS.

SSCx also spreads the sense clock frequency. It provides better noise immunity and reduces radiated electromagnetic emissions.

See [Manually tuning hardware parameters](#) for details on the clock source and frequency selection guidelines.

3 PSoC™ 4 and PSoC™ 6 MCU CAPSENSE™

3.2.4.2 Modulator clock

The modulation clock is used by the [Sigma-delta converter](#). This clock determines the sensor scan time based on [Equation 8](#) and [Equation 9](#).

$$\text{Sensor scan time} = \text{Hardware scan time} + \text{Sensor Initialization time}$$

Equation 8 **Sensor scan time**

$$\text{Hardware scan time} = \frac{(2^{\text{Resolution}} - 1)}{\text{Modulator Clock Frequency}}$$

Equation 9 **Hardware scan time**

Where,

Resolution = [Scan resolution](#)

Sensor Initialization time = Time taken by the sensor to write to the internal registers and initiate a scan.

3.2.5 Sigma-delta converter

The sigma-delta converter converts the input current to a corresponding digital count. It consists of a sigma-delta converter and two current sourcing/sinking digital-to-analog converters (IDACs) called modulation IDAC and compensation IDAC as [Figure 35](#) shows.

The sigma-delta converter uses an external integrating capacitor, called modulator capacitor C_{MOD} , as [Figure 35](#) shows. Sigma-delta converter controls the modulation IDAC current by switching it ON or OFF corresponding to the small voltage variations across C_{MOD} to maintain the C_{MOD} voltage at V_{REF} . The recommended value of C_{MOD} is listed in [Table 36](#).

The sigma-delta converter can operate in either IDAC sourcing mode or IDAC sinking mode.

- **IDAC sourcing mode:** In this mode, the [GPIO cell capacitance to charge converter](#) sinks current from C_{MOD} through AMUXBUS A, and the IDACs then source current to AMUXBUS A to balance its voltage
- **IDAC sinking mode:** In this mode, the [GPIO cell capacitance to charge converter](#) sources current from C_{MOD} to AMUXBUS A and the IDACs sink current through AMUXBUS A to balance its voltage

In both the above-mentioned modes, the sigma delta converter can operate in either single IDAC mode or dual IDAC mode:

- In the single IDAC mode, the modulation IDAC is controlled by the sigma-delta converter; the compensation IDAC is always OFF
- In the dual IDAC mode, the modulation IDAC is controlled by the sigma-delta converter; the compensation IDAC is always ON

In the single IDAC mode, if 'N' is the resolution of the sigma-delta converter and I_{MOD} is the value of the modulation IDAC current, the approximate value of raw count in the IDAC Sourcing mode is given by [Equation 10](#).

$$\text{raw count} = (2^N - 1) \frac{V_{REF} F_{SW}}{I_{MOD}} C_S$$

Equation 10 **Single IDAC sourcing raw count**

Similarly, the approximate value of raw count in the IDAC sinking mode is given by [Equation 11](#).

3 PSoC™ 4 and PSoC™ 6 MCU CAPSENSE™

$$\text{raw count} = \left(2^N - 1\right) \frac{(V_{DD} - V_{REF}) F_{SW}}{I_{MOD}} C_S$$

Equation 11 Single IDAC sinking raw count

In both cases, the raw count is proportional to sensor capacitance C_S . The raw count is then processed by the CAPSENSE™ CSD Component firmware to detect touches. The hardware parameters such as I_{MOD} , I_{COMP} , and F_{SW} , and the software parameters, should be tuned to optimum values for reliable touch detection. For an in-depth discussion of the tuning, see [CAPSENSE™ performance tuning](#).

In the dual IDAC mode, the compensation IDAC is always ON. If I_{COMP} is the compensation IDAC current, the equation for the raw count in the IDAC sourcing mode is given by [Equation 12](#).

$$\text{raw count} = \left(2^N - 1\right) \frac{V_{REF} F_{SW}}{I_{MOD}} C_S - \left(2^N - 1\right) \frac{I_{COMP}}{I_{MOD}}$$

Equation 12 Dual IDAC sourcing raw count

Raw count in the IDAC sinking mode is given by [Equation 13](#).

$$\text{raw count} = \left(2^N - 1\right) \frac{V_{DD} - V_{REF} F_{SW}}{I_{MOD}} C_S - \left(2^N - 1\right) \frac{I_{COMP}}{I_{MOD}}$$

Equation 13 Dual IDAC sinking raw count

Note: Raw count values are always positive. It is thus imperative to ensure that I_{COMP} is less than $(V_{DD} - V_{REF}) C_S F_{SW}$ for the IDAC sinking mode and I_{COMP} is less than $C_S F_{SW} V_{REF}$ for the IDAC Sourcing mode. [Equation 13](#) does not hold true if $I_{COMP} > V_{REF} C_S F_{SW}$ and [Equation 12](#) does not hold true if $I_{COMP} > (V_{DD} - V_{REF}) C_S F_{SW}$; in these cases, raw counts will be zero.

The relation between the parameters shown in the above equation to the CAPSENSE™ Component parameters is listed in [Table 3](#).

Table 3 Relationship between CAPSENSE™ raw count and CAPSENSE™ hardware parameters

Sl. No.	Parameter	Description	Comments
1	N	Scan resolution	Scan resolution is configurable from 6-bit to 16-bit. See Component datasheet/middleware document for details.
2	V_{REF}	N/A	The V_{REF} value is 1.2 V or configurable between 0.6 V to $V_{DDA} - 0.6$ V depending on the PSoC™ device family. See Component datasheet/middleware document for details.
3	F_{SW}	Sense clock frequency	Sense clock frequency and sense clock source decide the frequency at which the sensor is switching.
		Sense clock source	See Sense Clock for details.
4	I_{MOD}	Modulator IDAC	I_{MOD} = Modulation IDAC current
5	I_{COMP}	Compensation IDAC	I_{COMP} = Compensation IDAC current
6	V_{DD}	N/A	This parameter is the device supply voltage.

(table continues...)

3 PSoC™ 4 and PSoC™ 6 MCU CAPSENSE™

Table 3 (continued) Relationship between CAPSENSE™ raw count and CAPSENSE™ hardware parameters

Sl. No.	Parameter	Description	Comments
7	C_S	N/A	This parameter is the sensor parasitic capacitance.
8	N/A	Modulator clock frequency	Modulator clock divider does not impact raw count. See the Modulator clock section for more details.

3.2.6 Analog multiplexer (AMUX)

The sigma delta converter scans one sensor at a time. An analog multiplexer selects one of the GPIO cells and connects it to the input of the sigma delta converter, as [Figure 35](#) shows. The AMUXBUS A and the GPIO cell switches (see SW3 in [Figure 40](#)) forms this analog multiplexer. AMUXBUS A connects to all GPIOs that support CAPSENSE™. See the corresponding [Device datasheet](#) for a list of port pins that support CAPSENSE™. AMUXBUS A also connects the integrating capacitor C_{MOD} to the sigma-delta converter circuit. AMUXBUS B is used for shielding and is kept at V_{REF} when shield is enabled.

3.2.7 CAPSENSE™ CSD shielding

PSoC™ 4 and PSoC™ 6 MCU CAPSENSE™ supports shield electrodes for liquid tolerance and proximity sensing. CAPSENSE™ has a shielding circuit that drives the shield electrode with a replica of the sensor switching signal to nullify the potential difference between sensors and shield electrode. See [Driven-shield signal and shield electrode](#) Driven-shield signal and shield and [Effect of liquid droplets and liquid stream on a self-capacitance sensor](#) for details on how this is useful for liquid tolerance.

In the sensing circuit, the sigma delta converter keeps the AMUXBUS A at V_{REF} (see [Sigma-delta converter](#)). The GPIO cells generate the sensor waveforms by [switching the sensor](#) between AMUXBUS A and a supply rail (either V_{DD} or ground, depending on the configuration). The shielding circuit works in a similar way; AMUXBUS B is always kept at V_{REF} . The GPIO cell switches the shield between AMUXBUS B and a supply rail (either V_{DD} or ground, the same configuration as the sensor). This process generates a replica of the sensor switching waveform on the shield electrode.

For a large shield layer with high parasitic capacitance, an external capacitor (Csh tank capacitor) is used to enhance the drive capacity of the shield electrode driver.

3.3 CAPSENSE™ CSX sensing method (third- and fourth- generation)

[Figure 42](#) illustrates the CSX sensing circuit. The implementation uses the following hardware sub-blocks from CSD HW.

- An 8-bit IDAC and the sigma delta converter
- AMUXBUS A
- CAPSENSE™ clock generator for Tx clock and modulator clock
- V_{REF} and port pins for Tx and Rx electrodes and external caps
- Two external capacitors (CINTA and CINTB) (see [Table 36](#) for recommended value of these capacitors)

Note: PSoC™ 4100 does not support the CSX sensing method.

3 PSoC™ 4 and PSoC™ 6 MCU CAPSENSE™

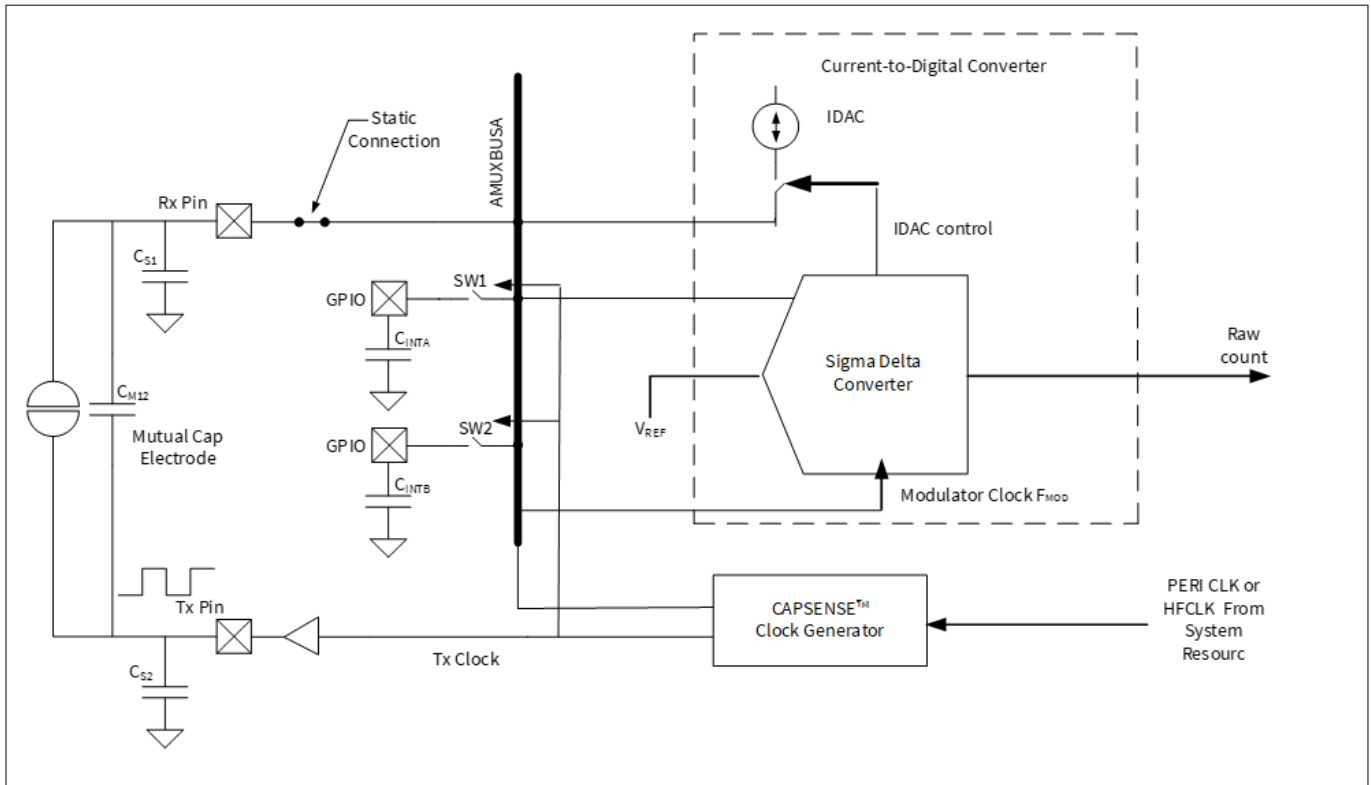

Figure 42 CAPSENSE™ CSX sensing method configuration

The CSX sensing method measures the mutual-capacitance between the Tx electrode and Rx electrode, as shown in Figure 42. The Tx electrode is excited by a digital waveform (Tx clock), which switches between V_{DDIO} (or V_{DD} if V_{DDIO} is not available in the given part number) and ground. The Rx electrode is statically connected to AMUXBUS A. The CSX method requires two external integration capacitors, C_{INTA} and C_{INTB} . The value of these capacitors is listed in Table 36.

3 PSoC™ 4 and PSoC™ 6 MCU CAPSENSE™

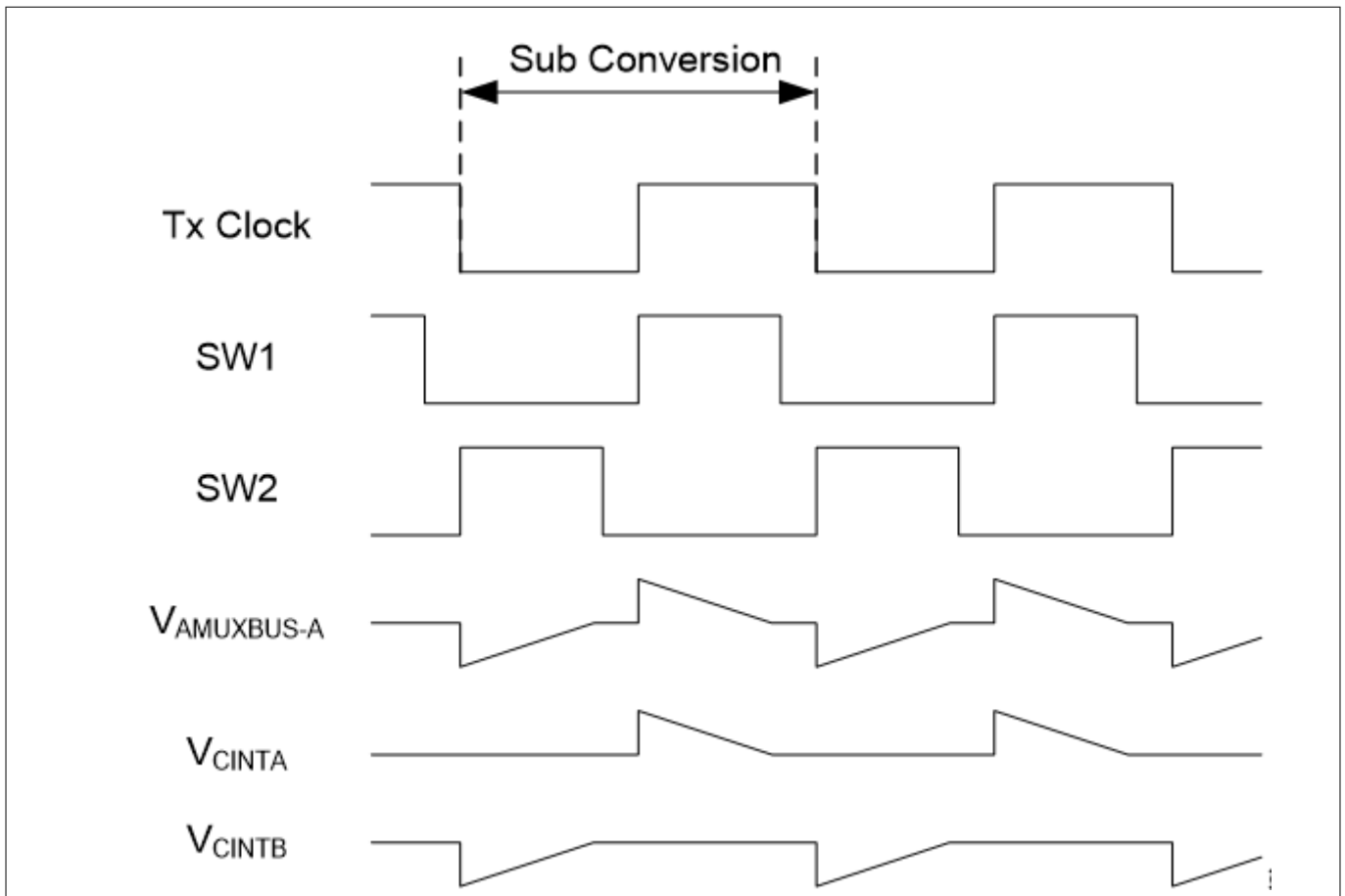

Figure 43 CSX sensing waveforms

Figure 43 shows the voltage waveforms on the Tx electrode and C_{INTA} and C_{INTB} capacitors. The sampling – a process of producing a “sample” – is started by the firmware by initializing the voltage on both external capacitors to V_{REF} and performing a series of sub-conversions. A sub-conversion is a capacitance to count conversions performed within a Tx clock cycle. The sum of results of all sub-conversions in a sample is referred to as “raw count”.

During a sub-conversion, both SW1 and SW2 switches are operated in phase with the Tx clock. On the rising edge of the Tx clock, SW1 is closed (SW2 is open during this time) and charge flows from the Tx electrode to the Rx electrode. This charge is integrated onto the C_{INTA} capacitor, which increases the voltage on C_{INTA} . The IDAC is configured in sink mode to discharge the C_{INTA} capacitor back to voltage V_{REF} . On the falling edge of the Tx clock, SW2 is closed (SW1 is open during this time) and the charge flows from the Rx electrode to the Tx electrode. This causes the voltage on C_{INTB} to go below V_{REF} . The IDAC is configured in source mode to bring the voltage on C_{INTB} back to V_{REF} .

The charge transferred between Tx and Rx electrodes in both the cycles is proportional to mutual-capacitance, C_M , between the electrodes. The sigma delta converter controls IDAC for charging or discharging the external capacitors and also it measures the charging and discharging time in terms of modulator clock cycles for a sub-conversion. Multiple sub-conversions are performed during the CSX scanning and the result of each sub-conversion is accumulated to produce “raw count” for a sensor.

The modulator clock is used to measure the time taken to charge/discharge external capacitors within a Tx clock cycle. For this reason, modulator clock frequency must be always greater than Tx clock frequency; higher modulator clock frequency leads to better accuracy. For proper operation, the IDAC current should be set such that the C_{INTA} and C_{INTB} capacitors are charged/discharged within one Tx clock cycle. The CAPSENSE™ Component/middleware provides an option to automatically calibrate the IDAC. It is recommended to enable this option.

3 PSoC™ 4 and PSoC™ 6 MCU CAPSENSE™

$$Rawcount_{Counter} = \frac{2 V_{TX} F_{TX} C_M MaxCount}{IDAC}$$

$$MaxCount = \frac{F_{Mod} N_{Sub}}{F_{TX}}$$

Equation 14 Raw count relationship for mutual-capacitance sensing

Where,

IDAC = IDAC current

C_M = Mutual-capacitance between Tx and Rx electrodes

V_{TX} = Amplitude of the Tx signal

F_{TX} = Tx clock frequency

F_{Mod} = Modulator clock frequency

N_{Sub} = Number of sub-conversions

When you place a finger on the CSX button, the mutual-capacitance between Rx and Tx electrodes decreases, which decreases the raw count. This decrease in raw count from the hardware is inverted by the CAPSENSE™ Component to make it similar to the raw count change in CSD for a finger touch. The final resulting inverted raw count is given by [Equation 15](#).

$$Rawcount_{Component} = MaxCount - Rawcount_{Counter}$$

Equation 15 Formula to determine rawcount_{Component}

See [CSX sensing method \(third- and fourth-generation\)](#) for more details of CSX hardware parameters.

3.4 CAPSENSE™ CSD-RM sensing method (fifth-generation and fifth-generation low-power)

This section provides an overview of the CSD-RM architecture implemented in the fifth-generation CAPSENSE™ device (known as multi sense converter (MSC)). The main features include ratiometric sensing, differential mode of operation without the need of reference voltage, use of capacitor DACs (CDAC) instead of current DACs (IDAC), which improves noise performance.

3 PSoC™ 4 and PSoC™ 6 MCU CAPSENSE™

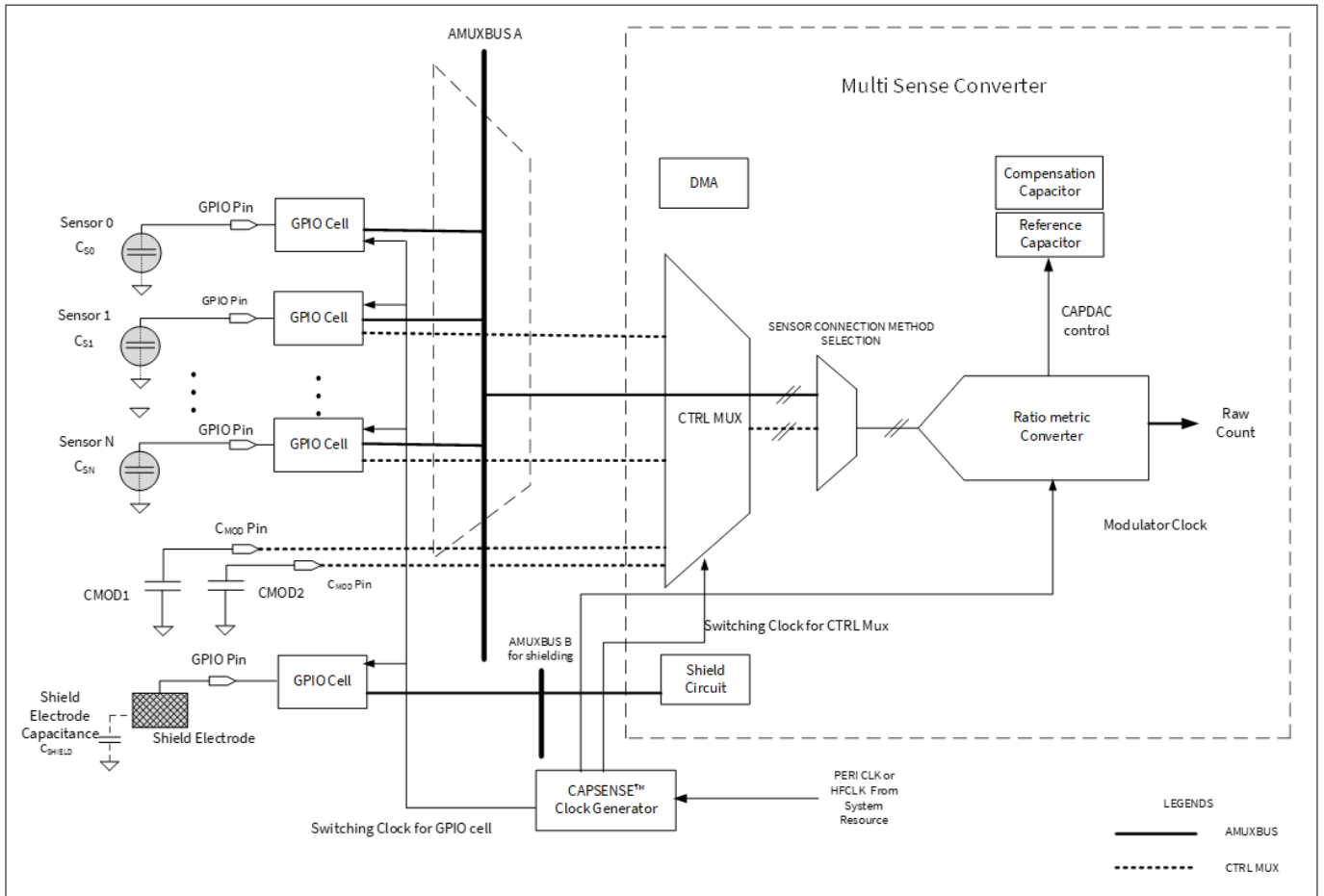

Figure 44 CAPSENSE™ CSD-RM (fifth-generation)

The fifth-generation low power (known as multi-sense low-power or MSCLP) technology has an internal clock removing the dependency on the system resource. [Autonomous scanning](#) is now enabled even without the CTRLMUX and DMA. All AMUXBUS CAPSENSE™ pins support autonomous scanning.

3 PSoC™ 4 and PSoC™ 6 MCU CAPSENSE™

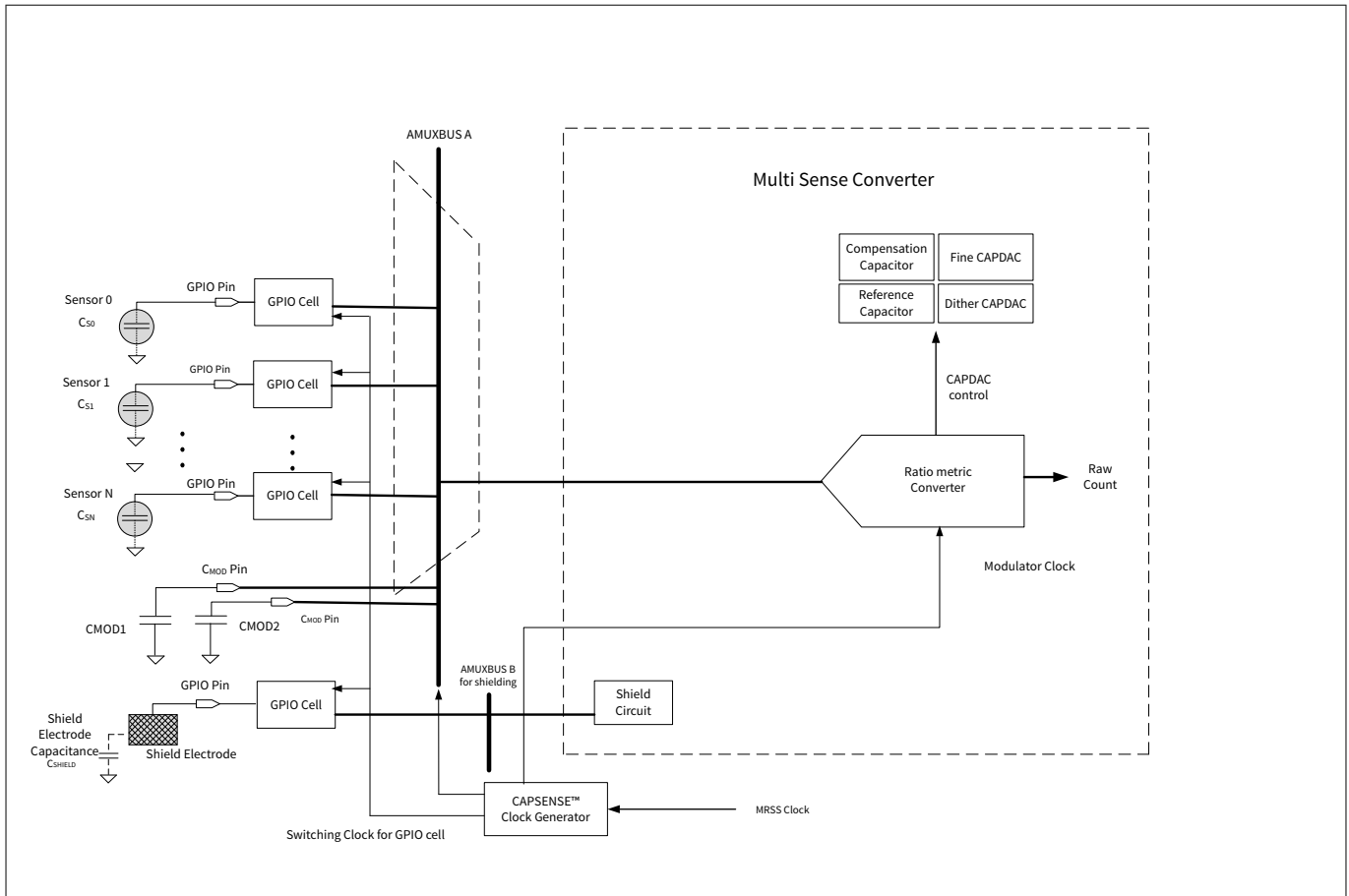

Figure 45 CAPSENSE™ CSD-RM (fifth-generation low-power)

3.4.1 GPIO cell capacitance to charge converter

Chapter 3.2.1 explains the GPIO cell configuration. In the fifth-generation architecture, the sensor is either interfaced to the AMUX (as before) or a new control MUX matrix, which supports autonomous scanning (limited number of pins supported). The GPIO cells are configured as switched-capacitance circuits that convert sensor capacitance into equivalent charge transfer. Figure 46 shows the GPIO cell structure.

3 PSoC™ 4 and PSoC™ 6 MCU CAPSENSE™

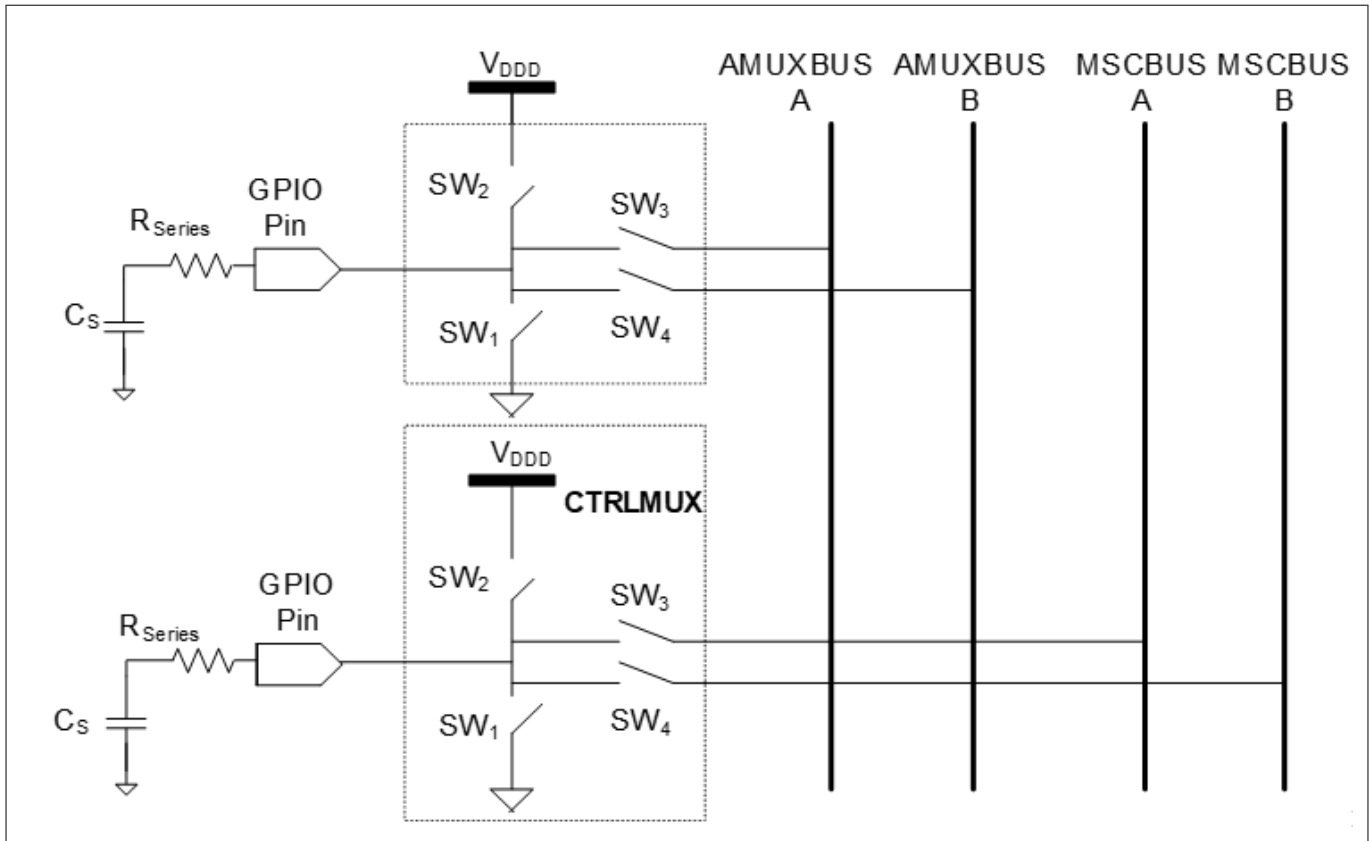

Figure 46 GPIO cell structure (fifth-generation)

In the fifth-generation low-power architecture, the sensor is only interfaced to the AMUX, which now supports autonomous scanning (supports more number of pins than CTRLMUX).

3 PSoC™ 4 and PSoC™ 6 MCU CAPSENSE™

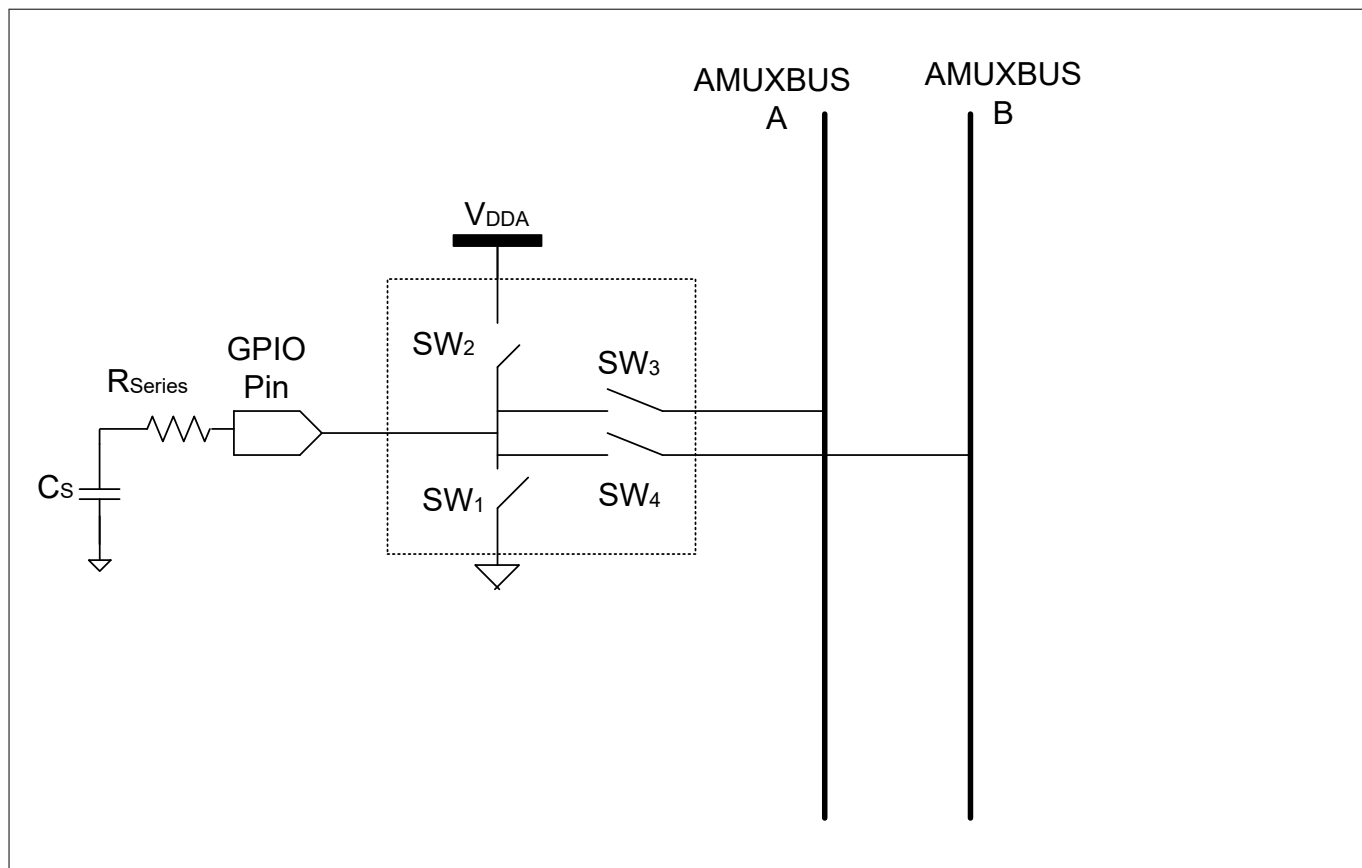

Figure 47 GPIO cell structure (fifth-generation low-power)

Four non-overlapping, out-of-phase clocks of frequency F_{SW} control the switches (SW1, SW2, SW3 and SW4) as Figure 48 shows.

3 PSoC™ 4 and PSoC™ 6 MCU CAPSENSE™

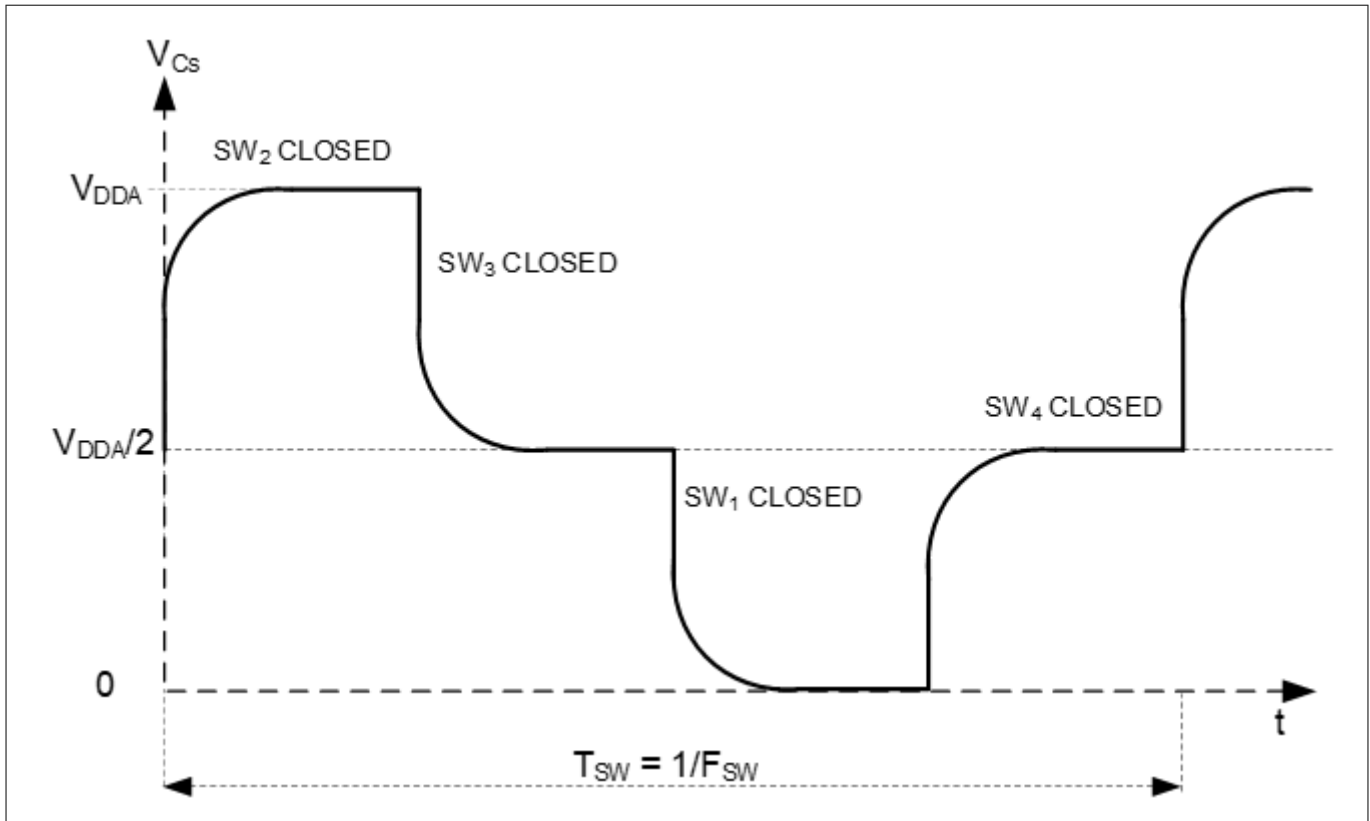

Figure 48 Voltage across sensor capacitance

3.4.2 Capacitor DACs (CDACs)

IDACs are replaced by CDACs in the fifth-generation CAPSENSE™ architecture. It consists of two CDACs, a reference capacitor DAC, and a compensation capacitor DAC. In each sense clock period, the sensor capacitance, as mentioned in [GPIO cell capacitance to charge converter](#), transfers charge to both C_{MODS} in such a way that it affects the voltage balance between the C_{MODS} . Both capacitor DACs are switched on to C_{MOD} multiple times during a sense clock period to restore the voltage balance between the C_{MODS} . The number of cycles required by the reference capacitor DAC to balance the voltage is proportional to the self-capacitance of the sensors.

The fifth-generation low-power CAPSENSE™ consists of Fine CDAC and Dither CDAC. The Fine CDAC is a programmable CDAC, which is used to achieve finer resolution for the Reference CDAC. The [CDAC dither](#) is used to reduce [Flat-spots](#) (or dead zones).

3.4.3 CAPSENSE™ clock generator

This block generates the sense clock F_{SW} , and the modulation clock F_{MOD} , from the high-frequency system resource clock (HFCLK) or peripheral clock (PERI) depending on the PSoC™ device family.

3.4.3.1 Sense clock

CAPSENSE™ clock generation is similar to that in the older generation as explained in [Chapter 3.2.4.1](#).

3 PSoC™ 4 and PSoC™ 6 MCU CAPSENSE™

3.4.3.2 Modulator clock

The modulation clock is used by the [Ratiometric sensing technology](#). This clock determines the sensor scan time based on [Equation 16](#) and [Equation 17](#).

$$\text{Sensor scan time} = \text{Hardware scan time} + \text{Sensor initialization time}$$

Equation 16 **Sensor scan time**

$$\text{Hardware scan time} = \frac{(\text{Number of subconversions})}{\text{Sense clock frequency}}$$

Equation 17 **Hardware scan time**

Where,

Number of subconversions = Total number or sub-conversions in single scan

Subconversion = Capacitance to count conversions performed within a sense clock cycle

Sensor initialization time = Time taken by the sensor to write to the internal registers and initiate a scan

3.4.4 Ratiometric sensing technology

It consists of a ratiometric converter and two CDACs, a reference capacitor DAC, and a compensation capacitor DAC. In each sense clock period, the sensor capacitance, as mentioned in [GPIO cell capacitance to charge converter](#), transfers charge to both C_{MODS} in such a way that it affects the voltage balance between the C_{MODS} . The ratiometric converter controls the reference CDAC by switching it ON or OFF corresponding to the small voltage variations across two C_{MODS} to maintain the C_{MOD} voltage at the same level. The number of cycles required by the reference capacitor DAC to balance the voltage between the C_{MODS} is proportional to the self-capacitance of the sensors.

The compensation capacitor is used to compensate excess mutual-capacitance from the sensor to increase the sensitivity. The number of times it is switched depends on the amount of charge the user application is trying to compensate (remove) from the sensor mutual capacitance.

The ratiometric converter can operate in either the single CDAC mode or dual CDAC mode.

- In the single CDAC mode, the reference CDAC is controlled by the ratiometric converter; the compensation CDAC is always OFF
- In the dual CDAC mode, the reference CDAC is controlled by the ratiometric converter; the compensation CDAC is always ON. The reference CDAC is capable of compensating up to 95%, results in the increased signal as explained in [Conversion gain and CAPSENSE signal](#)

In the single CDAC mode, if C_{REF} is the value of the reference CDAC, the approximate raw count value is given by [Equation 18](#).

$$\text{Rawcount} = \text{Maxcount} \cdot \frac{C_S}{\text{SnsClk}_{Div} \cdot C_{ref}}$$

Equation 18 **CSD-RM single CDAC raw count**

In the dual CDAC mode, the compensation CDAC is always ON. If C_{COMP} is the compensation CDAC, the raw count equation is given by [Equation 19](#).

3 PSoC™ 4 and PSoC™ 6 MCU CAPSENSE™

$$\text{Rawcount} = \text{Maxcount} \cdot \frac{C_S - 2 \cdot \frac{\text{SnsClk}_{\text{Div}}}{\text{CompClk}_{\text{Div}}} \cdot C_{\text{comp}}}{\text{SnsClk}_{\text{Div}} \cdot C_{\text{ref}}}$$

Equation 19 CSD-RM dual CDAC raw count

Where,

$$\text{MaxCount} = N_{\text{Sub}} \cdot \text{SnsClk}_{\text{Div}}$$

With **CIC2** enabled,

$$\text{MaxCount} = \frac{\text{Decimation Rate}^2 \cdot \text{No. of CIC2 samples}}{\text{CIC2 Hardware divider}}$$

Equation 20

N_{Sub} = Number of sub-conversions

$\text{SnsClk}_{\text{Div}}$ = Sense clock divider

$\text{CompClk}_{\text{Div}}$ = Compensation CDAC divider

C_S = Sensor capacitance

C_{ref} = Reference capacitance

C_{comp} = Compensation capacitance

As per [Equation 18](#), the output raw count is proportional to the ratio of sensor capacitance to the reference capacitance, and hence the name Ratiometric Sensing.

Noise improvement is one of the main advantages of the fifth-generation over previous generations of CAPSENSE™ technology. The dominant noise sources in the fourth-generation are current (I_{MOD}), reference voltage (V_{REF}), and clock jitter (F_{SW}) (see [Equation 12](#)). These noise sources have been removed in the fifth-generation (see [Equation 19](#)). The IDAC has been replaced with CDAC. Since the system is now fully differential, it does not need V_{REF} . The CAPSENSE™ architecture is no longer affected by jitter as the scan result is now based on the edges of the clock rather than the duration of the clock.

3.4.5 Analog multiplexer (AMUX) and control matrix (CTRLMUX)

Another feature introduced in the Fifth-Generation is the control matrix (CTRLMUX) as shown in [Figure 44](#). The CTRLMUX enables autonomous scanning and provides immunity to on-chip IO noise. The CTRLMUX allows the CAPSENSE™ IP to directly handle the sensor inputs⁴⁾ (in addition to the traditional GPIO mode), and hence supports autonomous scanning of the sensors without the CPU.

For fifth-generation low-power, as shown in the image [Figure 45](#), the CTRLMUX has been removed. The AMUXBUS is enabled to handle autonomous scanning on all the CAPSENSE™ pins.

3.4.6 CAPSENSE™ CSDRM shielding

PSoC™ 4 CAPSENSE™ supports shield electrodes for liquid tolerance and proximity sensing. The purpose of the shielding is to remove the parasitic capacitance between the sensor and shield electrodes. See [Driven-shield signal and shield electrode](#) and [Effect of liquid droplets and liquid stream on a self-capacitance sensor](#) for details on how this is useful for liquid tolerance. The fifth-generation CAPSENSE™ architecture supports two shield modes – active and passive shielding.

⁴ Supports limited number of inputs. Refer to the [device datasheet](#) for more details

3 PSoC™ 4 and PSoC™ 6 MCU CAPSENSE™

3.4.6.1 Active shielding

In active shielding mode, the shield circuit drives the shield electrode with a replica of the sensor signal using a buffer as shown in Figure 49. This nullifies the potential difference between sensors and the shield electrode.

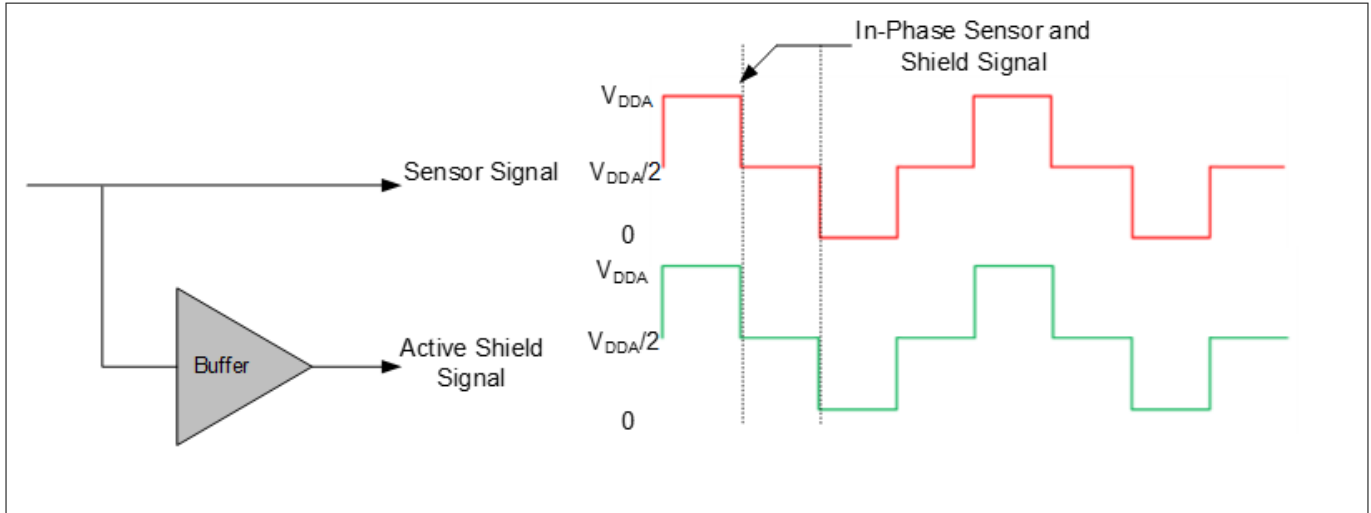

Figure 49 Active shield signal

3.4.6.2 Passive shielding

In the passive shielding mode, there is no buffer used; instead, the shield is switched between V_{DDA} and GND as shown in Figure 50. The switching is controlled in such a way that the net charge between the sensor and the shield is nullified every two sense clocks.

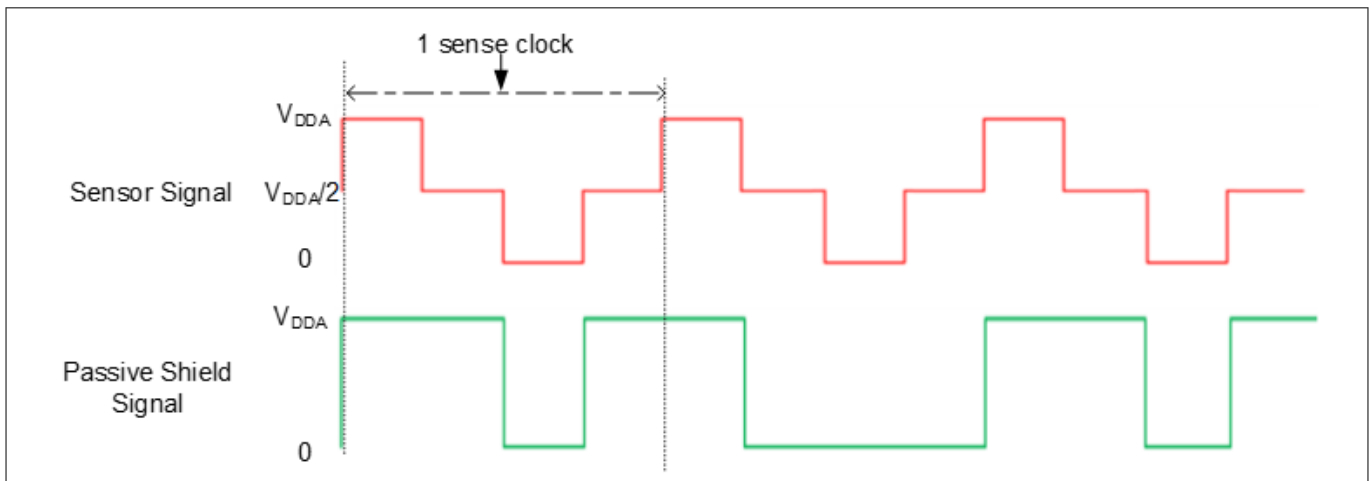

Figure 50 Passive shield signal

Table 4 provides the comparison of the active shielding features versus the passive shielding features.

Table 4 Active vs passive shielding

Feature	Active shielding	Passive shielding	Effect
Performance	Higher	Lower	Active shielding is preferred for high-performance applications.
Power impact	Higher	Lower	Passive shielding is preferred for low-power applications.

3 PSoc™ 4 and PSoc™ 6 MCU CAPSENSE™

3.5 CAPSENSE™ CSX-RM sensing method (fifth-generation and fifth-generation low-power)

Figure 51 illustrates the CSX-RM sensing circuit. The implementation uses the following hardware subblocks:

- Two 8-bit capacitor DACs and ratiometric converter
- AMUXBUS and CTRLMUX
- CAPSENSE™ clock generator for Tx clock and modulator clock
- Port pins for Tx and Rx electrodes and external caps
- Two external capacitors (C_{MOD1} and C_{MOD2})

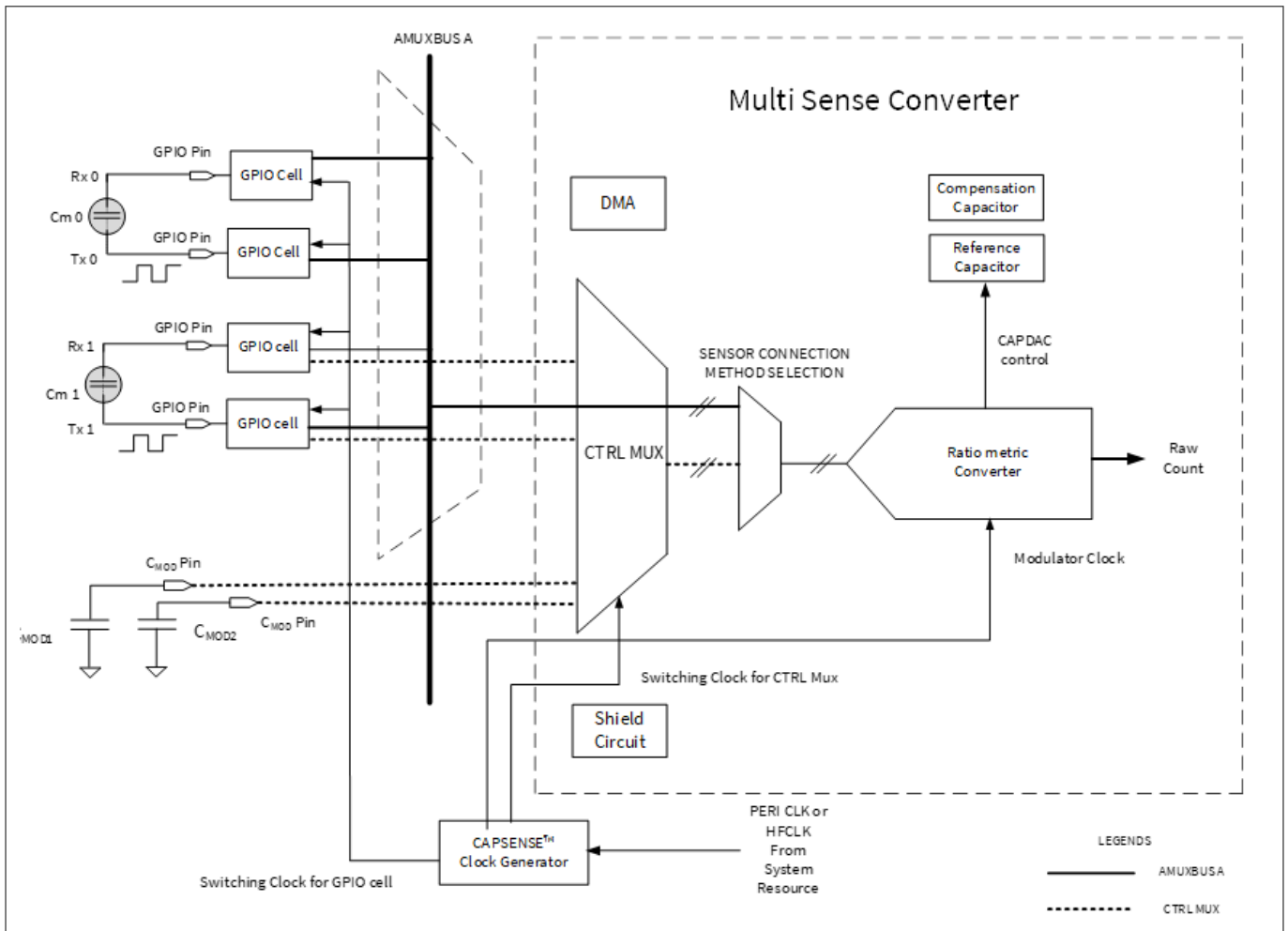

Figure 51 CAPSENSE™ CSX-RM sensing method configuration (fifth-generation)

3 PSoC™ 4 and PSoC™ 6 MCU CAPSENSE™

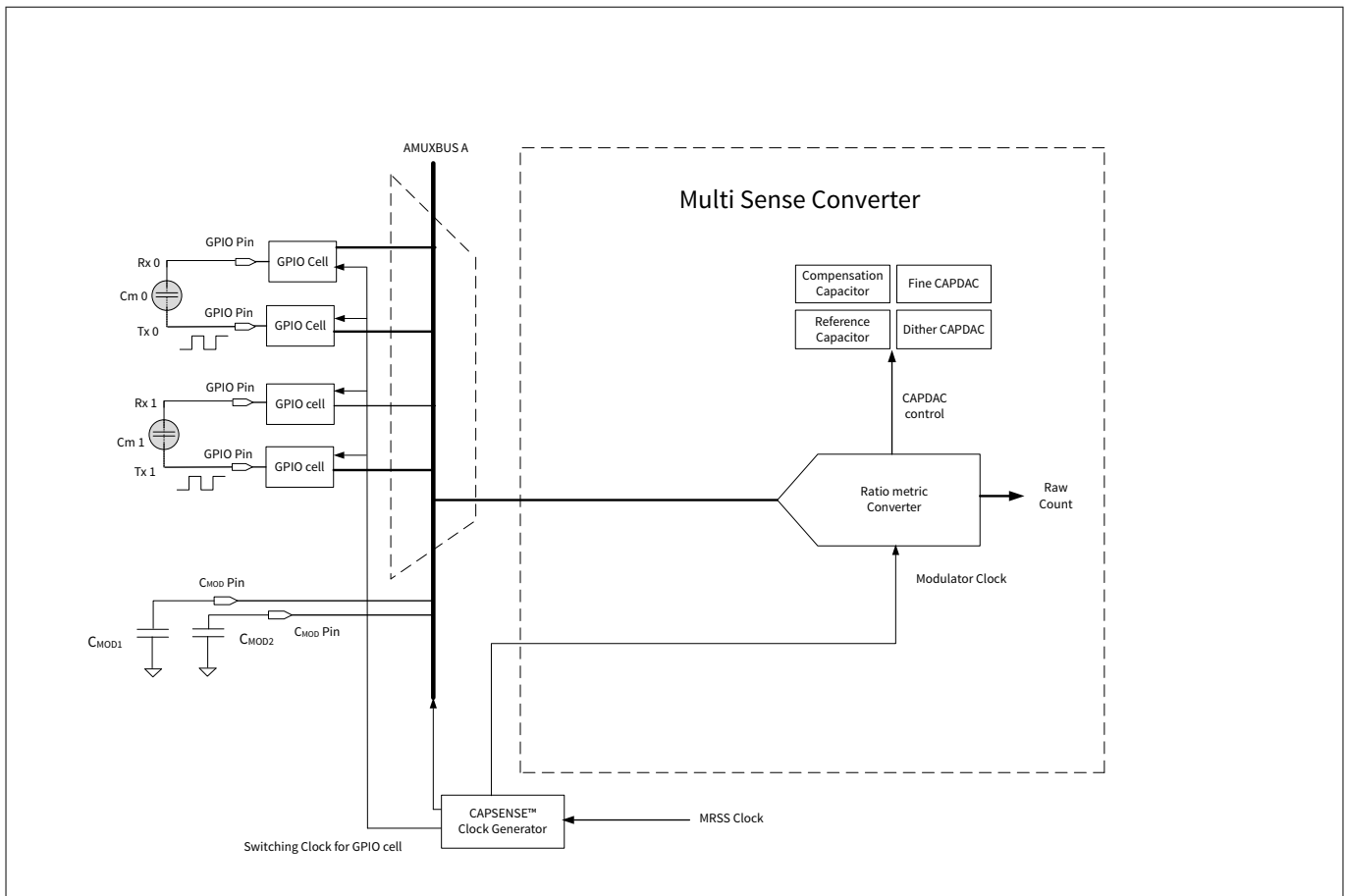

Figure 52 CAPSENSE™ CSX-RM sensing method configuration (fifth-generation low-power)

The CSX-RM sensing method measures the mutual-capacitance between the Tx electrode and Rx electrode, as shown in Figure 51. The Tx electrode is activated by a digital waveform (Tx clock), which switches between V_{DDA} and ground. The Rx electrode is statically connected to AMUXBUS A or CTRLMUX, as applicable. The CSX-RM method requires two external integration capacitors, C_{MOD1} and C_{MOD2} .

The sampling – a process of producing a “sample” – is started by the firmware by initializing the voltage on both external capacitors (C_{MOD}) to $V_{DDA}/2$ and performing a series of sub-conversions. A sub-conversion is a capacitance to count conversions performed within a Tx clock cycle. The sum of results of all sub-conversions in a sample is referred to as “raw count”.

On the rising and falling edge of the Tx clock, charge flows from the Tx electrode to the Rx electrode. In such a way that it unbalances the voltage between the external C_{MOD} capacitors. Both capacitor DACs (reference and compensation capacitor DACs) are switched onto C_{MOD} multiple times during a sense clock period to balance the C_{MOD} 's back to their original voltage. Number of cycles required by the reference capacitor DAC to balance is proportional to the mutual-capacitance, C_m , between the electrodes.

The number of times the reference capacitor is switched with respect to the modulator clock is denoted by the Tx clock divider value according to Equation 21.

$$TxClk_{Div} = \frac{F_{Mod}}{F_{Tx}}$$

Equation 21 Tx clock divider

Where,

$TxClk_{Div}$ = Tx clock divider

F_{Mod} = Modulator frequency

3 PSoC™ 4 and PSoC™ 6 MCU CAPSENSE™

F_{Tx} = Tx clock frequency

The compensation capacitor is used to compensate excess mutual-capacitance from the sensor to increase the sensitivity. The number of times it is switched depends on the amount of charge the user application is trying to compensate (remove) from the sensor mutual-capacitance. The number of times the compensation capacitor is switched with respect to the modulator clock is denoted by the value of the compensation CDAC divider according to the [Equation 21](#). The CDAC compensation clock divider must be less than or equal to the Tx clock divider.

$$CompClk_{Div} = \frac{F_{MOD}}{F_{comp}}$$

Equation 22 Compensation CDAC divider

Where,

$CompClk_{Div}$ = Compensation CDAC divider

F_{MOD} = Modulator frequency

F_{comp} = Compensation CDAC clock frequency

3.5.1 Ratiometric sensing technology

The ratiometric converter gives an equivalent raw count which is proportional to the sensor mutual-capacitance after each scan. The ratiometric converter can operate in either single CDAC mode or dual CDAC mode.

- In the single CDAC mode, the reference CDAC is controlled by the ratiometric converter; the compensation CDAC is always OFF
- In the dual CDAC mode, the reference CDAC is controlled by the ratiometric converter; the compensation CDAC is always ON. Compensation CDAC is capable of compensating up to 95%, results in increased signal as explained in [Conversion gain and CAPSENSE™ signal](#)

In the single CDAC mode, if C_{ref} is the value of the reference CDAC, the approximate value of raw count is given by [Equation 22](#).

$$Rawcount = Maxcount \cdot \frac{C_M}{TxClk_{Div} \cdot \left(\frac{C_{ref}}{2}\right)}$$

Equation 23 CSX-RM single CDAC raw count

In the dual CDAC mode, the compensation CDAC is always ON. If C_{comp} is the compensation CDAC, the equation for the raw count is given by [Equation 23](#).

$$Rawcount = Maxcount \cdot \frac{C_M - \frac{TxClk_{Div}}{CompClk_{Div}} \cdot C_{comp}}{TxClk_{Div} \cdot \left(\frac{C_{ref}}{2}\right)}$$

Equation 24 CSX-RM dual CDAC raw count

Where,

$MaxCount = N_{Sub} \cdot TxClk_{Div}$

With [CIC2](#) enabled,

3 PSoC™ 4 and PSoC™ 6 MCU CAPSENSE™

$$\text{MaxCount} = \frac{\text{Decimation Rate}^2 * \text{No. of CIC2 samples}}{\text{CIC2 Hardware divider}}$$

Equation 25

N_{Sub} = Number of sub-conversions

$\text{TxClk}_{\text{Div}}$ = Tx clock divider

$\text{CompClk}_{\text{Div}}$ = CDAC compensation divider

C_M = Mutual-capacitance of the sensor

C_{ref} = Reference capacitance

C_{comp} = Compensation capacitance

According to [Equation 23](#), the output raw count is proportional to the ratio of mutual-capacitance of the sensor to the reference capacitance, and hence the name ratiometric sensing.

3.6 Advantages of fifth generation and fifth generation low-power

3.6.1 Autonomous scanning

In previous generation CAPSENSE™ technology, after each scan, CPU is interrupted to configure the next sensor. Autonomous scanning mode in the fifth-generation CAPSENSE™ technology avoids the CPU intervention for scanning every subsequent sensor. This significantly reduces the CPU bandwidth required for scanning widgets with large number of sensors. Autonomous scanning requires features such as CTRLMUX and DMA. Since the number of pins supported with CTRLMUX is limited, the number of pins supporting autonomous scanning is also limited. See the [Configuring autonomous scan](#) section for more details.

In fifth-generation low-power CAPSENSE™, autonomous scanning is supported inherently, and requires neither CPU intervention nor CTRLMUX and DMA. All CAPSENSE™ pins support this scanning mode, via the AMUXBUS, compared to the limited number of pins, which were supported by the CTRLMUX in the fifth-generation CAPSENSE™ technology.

3.6.2 Usage of multiple channels

The PSoC™ 4100S Max device supports two fifth-generation CAPSENSE™ blocks – MSC0 and MSC1. Each block has the same functionality and performance as explained in the [CAPSENSE™ CSD-RM sensing method \(fifth-generation and fifth-generation low-power\)](#) and [CAPSENSE™ CSX-RM sensing method \(fifth-generation and fifth-generation low-power\)](#) sections. Each instance can be considered as a channel and multiple instances imply multiple channels. Multi-channel behavior can be supported by multiple instances in a single chip and/or having multiple chips. The operation of the channels is synchronized and operate in lockstep when scanning the sensors hooked in to the channels. Lockstep guarantees clock synchronization and avoids any cross-channel noise due to un-synchronized sense clocks.

See [Multi-channel scanning](#) section for more details.

3.6.3 CIC2

Multi-sense low-power (MSCLP) CAPSENSE™ has a built-in cascaded integrator-comb 2 (CIC2) digital filter, which improves the effective resolution, and thereby the SNR, for a given scan period. The CIC2 filter is a 2nd order digital low-pass (decimation) filter used to filter delta-sigma converters. [Figure 53](#) shows the representation of a CIC2 filter made up of a cascade of two integrators and two comb filters.

3 PSoC™ 4 and PSoC™ 6 MCU CAPSENSE™

The CIC2 filter receives the output of the MSCLP analog front end, which is a delta-sigma converter. This converter generates a bitstream of 1s and 0s representing its input and moves the quantization noise to high frequencies. This high-frequency noise is filtered out by a digital low-pass filter; the downsampler converts the input to a single digital word representing the measured signal. This combination of a low-pass filter (A0, A1) and a downsampler (D0, D1) is known as decimator (CIC2 filter) as shown in Figure 53.

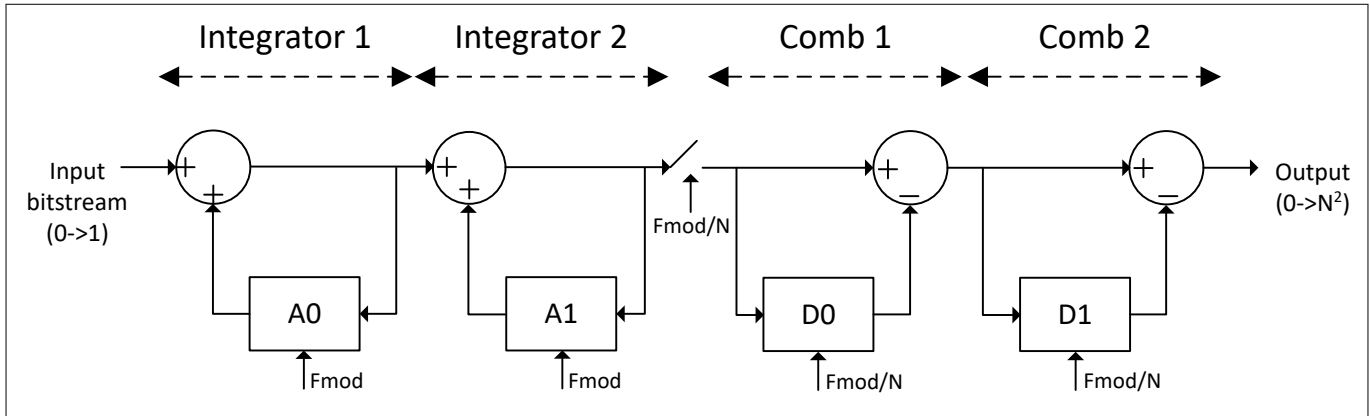

Figure 53 CIC2 filter block diagram

The number of valid CIC2 samples can be calculated using the following equation:

$$\text{No. of valid CIC2 samples} = \text{FLOOR} \left[\frac{\text{Sns_Clk_Div} * \text{Nsub}}{\text{Decimation Rate}} - 1 \right]$$

Equation 26 Number of CIC2 samples

Where, *Decimation Rate* is the down sampling rate.

Note: CIC2 filters discard the first sample.

The raw count gets accumulated at the end of each valid sample.

A minimum of two valid CIC2 samples are required for proper CIC2 filtering. Considering this and rearranging Equation 8, we get the decimation rate, which can be calculated using the following equation:

$$\text{Decimation Rate}(N) = \frac{\text{Sns_Clk_Div} * \text{Nsub}}{3}$$

Equation 27 Decimation rate

The max raw count can be calculated using the following equation:

$$\text{Rawcount}_{max} = \text{Decimation Rate}^2 * K$$

Equation 28 Max rawcount equation

where,

$$K = \frac{\text{No. of CIC2 samples}}{\text{CIC2 Hardware divider}}$$

Equation 29

It is recommended to choose the number of CIC2 samples in such a way that “K” can be set to “1” to get highest possible raw count.

3 PSoC™ 4 and PSoC™ 6 MCU CAPSENSE™

Table 5 **CIC2 hardware divider look-up table**

Number of CIC2 samples	Recommended CIC2 shift for the divider	CIC2 hardware divider
3-4	2	4
5-8	3	8
9-16	4	16
17-32	5	32
33-64	6	64
65-128	7	128
129-256	8	256

Selecting the Auto option for CIC2 shift in the CAPSENSE™ configurator selects hardware shifts (hardware divider) as per [Table 5](#).

4 CAPSENSE™ design and development tools

4 CAPSENSE™ design and development tools

This section introduces the available software tools, such as PSoC™ Creator and ModusToolbox™, to develop your CAPSENSE™ application. For more details, see the user manual of the respective IDE. [Table 6](#) shows the supported devices and the CAPSENSE™ component/middleware version in PSoC™ Creator and ModusToolbox™.

Table 6 Tools and supported devices

Devices	Software tool	CAPSENSE™ library
PSoC™ 4000S, PSoC™ 4100S, PSoC™ 4100S Plus, PSoC™ 4100S Plus 256K, PSoC™ 4500S	ModusToolbox™ , PSoC™ Creator	CAPSENSE™ middleware, CAPSENSE™ component
PSoC™ 4000T, PSoC™ 4100S Max, All PSoC™ 6 devices	ModusToolbox™	CAPSENSE™ middleware
All other PSoC™ 4 devices	PSoC™ Creator	CAPSENSE™ component

4.1 PSoC™ Creator

PSoC™ Creator is a state-of-the-art, easy-to-use IDE. It offers a unique combination of hardware configuration and software development based on classical schematic entry. You can develop applications in a drag-and-drop design environment using a library of Components. For details, see the [PSoC™ Creator home page](#).

4.1.1 CAPSENSE™ component

PSoC™ Creator provides a CAPSENSE™ component, which is used to create a capacitive touch system in PSoC™ by simply configuring this Component. The CAPSENSE™ component also provides an application programming interface (API) to simplify firmware development. Some PSoC™ 4 Bluetooth® LE and PSoC™ 6 MCU devices also support a CAPSENSE™ Gesture Component (see the corresponding [Device datasheet](#) to see if your device supports this Component).

4 CAPSENSE™ design and development tools

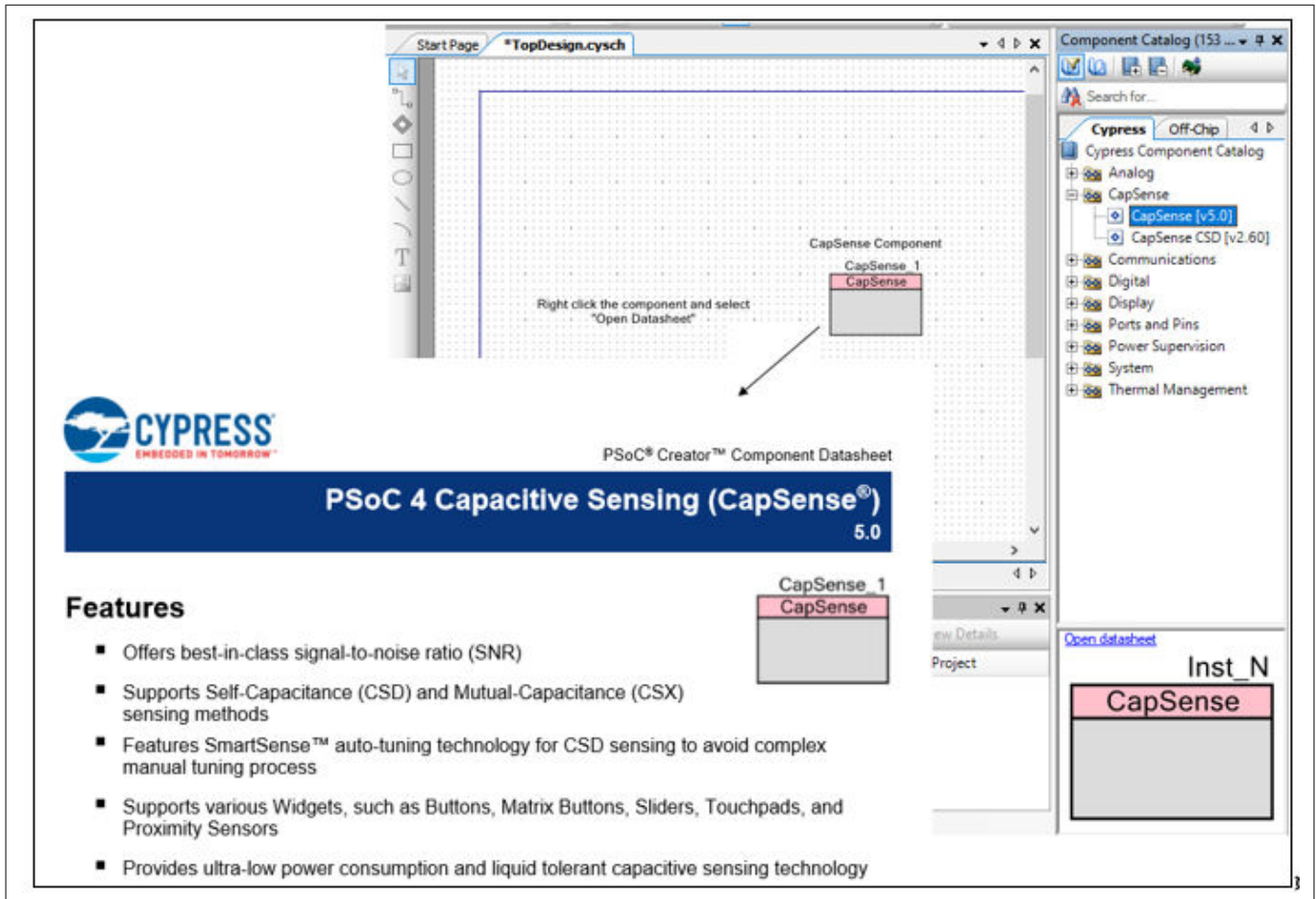

Figure 54 PSoC™ Creator component placement

Each CAPSENSE™ component has an associated datasheet that explains details about the Component. To open the Component datasheet, right-click the Component and select **Open Datasheet**.

The CAPSENSE™ component also has a Tuner GUI, called the [Tuner GUI](#), to help with the tuning process.

4.1.2 CapSense_ADC component

The CapSense_ADC⁵⁾ component is only applicable for the PSoC™ 4S-Series, PSoC™ 4100S Plus, PSoC™ 4100PS, and PSoC™ 6 MCU devices. This component should be used when both CAPSENSE™ and ADC operations are required. This component allows using the CAPSENSE™ block for ADC operation and touch functionality in a time-multiplexed manner.

4.1.3 Tuner GUI

Tuner helper is included with the CAPSENSE™ component and assists in tuning CAPSENSE™ parameters and monitoring sensor data such as raw count, baseline, and difference count. Refer the [Component datasheet/middleware document](#) for the detailed procedure on how to use Tuner GUI.

4.1.4 Example projects

You can use the CAPSENSE™ example projects provided in PSoC™ Creator to learn schematic entry and firmware development. To find a CAPSENSE™ example project, go to the [PSoC™ Creator home page](#), click **Find Code**

⁵ CapSense_ADC is not supported in devices with fifth-generation CAPSENSE™ block.

4 CAPSENSE™ design and development tools

Example ..., and select the appropriate architecture, as [Figure 55](#) shows. You can also filter for a project by writing partial or complete project name in the **Filter by** field.

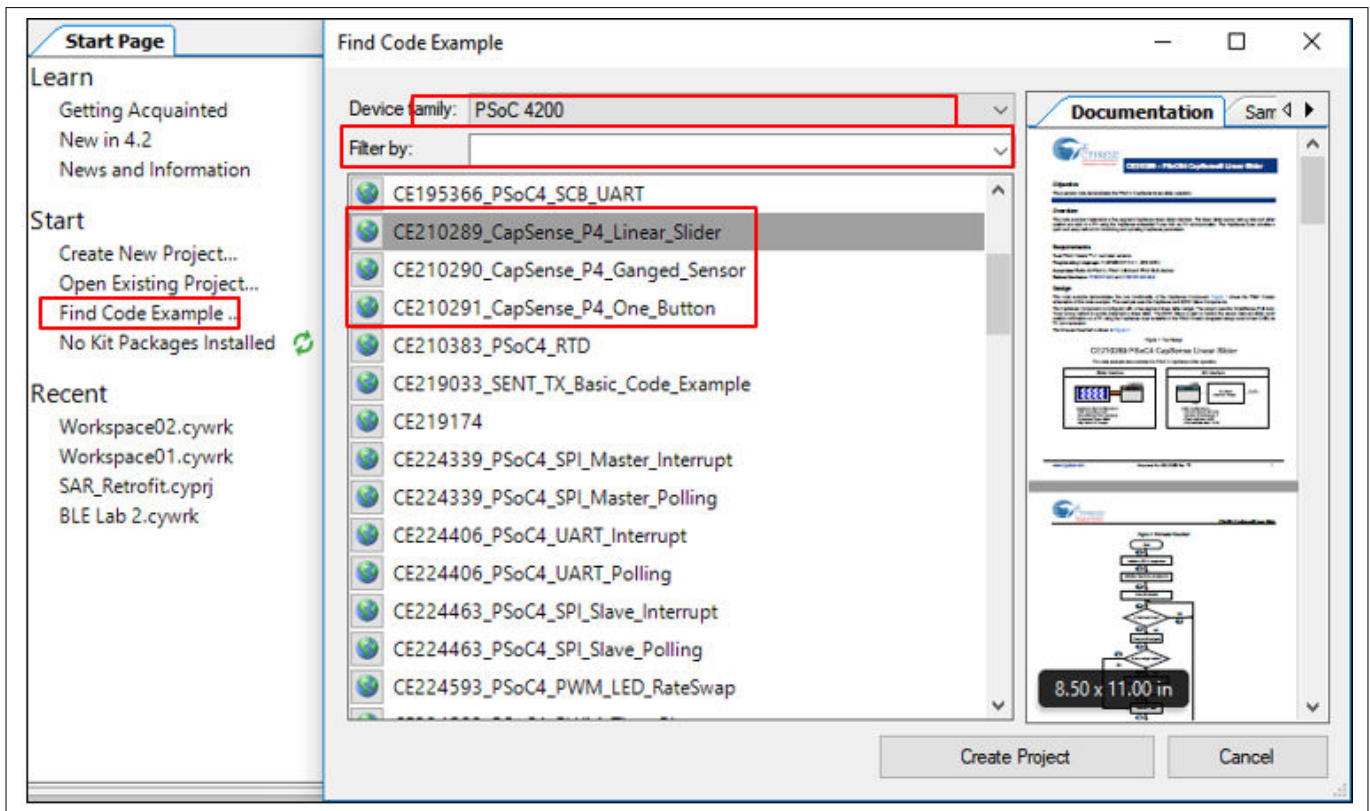

Figure 55 PSoC™ Creator example project

4.2 ModusToolbox™

ModusToolbox™ software suite is used for the development of PSoC™ 6 and PSoC™ 4⁶⁾ based CAPSENSE™ applications. You can download ModusToolbox™ from [here](#). Before you start working with this software, it is recommended that you go through the [Quick start guide](#) and [user guide](#). ModusToolbox™ software trainings can be found [here](#). If you have ModusToolbox™ IDE installed in your system, you can create a CAPSENSE™ application for the devices supported in ModusToolbox™.

4.2.1 CAPSENSE™ middleware

ModusToolbox™ provides a CAPSENSE™ middleware, which can be used to create a capacitive touch system in PSoC™ by simply configuring parameters in the CAPSENSE™ configuration tool. The middleware also provides an application programming interface (APIs) to simplify firmware development. See the [CAPSENSE™ middleware library](#) for more details.

4.2.2 CAPSENSE™ configurator

The CAPSENSE™ configurator tool in [ModusToolbox™](#) is similar to that in [PSoC™ Creator](#), which is used to configure the CAPSENSE™ hardware and software parameters. For more details on configuring CAPSENSE™ in ModusToolbox™, see the [ModusToolbox™ CAPSENSE™ configurator guide](#) and [CAPSENSE™ middleware library](#). [Figure 56](#) shows how to open the CAPSENSE™ configuration tool in ModusToolbox™. Alternatively, it can also be

⁶ See [Table 6](#) for supported PSoC™ 4 devices in ModusToolbox™.

4 CAPSENSE™ design and development tools

opened from the **Quick panel** in the ModusToolbox™. For simplicity of documentation, this design guide shows selecting the CAPSENSE™ parameter in PSoC™ Creator CAPSENSE™ component.

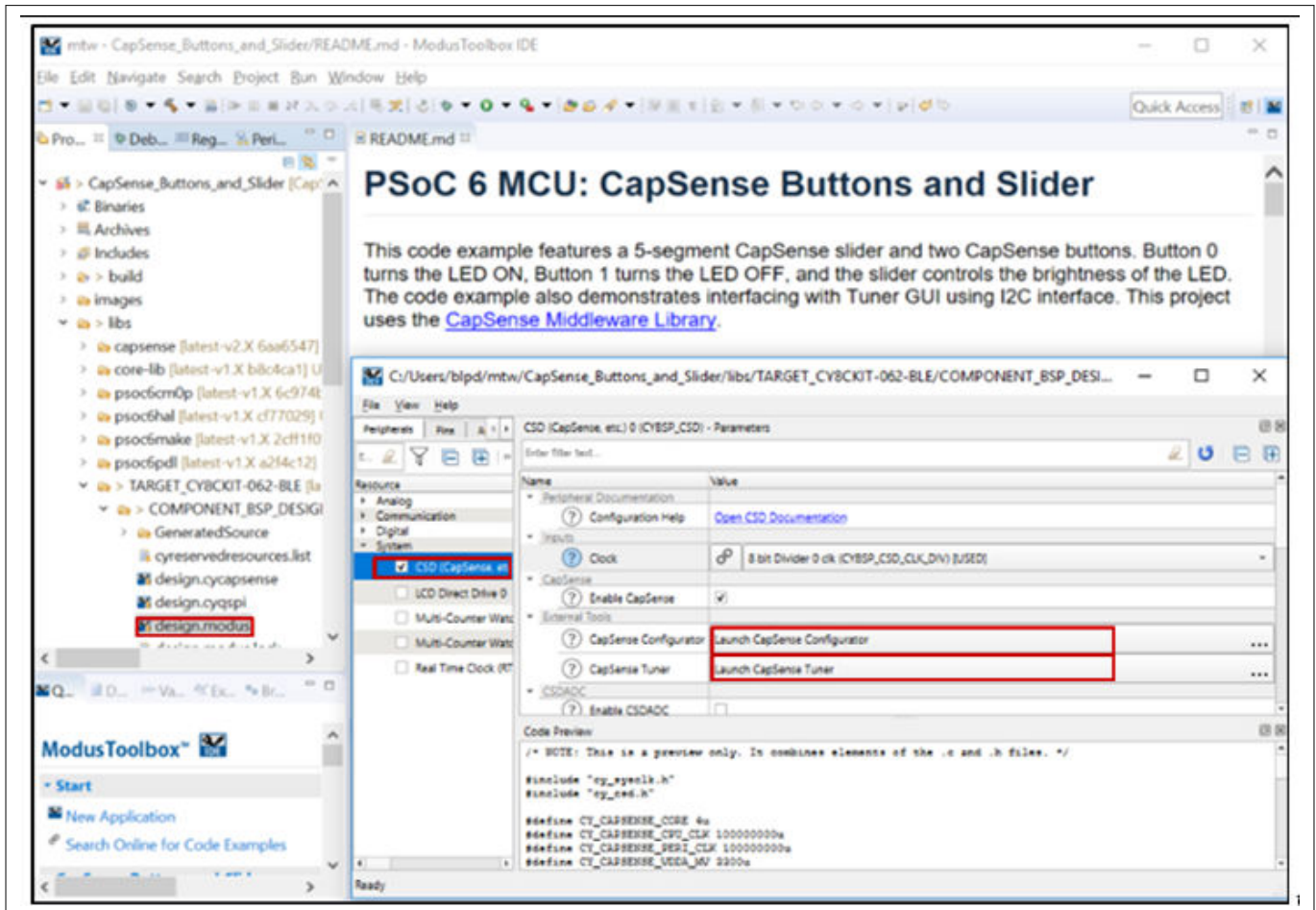

Figure 56 CAPSENSE™ configurator tool in ModusToolbox™

4.2.3 CSDADC middleware

This CSDADC middleware⁷⁾ should be used when both the CAPSENSE™ and ADC operations are required. This middleware allows using the CAPSENSE™ hardware block for ADC operation and touch functionality in a time-multiplexed manner. It could be used for all three sensing modes that is, CSD, ADC, and CSX. See the [CSDADC middleware library](#) documentation for more details.

4.2.4 CSDIDAC middleware

The CSDIDAC middleware allows you to use the CAPSENSE™ IDAC in a standalone mode. You can use this middleware if you are not using CAPSENSE™ middleware or if you are using only one IDAC for CAPSENSE™. See the [CSDADC middleware library](#) documentation.

4.2.5 CAPSENSE™ Tuner

ModusToolbox™ also supports a GUI tool that can be used for tuning CAPSENSE™ parameters. This tool can be opened from the [Device configurator](#) by selecting Launch CAPSENSE™ Tuner as shown in [Figure 56](#). See the [CAPSENSE™ tuner guide](#) documentation.

⁷⁾ CapSense_ADC is not supported in devices with the fifth-generation CAPSENSE™ block.

4 CAPSENSE™ design and development tools

4.2.6 Example projects

To quickly start the CAPSENSE™ system design, start with the example projects provided in ModusToolbox™. You can find a CAPSENSE™ example project by navigating to **File > New > ModusToolbox Application**. Choose the appropriate Board Support Package with a device. [Figure 57](#) shows creating a CAPSENSE™ CSD Button example starter code in ModusToolbox™ from the list of available code examples.

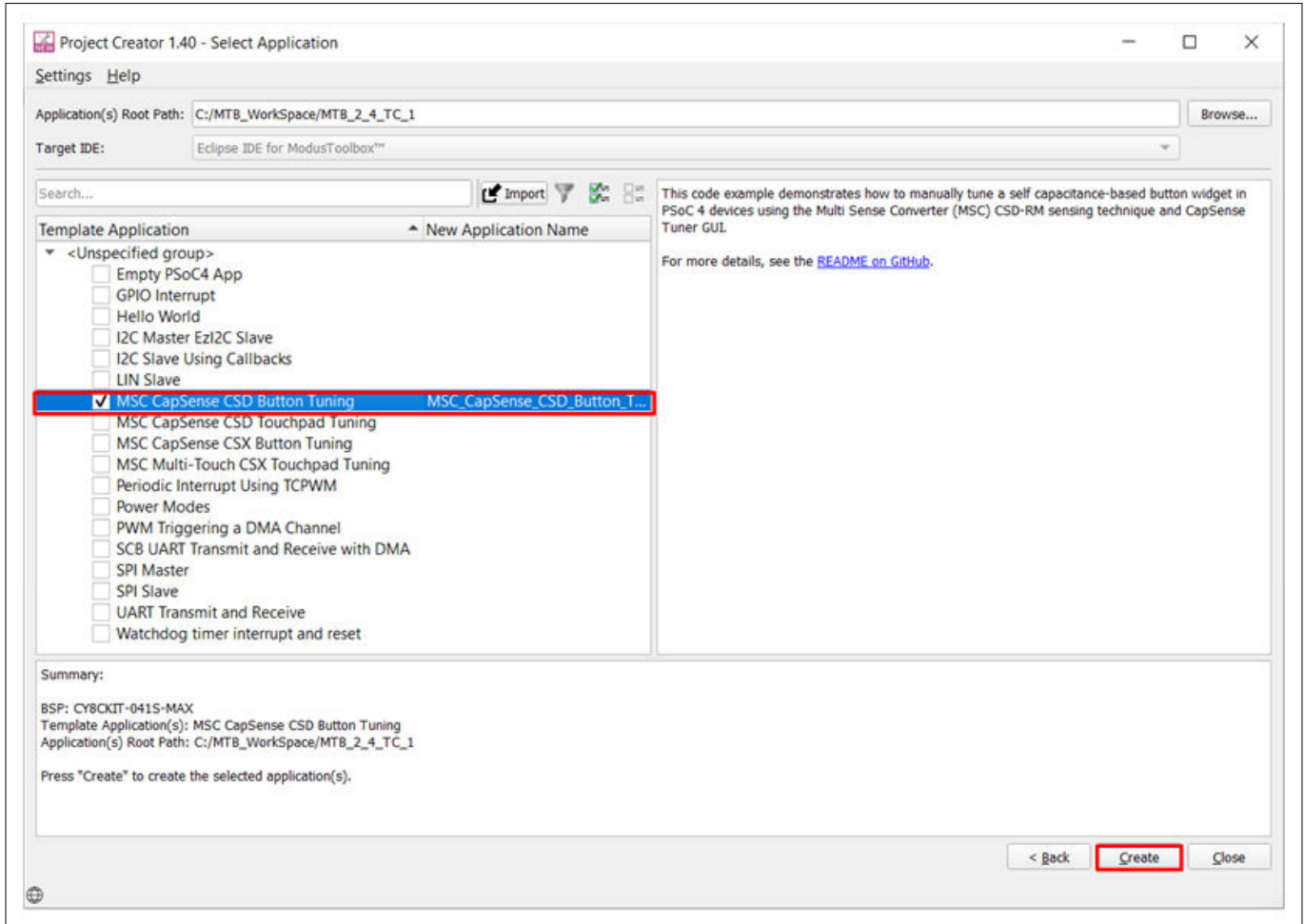

Figure 57 Creating CAPSENSE™ CSD Button example project in ModusToolbox™

4.3 Hardware kits

[Table 7](#) lists the development kits that support evaluation of PSoC™ 4 and PSoC™ 6 CAPSENSE™.

Table 7 PSoC™ 4 and PSoC™ 6 CAPSENSE™ development kits

Development kit	Supported CAPSENSE™ features
PSoC™ 4000 pioneer kit (CY8CKIT-040)	A 5x6 CAPSENSE™ touchpad and a wire proximity sensor
PSoC™ 4 S-series pioneer kit (CY8CKIT-041)	Two self- or mutual-capacitive sensing buttons A 7x7 self- or mutual-capacitive sensing touchpad
PSoC™ 4 S-series prototyping kit (CY8CKIT-145)	Three self- or mutual-capacitive sensing buttons A five-segment self- or mutual-capacitive sensing linear slider

(table continues...)

4 CAPSENSE™ design and development tools

Table 7 (continued) PSoC™ 4 and PSoC™ 6 CAPSENSE™ development kits

Development kit	Supported CAPSENSE™ features
PSoC™ 4100S Plus prototyping kit (CY8CKIT-149)	Three self- or mutual-capacitive sensing buttons A six-segment self- or mutual-capacitive sensing linear slider
PSoC™ 4100S Max pioneer kit (CY8CKIT041S-Max)	Two self- or mutual-capacitive sensing buttons An eight-segment self- or mutual-capacitive sensing linear slider A 10x16 self- or mutual-capacitive sensing touchpad A proximity sensor loop
PSoC™ 4000T kit (CY8CKIT-040T)	One CAPSENSE™ button A 4x5 self- or mutual-capacitive sensing touchpad A proximity sensor loop
PSoC™ 4 pioneer kit (CY8CKIT042)	A five-segment linear slider
PSoC™ 4 Bluetooth® LE pioneer Kit (CY8CKIT-042-BLE)	A five-segment linear slider and a wire proximity sensor
PSoC™ 4200-M pioneer kit (CY8CKIT-044)	A five-element gesture detection and two proximity wire sensors
PSoC™ 4200-L pioneer kit (CY8CKIT-046)	A five-element gesture detection, two proximity wire sensors, and an eight-element radial slider
PSoC™ 4100PS prototyping kit (CY8CKIT-147)	No onboard CAPSENSE™ sensors. The kit can be used to connect external sensors to any I/O pin.
CAPSENSE™ proximity shield (CY8CKIT-024)	A four-element gesture detection and one proximity loop sensor
CAPSENSE™ liquid level sensing shield (CY8CKIT-022)	A two-element flexible PCB and 12-element flexible PCB
PSoC™ 4 processor module (CY8CKIT038), with PSoC™ development kit (CY8CKIT001)	A five-segment linear slider and two buttons
CAPSENSE™ expansion board kit (CY8CKIT-031), to be used with CY8CKIT038 and CY8CKIT-001	A 10-segment slider, five buttons and a 4 x 4 matrix button with LED indication.
MiniProg3 program and debug kit (CY8CKIT-002)	CAPSENSE™ performance tuning in CY8CKIT-038
PSoC™ 6 Wi-Fi BT pioneer kit (CY8CKIT-062-WiFi-BT pioneer kit) and PSoC™ 6 Bluetooth® LE pioneer kit (CY8CKIT062-BLE pioneer kit)	A 5-segment CAPSENSE™ slider, two CAPSENSE™ buttons, one CAPSENSE™ proximity sensing header, a proximity sensor.
PSoC™ 6 Wi-Fi BT prototyping kit (CY8CPROTO-063-4343W)	A 5-segment CAPSENSE™ slider and two mutual-cap CAPSENSE™ buttons

5 CAPSENSE™ performance tuning

5 CAPSENSE™ performance tuning

After you have completed the sensor layout (see [PCB layout guidelines](#)), the next step is to implement the firmware and tune the CAPSENSE™ parameters for the sensor to achieve optimum performance. The CAPSENSE™ sensing method is a combination of hardware and firmware techniques. Therefore, it has several hardware and firmware parameters required for proper operation. These parameters should be tuned to optimum values for reliable touch detection and fast response. Most of the capacitive touch solutions in the market must be manually tuned. A unique feature called SmartSense (also known as Auto-tuning) is available for PSoC™ 4 and PSoC™ 6 CAPSENSE™. SmartSense is a firmware algorithm that automatically sets all parameters to optimum values.

5.1 Selecting between SmartSense and manual tuning

SmartSense auto-tuning reduces design cycle time and provides stable performance across PCB variations, but requires additional RAM and CPU resources, as indicated in the [Component datasheet/middleware](#) document or [ModusToolbox™ CAPSENSE™ configurator guide](#), to allow runtime tuning of CAPSENSE™ parameters. SmartSense is recommended mainly for conventional CAPSENSE™ applications involving simple button and slider widgets, and is currently supported only for [Self-capacitance sensing](#) and not [Mutual-capacitance sensing](#).

On the other hand, manual tuning requires effort to tune optimum CAPSENSE™ parameters, but allows strict control over characteristics of capacitive sensing system, such as response time and power consumption. It also allows use of CAPSENSE™ beyond the conventional button and slider applications such as proximity and liquid-level-sensing.

SmartSense is the recommended tuning method for all the conventional CAPSENSE™ applications. You should use SmartSense auto-tuning if your design meets the following requirements:

- The design is for conventional user-interface application like buttons, sliders, and touchpad
- The parasitic capacitance (C_p) of the sensors is within SmartSense-supported range as mentioned in the “SmartSense operating conditions” section in [Component datasheet/middleware document](#) or [ModusToolbox™ CAPSENSE™ configurator guide](#)
- The sensor scan time chosen by SmartSense meets the response time/power requirements of the end system
- SmartSense auto-tuning meets the RAM/flash requirements of the design

For all other applications, use [Manual tuning](#). In such cases, you can also use SmartSense as an initial step to find the optimum hardware parameters such as Sense Clock frequency, and then change the tuning mode to manual tuning for further tuning of the CAPSENSE™ parameters. See [Using SmartSense to determine hardware parameters](#).

Note: Manual tuning requires I²C or UART communication with a host PC.

5.2 SmartSense

5.2.1 Overview

The CAPSENSE™ algorithm is a combination of hardware and firmware blocks inside PSoC™. Therefore, it has several hardware and firmware parameters required for proper operation. These parameters need to be tuned to optimum values for reliable touch detection and fast response.

SmartSense is a CAPSENSE™ tuning method that automatically sets sensing parameters for optimal performance, based on user-specified finger capacitance values, and continuously compensates for system, manufacturing, and environmental changes.

5 CAPSENSE™ performance tuning

Note: SmartSense currently supports widgets with **CSD (Self-cap)** Sensing mode only. **CSX (Mutual-cap)** widgets must be tuned manually.

Some advantages of SmartSense, as opposed to manual tuning are:

- **Reduced design cycle time:** The design flow for capacitive touch applications involves tuning all of the sensors. This step can be time consuming if there are many sensors in your design. In addition, you must repeat the tuning when there is a change in the design, PCB layout, or mechanical design. Auto-tuning solves these problems by setting all of the parameters automatically. Figure 58 shows the design flow for a typical CAPSENSE™ application with and without SmartSense

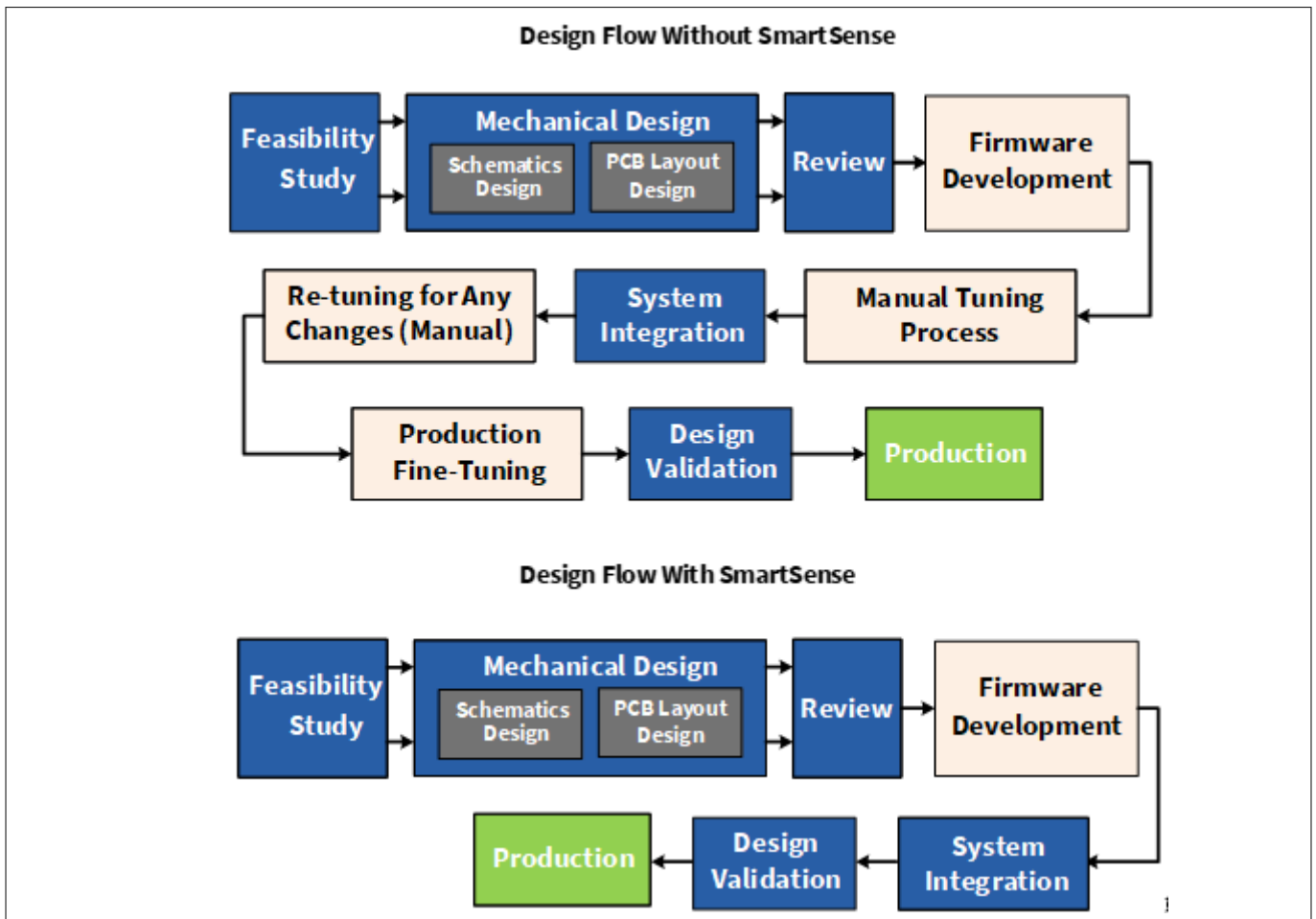

Figure 58 Design flow with and without SmartSense

- **Performance is independent of PCB variations:** The parasitic capacitance, C_p , of individual sensors can vary due to process variations in PCB manufacturing, or vendor-to-vendor variation in a multi-sourced supply chain. If there is significant variation in C_p across product batches, the CAPSENSE™ parameters must be re-tuned for each batch. SmartSense sets parameters for each device automatically, hence taking care of variations in C_p
- **Ease of use:** SmartSense is faster and easier to use because only a basic knowledge of CAPSENSE™ is needed

Note that SmartSense can be used in multiple ways:

1. SmartSense (Full auto-tune) – This is the quickest way to tune. This method calibrates CAPSENSE™ hardware and software parameters automatically at runtime. This is the recommended method for most designs
2. SmartSense (Hardware parameters only) – This method auto-tunes all hardware parameters of CAPSENSE™, but allows to set user-defined threshold values (see Table 13). This method consumes less

5 CAPSENSE™ performance tuning

flash/RAM resources than SmartSense (Full Auto-Tune). Also, this method avoids the extra processing needed for automatic threshold calculation and hence allows lower power consumption for a given scan rate. Use this method for low-power or noisy designs or in cases with constrained memory requirements

- 3. SmartSense for initial tuning – You may also use SmartSense for initial tuning, to quickly find the best settings for a CAPSENSE™ board and then change to manual tuning. This method is useful for cases with strict requirements on response time or power consumption. This is a quick method to find the best settings, instead of starting manual tuning from scratch. Refer to the section [Using SmartSense to determine hardware parameters](#) for more details

4. **Table 8 CAPSENSE™ parameters auto-tuned in SmartSense**

Parameter	Full auto-tune mode	Hardware parameters only mode
Scan resolution	Calculated once on CAPSENSE™ initialization.	
Compensation IDAC		
Modulator IDAC		
Sense clock frequency		
Modulator clock frequency		
Finger threshold	Calculated once on CAPSENSE™ initialization based on the selected finger capacitance and updated after each sensor scan.	Manual selection (see Table 13).
Noise threshold		
Hysteresis		
Negative noise threshold		
Low baseline reset		

5.2.2 SmartSense full auto-tune

In SmartSense Full Auto-tune mode, the only parameter that needs to be tuned by the user is the Finger Capacitance parameter. The Finger Capacitance parameter (C_F) indicates the minimum value of finger capacitance that should be detected as a valid touch by the CAPSENSE™ Component. Whenever the actual C_F that is added when the finger touches the button sensor is greater than the value specified for the Finger Capacitance parameter in the Component configuration window, the sensor status will change to ‘1’; however, if the actual C_F added by the finger touch is less than the value specified in the Component configuration window, the sensor status will remain ‘0’. The way of tuning the finger capacitance is different for button and slider widgets.

Note: Even for SmartSense auto-tuning, the CAPSENSE™ Component allows manual configuration of some general parameters like enable/disable of compensation IDAC, filters, shield such as liquid-tolerance-related parameters and modulator clock. These can be left at their default values for most cases or configured based on the respective sections in this guide.

5.2.2.1 Tuning button widgets

This section explains how to choose the Finger capacitance value for the Button widget. You may perform only a coarse tuning of the Finger capacitance parameter for a working design, or you may choose to fine-tune the Finger capacitance value. Coarse-tuning will satisfy the requirements of most designs, but fine-tuning will allow you to choose the most efficient CAPSENSE™ parameters (that is, minimum sensor scan time) using SmartSense.

If you do not know the value of C_F (C_F can be estimated based on [Equation 1](#)), set the Finger capacitance as follows:

5 CAPSENSE™ performance tuning

1. Start by specifying the highest value for finger capacitance (from the available options in the list) and check the SNR and button status when the button is touched. Use the [Tuner GUI](#) to find the SNR
2. Decrease the finger capacitance parameter value until the button status changes to '1' on touch and SNR>5. [Figure 59](#) shows the detailed steps to find the right value for the Finger capacitance parameter in your design

Enable filters if the SNR of one or more sensors is less than 5:1 when the set finger capacitance is already at the least finger capacitance supported in the Component. You can also enable filters if externally induced noise is causing a decrease in SNR. See [Table 9](#) to choose the right filter in this case. There are various types of filters available in the CAPSENSE™ Component such as Median Filter, IIR filter, and Average Filter; you can enable more than one filter to reduce the noise in the raw count according to the requirement.

If you choose to use an IIR filter, begin by selecting a filter with a higher value of the filter coefficient and keep decreasing it until you achieve an SNR greater than or equal to 5:1. Using filters will affect the response time. You must properly select the filter coefficient such that the response time and SNR requirement are satisfied.

If the SNR is still less than 5:1 even when the smallest allowed value of finger capacitance and proper filter is chosen, see [PCB layout](#) , [Manual tuning](#), or [Tuning debug FAQs](#) for more details on debugging the issue.

5 CAPSENSE™ performance tuning

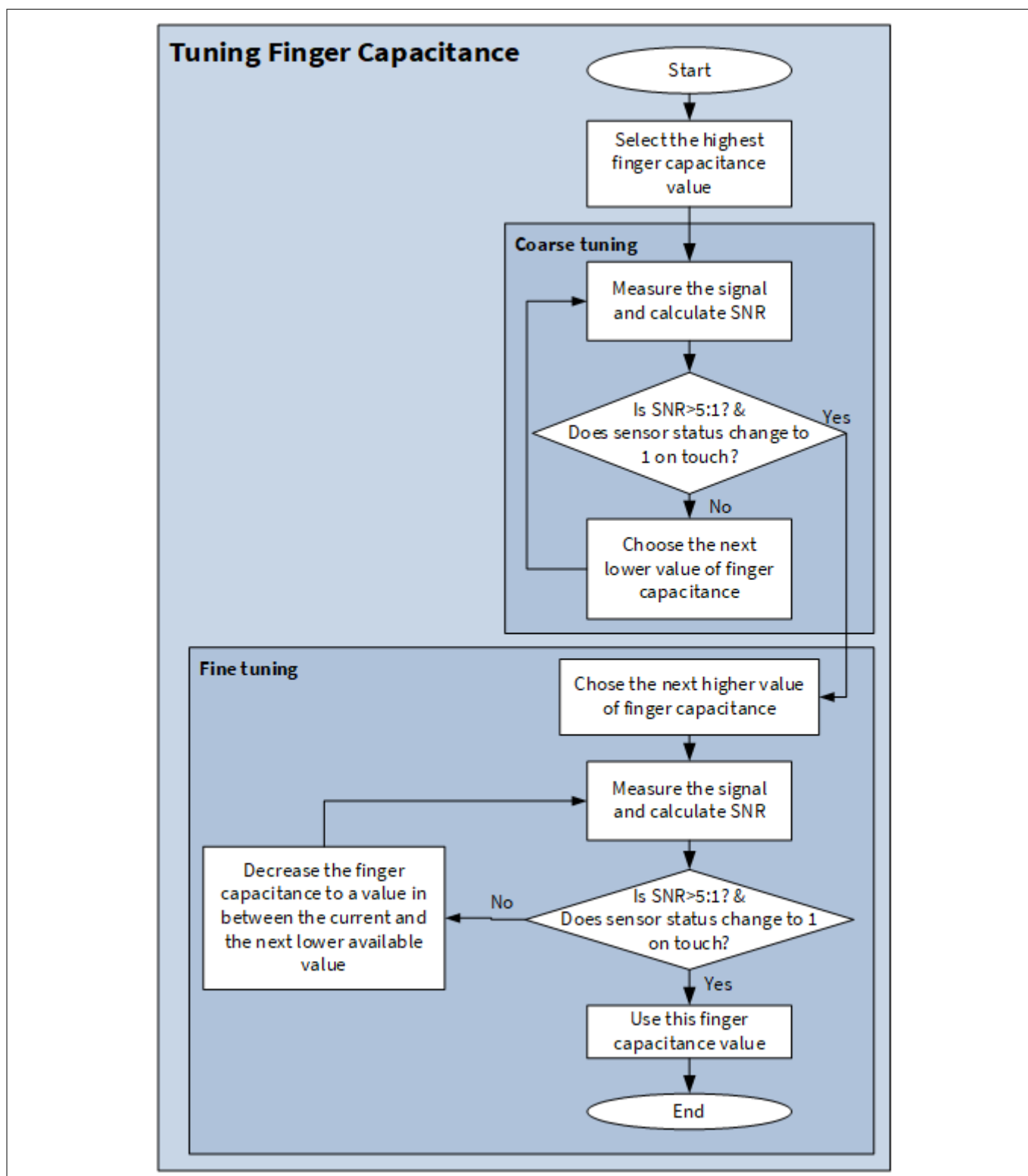

Figure 59 Using SmartSense auto-tuning based CAPSENSE™ project in PSoC™ Creator

5 CAPSENSE™ performance tuning

Table 9 Raw data noise filters in CAPSENSE™ component

Filter	Description	Mathematical description	Application
Median	Nonlinear filter that takes the three most recent samples and computes the median value.	$y[i] = \text{median}(x[i], x[i - 1], x[i - 2])$	Eliminates noise spikes from motors and switching power supplies
Average	Finite impulse response filter (no feedback) with equally weighted coefficients. It takes the four most recent samples and computes their average.	$y[i] = \frac{1}{4} \times (x[i] + x[i - 1] + x[i - 2] + x[i - 3])$	Eliminates periodic noise (for example, from power supplies)
First Order IIR	Infinite impulse response filter (feedback) with a step response similar to an RC low pass filter, thereby passing the low-frequency signals (finger touch responses). K value is fixed to 256. N is the IIR filter raw count coefficient. A lower N value results in lower noise, but slows down the response.	$y[i] = \frac{1}{K} \times \{N \times x[i] + (K - N) \times y[i - 1]\}$	Eliminates high frequency noise.

5.2.2.2 Tuning slider widgets

For sliders, set finger capacitance to the highest value initially. Slide your finger on the slider. If at any position on the slider, at least one slider segment status is ON and has an SNR >5:1, and at least two slider segments report a “difference count” that is, a “sensor signal” value greater than 0, use this finger capacitance value. Otherwise, decrease the finger capacitance value until the above condition holds true. [Figure 60](#) shows how to tune the finger capacitance for slider widget.

If these conditions are not met even after setting minimum allowed Finger Capacitance, use [Manual tuning](#) or revise the hardware according to [Slider design](#) considerations or see [Tuning debug FAQs](#). [Figure 60](#) explains the process of setting finger capacitance value for sliders.

Note: It is recommended to use the compensation IDAC because it allows a higher variation in the parasitic capacitance of the slider segment with respect to the slider segment that has the maximum C_p .

5 CAPSENSE™ performance tuning

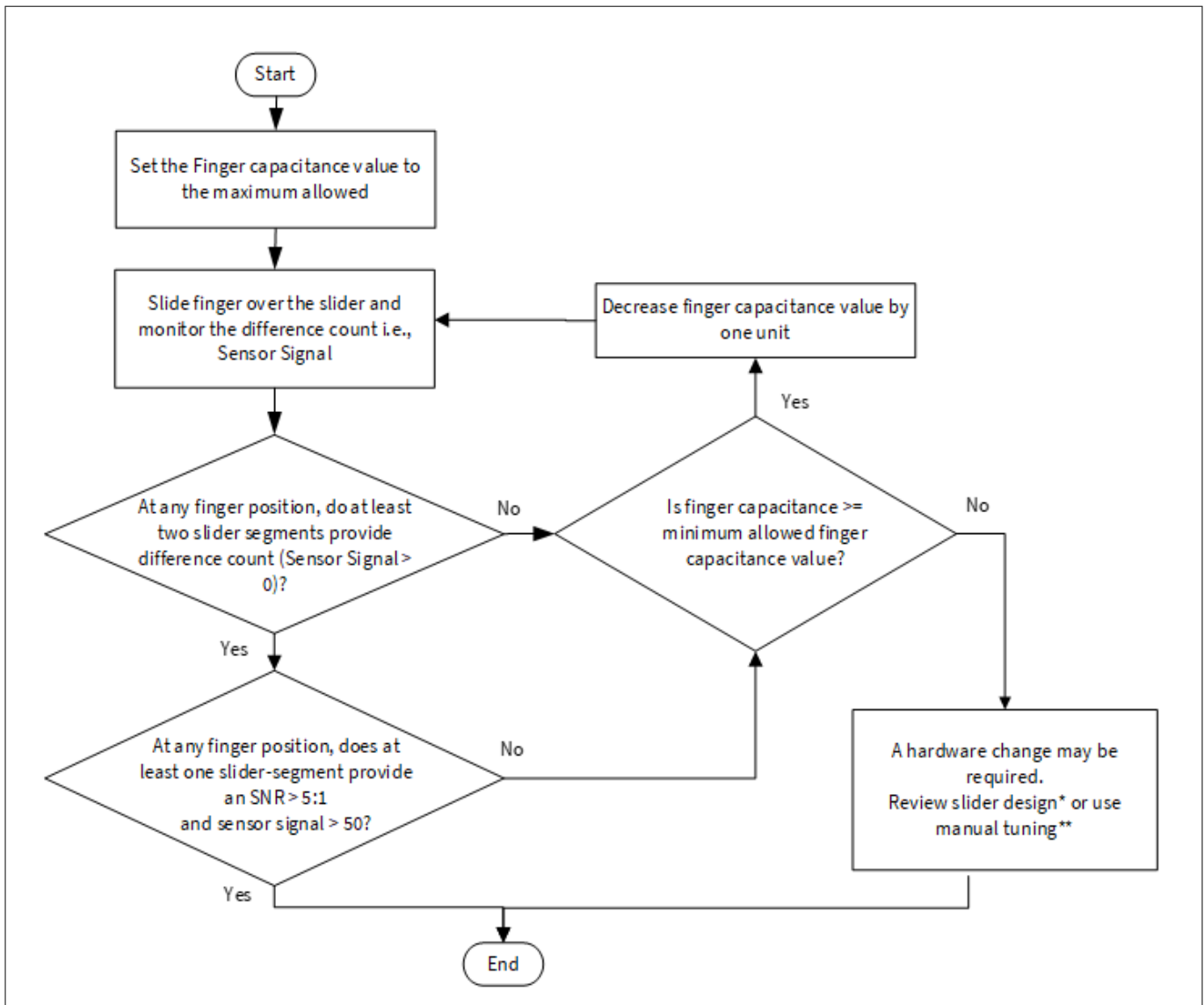

Figure 60 Setting finger capacitance value for sliders

* To review slider design, see the [Slider design](#) section in the [Design considerations](#) chapter.

** To do manual tuning, see the [Manual tuning](#) section in the [CAPSENSE™ performance tuning](#) chapter.

5.2.2.3 Tuning proximity widgets

See [AN92239 Proximity sensing with CAPSENSE™](#) and the “Proximity sensing” section in [Getting started with CAPSENSE™ design guide](#).

5.2.3 SmartSense hardware parameters-only mode

See [Table 13](#) for the recommended values for thresholds when the CSD tuning method is SmartSense (Hardware parameters only).

5.2.4 SmartSense for initial tuning

See [Using SmartSense to determine hardware parameters](#) for more details.

5 CAPSENSE™ performance tuning

5.3 Manual tuning

5.3.1 Overview

SmartSense technology allows a device to calibrate itself for optimal performance and complete the entire tuning process automatically. This technology will meet the needs of most designs, but in cases where SmartSense does not work or there are specific SNR or power requirements, the CAPSENSE™ parameters can be adjusted to meet system requirements. This can be achieved by manual tuning.

Some advantages of manual tuning, as opposed to [SmartSense](#) auto-tuning are:

- **Strict control over parameter settings:** SmartSense sets all the parameters automatically. However, there may be situations where you need to have strict control over the parameters. For example, use manual tuning if you need to strictly control the time PSoC™ takes to scan a group of sensors or strictly control the sense clock frequency of each sensor (this can be done to reduce EMI in systems)
- **Supports higher parasitic capacitances:** If the parasitic capacitance is higher than the value supported by SmartSense, you should use manual tuning. See the [Component datasheet/middleware document](#) for more details on the supported range of parasitic capacitance by SmartSense

The manual tuning process can be summarized in the following three steps and is shown in [Figure 61](#).

Set initial values of [Selecting CAPSENSE™ hardware parameters](#) using SmartSense (see [Using SmartSense to determine hardware parameters](#)) or determine the values manually.

Tune CAPSENSE™ component hardware parameters to ensure that [Signal-to-noise](#) is greater than 5:1 with a signal of at least 50 counts while meeting the system timing requirements.

Set optimum values of [Selecting CAPSENSE™ software parameters](#).

The following sections describe the fundamentals of manual tuning and the above three steps in detail. Knowledge of the CAPSENSE™ architecture in PSoC™ is a prerequisite for these sections. See [Capacitive touch sensing method](#) and [CAPSENSE™ generations in PSoC™ 4 and PSoC™ 6](#). The main difference in CAPSENSE™ architecture across different generations are listed in [Table 2](#).

Depending upon the sensing method selected, the manual tuning procedure will differ. See [CSD sensing method \(third- and fourth-generation\)](#), [CSX sensing method \(third- and fourth-generation\)](#) chapter for their respective manual tuning procedures. You can skip these sections if you are not planning to use manual tuning in your design. [Figure 61](#) shows a general manual tuning procedure.

5 CAPSENSE™ performance tuning

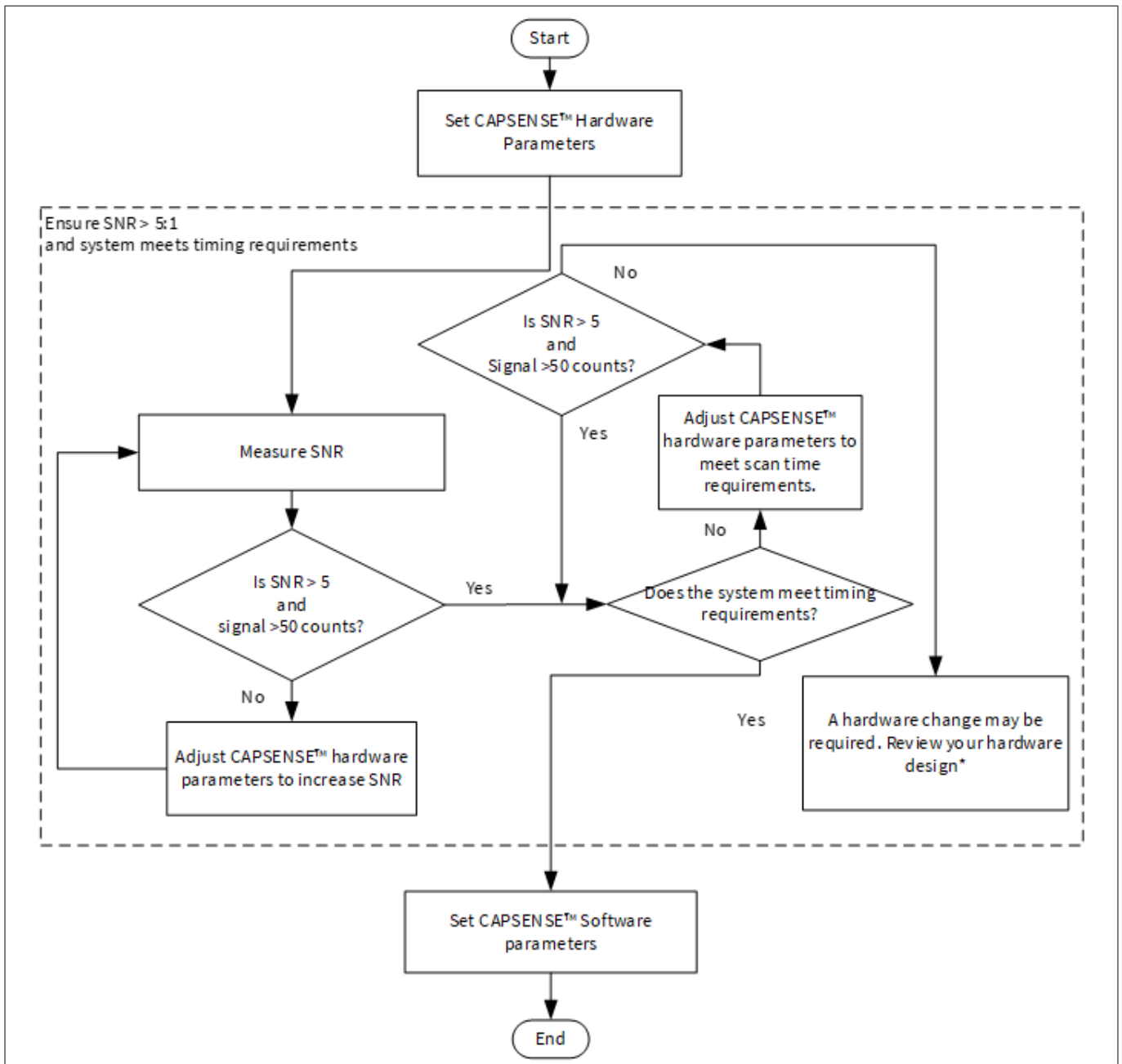

Figure 61 Manual tuning process overview

* To review the hardware design, see the [Sensor construction](#) and [PCB layout guidelines](#) sections in the [Design considerations](#) chapter.

5.3.2 CSD sensing method (third- and fourth-generation)

This section explains the basics of manual tuning using CSD sensing method. It also explains the hardware and software parameters that influence CSD sensing method and procedure of manual tuning for button, slider, touchpad and proximity widgets.

5 CAPSENSE™ performance tuning

5.3.2.1 Basics

5.3.2.1.1 Conversion gain and CAPSENSE™ signal

Conversion gain will influence how much signal the system sees for a finger touch on the sensor. If there is more gain, the signal is higher, and a higher signal means a higher achievable [Signal-to-noise ratio \(SNR\)](#).

Note: An increased gain may result in an increase in both signal and noise. However, if required, you can use firmware filters to decrease noise. For details on available firmware filters, see [Table 9](#).

Conversion gain in single IDAC mode

In the [single IDAC mode](#), the raw count is directly proportional to the sensor capacitance.

$$\text{rawcount} = G_{CSD} C_S$$

Equation 30 Raw count relationship to sensor capacitance

Where,

C_S = sensor capacitance

$C_S = C_P$ if there is no finger present on sensor

$C_S = (C_P + C_F)$ when there is a finger present on the sensor

G_{CSD} = Capacitance to digital conversion gain of CAPSENSE™ CSD

The approximate value of this conversion gain using the IDAC sourcing mode, according to [Equation 10](#) and [Equation 30](#) is:

$$G_{CSD} = (2^N - 1) \frac{V_{REF} F_{SW}}{I_{MOD}}$$

Equation 31 Capacitance to digital converter gain

$$G_{CSD} = (2^N - 1) \frac{(V_{DD} - V_{REF}) F_{SW}}{I_{MOD}}$$

Equation 32 Capacitance to digital converter gain (sinking IDAC mode)

Where,

V_{REF} = Comparator reference voltage. Refer [Table 2](#).

F_{SW} = Sense clock frequency

I_{MOD} = Modulator IDAC current

N = Resolution of the sigma to delta converter.

The tunable parameters of the conversion gain are V_{REF} , F_{SW} , I_{MOD} , and N. [Figure 62](#) illustrates a plot of raw count versus sensor capacitance.

5 CAPSENSE™ performance tuning

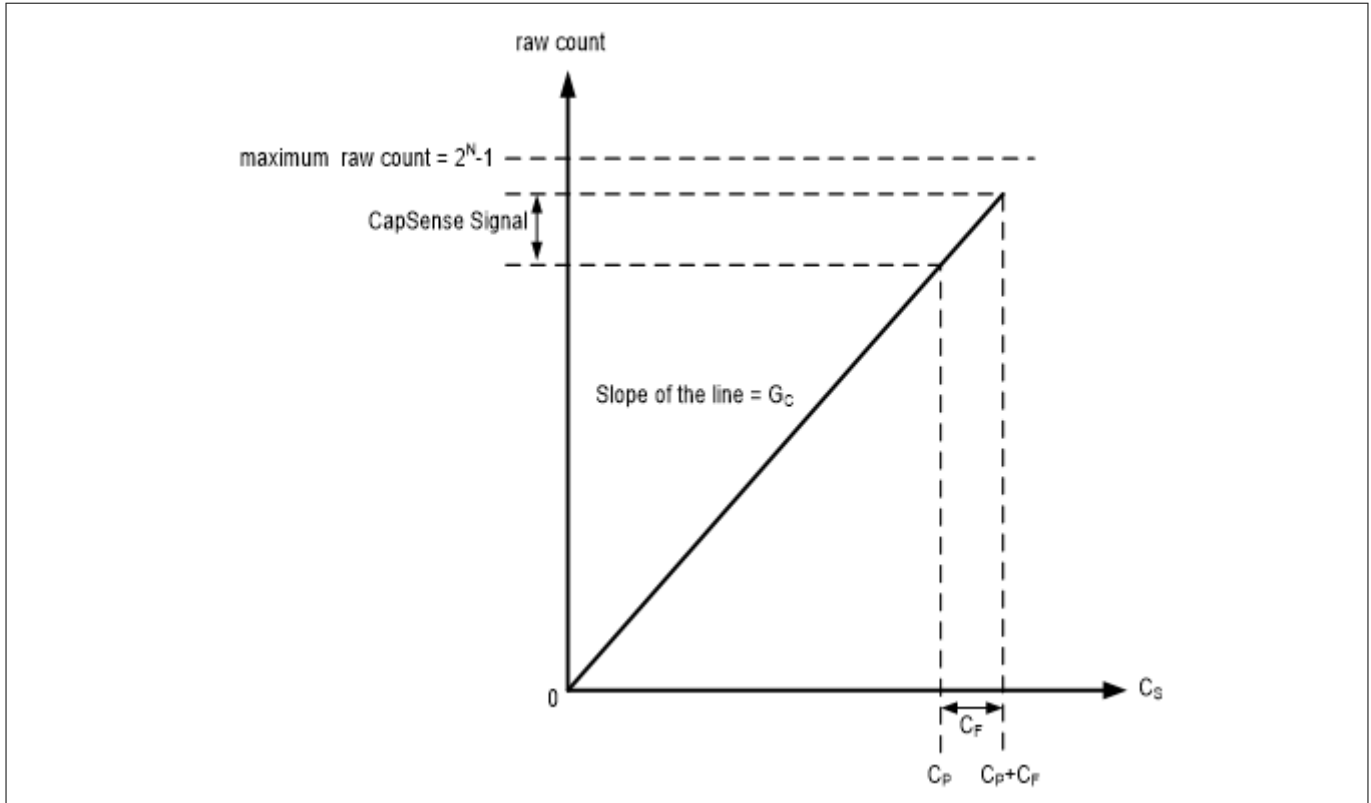

Figure 62 Raw count versus sensor capacitance

The change in raw counts when a finger is placed on the sensor is called CAPSENSE™ signal. Figure 63 shows how the value of the signal changes with respect to the conversion gain.

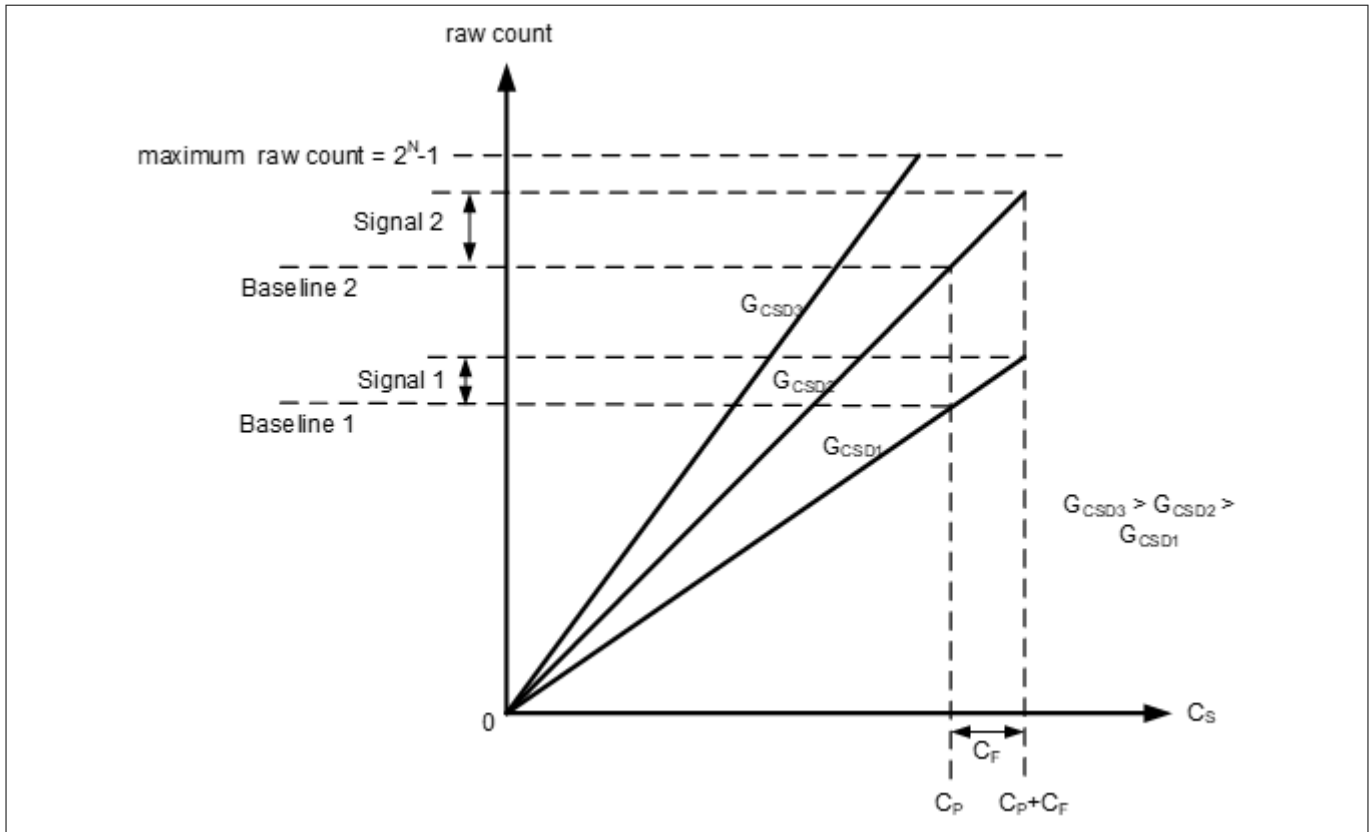

Figure 63 Signal values for different conversion gains

5 CAPSENSE™ performance tuning

Figure 63 shows three plots corresponding to three conversion gain values G_{CSD3} , G_{CSD2} , and G_{CSD1} . An increase in the conversion gain results in higher signal value. However, this increase in the conversion gain also moves the raw count corresponding to C_P (that is, Baseline) towards the maximum value of raw count (2^N-1). For very high gain values, the raw count saturates as the plot of G_{CSD3} shows. Therefore, you should tune the conversion gain to get a good signal value while avoiding saturation of raw count. Tune the CSD parameters such that when there is no finger on the sensor, that is when $C_S = C_P$, the raw count = 85% of (2^N-1) as Figure 64 shows. This ensures maximum gain, with enough margin for the raw count to grow because of environmental changes, and not saturate on finger touches.

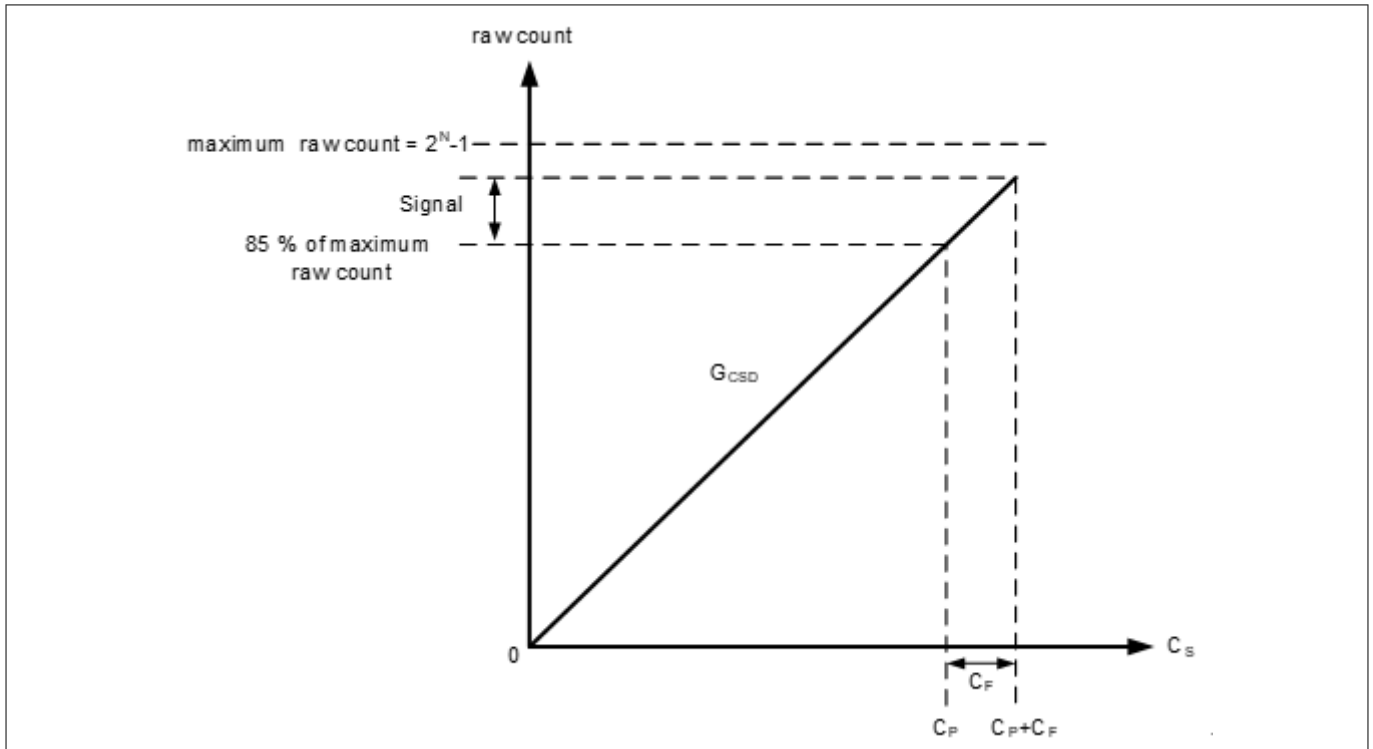

Figure 64 Recommended tuning

Conversion gain in dual IDAC mode

The equation for raw count in the dual IDAC mode, according to Equation 30 and Equation 12 is:

$$\text{rawcount} = G_{CSD}C_S - \left(2^N - 1\right) \frac{I_{COMP}}{I_{MOD}}$$

Equation 33 Dual IDAC mode raw counts

Where,

I_{COMP} = Compensation IDAC current

G_{CSD} is given by Equation 9 for sourcing IDAC mode and Equation 32 for sinking IDAC mode.

In both single IDAC and dual IDAC mode, tune the CSD parameters, so that when there is no finger on the sensor, that is when $C_S = C_P$ the raw count = 85% of (2^N-1), as Figure 65 shows, to ensure high conversion gain, to avoid Flat-spots, and to avoid raw count saturation due to environmental changes.

5 CAPSENSE™ performance tuning

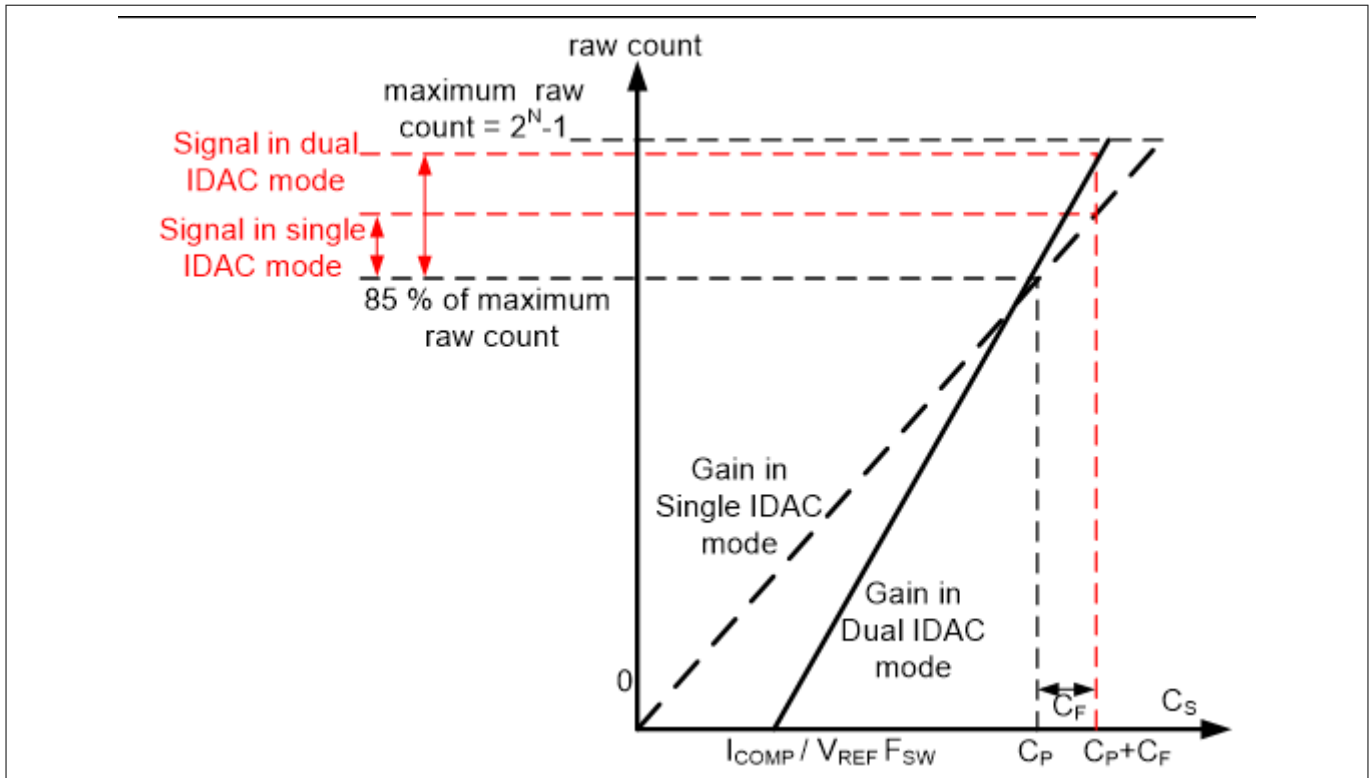

Figure 65 Recommended tuning in dual IDAC mode

As Figure 65 shows, the 85% requirement restricts to a fixed gain in single-IDAC mode, while in dual-IDAC mode, gain can be increased by moving the C_S axis intercept to the right (by increasing I_{COMP}) and correspondingly decreasing the modulator IDAC (I_{MOD}) to still achieve raw count = 85% of $(2^N - 1)$ for $C_S = C_P$. Using dual IDAC mode this way brings the following changes to the Raw Count versus C_P graph:

1. Use of compensation IDAC introduces a non-zero intercept on the C_S axis as given in .

$$C_S \text{ axis intercept} = \left(\frac{I_{COMP}}{V_{REF} F_{SW}} \right)$$

Equation 34 C_S axis intercept with regards to I_{COMP}

The value of I_{MOD} in the dual IDAC mode is half compared to the value of I_{MOD} in the single IDAC mode (all other parameters remaining the same), so the gain G_{CSD} in the dual IDAC mode is double the gain in the single IDAC mode according to [dual IDAC mode](#). Thus, the signal in the dual IDAC mode is double the signal in the single IDAC mode for a given resolution N.

While manually tuning a sensor, keep [dual IDAC mode](#) and [Equation 23](#) as well as the following points in mind:

1. Higher gain leads to increased sensitivity and better overall system performance. However, do not set the gain such that raw counts saturate, as the plot of gain G_{CSD3} shows in [Figure 63](#). It is recommended to set the gain in such a way that the raw count corresponding to C_P is 85 percent of the maximum raw count for both the single IDAC and dual IDAC mode. The sense clock frequency (F_{SW}) should be set carefully; higher the frequency, higher the gain, but the frequency needs to be low enough to fully charge and discharge the sensor as [Equation 23](#) indicates
2. Enabling the Compensation IDAC plays a huge role in increasing the gain; it will double the gain if set as recommended [above](#). Always enable the Compensation IDAC when it is not being used for general-purpose applications

5 CAPSENSE™ performance tuning

3. Lower the modulation IDAC current, higher the gain. Adjust your IDAC to achieve the highest gain, but make sure that the raw counts corresponding to C_p have enough margin for environmental changes such as temperature shifts, as indicated in [Figure 64](#) and [Figure 65](#)
4. Increasing the number of bits of resolution used for scanning increases gain. An increase in resolution by one bit will double the gain of the system, but also double the scan time according to [Equation 8](#). A balance of scan time and gain needs to be achieved using resolution

5.3.2.1.2 Flat-spots

Ideally, raw counts should have a linear relationship with sensor capacitance as [Figure 62](#) and [Figure 65](#) show. However, in practice, sigma delta modulators have non-sensitivity zones, also called flat-spots or dead-zones – for a range of sensor capacitance values, the sigma delta modulator may produce the same raw count value as [Figure 66](#) shows. This range is known as a dead-zone or a flat-spot.

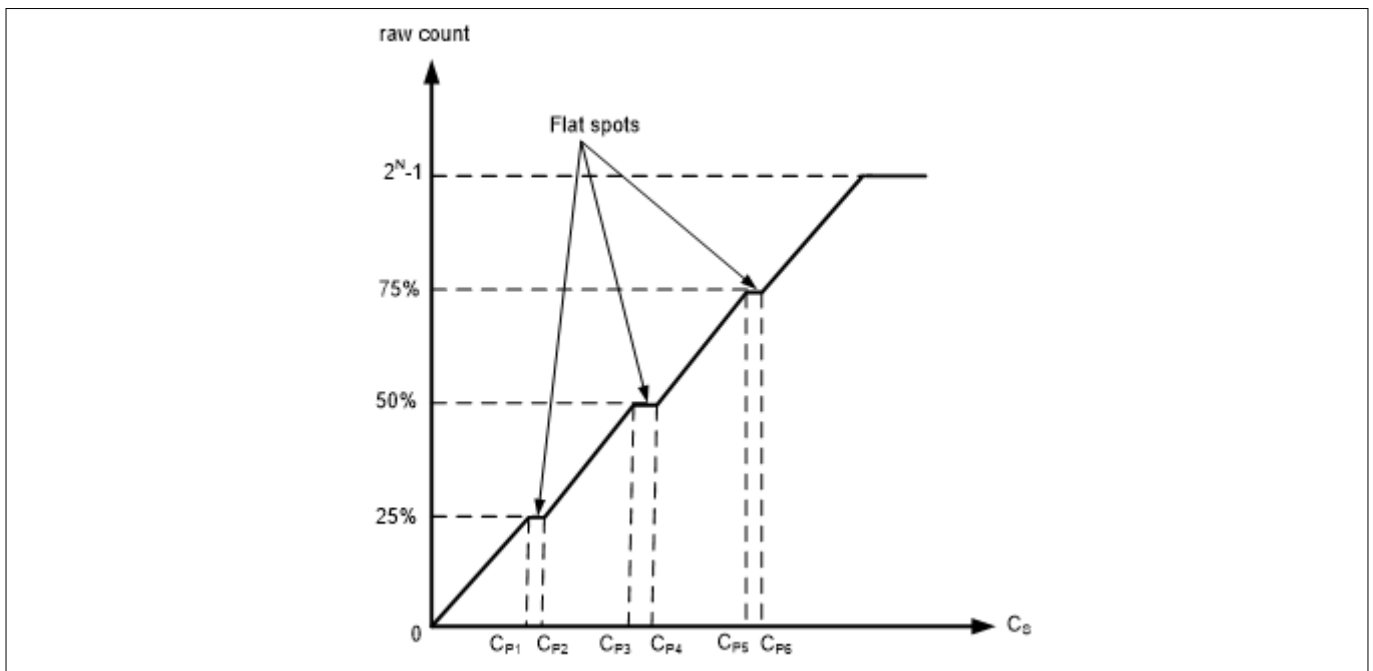

Figure 66 Flat-spots in raw counts versus sensor capacitance when direct clock is used

In the case of CAPSENSE™ CSD, these flat spots occur near 25, 50, and 75 percent of the maximum raw count value (that is, near 25%, 50%, and 75% of 2^N-1 , where $N = \text{Scan resolution}$). These flat spots are prominent when direct clock is used as [Sense Clock](#) source. Flat-spots do not occur if PRS is used as the Sense Clock source (see also section [Using SmartSense to determine hardware parameters](#)).

For almost all systems, we recommend using PRS as the Sense Clock source because it limits the impact of flat spots and also provides EMI/EMC benefits as indicated in [Sense Clock](#). If your system requires a direct clock, ensure that you use [auto-calibration](#) or avoid this raw count range when using manual calibration.

Flat-spots reduction techniques

1. Calibrate rawcount to 85%
 In the case of CAPSENSE™ CSD, these flat-spots occur near 25, 50, and 75 percent of the maximum raw count value (that is, near 25%, 50%, and 75% of 2^N-1 , where ‘N’ is the Scan resolution). Setting calibration to 85% decrease the width of flat-spots significantly.
2. Use PRS clock
 These flat-spots are prominent when direct clock is used as [Sense Clock](#) source. Flat-spots do not occur if PRS is used as the Sense Clock source (see also section [Using SmartSense to determine hardware](#)

5 CAPSENSE™ performance tuning

[parameters](#) .For almost all systems, we recommend using PRS as the Sense Clock source because it limits the impact of flat-spots and also provides EMI/EMC benefits as indicated in [Sense clock source](#) Sense clock . If your system requires a direct clock, ensure that you use [auto-calibration](#) or avoid this raw count range when using manual calibration.

5.3.2.2 Selecting CAPSENSE™ hardware parameters

CAPSENSE™ hardware parameters govern the conversion gain and CAPSENSE™ signal. [Table 10](#) lists the CAPSENSE™ hardware parameters that apply to CSD sensing method. The following subsection gives guidance on how to adjust these parameters to achieve optimal performance for CAPSENSE™ CSD system.

For simplicity of documentation, this design guide shows selecting the CAPSENSE™ parameters in PSoC™ Creator. You can use the same procedure to set the parameters in ModusToolbox™. However, in ModusToolbox™, you set the Sense clock and Modulator clock using divider values while in the PSoC™ Creator you specify the frequency value directly in the configurator. For more details on configuring CAPSENSE™, see the [Component datasheet/middleware](#) document.

Table 10 CAPSENSE™ component hardware parameters

Sl. No.	CAPSENSE™ parameter in PSoC™ Creator	CAPSENSE™ parameter in ModusToolbox™
1	Sense cock frequency	Sense clock divider
2	Sense clock source	Sense clock source
3	Modulator clock frequency	Modulator clock divider
4	Modulator IDAC	Modulator IDAC
5	Compensation IDAC	Compensation IDAC
6	Scan resolution	Scan resolution

5.3.2.2.1 Using SmartSense to determine hardware parameters

Parameters listed in [Table 10](#) are CAPSENSE™ hardware parameters. Tuning these parameters manually for optimal value is a time-consuming task. You can use SmartSense to determine these hardware parameters and take it as an initial value for manual tuning. You can fine-tune these values to further optimize the scan time, SNR, power consumption, or improving EMI/EMC capability of the CAPSENSE™ system.

Set the tuning mode to SmartSense and configure default values for parameters other than finger capacitance. See the [SmartSense](#) section for the tuning procedure and use the Tuner GUI to read back all the hardware parameters set by SmartSense. See the [Component datasheet/middleware document](#) for more details on how to use the Tuner GUI.

[Figure 67](#) shows the best hardware parameter values in the Tuner GUI that are tuned by SmartSense for a specific hardware to sense a minimum finger capacitance of 0.1 pF.

5 CAPSENSE™ performance tuning

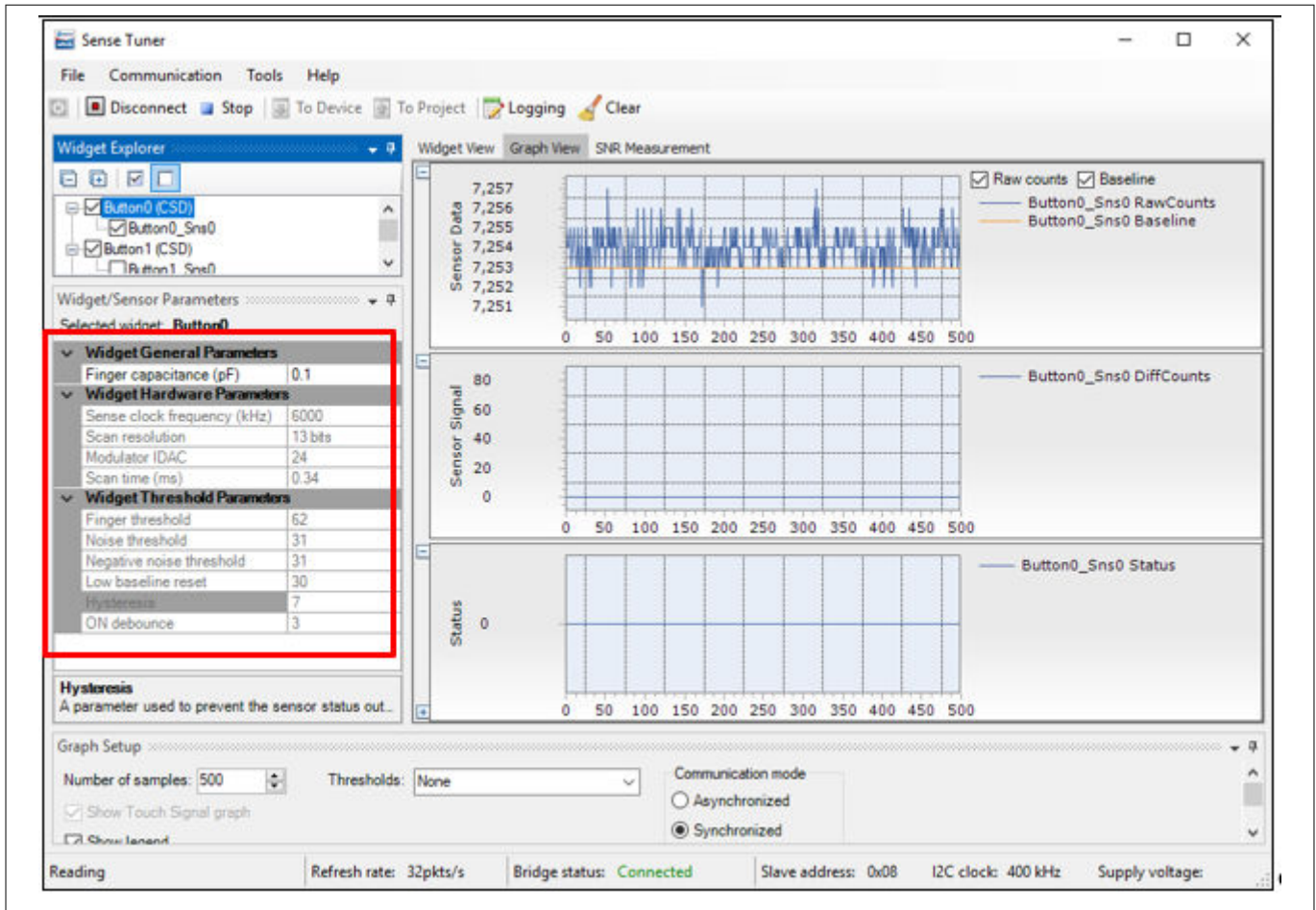

Figure 67 Read-back hardware parameter values in Tuner GUI

5.3.2.2.2 Manually tuning hardware parameters

Sense clock parameters

There are two parameters that are related to Sense clock: Sense clock source and Sense clock frequency.

Sense clock source

Select “Auto” to let the Component automatically choose the best sense clock source from Direct, PRSx, and SSCx for each widget. If not selecting Auto, then select the clock source based on the following:

- Use pseudo random sequence (PRSx) modes to remove flat-spots
- Use spread spectrum clock (SSCx) modes for reducing EMI/EMC noise at a particular frequency. This feature is available in the PSoC™ 4 S-Series, PSoC™ 4100S Plus, PSoC™ 4100PS, and PSoC™ 6 family of devices. In this case, the frequency of the sense clock is spread over a predetermined range
- Use the direct clock for absolute capacitance measurement

When selecting PRSx as the sense clock source, ensure that the sequence completes within one conversion cycle; not letting the sequence complete may cause high noise in raw count, that is, $T_{PRS} \ll T_{SCAN}$.

For PRS clock, use the following equations to calculate one PRS sequence completion cycle and scan time.

5 CAPSENSE™ performance tuning

$$T_{SCAN} = \frac{2^N - 1}{F_{MOD}}, \text{ here } N \text{ is the Scan resolution}$$

Equation 35 **Sensor scan time**

$$T_{PRS} = \frac{2^{N_PRS} - 1}{F_{SW}}, \text{ here } N_PRS \text{ is either } 8 \text{ or } 12$$

Equation 36 **PRS sequence period**

See the [Component datasheet/middleware document](#) for more details on the rules and recommendations for SSCx selection.

Sense clock frequency

The sense clock frequency should be selected so that the sensor will charge and discharge completely in each sense clock period as [Figure 39](#) shows.

This requires that the maximum sense clock frequency be chosen per [Equation 31](#).

$$F_{SW}(\text{maximum}) = \frac{1}{10R_{SeriesTotal}C_P}$$

Equation 37 **Sense clock maximum frequency**

$$R_{SeriesTotal} = R_{EXT} + R_{GPIO}$$

Equation 38 **Total series resistance**

Here, C_p is the sensor parasitic capacitance, and $R_{SeriesTotal}$ is the total series-resistance, including the 500 Ω resistance of the internal switches, the recommended external series resistance of 560 Ω (connected on PCB trace connecting sensor pad to the device pin), and trace resistance if using highly resistive materials (example ITO or conductive ink); that is, a total of 1.06 kΩ plus the trace resistance.

The value for C_P can be estimated using the CSD Built-in-Self-test API; `GetSensorCapacitance()`. See the [Component datasheet/middleware document](#) for details.

[Equation 31](#) shows that it is best to use the maximum clock frequency to have a good gain; however, you should ensure that the sensor capacitor fully charges and discharges as shown in [Figure 39](#).

Generally, the C_p of the shield electrode will be higher compared to sensor C_p . For good liquid tolerance, the shield signal should satisfy the condition mentioned in [Shield electrode tuning theory](#). If it is not satisfied, reduce the sense clock frequency further to satisfy the condition.

Modulator clock frequency

The modulator clock governs the conversion time for capacitance-to-digital conversion, also called the “sensor scan time” (see [Equation 8](#)).

A lower modulator clock frequency implies the following:

Longer conversion time (see [Equation 23](#) and [Equation 21](#))

- Lower peak-to-peak noise on raw count because of longer integration time of the sigma-delta converter
- Wider [Flat-spots](#)

5 CAPSENSE™ performance tuning

Select the highest frequency for the shortest conversion time and narrower flat spots for most cases. Use slower modulator clock to reduce peak-to-peak noise in raw counts if required.

Modulation and compensation IDACs

CSD supports two IDACs: Modulation IDAC and Compensation IDAC that charge C_{MOD} as [Figure 35](#) shows. These govern the [Conversion gain in dual IDAC mode](#) for capacitance-to-digital conversion. The CapSense Component allows the following configurations of the IDACs:

- Enabling or disabling of Compensation IDAC
- Enabling or disabling of Auto-calibration for the IDACs
- DAC code selection for Modulator and Compensation IDACs if auto-calibration is disabled

Compensation IDAC

Enabling the compensation IDAC is called “dual IDAC” mode, and results in increased signal as explained in [Conversion gain in dual IDAC mode](#). Enable the compensation IDAC for most cases. Disable the compensation IDAC only if you want to free the IDAC for other general-purpose analog functions.

Auto-calibration

This feature enables the firmware to automatically calibrate the IDAC to achieve the required calibration target of 85%. It is recommended to enable auto-calibration for most cases. Enabling this feature will result in the following:

- Fixed raw count calibration to 85% of maximum raw count even with part-to-part C_p variation
- Avoids [Flat-spots](#)
- Automatically selects the optimum gain

If your design environment includes large temperature variation, you may find that the 85% IDAC calibration level is too high, and that the raw counts saturate easily over large changes in temperature, leading to lower SNR. If this is the case, you can adjust the calibration level lower by using `CapSense_CSDCalibrateWidget()` in your firmware.

For proper functioning of CAPSENSE™ under diverse environmental conditions, it is recommended to avoid very low or high IDAC codes. For a 7-bit IDAC, it is recommended to use IDAC codes between 18-110 from the possible 0 to 127 range. You can use CAPSENSE™ tuner to confirm that the auto-calibrated IDAC values fall in this recommended range. If the IDAC values are out of the recommended range, based on [Equation 30](#), [Equation 31](#) and [Equation 33](#), you may change the V_{Ref} or F_{SW} to get the IDAC code in proper range.

Disable IDAC auto-calibration if a change in C_p needs to be detected by measuring the raw count level at reset, for example:

- Detecting large variations in sensor C_p across boards or layout problems
- Detecting finger touch at reset
- Advanced CAPSENSE™ methods like liquid-level sensing, for example, to have different raw count level for different liquid levels at reset

Selecting DAC codes

This is not the recommended approach. However, this could be used only if you want to disable auto-calibration for any reason. To get the IDAC code, you may first configure CAPSENSE™ Component with auto-calibration enabled and all other hardware parameters the same as required for final tuning and read back the calibrated IDAC values using [Tuner GUI](#). Then, re-configure the CAPSENSE™ Component to disable auto-calibration and use the obtained IDAC codes as fixed DAC codes read-back from the [Tuner GUI](#).

5 CAPSENSE™ performance tuning

Scan resolution

It governs the sensor scan time per [Equation 29](#) and the conversion gain per [Equation 30](#), [Equation 25](#), and [Equation 27](#). Scan resolution needs to be selected to maintain a balance between the signal and scan time.

Higher scan resolution implies the following:

- Longer scan time per [Equation 29](#)
- Higher SNR on raw counts (increase in resolution increases the signal at a disproportionate rate to noise)

In general, it is recommended to tune the resolution to achieve as high SNR as possible; however if the system is constrained on power consumption and/or response time, set the lowest resolution to achieve at-least 5:1 SNR in the end system.

Note: You should tune the scan resolution for less than 10:1 SNR only if you have scan time or power number constraints.

5.3.2.2.3 Tuning shield electrode

The shield related parameters need to be additionally configured or tuned differently when you enable the Shield electrode in the CSD sensing method for liquid tolerance or reducing the C_p of the sensor.

Shield electrode tuning theory

Ideally, the shield waveform should be exactly the same as that of the sensor as explained in [Driven shield signal and shield electrode](#). However, in practical applications, the shield waveform may have a higher settling time and an overshoot error. Observe the sensor and shield waveform in the oscilloscope; an example waveform is shown in [Driven shield signal and shield electrode](#). The shield waveform should settle to the sensor voltage within 90% of ON time of the sense clock waveform and the overshoot error of the shield signal with respect to V_{REF} should be less than 10%.

If these conditions are not satisfied, you will observe a change in raw count of the sensors when touching the shield hatch; in addition, if inactive sensors are connected to shield as mentioned in [Inactive sensor connection](#), touching one sensor can cause change in raw count on other sensors, which indicates that there is cross talk if the shield electrode is not tuned properly.

In SmartSense, the sense clock frequency is automatically set. Check if these conditions are satisfied. If not satisfied, switch to [Manual tuning](#) and set the Sense clock frequency manually so that these conditions are satisfied. You can also tune the [Shield SW resistance](#) parameter to reduce the overshoot error.

5 CAPSENSE™ performance tuning

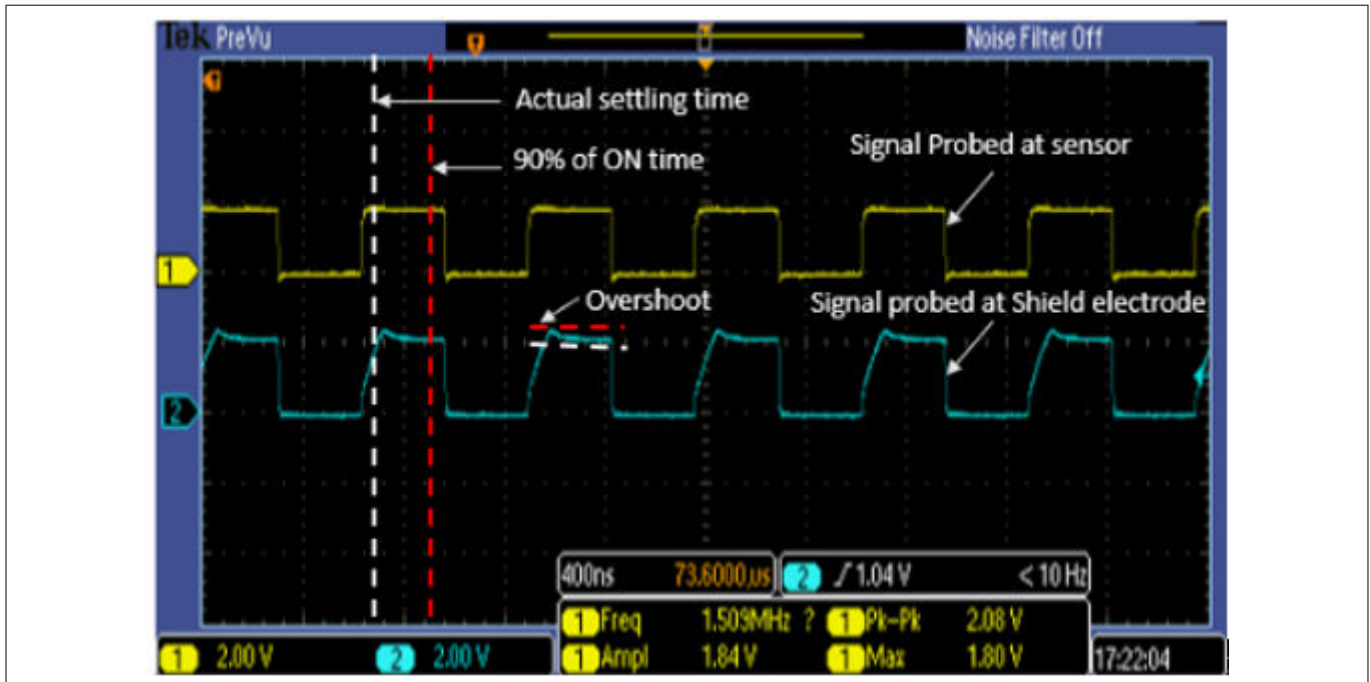

Figure 68 Properly tuned shield waveform

Tuning shield-related parameters

Enable shield tank capacitor

Enabling a shield tank capacitor increases the drive strength of the shield thus allowing the shield signal to settle to the sensor voltage faster as required. It is recommended to use the shield tank capacitor for PSoC™ 4A-S and PSoC™ 6 MCU family of devices. For PSoC™ 4A, PSoC™ 4A-L, and PSoC™ 4A-M family of devices, the shield tank capacitor does not prove very advantageous because it doubles the shield series resistance. It is recommended to keep this option disabled for these device families.

Shield electrode delay

For proper operation of the shield electrode, the shield signal should match the sensor signal in phase. Due to the difference in trace lengths of the sensor and shield electrodes, the shield waveform may arrive earlier to the sensor waveform. You can use an oscilloscope to view both sensor and shield signals to verify this condition. If they are not aligned, use this option to add delay to the shield signal to align the two signals. Available delays vary depending on the device selected.

Shield SW resistance

This parameter controls the shield signal rise and fall times to reduce EMI. This parameter is valid only for PSoC™ 4 S-Series, PSoC™ 4100S Plus, PSoC™ 4100PS, and PSoC™ 6 MCU family of devices. The default value of shield switch resistance is Medium. Table 11 shows the effect of the Shield SW resistance value. You should select this value based on the application requirement; in addition, ensure that it satisfies the conditions in Shield electrode tuning theory.

5 CAPSENSE™ performance tuning

Table 11 Shield SW resistance selection guidelines

Lower switch resistance	Higher switch resistance
Large overshoot error	Smaller overshoot error
Higher electromagnetic emission	Lower electromagnetic emission
Faster settling time that is, higher maximum sense clock frequency	Slower settling time that is, lower maximum sense clock frequency

Number of shield electrodes

This parameter specifies the number of shield electrodes required in the design. Most designs work with one dedicated shield electrode; however, some designs require multiple dedicated shield electrodes for ease of PCB layout routing or to minimize the PCB real estate used for the shield layer. See [Layout guidelines for shield electrode](#).

Inactive sensor connection

When the shield electrode is enabled for liquid-tolerant designs, or if you want to use shield to reduce the sensor parasitic capacitance, this option should be specified as “Shield”; otherwise, select “Ground”. However, there is a risk of higher radiated emission due to inactive sensors getting connected to Shield. In such situations, use the CAPSENSE™ API to manually control inactive sensor connections. Instead of connecting all unused sensors to the shield, connect only the opposing inactive sensors or inactive sensors closer to the sensor being scanned to shield for reducing the radiated emission.

5.3.2.3 Selecting CAPSENSE™ software parameters

CAPSENSE™ software parameters govern the sensor status based on the raw count of a sensor. [Table 12](#) provides a list of CAPSENSE™ software parameters. These parameters apply to both CSD and CSX sensing methods. This section defines these parameters with the help of [Baseline](#), and provides guidance on how to adjust these parameters for optimal performance of your design. [Table 13](#) shows the recommended values for the software threshold parameter and they are applicable for most of the designs. However, if there are any external noise present in the end system, you must modify these thresholds accordingly to avoid any sensor false trigger.

Table 12 CAPSENSE™ component widget threshold parameters

Sl. No.	CAPSENSE™ component parameter name in PSoC™ Creator/ModusToolbox™
1.	Finger threshold
2.	Noise threshold
3.	Hysteresis
4.	ON debounce
5.	Sensor auto-reset
6.	Low baseline reset
7.	Negative noise threshold

5 CAPSENSE™ performance tuning

Table 13 Recommended values for the threshold parameters

Sl. No.	CAPSENSE™ threshold parameter	Recommended value
1.	Finger threshold	80 percent of signal
2.	Noise threshold	40 percent of signal
3.	Hysteresis	10 percent of signal
4.	ON debounce	3
5.	Low baseline reset	30
6.	Negative noise threshold	40 percent of signal

5.3.2.3.1 Baseline

After tuning the CAPSENSE™ Component for a given C_p , the raw count value of a sensor may vary gradually due to changes in the environment such as temperature and humidity. Therefore, the CAPSENSE™ Component creates a new count value known as baseline by low-pass filtering the raw counts. **Baseline** keeps track of, and compensates for, the gradual changes in raw count. The baseline is less sensitive to sudden changes in the raw count caused by a touch. Therefore, the baseline value provides a reference level for computing signal.

Figure 69 shows the concept of raw count, baseline, and signal.

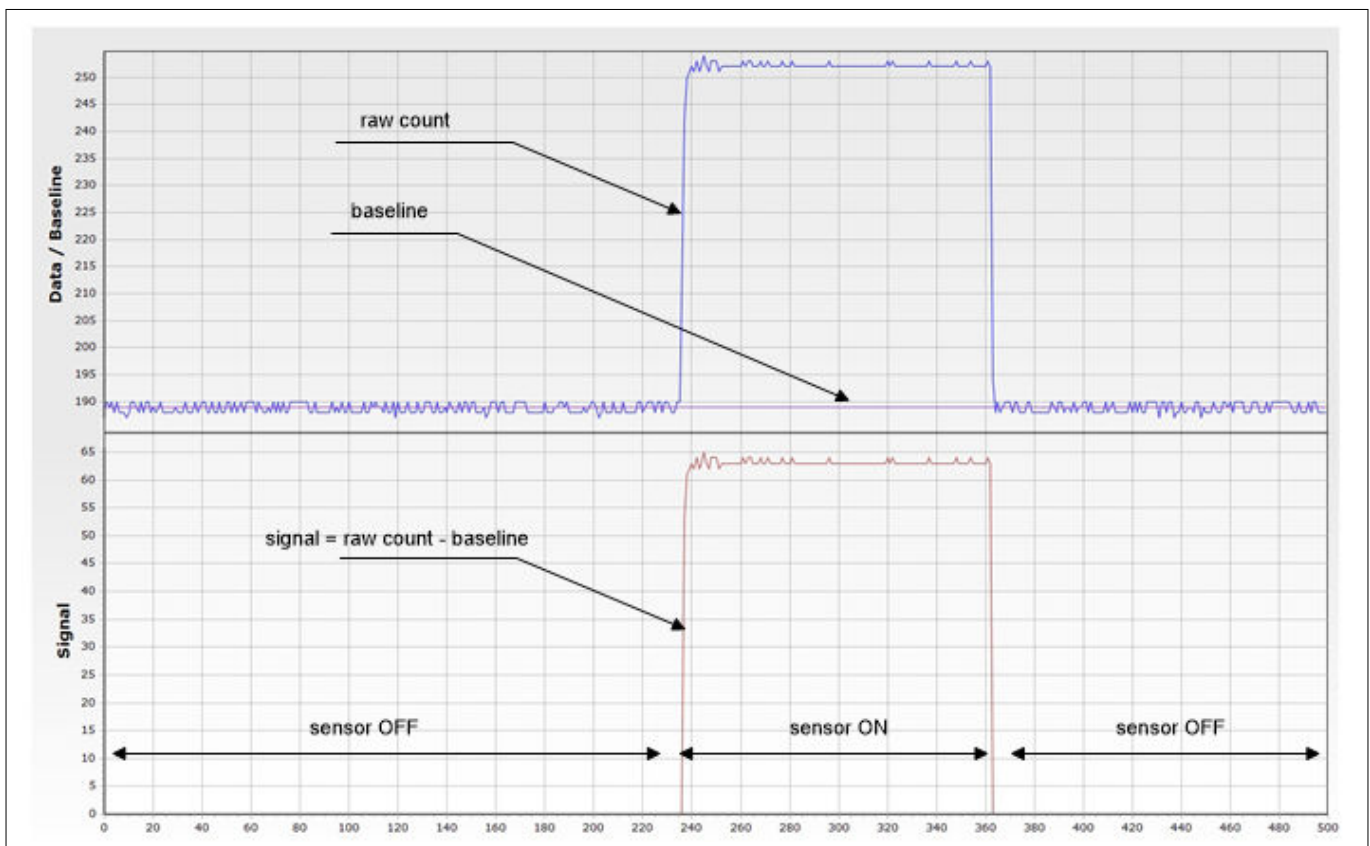

Figure 69 Raw count, baseline, and signal

5.3.2.3.2 Baseline update algorithm

To properly tune the CAPSENSE™ software, that is, the threshold parameters, it is important to understand how baseline is calculated and how the threshold parameters affect the baseline update.

5 CAPSENSE™ performance tuning

Baseline is a low-pass-filtered version of raw counts. As Figure 70 shows, baseline is updated by low-pass-filtering raw counts if the current raw count is within a range of $(Baseline - \text{Negative noise threshold})$ to $(Baseline + \text{Noise threshold})$. If the current raw count is higher than baseline by a value greater than noise threshold, baseline remains at a constant value equal to prior baseline value.

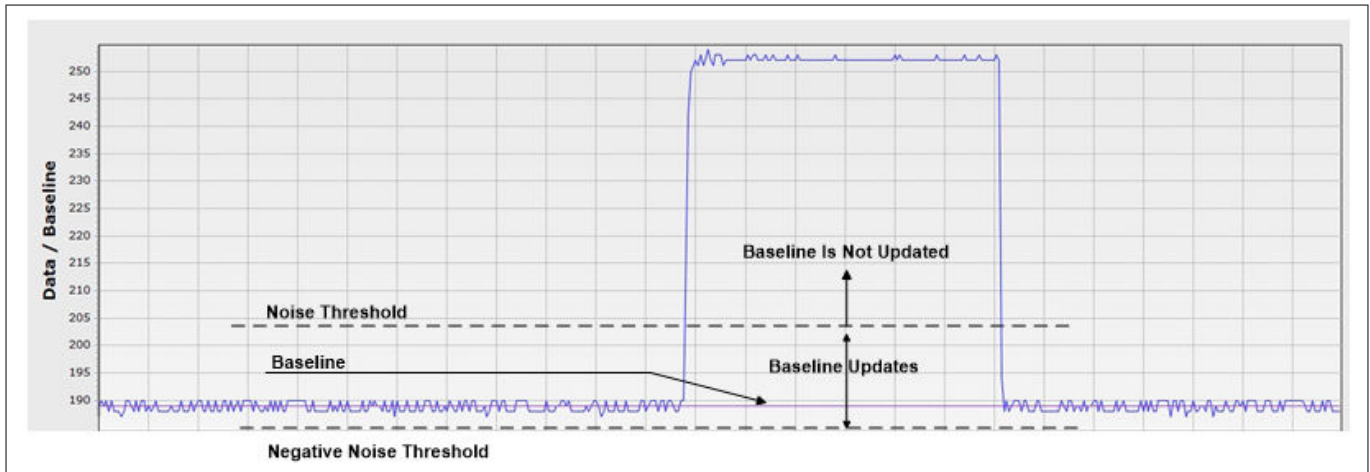

Figure 70 Baseline update algorithm

If the current raw count is below baseline minus negative noise threshold, baseline again remains constant at a value equal to prior baseline value for Low baseline reset number of sensor scans. If the raw count continuously remains lower than baseline minus noise threshold for low baseline reset number of scans, the baseline is reset to the current raw count value and starts getting updated again, as Figure 71 shows.

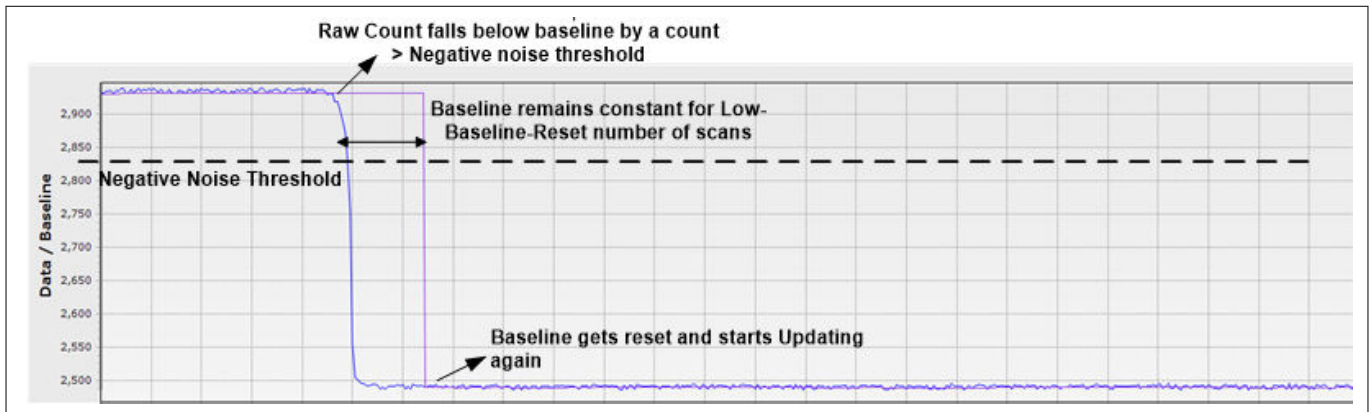

Figure 71 Low baseline reset

5.3.2.3.3 Finger threshold

The finger threshold parameter is used along with the hysteresis parameter to determine the sensor state, as Equation 39 shows.

$$\text{Sensor state} = \{ \text{ON if } (Signal \geq \text{Finger Threshold} + \text{Hysteresis}) \\ \text{OFF if } (Signal \leq \text{Finger Threshold} - \text{Hysteresis}) \}$$

Equation 39 Sensor state

Note: Signal in the above equation refers to the difference: raw count - baseline, when the sensor is touched, as Figure 69 shows.

5 CAPSENSE™ performance tuning

It is recommended to set finger threshold to 80 percent of the signal. This setting allows enough margin to reliably detect sensor ON/OFF status over signal variations across multiple PCBs.

5.3.2.3.4 Hysteresis

The hysteresis parameter is used along with the finger threshold parameter to determine the sensor state, as Equation 39 and Figure 72 show. Hysteresis provides immunity against noisy transitions of sensor state. The hysteresis parameter setting must be lower than the finger threshold parameter setting. It is recommended to set hysteresis to 10 percent of the signal.

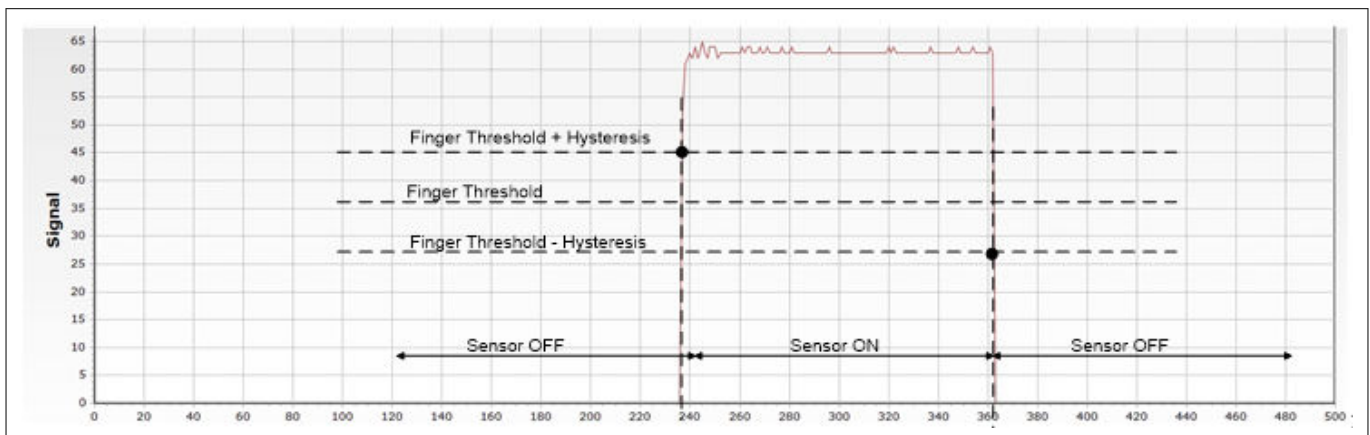

Figure 72 Hysteresis

5.3.2.3.5 Noise threshold

For single-sensor widgets, such as buttons and proximity sensors, the noise threshold parameter sets the raw count limit above which the baseline is not updated, as Figure 70 shows. In other words, the baseline remains constant as long as the raw count is above *baseline + noise threshold*. This prevents the baseline from following raw counts during a finger touch.

The noise threshold value should always be lower than the *finger threshold - hysteresis*. It is recommended to set noise threshold to 40 percent of the signal.

If the noise threshold is set to a low value, the baseline will remain constant if raw counts suddenly increase by a small amount, say because of small shifts in power supply or shifts in ground voltage because of high GPIO sink current and so on.

On the other hand, if the noise threshold is set to a value close to *finger threshold - hysteresis*, the baseline may keep updating even when the sensor is touched. This will lead to reduced signal

Note: $(signal = raw\ count - baseline)$ and the sensor state may not be reported as ON.

5.3.2.3.6 Negative noise threshold

The negative noise threshold parameter sets the raw count limit below which the baseline is not updated for the number of samples specified by the low baseline reset parameter as Figure 71 shows.

Negative noise threshold ensures that the baseline does not fall low because of any high amplitude repeated negative noise spikes on raw count caused by different noise sources such as electrostatic discharge (ESD) events.

It is recommended to set the negative noise threshold parameter value to be equal to the noise threshold parameter value.

5 CAPSENSE™ performance tuning

5.3.2.3.7 Low baseline reset

This parameter is used along with the negative noise threshold parameter. It counts the number of abnormally low raw counts required to reset the baseline as Figure 71 shows.

If a finger is placed on the sensor during device startup, the baseline is initialized to the high raw count value at startup. When the finger is removed, raw counts fall to a lower value. In this case, the baseline should track the low raw counts. The Low Baseline Reset parameter helps to handle this event. It resets the baseline to the low raw count value when the number of low samples reaches the low baseline reset number.

Note: In this case, when the finger is removed from the sensor, the sensor will not respond to finger touches for a low baseline reset time given by Equation 40.

$$\text{Low Baseline Reset Time} = \frac{\text{Low Baseline Re set parameter value}}{\text{Scan rate}}$$

Equation 40 Low baseline reset time

The low baseline reset parameter should be set to meet following conditions:

- Low baseline reset time is greater than the time for which negative noise (due to noise sources such as ESD events) is expected to last
- Low baseline reset time is lower than the time in which a sensor is expected to start responding again after the finger kept on sensor during device startup is removed from the sensor

The low baseline reset parameter is generally set to a value of 30.

5.3.2.3.8 Debounce

This parameter selects the number of consecutive CAPSENSE™ scans during which a sensor must be active to generate an ON state from the component. Debounce ensures that high-frequency, high-amplitude noise does not cause false detection.

$$\begin{aligned} \text{Sensor state} = \{ & \text{ON if } (\text{Signal} \geq \text{Finger Threshold} + \text{Hysteresis}) \text{ for scans} \geq \text{debounce} \\ & \text{OFF if } (\text{Signal} \leq \text{Finger Threshold} - \text{Hysteresis}) \\ & \text{OFF if } (\text{Signal} \geq \text{Finger Threshold} + \text{Hysteresis}) \text{ for scans} < \text{debounce} \} \end{aligned}$$

Equation 41 Sensor state with debounce

The Debounce parameter impacts the response time of a CAPSENSE™ system. The time it takes for a sensor to report ON after the raw counts value have increased above finger threshold + hysteresis because of finger presence, is given by Equation 42.

$$\text{Sensor response time} = \frac{\text{Debounce}}{\text{Scan Rate}}$$

Equation 42 Relationship between debounce and sensor response time

The Debounce parameter is generally set to a value of ‘3’ for reliable sensor status detection. It can be raised or lowered based on the noise aspects of the end user system.

5.3.2.3.9 Sensor auto reset

Enabling the Sensor Auto Reset parameter causes the baseline to always update regardless of whether the signal is above or below the noise threshold.

5 CAPSENSE™ performance tuning

When auto reset is disabled, the baseline only updates if the current raw count is within a range of $(Baseline - Negative\ Noise\ Threshold)$ to $(Baseline + Noise\ Threshold)$ as Figure 70 shows and the [Baseline update algorithm](#) describes. However, when Auto Reset is enabled, baseline is always updated if the current raw count is higher than $(Baseline - Negative\ Noise\ Threshold)$ as Figure 73 shows.

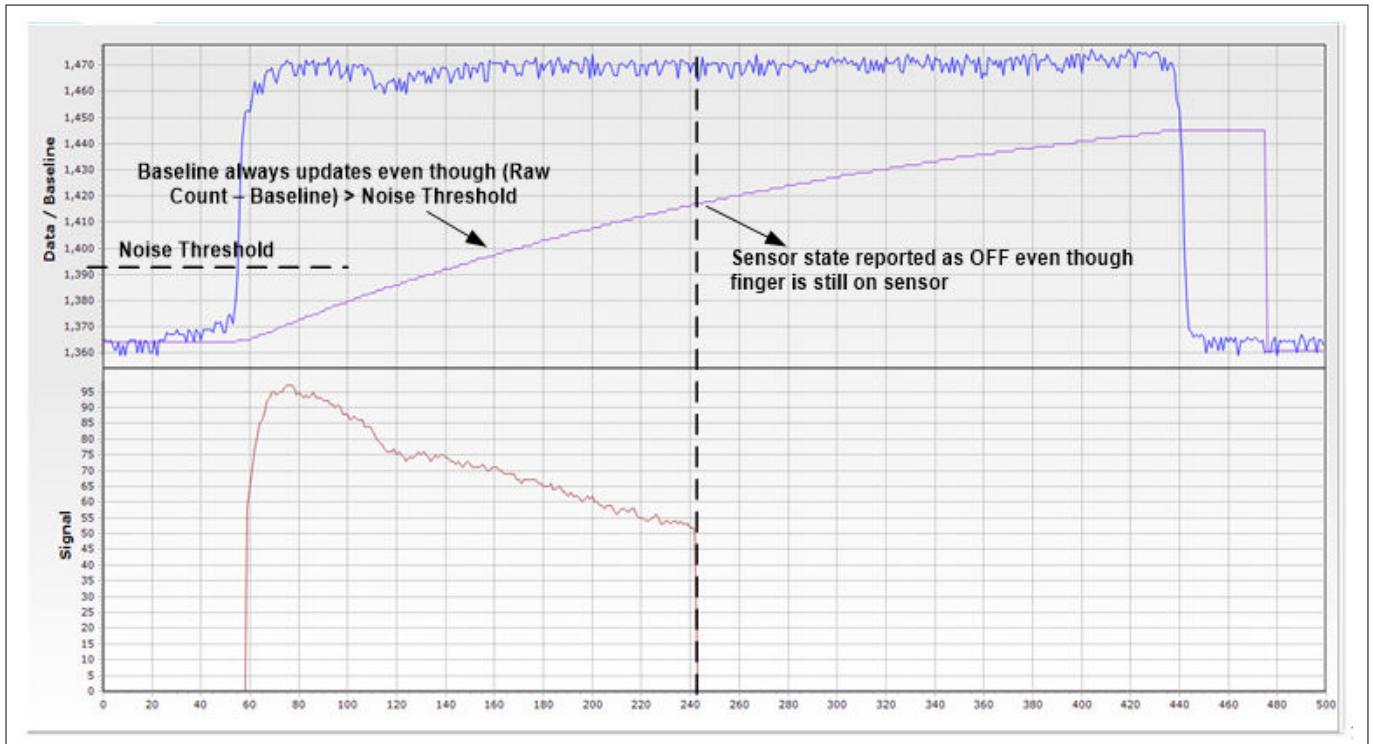

Figure 73 Baseline update with sensor auto reset enabled

Because the baseline is always updated when sensor auto reset is enabled, this setting limits the maximum time duration for which the sensor will be reported as pressed. However, enabling this parameter prevents the sensors from permanently turning on if the raw count suddenly rises without anything touching the sensor. This sudden rise can be caused by a large power supply voltage fluctuation, a high-energy RF noise source, or a very quick temperature change.

Enable this option if you have a problem with sensors permanently turning on when the raw count suddenly rises without anything touching the sensor.

5.3.2.3.10 Multi-frequency scan

Enabling multi-frequency scan, the CAPSENSE™ component performs a sensor scan with three different sense clock frequencies and obtains corresponding difference count. The median of the sensor difference-count is selected for further processing. Use this feature for robust operation in the presence of external noise at a certain sensor scan frequency. This option is not available in SmartSense Full Autotune mode. See the code example [CE227719 CAPSENSE™ with multi-frequency scan](#).

5.3.2.4 Button widget tuning

Figure 74 illustrates an overview of the CSD button tuning procedure.

5 CAPSENSE™ performance tuning

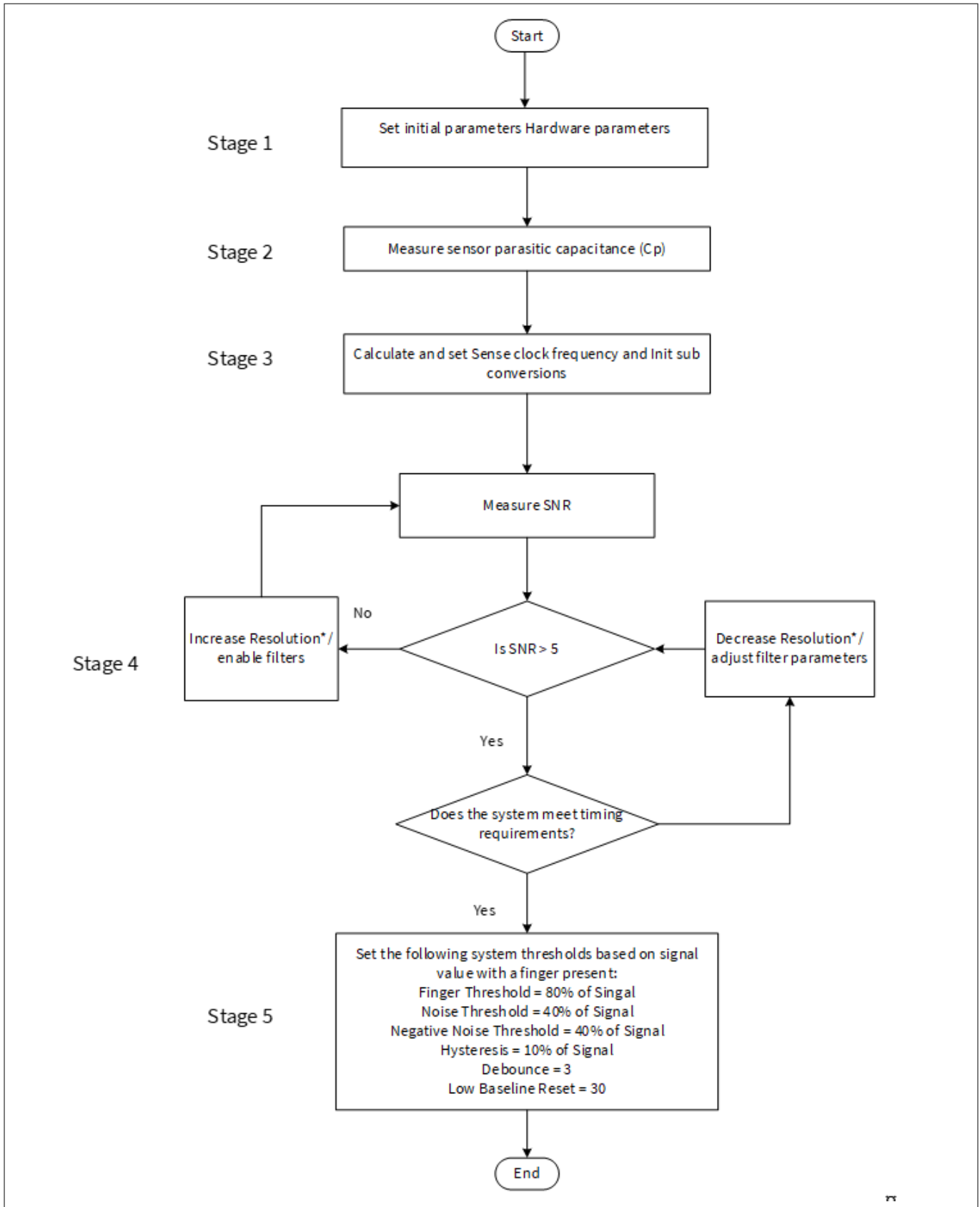

Figure 74 CSD button widget tuning flowchart

Attention: For fifth-generation CAPSENSE™, change number of sub-conversions (N_{Sub}) instead of resolution.

5 CAPSENSE™ performance tuning

To review the hardware design, see the [Sensor construction](#) and [PCB layout guidelines](#) sections in the [Design considerations](#) chapter. Also, see the [Tuning debug FAQs](#) section for guidelines on advanced debug.

As explained in [Chapter 5.1](#), Manual tuning requires effort to tune optimum CAPSENSE™ parameters, but allows strict control over characteristics of capacitive sensing system, such as response time and power consumption. The button is tuned for reliable touch detection to avoid false triggers in noisy environment.

The [CE230926 PSoC™ 4: CAPSENSE™ CSD button tuning](#) explains tuning of self-capacitance based button widgets in the Eclipse IDE for ModusToolbox™ using the CAPSENSE™ [Tuner GUI](#). For details on the Component and all related parameters, see the [Component datasheet](#).

5.3.2.5 Slider widget tuning

A slider has many segments, each of which is connected to the CAPSENSE™ input pins of the PSoC™ device. Unlike the simple on/off operation of a button widget sensor, slider widget sensors work together to track the location of a finger or other conductive object. Because of this, the slider layout design should ensure that the C_p of all the segments in a slider remain as close as possible. Keeping similar C_p values between sensors will help minimize the tuning effort and ensure an even response across the entire slider. See [Slider design](#) for details on slider layout design guidelines to avoid nonlinearity in the centroid, ensure that the signal from all the slider segments is equal, as [Figure 75](#) shows, when a finger is placed at the center of the slider segment. If the signal of the slider segments is different, then the centroid will be nonlinear, as [Figure 76](#) shows.

Note: In PSoC™ Creator and in ModusToolbox™, a centroid of 0xFFFF and 0x0000 is reported respectively when a finger is not detected on the slider, or when none of the slider segments report a difference count value greater than the Finger Threshold parameter.

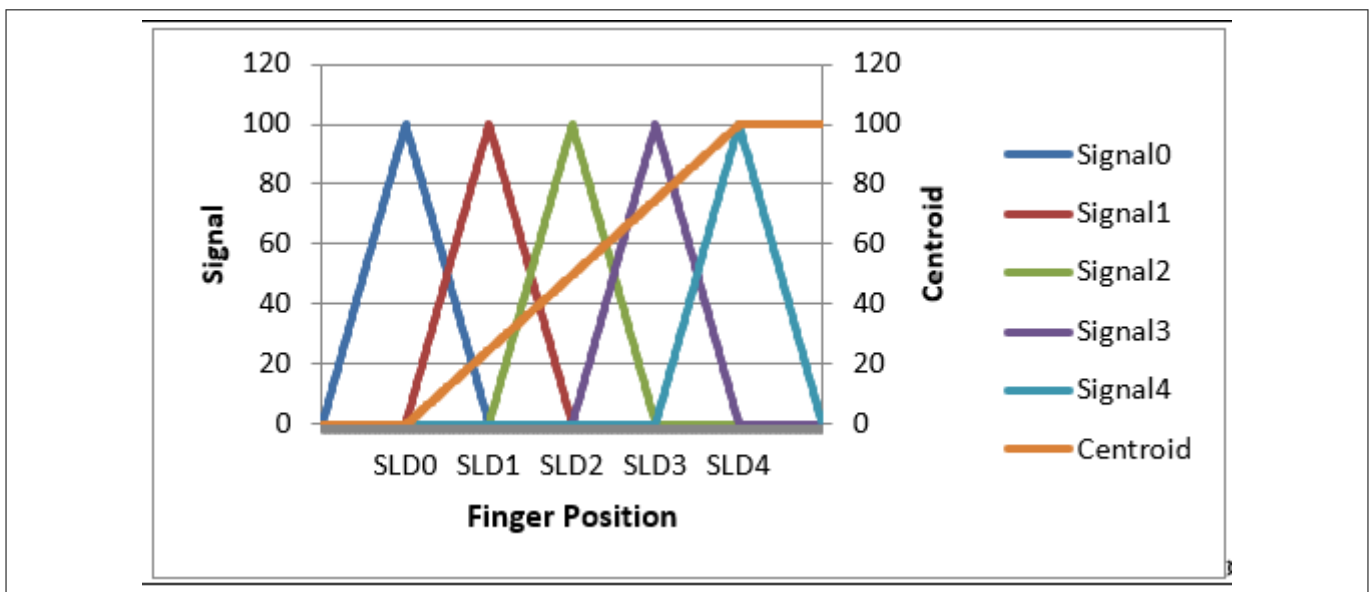

Figure 75 Response of centroid versus finger location when signals of all slider elements are equal

Note: $Signal = Raw\ Count - Baseline$

5 CAPSENSE™ performance tuning

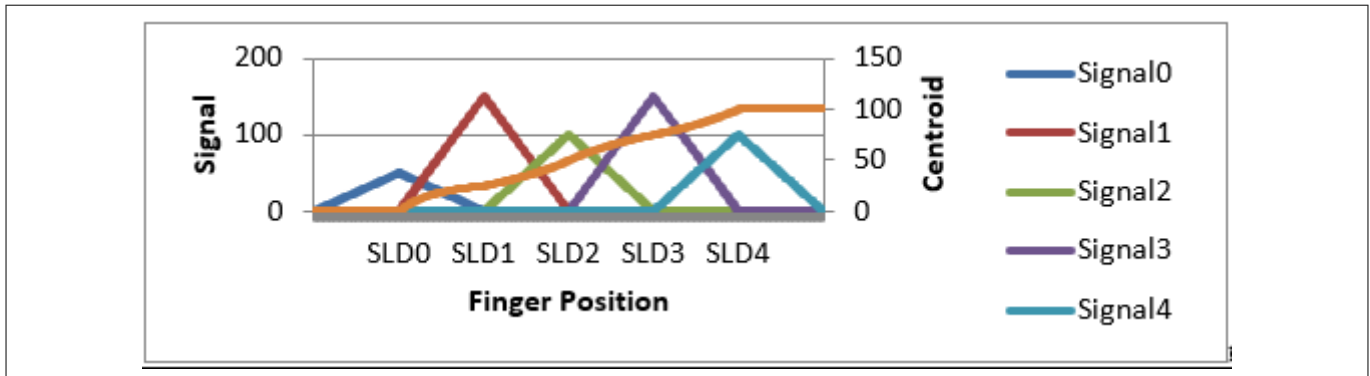

Figure 76 Response of centroid versus finger location when the signal of all slider elements are different

A linear response for the reported finger position (that is, the Centroid position) versus the actual finger position on a slider requires that the slider design is such that whenever a finger is placed anywhere between the middle of the segment SLD_n and middle of segment SLD_{n-1}, other than the exact middle of slider segments, exactly two sensors report a valid signal ⁸⁾. If a finger is placed at the exact middle of any slider segment, the adjacent sensors should report a difference count = noise threshold. These conditions are required since the centroid position calculation is based on the closest segment to the finger and two neighboring segments as shown in Equation 43.

$$\text{centroid position} = \left(\frac{S_{x+1} - S_{x-1}}{S_{x+1} + S_{x-1}} + x \right) \times \frac{\text{Resolution}}{(n - 1)}$$

Equation 43 Centroid algorithm used by CAPSENSE™ component in PSoC™

Where,

Resolution = API resolution set in the CAPSENSE™ Component Customizer

n = Number of sensor elements in the CAPSENSE™ Component Customizer

x = Index of element which gives maximum signal

s_i = Different counts (with subtracted noise threshold value) of the slider segment

Figure 77 shows an overview of the CSD slider tuning procedure.

⁸⁾ Here, a valid signal means that the difference count of the given slider segment is greater than or equal to the noise threshold value.

5 CAPSENSE™ performance tuning

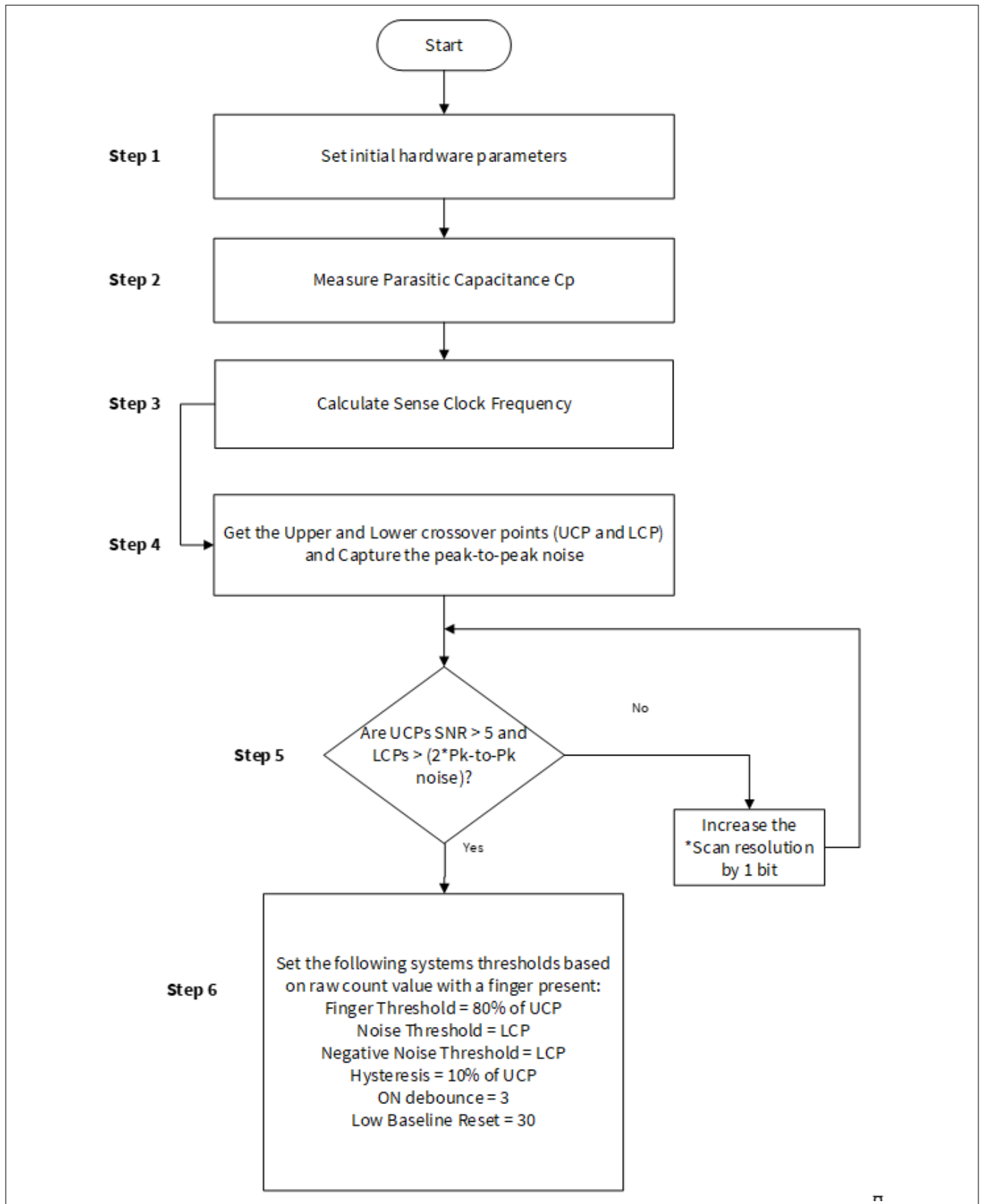

Figure 77 CSD slider widget tuning flowchart

Attention: For fifth-generation CAPSENSE™, change number of sub-conversions (N_{Sub}) instead of resolution.

5 CAPSENSE™ performance tuning

The upper crossover point (UCP) and lower crossover point (LCP) are obtained as shown in Figure 78. Refer to [CE229521 – PSoC™ 4 CAPSENSE™ CSD Slider tuning](#) which demonstrates how to manually tune a self-capacitance based Slider widget on PSoC™ Creator and [CE230493 – PSoC™ 4: CAPSENSE™ CSD Slider tuning on Eclipse IDE for ModusToolbox™](#).

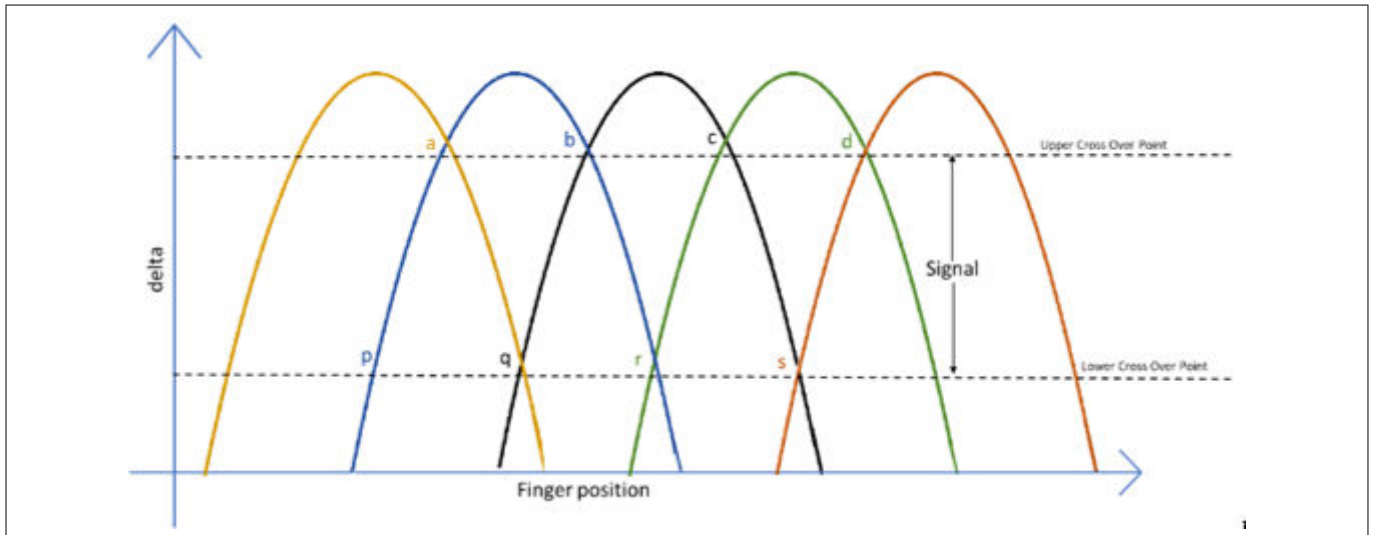

Figure 78 Difference count (delta) vs finger position

5.3.2.6 Touchpad widget tuning

Please refer to [AN234185 PSoC™ 4 CAPSENSE™ Touchpad design guide](#) for touchpad tuning guidelines.

5.3.2.7 Proximity widget tuning

For tuning a proximity sensor, see [AN92239 - Proximity sensing with CAPSENSE™](#).

5.3.3 CSX sensing method (third- and fourth-generation)

This chapter explains the basics of manual tuning using the CSX sensing method. It also explains the hardware parameters that influence a manual tuning procedure.

5.3.3.1 Basics

5.3.3.1.1 Conversion gain and CAPSENSE signal

In a mutual-capacitance sensing system, the $Rawcount_{counter}$ is directly proportional to the mutual-capacitance between the Tx and Rx electrodes, as Equation 44 shows.

$$Rawcount_{counter} = G_{CSX}C_M$$

Equation 44 Raw count relationship to sensor capacitance

Where,

G_{CSX} = Capacitance to digital conversion gain of CAPSENSE™ CSX

C_M = Mutual-capacitance between the Tx and Rx electrodes.

5 CAPSENSE™ performance tuning

Figure 80 shows the relationship between raw count and mutual capacitance of the CSX sensor. The tunable parameters of the conversion gain in Equation 45 are F_{TX} , N_{MOD} , F_{MOD} and IDAC.

The approximate value of this conversion gain is:

$$G_{CSX} = \frac{2 V_{TX} F_{TX} MaxCount}{IDAC}$$

Equation 45 **Capacitance to digital converter gain**

$$MaxCount = \frac{F_{Mod} N_{Sub}}{F_{TX}}$$

Equation 46 **MaxCount equation**

Where,

V_{TX} = Voltage at the Tx node of the sensor as shown in Figure 79

$$V_{TX} = V_{ON} - V_{OFF}$$

The value of V_{TX} is always V_{DDIO} or V_{DDD} (if V_{DDIO} is not available) if the Tx clock frequency can completely charge and discharge the Tx electrode. F_{TX} is the Tx clock frequency, I_{DAC} is the current drawn for charging and discharging the C_{INT} capacitors, and N_{sub} is the number of sub-conversions.

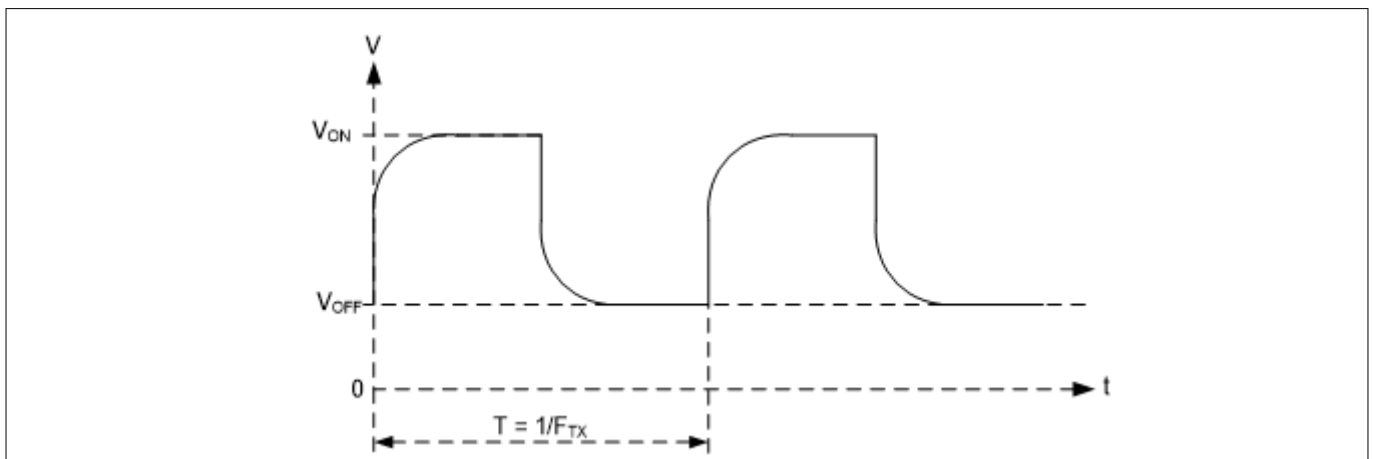

Figure 79 **Voltage at Tx node of the CSX sensor**

Note: The raw count observed from the Component is given by Equation 47. See CAPSENSE™ CSX sensing method (third- and fourth-generation) for more details on $Rawcount_{component}$.

$$Rawcount_{Component} = MaxCount - Rawcount_{counter}$$

Equation 47 **Rawcount_{Component}**

5 CAPSENSE™ performance tuning

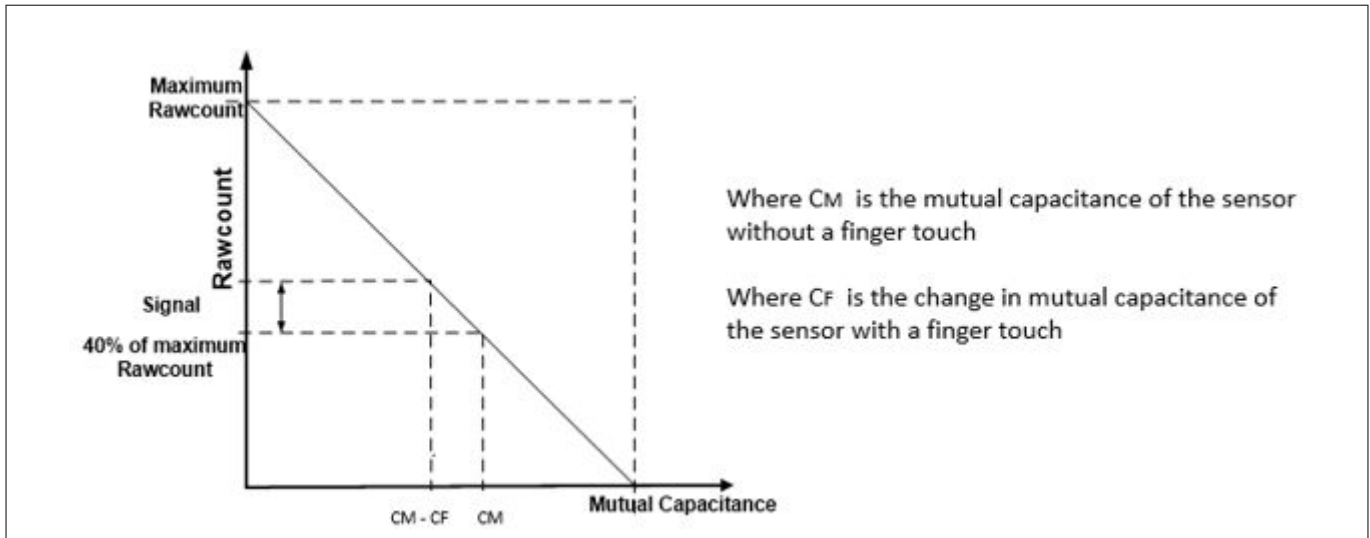

Figure 80 Raw count vs Sensor mutual-capacitance

5.3.3.2 Selecting CAPSENSE™ hardware parameters

CAPSENSE™ hardware parameters govern the conversion gain and. Table 14 lists the CAPSENSE™ hardware parameters that apply to the CSX sensing method. Table 14 also shows the mapping of each parameter in the PSoC™ Creator CAPSENSE™ component to the one in the ModusToolbox™ middleware. For simplicity of documentation, this design guide shows selecting the CAPSENSE™ parameter using the CAPSENSE™ configurator in PSoC™ Creator. The same procedure could be followed in configuring CAPSENSE™ in ModusToolbox™. However, in ModusToolbox™, you set the Tx clock and Modulator clock using divider values. On the other hand, in PSoC™ Creator, you specify the frequency value directly in the configurator. See Component datasheet/middleware document.

Table 14 CAPSENSE™ signal component hardware parameters

Sl #	CAPSENSE™ parameter in PSoC™ Creator	CAPSENSE™ parameter in ModusToolbox™
1	Modulator clock frequency	Modulator clock divider
2	Tx clock source	Tx clock source
3	Tx clock frequency	Tx clock divider
4	IDAC	IDAC
5	Number of sub-conversions	Number of sub-conversions

5.3.3.2.1 Tx clock parameters

There are two parameters that are related to the Tx clock: Sense clock source and Sense clock frequency.

Tx clock source

Select “Auto” to let the Component automatically choose the best Tx clock source between Direct and Spread spectrum clock (SSCx) for each widget. If not selecting Auto, select the clock source based on the following:

- Direct – Clock signal with a fixed clock frequency. Use this option for most cases
- Spread spectrum clock (SSCx) – If you chose this option, the Tx clock signal frequency is dynamically spread over a predetermined range. Use this option for reduced EMI interference and avoiding Flat-spots

5 CAPSENSE™ performance tuning

However, when selecting SSCx clock, you need to select the Tx clock frequency, Modulator clock frequency, and number of sub conversion such that the conditions mentioned in [Component datasheet/ModusToolbox™ CAPSENSE™ configurator guide](#) for SSCx clock source selection are satisfied.

Tx clock frequency

The Tx clock frequency determines the duration of each sub-conversion as explained in the [CAPSENSE™ CSX sensing method \(third- and fourth- generation\)](#) Chapter. The Tx clock signal must completely charge and discharge the sensor parasitic capacitance; it can be verified by checking the signal in an oscilloscope, or it can be set using the [Equation 48](#). In addition, you should ensure that the auto-calibrated IDAC code lies in the mid-range (for example, 30-90) for the selected . If the auto-calibrated IDAC code lies out of the recommended range, tune such that it IDAC falls in the recommended range and satisfies [Equation 48](#).

$$F_{TX} < \frac{1}{10 R_{SeriesTx} C_{PTx}}$$

Equation 48 Condition for selecting Tx clock frequency

To minimize the scan time, as [Equation 49](#) shows, it is recommended to use the maximum Tx clock frequency available in the component drop-down list that satisfies the criteria.

$$T_{CSX} = \frac{N_{Sub}}{F_{Tx}}$$

Equation 49 Scan time of CSX sensor

Where, N_{Sub} = [Number of sub-conversions](#).

Additionally, if you are using the SSCx clock source, ensure that you select the Tx clock frequency that meets the conditions mentioned in [Component datasheet/middleware document/ModusToolbox™ CAPSENSE™ configurator guide](#) in addition to these conditions.

The maximum value of FTX depends on the selected device. For the PSoC™ 4 S-Series, PSoC™ 4100S Plus, PSoC™ 4100PS, and PSoC™ 6 MCU family of devices, the maximum FTX is 3000 kHz and for other devices it is 300 kHz.

5.3.3.2.2 Modulator clock frequency

It is best to choose the highest allowed clock frequency for the given device because a higher modulator clock frequency leads to a higher sensitivity/signal, increased accuracy, and lower noise for a given C_M to digital count conversion as [Equation 36](#) and [Equation 37](#) indicate. Also, a higher value of F_{mod}/F_{tx} ensures lower width of [Flat-spots](#) in C_M to raw count conversion.

5.3.3.2.3 IDAC

It is recommended to enable IDAC auto-calibration. It is best to avoid very high and very low IDAC codes. The recommended IDAC code range is between 30-90. If the IDAC values are away from the recommended range, tune the Tx clock frequency to adjust the IDAC level. If the IDAC is failing to calibrate properly, it may be due to low C_M in the design. Refer to the section [I am observing a low CM for my CSX button](#) for mitigating impact of low C_M in the design.

5 CAPSENSE™ performance tuning

5.3.3.2.4 Number of sub-conversions

The number of sub-conversions decides the sensitivity of the sensor and sensor scan time. From [Equation 14](#) for a fixed modulator clock and Tx clock, increasing the number of sub-conversions (N_{Sub}) increases the signal and SNR. However, increasing the number of sub-conversions also increases the scan time of the sensor per [Equation 50](#).

$$\text{Scan time} = \frac{N_{Sub}}{F_{Tx}}$$

Equation 50 CSX scan time

Initially, set the value to a low number (for example, 20), and use the Tuner GUI to find the SNR of the sensor. If the SNR is not > 5:1 with the selected N_{Sub} , try to increase the N_{Sub} in steps such that the SNR requirement is met.

5.3.3.3 Selecting CAPSENSE™ software parameters

CAPSENSE™ software parameters for mutual-capacitance are the same as that for self-capacitance; therefore, these parameters could be selected as mentioned in the section [Selecting CAPSENSE™ software parameters](#) Selecting CAPSENSE™ software parameters.

5.3.3.4 Button widget tuning

[Figure 81](#) illustrates an overview of the CSX button tuning procedure.

5 CAPSENSE™ performance tuning

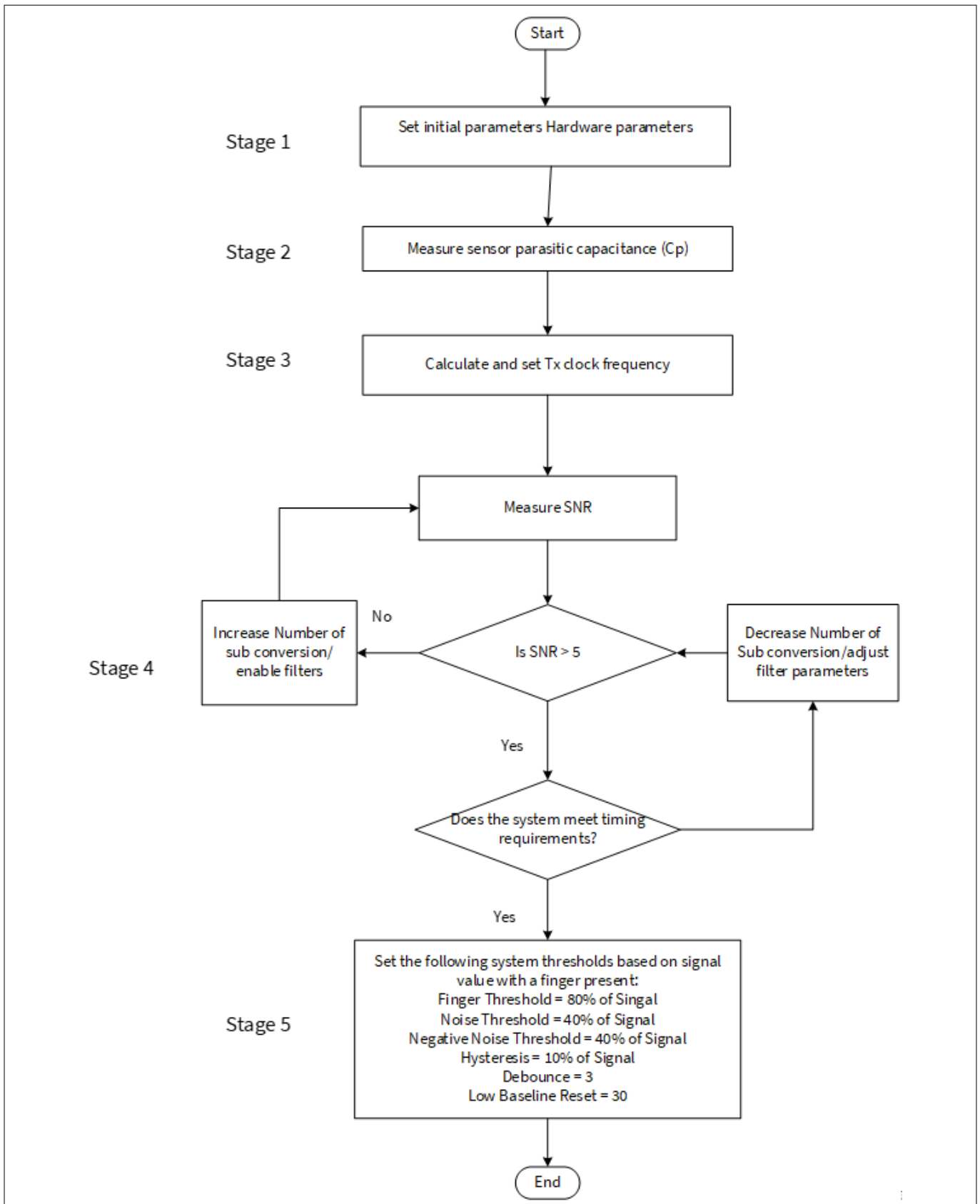

Figure 81 CSX button widget tuning example

* To review the hardware design, see the [Sensor construction](#) and [PCB layout guidelines](#) sections in the [Design considerations](#) chapter. Also, see the [Tuning debug FAQs](#) section for guidelines on advanced debug

5 CAPSENSE™ performance tuning

The [CE230660 PSoC™ 4: CAPSENSE™ CSX button tuning](#) explains tuning of mutual-capacitance based button widgets in the Eclipse IDE for ModusToolbox™ and [CE228931 – PSoC™ 4 CAPSENSE™ CSX button tuning](#) in PSoC™ Creator using the CAPSENSE™ tuner. For details on the Component and all related parameters, see the [Component datasheet](#).

5.3.3.5 Touchpad widget tuning

Please refer to [AN234185 PSoC™ 4 CAPSENSE™ Touchpad design guide](#) for touchpad tuning guidelines.

5.3.4 CSD-RM sensing method (fifth-generation and fifth-generation low-power)

This chapter explains the basics of manual tuning using CSD-RM sensing method (Fifth-Generation and Fifth-Generation Low-Power). It also explains the hardware and software parameters that influence the CSD-RM sensing method and the procedure of manual tuning for button, slider, touchpad and proximity widgets.

5.3.4.1 Basics

5.3.4.1.1 Conversion gain and CAPSENSE™ signal

Conversion gain will influence how much signal the system sees for a finger touch on the sensor. If there is more gain, the signal is higher, and a higher signal means a higher achievable [Signal-to-noise ratio \(SNR\)](#).

Note: An increased gain may result in an increase in both signal and noise. However, if required, you can use firmware filters to decrease noise. For details on available firmware filters, see [Table 9](#).

Conversion gain in single CDAC

In the single CDAC mode, the raw count is directly proportional to the sensor capacitance.

$$\text{raw count} = G_{CSD} C_S$$

Equation 51 Raw count relationship to sensor capacitance

Where,

C_S = Sensor capacitance

$C_S = C_P$ if there is no finger present on sensor

$C_S = (C_P + C_F)$ when there is a finger present on the sensor

G_{CSD} = Capacitance to digital conversion gain of CAPSENSE™ CSD. The approximate value of this conversion gain according to [Equation 18](#) and [Equation 51](#) is shown using [Equation 52](#).

$$G_{CSD} = \text{MaxCount} \frac{1}{\text{SnsClk}_{Div} \cdot C_{ref}}$$

Equation 52 Capacitance to digital converter gain

Where,

The equation for raw count in the single CDAC mode, according to [Equation 52](#) and [Equation 51](#) is shown in [Equation 53](#).

5 CAPSENSE™ performance tuning

$$\text{raw count} = N_{\text{Sub}} \frac{C_S}{C_{\text{ref}}}$$

Equation 53 **Single CDAC mode raw counts**

Where,

N_{Sub} = Number of sub-conversions

$SnsClk_{\text{Div}}$ = sense clock divider

C_S = Sensor capacitance

C_{ref} = Reference capacitance

$C_{\text{ref}} = \text{RefCDACCode} \times C_{\text{lsb}}$

RefCDACCode = Reference CDAC value

$C_{\text{lsb}} = 8.86 \text{ fF}$

The tunable parameters of the conversion gain are C_{ref} , $SnsClk_{\text{Div}}$, and N_{Sub} . Figure 82 shows a plot of raw count versus sensor capacitance.

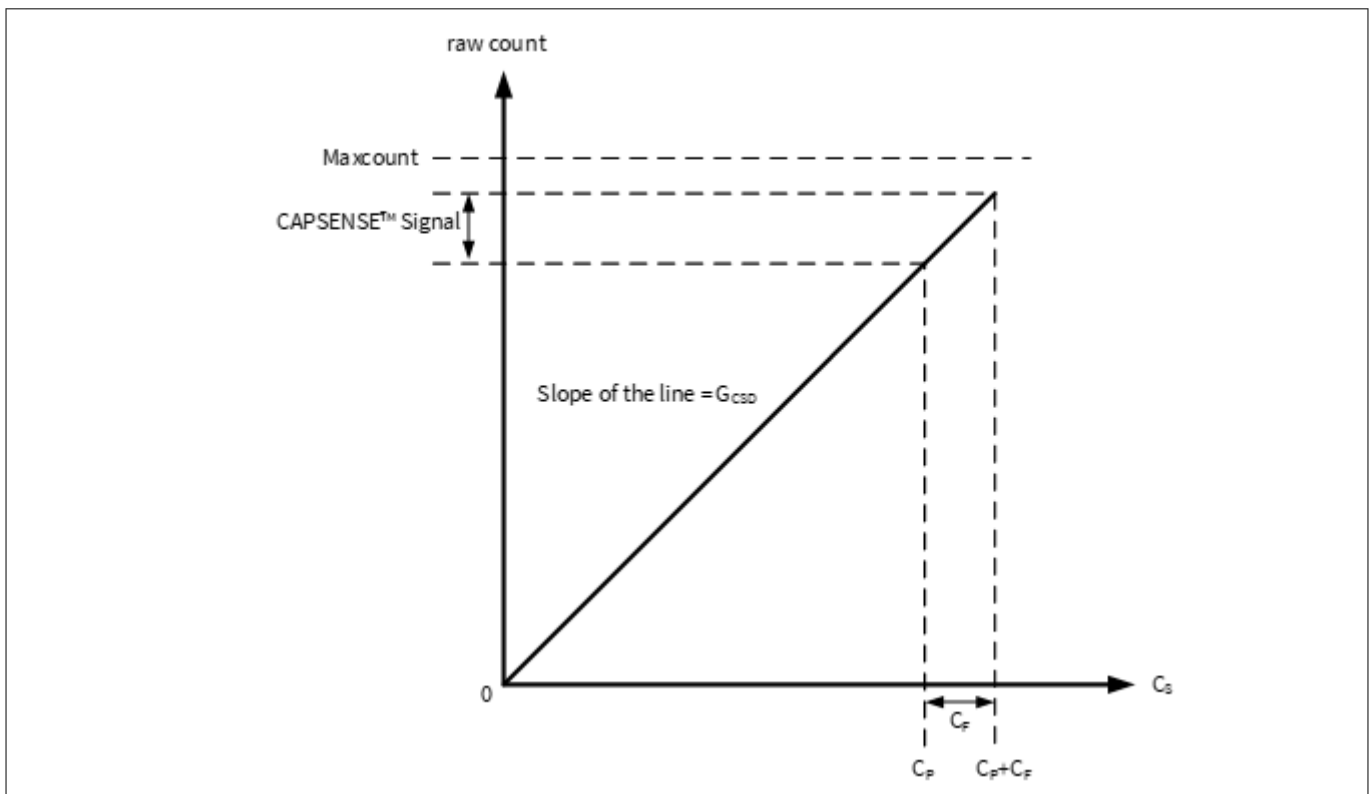

Figure 82 **Raw count versus sensor capacitance**

The change in raw counts when a finger is placed on the sensor is called CAPSENSE™ signal. Figure 83 shows how the value of the signal changes with respect to the conversion gain.

5 CAPSENSE™ performance tuning

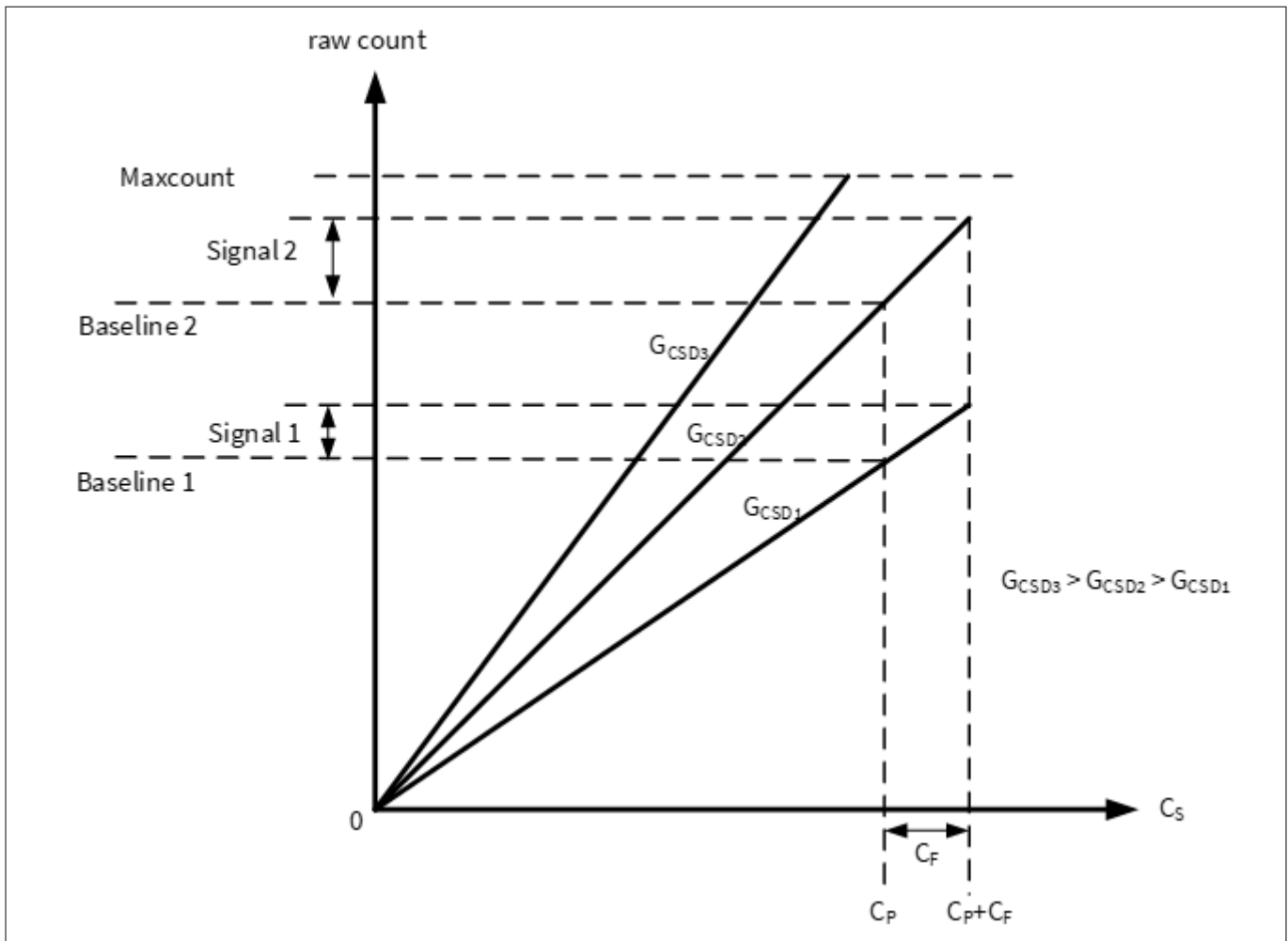

Figure 83 Signal values for different conversion gains

Figure 83 shows three plots corresponding to three conversion gain values G_{CSD3} , G_{CSD2} , and G_{CSD1} . An increase in the conversion gain results in higher signal value. However, this increase in the conversion gain also moves the raw count corresponding to C_P (that is, Baseline) towards the maximum value of raw count (Maxcount). For very high gain values, the raw count saturates as the plot of G_{CSD3} shows. Therefore, tune the conversion gain to get a good signal value while avoiding saturation of raw count. Tune the CSD-RM parameters such that when there is no finger on the sensor, that is when $C_S = C_P$, the raw count = 85% of Maxcount as Figure 84 shows. This ensures maximum gain, with enough margin for the raw count to grow because of environmental changes, and not saturate on finger touches.

5 CAPSENSE™ performance tuning

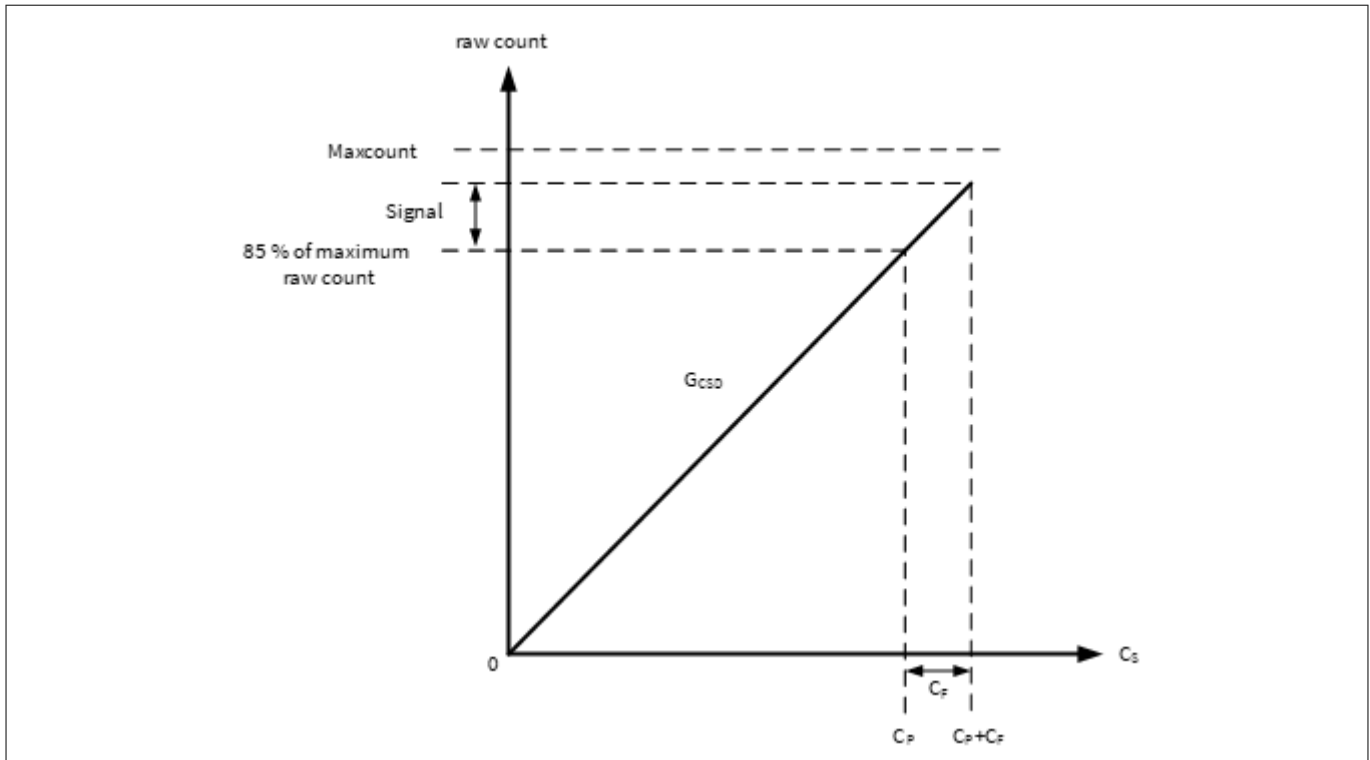

Figure 84 Recommended tuning

Conversion gain in dual CDAC mode

The equation for raw count in the dual CDAC mode, according to Equation 19 and Equation 51 is shown in Equation 54.

$$\text{rawcount} = G_{CSD} C_S - \text{Maxcount} \times \frac{2 \times C_{comp}}{C_{ref} \text{CompCLK}_{div}}$$

Equation 54 Dual CDAC mode raw counts

Where,

$$\text{Maxcount} = N_{Sub} * \text{SnsClk}_{Div}$$

SnsClk_{Div} = Sense clock divider

N_{Sub} = Number of sub-conversions

C_{ref} = Reference capacitance

C_{comp} = Compensation capacitance

CompCLK_{Div} = CDAC compensation divider

C_S = Sensor capacitance

$$C_{ref} = \text{RefCDACCode} * C_{lsb}$$

$$C_{comp} = \text{CompCDACCode} * C_{lsb}$$

RefCDACCode = Reference CDAC value

CompCDACCode = Compensation CDAC value

$C_{lsb} = 8.86\text{fF}$

G_{CSD} is given by Equation 52.

5 CAPSENSE™ performance tuning

In both single CDAC and dual CDAC mode, tune the CSD-RM parameters, so that when there is no finger on the sensor, that is when $C_S = C_P$, the raw count = 85% of Maxcount, as Figure 85 shows, to ensure high conversion gain, to avoid Flat-spots, and to avoid raw count saturation due to environmental changes.

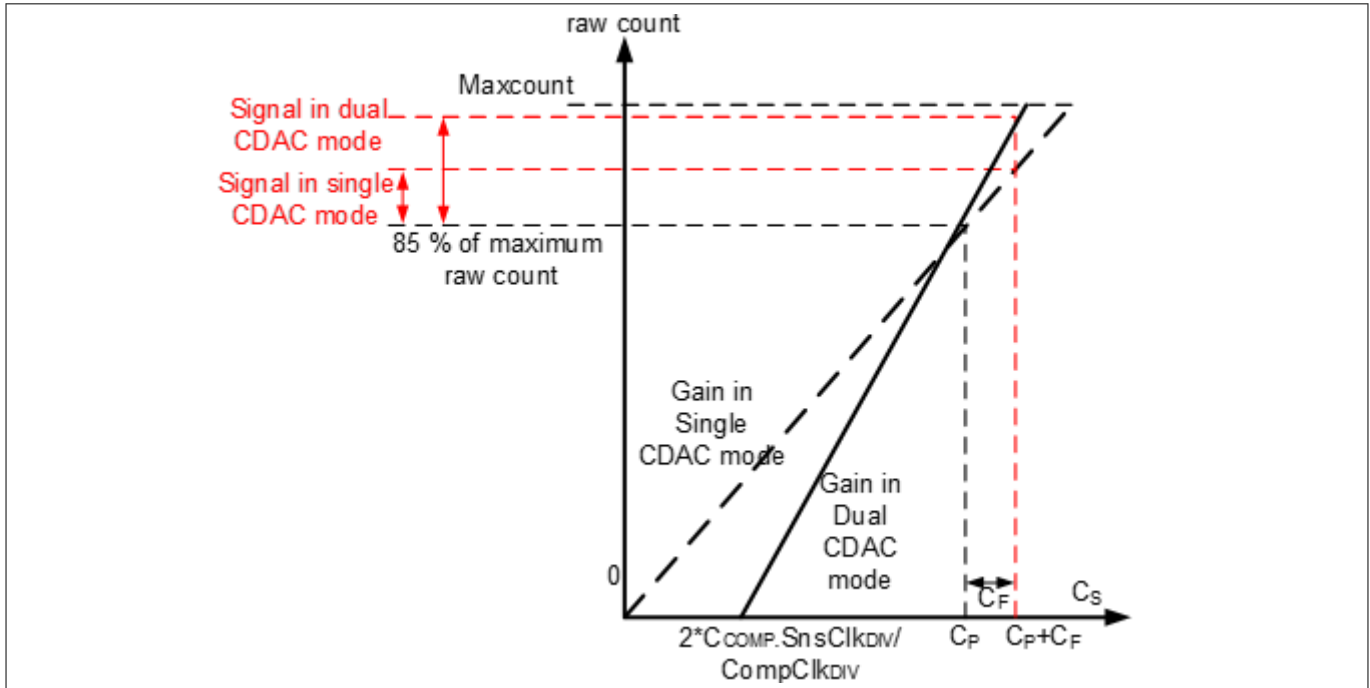

Figure 85 Recommended tuning in dual CDAC mode

As Figure 85 shows, the 85% requirement restricts to a fixed gain in single-CDAC mode, while in dual-CDAC mode, gain can be increased by moving the C_S axis intercept to the right (by increasing $CompClk_{Div}$) and correspondingly decreasing the modulator CDAC switching ($SnsClk_{Div}$) to still achieve raw count = 85% of Maxcount for $C_S = C_P$. Using dual CDAC mode this way brings the following changes to the Raw Count versus C_P graph:

- Use of compensation CDAC introduces a non-zero intercept on the C_S axis as shown in Equation 55

$$C_S \text{ axis intercept} = \left(\frac{2 \times C_{comp} SnsClk_{Div}}{CompClk_{Div}} \right)$$

Equation 55 C_S axis intercept with regards to C_{comp}

- The value of C_{ref} in the dual CDAC mode is half compared to the value of C_{ref} in the single CDAC mode (all other parameters remaining the same), so the gain G_{CSD} in the dual CDAC mode is double the gain in the single CDAC mode according to Equation 31. Thus, the signal in the dual CDAC mode is double the signal in the single CDAC mode for a given number of sub-conversions (N_{sub}).

While manually tuning a sensor, refer Equation 31, Equation 33 and the following points:

1. Higher gain leads to increased sensitivity and better overall system performance. However, do not set the gain such that raw counts saturate, as the plot of gain G_{CSD3} shows in Figure 63. It is recommended to set the gain in such a way that the raw count corresponding to C_P is 85 percent of the maximum raw count for both the single CDAC and dual CDAC mode
2. The sense clock frequency (F_{SW}) should be set carefully; higher the frequency, higher the C_S sampling rate which allows for more F_{SW} periods and better noise averaging, but the frequency needs to be low enough to fully charge and discharge the sensor as Equation 37 indicates
3. Enabling the compensation CDAC (baseline compensation) plays a huge role in increasing the gain; it will double the gain if set as recommended in Conversion gain in dual CDAC mode. Always enable Compensation CDAC, make sure the calibrated C_{ref} is in valid range when enabling Compensation CDAC

5 CAPSENSE™ performance tuning

4. Lower the reference CDAC, higher the gain. Adjust your CDAC to achieve the highest gain, but make sure that the raw counts corresponding to C_P have enough margin for environmental changes such as temperature shifts, as indicated in [Figure 64](#) and [Figure 65](#)
5. Increasing the number of sub-conversions used for scanning increases gain. An increase in number of sub-conversions also increases the scan time according to [Equation 8](#). A balance of scan time and gain need to be achieved using number of sub-conversions (N_{sub})

5.3.4.1.2 Flat-spots

Ideally, raw counts should have a linear relationship with sensor capacitance as [Figure 62](#) and [Figure 65](#) show. However, in practice, RM converter has non-sensitivity zones, also called flat-spots or dead-zones – for a range of sensor capacitance values, the RM converter may produce the same raw count value as [Figure 86](#) shows. This range is known as a dead-zone or a flat-spot.

[Equation 56](#) shows the flat-spots relation to different CAPSENSE™ hardware parameters.

$$\text{Flatspots Width} \propto \frac{C_s^2}{C_{MOD}} \cdot \frac{F_{SW}}{F_{MOD} \cdot \text{Bal}\%}$$

Equation 56 Flat-spots width

Where,

C_s = Sensor capacitance

C_{MOD} = Modulator capacitor

F_{SW} = Frequency of the sense clock

F_{MOD} = Modulator clock frequency

Bal% = Rawcount calibration percentage

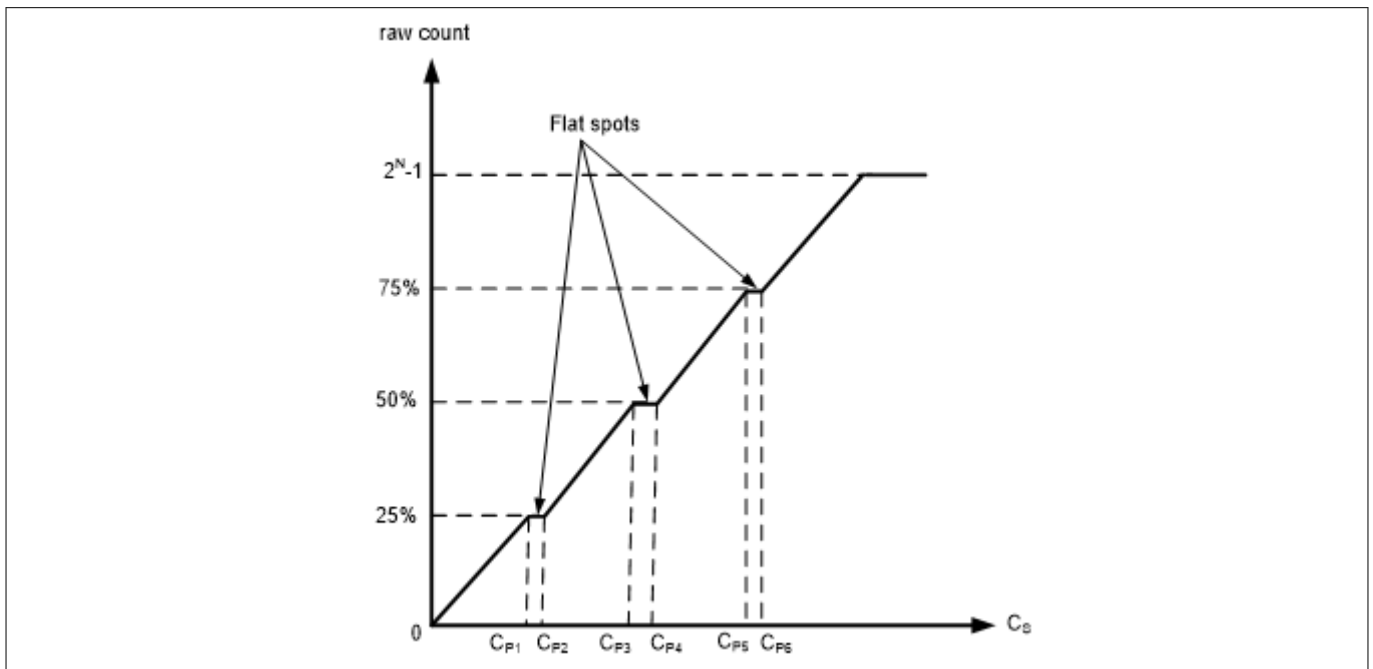

Figure 86 Flat-spots in raw counts versus sensor capacitance when direct clock is used

Flat-spots reduction techniques

1. Set rawcount calibration to 85%

5 CAPSENSE™ performance tuning

As per Equation 56, flat-spots width is inversely proportional to calibration level. Setting calibration to 85% decrease the width of flat-spots significantly.

2. Enable dithering

An additional Dither CDAC is available in Fifth-Generation CAPSENSE™ architecture, which adds white noise that moves the conversion point around the flat-spots region.

3. Enable PRS clock

These flat-spots are prominent when direct clock is used as Sense Clock source. Flat-spots are reduced if PRS is used as the sense clock source (see also section Using SmartSense to determine hardware parameters). PRS clock can results in a slight reduction of signal or sensitivity at higher rawcount calibration. Recommended to set the rawcount calibration to 65% when PRS is used as clock source.

4. Use larger C_{MOD}

The flat-spots width is inversely proportional to the C_{MOD} used. Fifth-Generation architecture supports C_{MOD} upto 10 nF and typical value is 2.2 nF. And increasing C_{MOD} have the adverse effect of increasing the noise, initialization time and minimum signal required to detect.

5. Increase sense clock divider

Increasing sense clock divider decreases flat-spots width but increases the scan time. If the flat-spot is detected, increase the Sense clock divider such that the scan time requirement is met.

Table 15 lists different the flat-spots reduction techniques in recommended priority and other considerations.

Table 15 Flat-spots reduction techniques

S. No	Flat-spots reduction techniques	Recommendation	Additional benefits	Disadvantage
1	Set rawcount calibration to 85%.	High	Improves sensitivity	-
2	Enable dithering	High	-	-
3	Enable PRS clock	Low	Improves EMI/EMC radiation and susceptibility	Needs to set rawcount calibration to 65%. Decreases sensitivity.
4	Increase C _{MOD}	Low	-	Increases noise
5	Increase sense clock divider	Low	-	Increases scan time

5.3.4.2 Selecting CAPSENSE™ hardware parameters

CAPSENSE™ hardware parameters govern the conversion gain and CAPSENSE™ signal. Table 16 lists the CAPSENSE™ hardware parameters that apply to CSD-RM sensing method. The following subsections provide guidance on how to adjust these parameters to achieve optimal performance for CAPSENSE™ CSD-RM system.

Table 16 CAPSENSE™ component hardware parameters

S. No	CAPSENSE™ parameter in ModusToolBox™
1	Scan mode
2	Scan connection method
3	Number of Init sub-conversions

(table continues...)

5 CAPSENSE™ performance tuning

Table 16 (continued) CAPSENSE™ component hardware parameters

S. No	CAPSENSE™ parameter in ModusToolBox™
4	Sense clock divider
5	Sense clock source
6	Modulator clock divider
7	Reference CDAC value
8	CDAC compensation divider
9	Compensation CDAC value
10	Number of sub-conversions
11	Enable CDAC dither

5.3.4.2.1 and 5.3.4.2.2 show selecting the CAPSENSE™ parameters in Eclipse IDE for ModusToolbox™. For more details on configuring CAPSENSE™, see the [Component datasheet/middleware document](#).

5.3.4.2.1 Using SmartSense to determine hardware parameters

Table 16 lists the CAPSENSE™ hardware parameters. Tuning these parameters manually for optimal value is a time-consuming task. You can use SmartSense to determine these hardware parameters and take it as an initial value for manual tuning. You can fine-tune these values to further optimize the scan time, SNR, power consumption, or improving EMI/EMC capability of the CAPSENSE™ system. Set the tuning mode to SmartSense and configure default values for parameters other than finger capacitance, [Sense clock source](#) and [CDAC dither](#). Set these as per the application requirement.

See the [SmartSense](#) section for the tuning procedure and use the Tuner GUI to read back all the hardware parameters set by SmartSense. See the [CAPSENSE™ tuner guide](#) for more details on how to use the Tuner GUI.

Figure 87 shows the best hardware parameter values in the Tuner GUI that are tuned by SmartSense for a specific hardware to sense a minimum finger capacitance of 0.1 pF.

5 CAPSENSE™ performance tuning

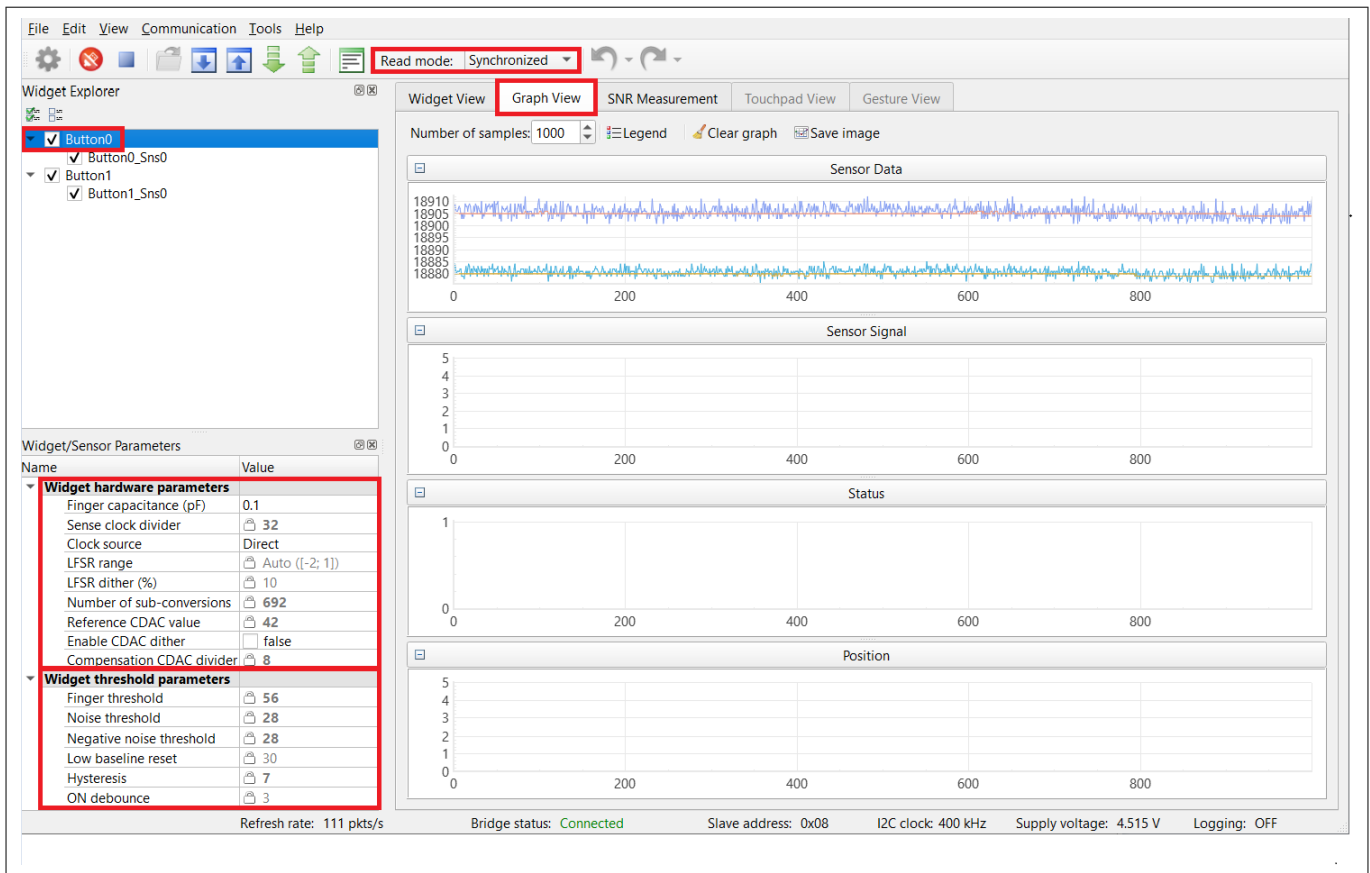

Figure 87 Read-back hardware parameter values in tuner GUI

5.3.4.2.2 Manually tuning hardware parameters

Scan mode

Scan mode can be set as CS-DMA or Interrupt Driven mode. For autonomous scanning select DMA mode and for legacy interrupt based scanning select Interrupt Driven mode.

In Fifth-Generation Low-Power CAPSENSE™, autonomous scanning is supported inherently and does not need CPU intervention, and does not require CTRLMUX and DMA.

Sensor connection method

Autonomous scanning is only available in CTRLMUX method, but the numbers of supported pins are limited in this method (see the [Device datasheet](#) for supported pins). Additionally provides better immunity to on-chip IO noise. Choose AMUXBUS method to support more number of pins in Interrupt Driven mode.

In Fifth-Generation Low-Power CAPSENSE™, all CAPSENSE™ pins support autonomous scanning mode, via the AMUXBUS, compared to the limited number of pins which were supported by the CTRLMUX in the Fifth-Generation CAPSENSE™ technology

Modulator clock frequency

The modulator clock governs the conversion time for capacitance-to-digital conversion, also called the “sensor scan time” (see [Equation 8](#)).

A lower modulator clock frequency implies the following:

5 CAPSENSE™ performance tuning

- Longer conversion time (see [Equation 55](#) and [Equation 61](#)).
- Lower peak-to-peak noise on raw count because of longer integration time of the ratiometric converter
- Wider [Flat-spots](#)

Select the highest frequency for the shortest conversion time and narrower flat-spots for most cases. Use slower modulator clock to reduce peak-to-peak noise in raw counts if required.

Based on the required Modulator clock frequency (F_{MOD}), calculate the modulator clock divider using [Equation 57](#).

$$\text{Modulator clock divider} = \frac{F_{Clock}}{F_{MOD}}$$

Equation 57 Modulator clock divider

Where,

F_{Clock} = Clock frequency connected to CAPSENSE™ block

Initialization sub-conversions

As part of initialization, C_{MOD1} and C_{MOD2} need to be charged to the required voltage ($V_{DDA}/2$). There are three phases in initialization – C_{MOD} initialization, C_{MOD} short and initialization sub-conversions. During C_{MOD} initialization phase, C_{MOD1} is pulled to GND and C_{MOD2} is pulled to V_{DDA} . During C_{MOD} short phase both capacitors are tied together so the charge is shared to produce a voltage close to $V_{DDA}/2$ on both. After these two phases the scanning is started, but rawcount is discarded for the configured number of init sub-conversions.

The number of init sub-conversions should be selected based on [Equation 58](#).

$$\text{Number of init subconversions} = \text{ceiling} \left(\frac{C_{MOD} \times V_{OS}}{V_{DDA} \times C_S \times (1 - \text{Base \%}) \times \left(\frac{1}{\text{Bal \%}} - 1\right)} \right) + 1$$

or

$$\text{Number of init subconversions} = \text{ceiling} \left(\frac{C_{MOD} \times V_{OS}}{V_{DDA} \times \text{SnClkDiv} \times C_{ref} \times (1 - \text{Bal \%})} \right) + 1$$

Equation 58 Number of init sub-conversions

Where,

C_{MOD} = Modulator capacitor

V_{OS} = Comparator offset voltage (3 mV)

Note: Use $V_{OS}=4mV$ for Automotive grade (E-grade) devices

C_S = Sensor capacitance

Base% = Baseline compensation percentage

Bal% = Rawcount calibration percentage

SnClk_{Div} = sense clock divider

C_{ref} = Reference capacitance

$C_{ref} = \text{RefCDACCode} * C_{lsb}$

RefCDACCode = Reference CDAC value

$C_{lsb} = 8.86 \text{ fF}$

5 CAPSENSE™ performance tuning

Sense clock parameters

There are two parameters that are related to Sense clock: Sense clock source and Sense clock divider.

Sense clock source

Select “Auto” to let the Component automatically choose the best Sense clock source from Direct, PRSx, and SSCx for each widget. If not selecting Auto, select the clock source based on the following:

- Use SSCx (spread spectrum clock) modes for reducing EMI/EMC noise at a particular frequency. This feature is available in PSoC™ 4S-Series, PSoC™ 4100S Plus, PSoC™ 4100PS, PSoC™ 4100S Max, PSoC™ 4000T and PSoC™ 6 family of devices. In this case, the frequency of the sense clock is spread over a predetermined range
- Use Direct clock for absolute capacitance measurement
- Use PRSx (pseudo random sequence) modes to remove flat-spots and improve EMI/EMC radiation and susceptibility. In 5th Generation CAPSENSE™, PRS clock results in a slight reduction in signal/sensitivity at higher rawcount calibration percent, hence 65% rawcount calibration is recommended when PRS clock is used

When selecting SSCx, you need to select the Sense clock frequency, Modulator clock frequency, and number of sub-conversion such that the conditions mentioned in [ModusToolbox™ CAPSENSE™ configurator guide](#) for SSCx clock source selection are satisfied.

PRS/SSC can be used to reduce the emissions, but it will increase power consumption as it needs high Nsubs. It is recommended to set Nsubs as 1024(or multiples of 1024) to obtain the maximum spread. If Nsubs are lesser than 1024 or non-multiples of 1024, the performance will be non-optimal.

Sense clock divider

The sense clock divider should be selected so that the sensor will charge and discharge completely in each sense clock period as [Figure 48](#) shows.

Note: For Fifth-Generation CSD-RM charging and discharging happens twice in a single clock period.

This requires that the maximum sense clock frequency be chosen per [Equation 59](#).

$$F_S \left(\text{maximum} \right) = \frac{1}{4 \times 5 \times R_{SeriesTotal} C_P}$$

Equation 59 **Sense clock maximum frequency**

$$R_{SeriesTotal} = R_{EXT} + R_{internal}$$

Equation 60 **Total series resistance**

Where,

C_p = Sensor parasitic capacitance

$R_{SeriesTotal}$ = Total series-resistance, including the $R_{internal}$ resistance of the internal switches, the recommended external series resistance of 560 Ω (connected on PCB trace connecting sensor pad to the device pin), and trace resistance if using highly resistive materials (example ITO or conductive ink).

$R_{internal}$ = Internal resistance, this varies based on scan and shield modes, see table [Table 17](#).

5 CAPSENSE™ performance tuning

Table 17 Internal resistance for sensor

Scan mode	R _{internal}
CTRLMUX	525 Ω
AMUXBUS	500 Ω

The value for C_p can be estimated using the CSD Built-in-Self-test APIs. See the [Component datasheet/middleware document](#) for details.

To minimize the scan time, as [Equation 61](#) shows, it is recommended to use the maximum sense clock frequency (F_{SW}) that satisfies the criteria as per [Equation 59](#).

$$T_{SCAN} = \frac{N_{Sub}}{F_{SW}}$$

Equation 61 Sensor scan time

Where,

N_{Sub} = Number of sub-conversions

Based on required sense clock frequency (F_{SW}), the sense clock divider be chosen per [Equation 62](#).

$$\text{Sense clock divider} = \frac{F_{MOD}}{F_{SW}}$$

Equation 62 Sense clock divider

[Equation 52](#) shows that it is best to use the maximum clock frequency to have a good gain ; however, you should ensure that the sensor capacitor fully charges and discharges as shown in [Figure 48](#). And keep in mind that higher clock frequency increases current consumption as there are more charging and discharging.

Generally, the C_p of the shield electrode will be higher compared to sensor C_p. For good liquid tolerance, the shield signal should satisfy the condition mentioned in [Tuning shield electrode](#) chapter . If it is not satisfied, reduce the sense clock frequency further to satisfy the condition.

Number of sub-conversions

The number of sub-conversions decides the sensitivity of the sensor and sensor scan time. From [Equation 19](#) for a fixed modulator clock and Sense clock, increasing the number of sub-conversions (N_{Sub}) increases the signal and SNR. However, increasing the number of sub-conversions also increases the scan time of the sensor per [Equation 63](#).

$$\text{Scan time} = \frac{N_{Sub}}{F_{SW}}$$

Equation 63 CSD-RM scan time

Initially, set the value to a low number, and use the Tuner GUI to find the SNR of the sensor. If the SNR is not > 5:1 with the selected , try to increase the in steps such that the SNR requirement is met.

Note: Number of sub-conversions should be greater than or equal to 8 to allow the CDAC dithering to function optimally. When using PRS/SSC it should be multiples of 1024 for optimal performance.

5 CAPSENSE™ performance tuning

Capacitive DACs

Fifth-Generation CAPSENSE™ supports two CDACs: Reference CDAC (C_{ref}) and Compensation CDAC (C_{comp}) that balance C_{MOD} 's as [Figure 44](#) shows. These govern the [Conversion gain and CAPSENSE™ signal](#) Conversion gain and CAPSENSE™ for capacitance-to-digital conversion. The CAPSENSE™ Component allows the following configurations of the CDACs:

- Enabling or disabling of Compensation CDACs
- Enabling or disabling of Auto-calibration for the CDACs
- Compensation CDAC divider, DAC code selection for Reference and Compensation CDACs if auto-calibration is disabled

Note: It is recommended to always enable auto-calibration for the CDADs. This will ensure optimal performance.

Reference CDAC (Cref)

The reference CDAC is used to compensate the charge transferred by the sensor self-capacitance (C_s) from C_{MOD} . The number of times it is switched depends on the self-capacitance of sensor. In case of finger placed over the sensor, additional reference CDAC switching is required to compensate.

C_{ref} should satisfy below criteria:

$$\text{RefCDACCode} > 6$$

Where,

$$C_{ref} = \text{Reference capacitance} = \text{RefCDACCode} * C_{lsb}$$

$$\text{RefCDACCode} = \text{Reference CDAC value}$$

$$C_{lsb} = 8.86 \text{ fF}$$

If the auto-calibrated RefCDACCode is less than 6, the following options can be used to increase the RefCDACCode,

- Decrease the sense clock divider. Note that the pulse width of the sense clock should be long enough to allow the sensor capacitance to charge and discharge completely. This decreased sense clock can be accommodated by decreasing series resistance or decreasing shield C_p .
- Disable compensation

Note: Tuning must be done such that this condition is satisfied across all units.

Compensation CDAC (Ccomp)

Enabling the compensation CDAC is called “dual CDAC” mode, and results in increased signal as explained in [Conversion gain and CAPSENSE™ signal](#). Enable the compensation CDAC for most cases.

The compensation capacitor is used to compensate excess self-capacitance from the sensor to increase the sensitivity. The number of times it is switched depends on the amount of charge the user application is trying to compensate (remove) from the sensor self-capacitance.

Compensation CDAC divider

The number of times the compensation capacitor is switched in a single sense clock is denoted by K_{comp} . Select CDAC compensation divider based on [Equation 60](#) such that below criteria is satisfied.

1. CDAC compensation divider ≥ 4
2. K_{comp} should be a whole number

5 CAPSENSE™ performance tuning

$$\text{CDAC compensation divider} = \frac{\text{Sense clock divider}}{K_{comp}}$$

Equation 64 **CDAC compensation divider**

Auto-calibration

The auto-calibration feature enables the firmware to automatically calibrate the CDAC to achieve the required calibration target of 85%. It is recommended to enable auto-calibration for most cases. Enabling this feature will result in the following:

- Fixed raw count calibration to 85% of maximum raw count even with part-to-part C_p variation
- Decrease the effect of [Flat-spots](#)

If your design environment includes large temperature variation, you may find that the 85% CDAC calibration level is too high, and that the raw counts saturate easily over large changes in temperature, leading to lower SNR. In this case, adjust the calibration level lower by using `Cy_CapSense_CalibrateAllSlots()` in your firmware. For proper functioning of CAPSENSE™ under diverse environmental conditions, it is recommended to avoid very low or high CDAC codes. For an 8-bit CDAC, it is recommended to use CDAC codes between 6-200 from the possible 0 to 255 range. You can use CAPSENSE™ tuner to confirm that the auto-calibrated CDAC values fall in this recommended range. If the CDAC values are out of the recommended range, based on [Equation 51](#), [Equation 52](#), and [Equation 54](#), you may change the Calibration level or *F_{mod}* or *F_{SW}* to get the CDAC code in proper range.

Selecting CDAC codes

This is not the recommended approach. However, this approach could be used only if you want to disable auto-calibration for any reason. To get the CDAC code, you may first configure CAPSENSE™ Component with auto-calibration enabled and all other hardware parameters the same as required for final tuning and read back the calibrated CDAC values using [Tuner GUI](#). Then, re-configure the CAPSENSE™ Component to disable auto-calibration and use the obtained CDAC codes as fixed DAC codes read-back from the [Tuner GUI](#).

CDAC dither

As the input capacitance is swept, the raw count should increase linearly with capacitance. There are regions where the raw count does not change linearly with input capacitance, and these are called flat-spots. See section [Flat-spots](#) for more details. Dithering helps to reduce flat-spots. This is done using a dither CDAC. The dither CDAC adds white noise that moves the conversion point around the flat region.

For details on setting dither related parameters, refer to the Readme of code example [PSoC™ 4: MSCLP CAPSENSE™ low power \(section 'Stage 2: Measure sensor capacitance to set CDAC Dither parameter'\)](#)

5.3.4.2.3 Tuning shield electrode

The shield related parameters need to be additionally configured or tuned differently when you enable the Shield electrode in the CSD-RM sensing method for liquid tolerance or reducing the C_p of the sensor.

5 CAPSENSE™ performance tuning

Shield electrode tuning theory

Ideally, the shield waveform should be exactly the same as that of the sensor as explained in CAPSENSE™ CSDRM shielding. However, in practical applications, the shield waveform may have a higher settling time. Observe the sensor and shield waveform in the oscilloscope; an example waveform is shown in Figure 88 and Figure 89. The shield waveform should settle to the sensor voltage within 90% of ON time of the sense clock waveform and the overshoot error of the shield signal with respect to VREF should be less than 10%.

If these conditions are not satisfied, you will observe a change in raw count of the sensors when touching the shield hatch; in addition, if inactive sensors are connected to shield as mentioned in Inactive sensor connection, touching one sensor can cause change in raw count on other sensors, which indicates that there is cross talk if the shield electrode is not tuned properly.

Approximate maximum shield frequency (F_{Shield}) which ensures correct charging and discharging of shield waveform can be calculated using Equation 65.

$$F_{Shield}(\text{maximum}) = \frac{1}{4 \times 5 \times R_{SeriesTotal} C_{sh}}$$

Equation 65 Sense clock maximum frequency

Where,

C_{sh} = Shield C_p

$R_{SeriesTotal} = R_{internal} + R_{EXT}$

R_{EXT} = External series resistor connected to shield electrode. Recommended value is 560 Ω .

$R_{internal}$ = Internal resistance, this varies based on scan and shield modes, see Table 18.

Table 18 Internal resistance for shield sensor

Scan Mode	$R_{internal}$ (Active Shield)	$R_{internal}$ (Passive Shield)
CTRLMUX	250 Ω	250 Ω
AMUXBUS	300 Ω	100 Ω

In SmartSense, the sense clock frequency is automatically set. Check if these conditions are satisfied. If not satisfied, switch to Manual tuning and set the sense clock frequency manually so that these conditions are satisfied.

5 CAPSENSE™ performance tuning

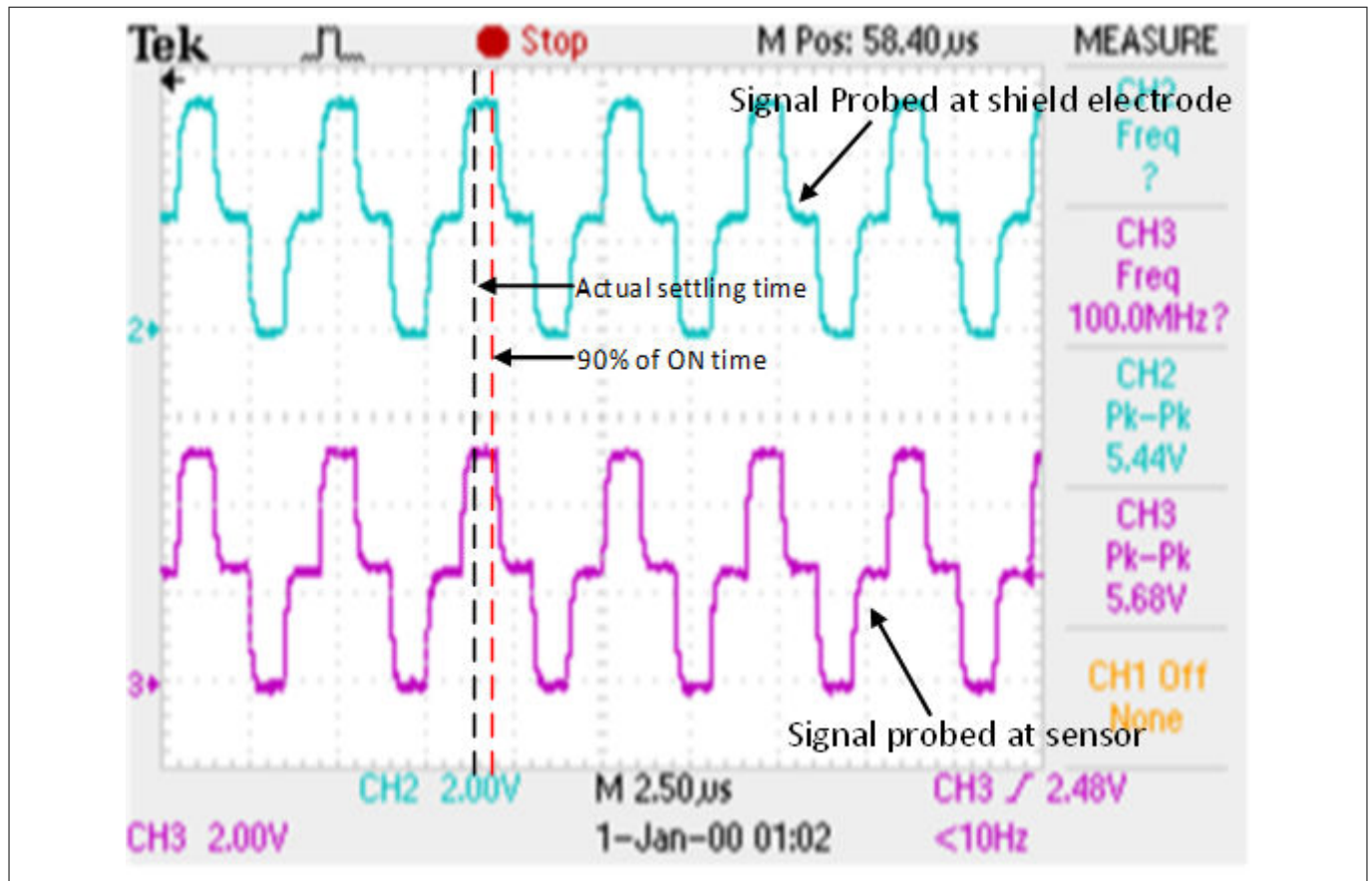

Figure 88 Properly tuned shield waveform (active shielding)

5 CAPSENSE™ performance tuning

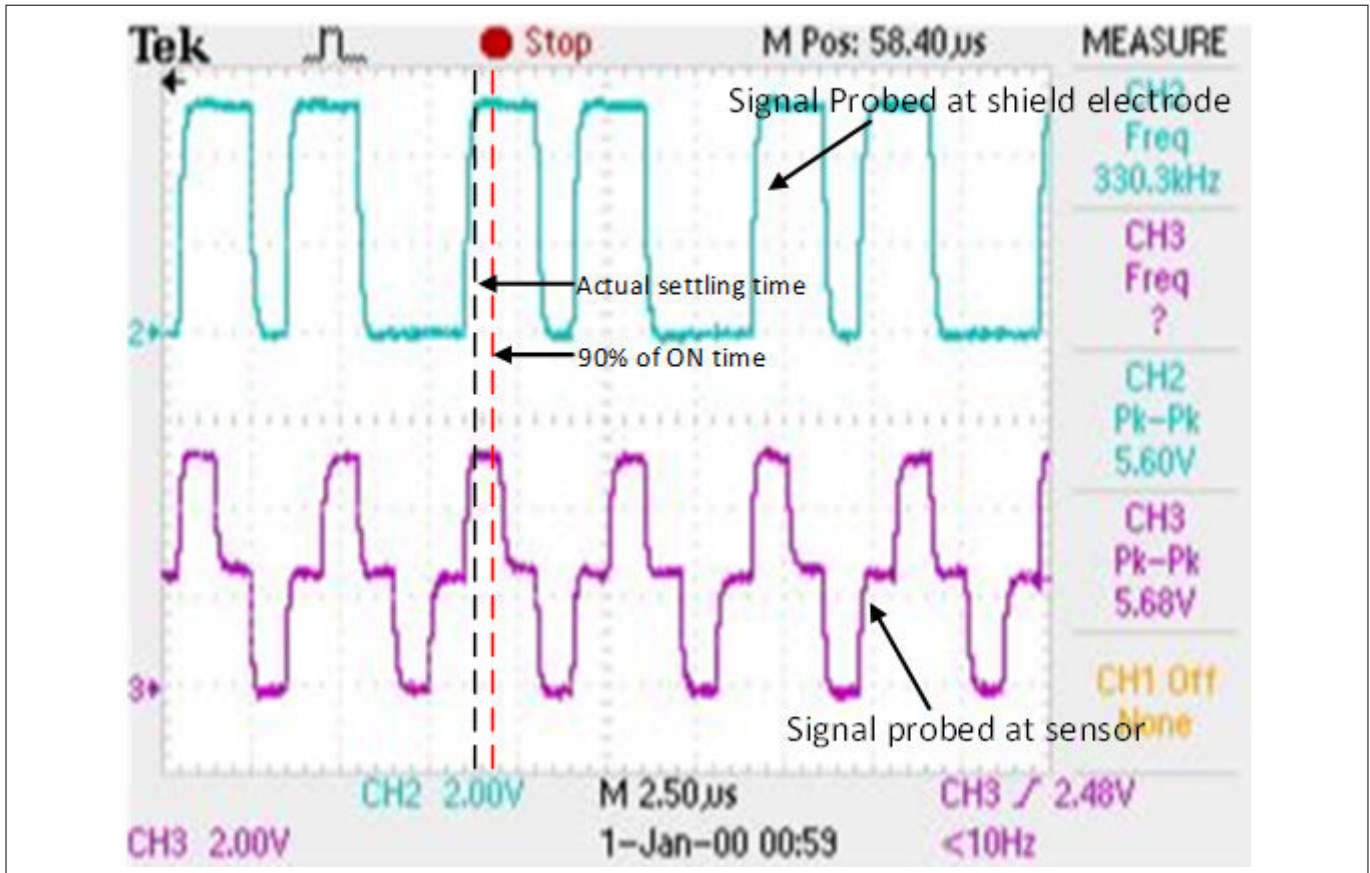

Figure 89 Properly tuned shield waveform (passive shielding)

Tuning shield-related parameters

Inactive sensor connection

When the shield electrode is enabled for liquid-tolerant designs, or if you want to use shield to reduce the sensor parasitic capacitance, this option should be specified as “Shield”; otherwise, select “Ground”. However, there is a risk of higher radiated emission due to inactive sensors getting connected to Shield. In such situations, use the CAPSENSE™ API to manually control inactive sensor connections. Instead of connecting all unused sensors to the shield, connect only the opposing inactive sensors or inactive sensors closer to the sensor being scanned to shield for reducing the radiated emission.

Number of shield electrodes (total shield count)

This parameter specifies the number of shield electrodes required in the design. Most designs work with one dedicated shield electrode; however, some designs require multiple dedicated shield electrodes for ease of PCB layout routing or to minimize the PCB real estate used for the shield layer. See [Layout guidelines for shield electrode](#) Layout guidelines for shield .

Shield mode

The Fifth-Generation CAPSENSE™ architecture supports two shield modes – active and passive shielding. See [CAPSENSE™ CSDRM shielding](#) section to decide which mode is best suited for your application.

5 CAPSENSE™ performance tuning

5.3.4.2.4 Selecting CAPSENSE™ software parameters

CAPSENSE™ software parameters in Fifth-Generation are the same as that for Fourth-Generation; therefore, these parameters could be selected as mentioned in [Selecting CAPSENSE™ software parameters](#) section.

5.3.4.2.5 Configuring autonomous scan

Autonomous scanning improves CPU offloading by removing the requirement of CPU intervention in between sensor scans. [Figure 90](#) shows the waveform of scanning all slots, which shows the CAPSENSE™ CPU bandwidth requirement for autonomous scanning and interrupt driven scanning. In autonomous scan once the CPU initiates a command to scan all slots, there is no CPU interrupt raised by CAPSENSE™ until all the slots are scanned. But in interrupt driven scan, after each slot scan, a CPU interrupt is raised to configure the next slot sensors.

5 CAPSENSE™ performance tuning

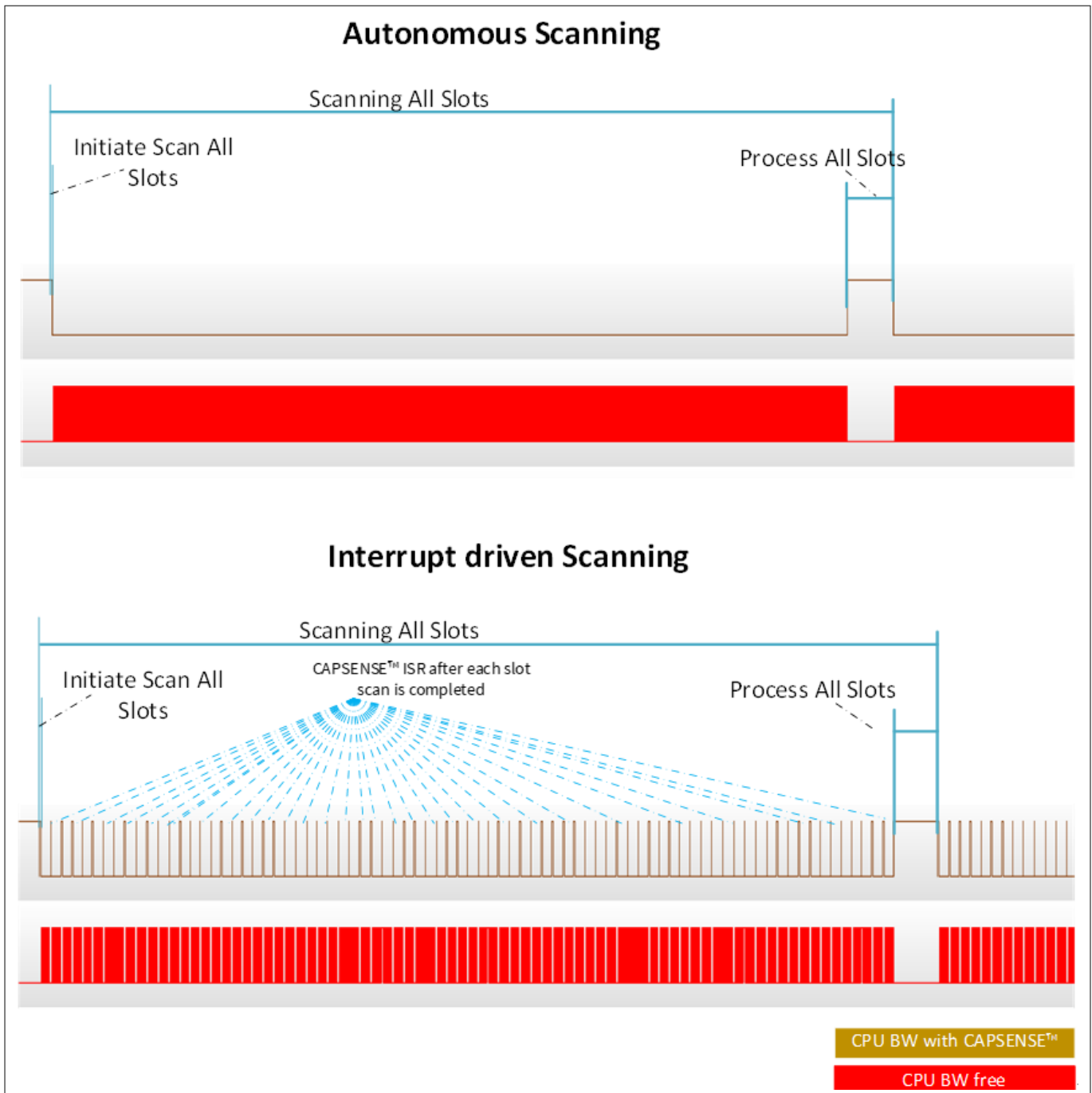

Figure 90 Autonomous Scanning versus Interrupt Driven Scanning

In fifth-generation CAPSENSE™, autonomous scanning is only available when Scan mode is set as Chained Scanning – DMA (CS-DMA) in the CAPSENSE™ configurator as shown in [Figure 91](#). And sensor connection method is only available as CTRLMUX. This limits the number of available CAPSENSE™ sensors. In Interrupt driven mode, sensor connection can be configured as either AMUXBUS or CTRLMUX. Through AMUXBUS any GPIO pin can be configured as a CAPSENSE™ sensor, but CPU interrupts need to be serviced to read the scan result and configure the next sensor.

5 CAPSENSE™ performance tuning

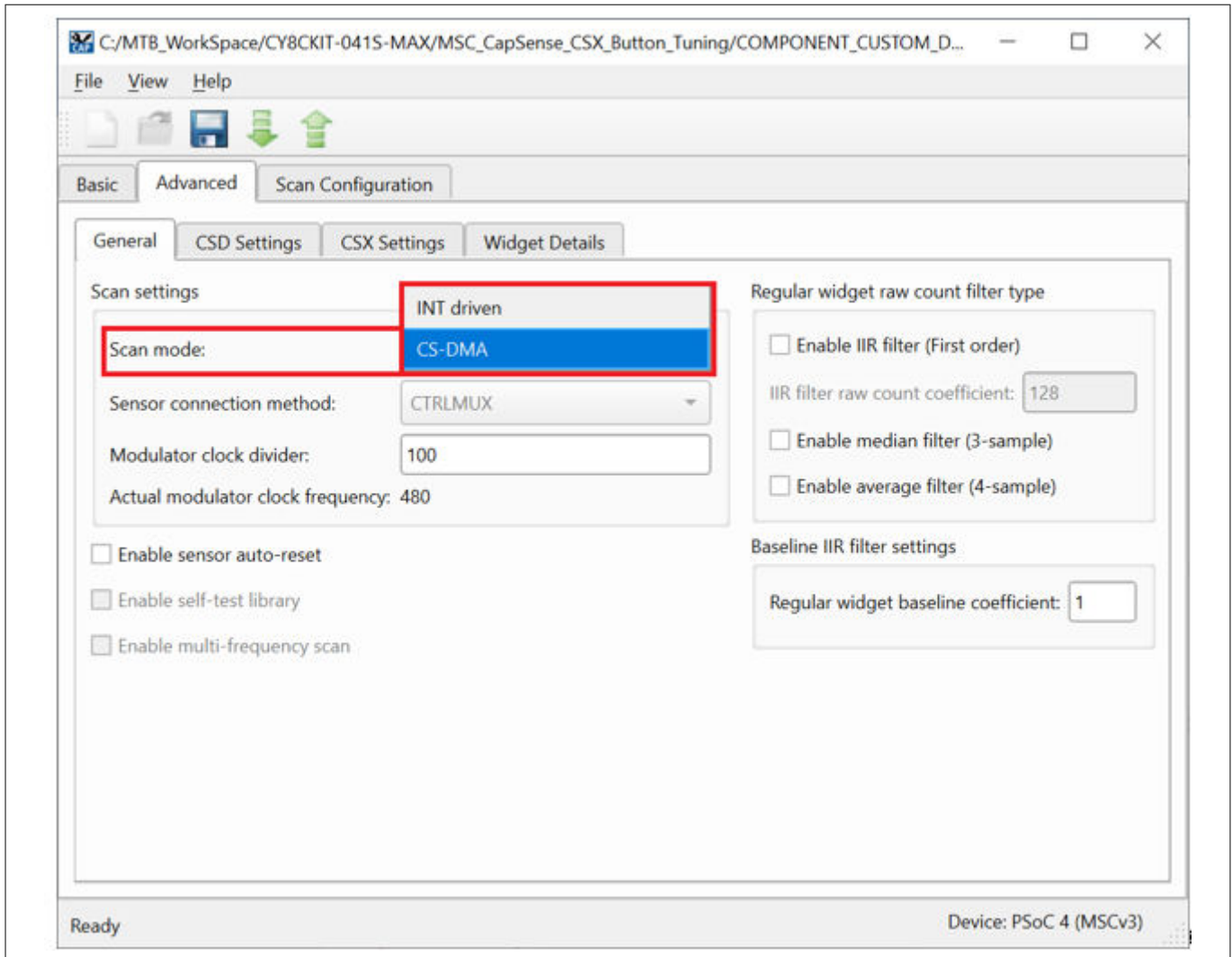

Figure 91 CAPSENSE™ configurator settings for scan mode

In fifth-generation low-powerCAPSENSE™ regular widgets are scanned autonomously by default. CPU can remain in deep sleep mode while the scanning happens. An interrupt can wake the CPU to process the data, after all the slots are scanned Low power widgets are scanned using the low-power always-on-sense (LP-AoS) mode as explained in [LP-AoS mode](#).

Autonomous scanning

Autonomous scanning mode in Fifth-Generation CAPSENSE™ technology avoids the CPU intervention for scanning every next sensor. This significantly reduces the CPU bandwidth required for scanning widgets with large number of sensors. Based on the CAPSENSE™ generation there are the following methods of autonomous scanning - [Chained scanning – DMA mode](#) and [LP-AoS mode](#).

Chained scanning – DMA mode

In the chained scanning - DMA mode, DMA handles the configuration of each sensor, thereby avoiding the requirement of CPU intervention after each sensor scan completion. Each channel of MSC block requires four channels of DMA to be configured in the device configurator as shown in [Figure 92](#).

5 CAPSENSE™ performance tuning

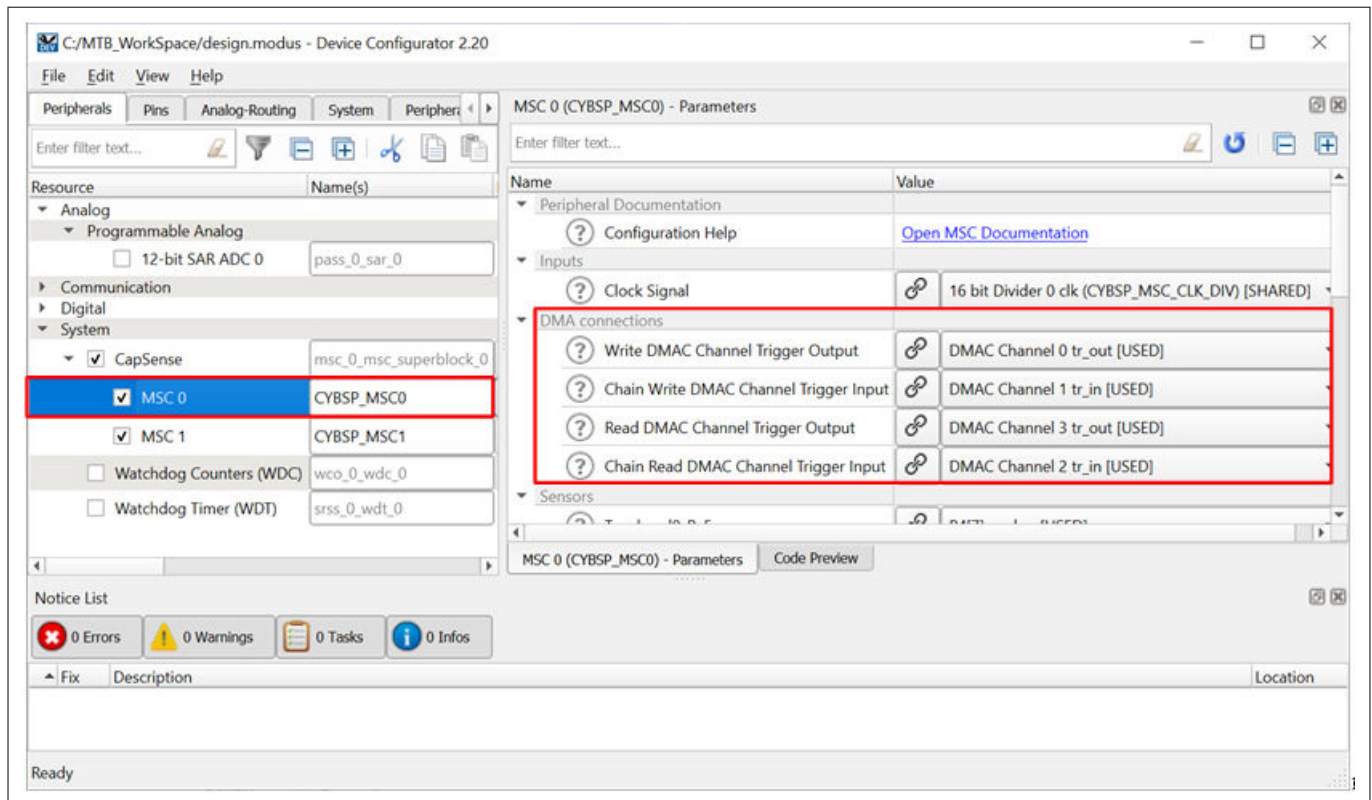

Figure 92 DMA configuration for MSC channels

Figure 93 illustrates the flow of CS-DMA based scanning mode.

1. Write DMA channel
Write DMA is configured to transfer scan configuration of a sensor to MSC block. Source address to the corresponding sensor’s scan configuration is received from Chain Write DMA channel
2. Chain Write DMA channel
When the MSC block completes scanning of current sensor, it will trigger the DMA to transfer the source address of next sensor’s or first sensor’s (if it is a new scan) scan configuration to the Write DMA channel
3. Read DMA channel
Read DMA channel transfer the scan result (rawcount) to destination location of corresponding sensor
4. Chain Read DMA channel
Once the current sensor scan is completed by MSC block, Chain Read DMA is triggered to transfer the destination location (address) of current sensor scan result (rawcount) to the Read DMA channel

5 CAPSENSE™ performance tuning

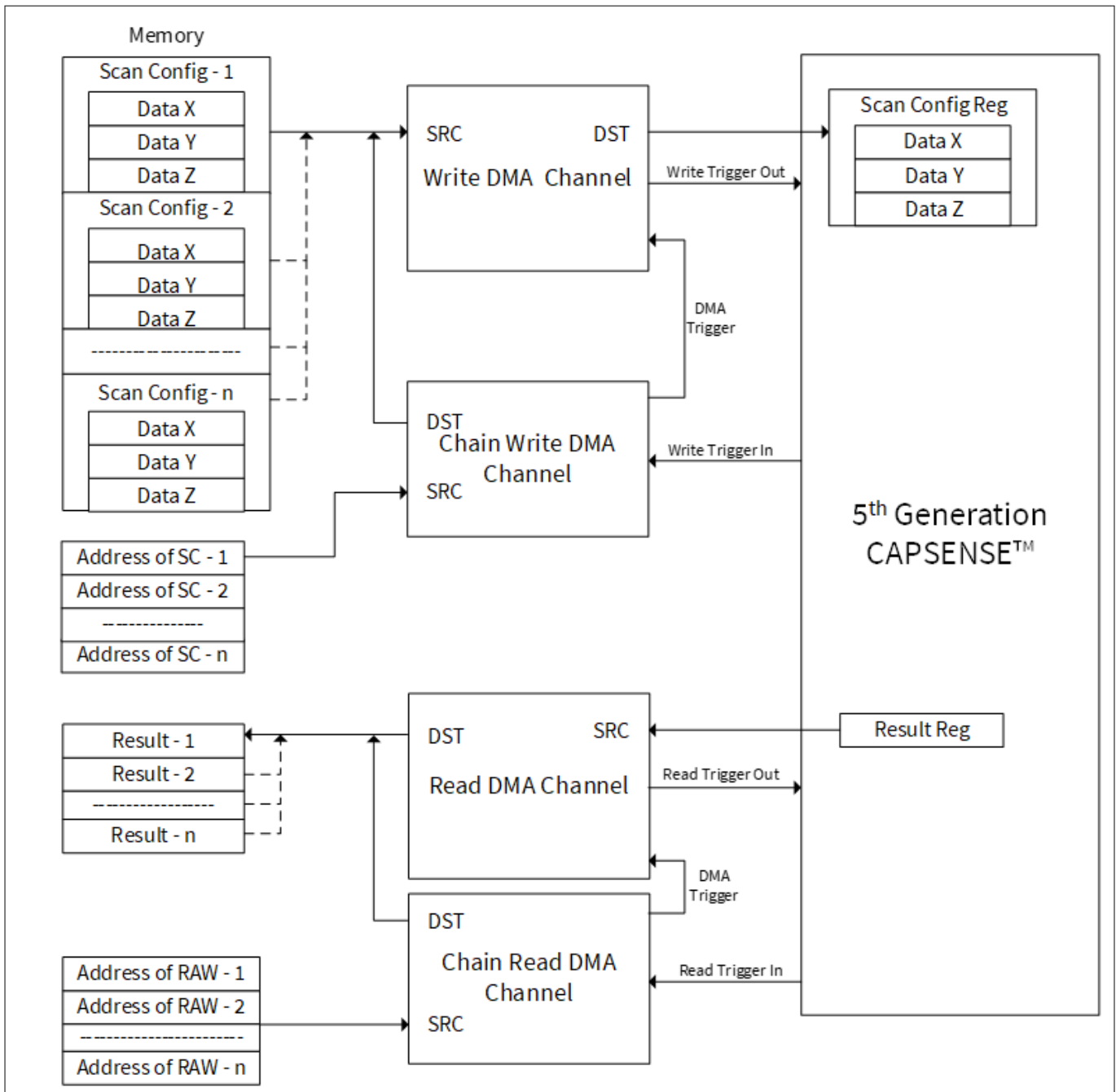

Figure 93 CS-DMA scanning flow

LP-AoS mode

The fifth-generation CAPSENSE (MSCLP) performs autonomous sensing using the LP-AoS hardware mode. Using this mode, multiple sensors (a frame) can be scanned without the intervention of the CPU. To enable this, the MSCLP block has an internal 1-KB SRAM. The middleware writes the configuration of multiple sensors to be scanned to the internal SRAM. Then, the MSCLP autonomously reads each sensor configuration, initiates scanning, and saves the result to the SRAM for the middleware to read and process after full-frame scanning is completed.

The device can be kept in any device power modes such as active, sleep, or deep sleep while MSCLP is scanning multiple sensors. MSCLP has all the system resources such as high-frequency clock and reference generator internal to the MSCLP hardware to enable scanning in device low-power state (i.e., deep sleep).

5 CAPSENSE™ performance tuning

Wake-on-Touch (WoT)

LP-AoS has the additional capability of scanning the same frame periodically and processing the result to detect touch. Therefore, the CPU is not required to process or initiate scanning; this allows the PSoC™ device to be kept in deep sleep for a longer time and to have the sensor touch detection as a wakeup interrupt. This is known as Wake-on-Touch. With this approach, the application can get the lowest power consumption with touch-sensing capability. Note that WoT is only supported for Low-Power Widgets. See section [Low-power widget tuning](#) for details on Low-Power Widgets.

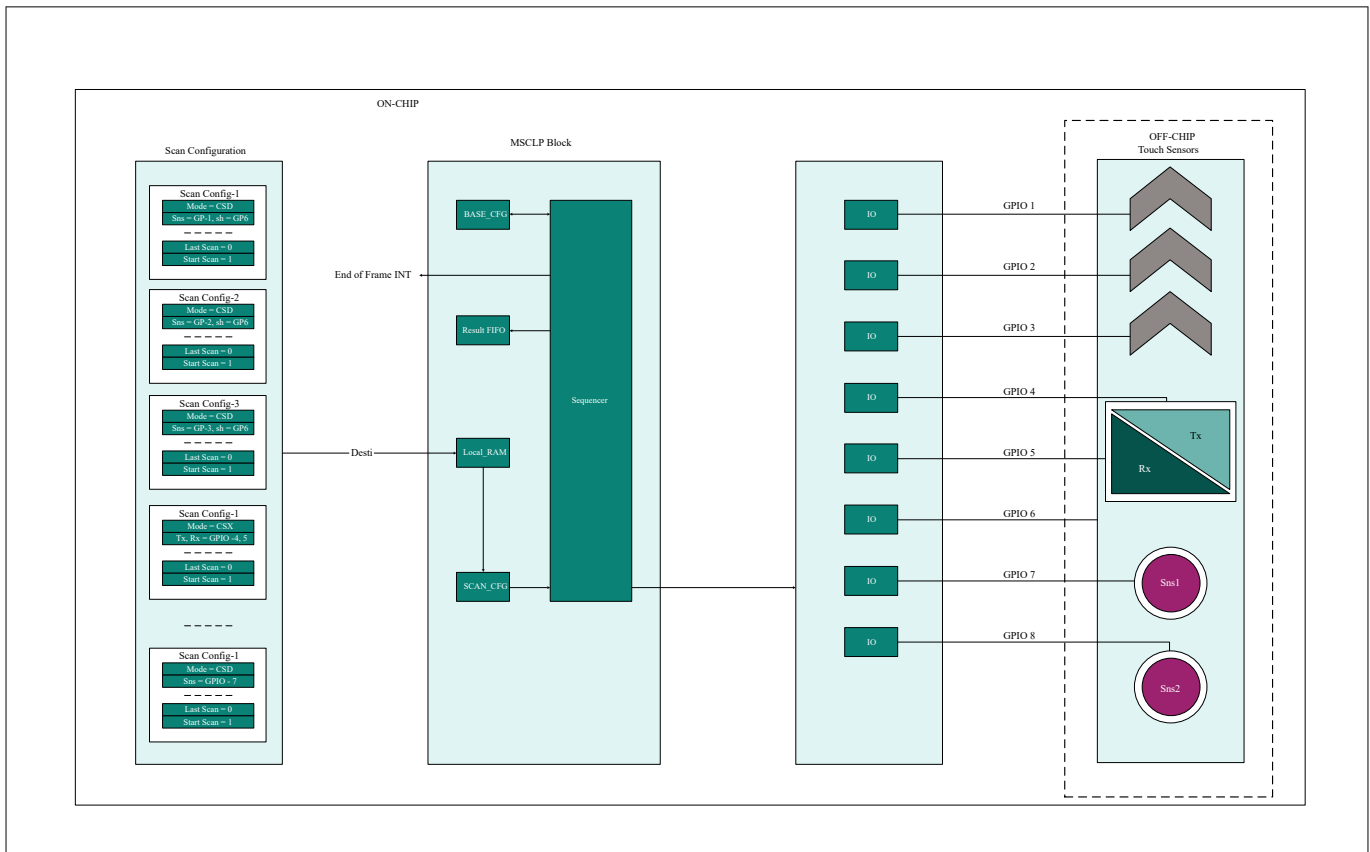

Figure 94 LP-AoS Mode

5.3.4.2.6 Multi-channel scanning

Multi-channel design uses both the instances of CAPSENSE™ MSC0 and MSC1, leading to simultaneous operation and reduction in scan time. Multi-channel scanning is in lock step thereby avoiding any cross-channel noise coupling. Scan synchronization is required to have the scanning in lock step. Fifth-Generation CAPSENSE™ technology has built in ability for multi-channel synchronization and CPU is not required for this. Multi-channel operation is an added advantage to support applications such as large touchpad, which require many sensor pins for interfacing. For example, a 6x8 touchpad can be configured as shown in [Figure 95](#). In this figure, the sensors shown in blue color is scanned by channel 0 (MSC0) and green color is scanned by channel 1 (MSC1).

5 CAPSENSE™ performance tuning

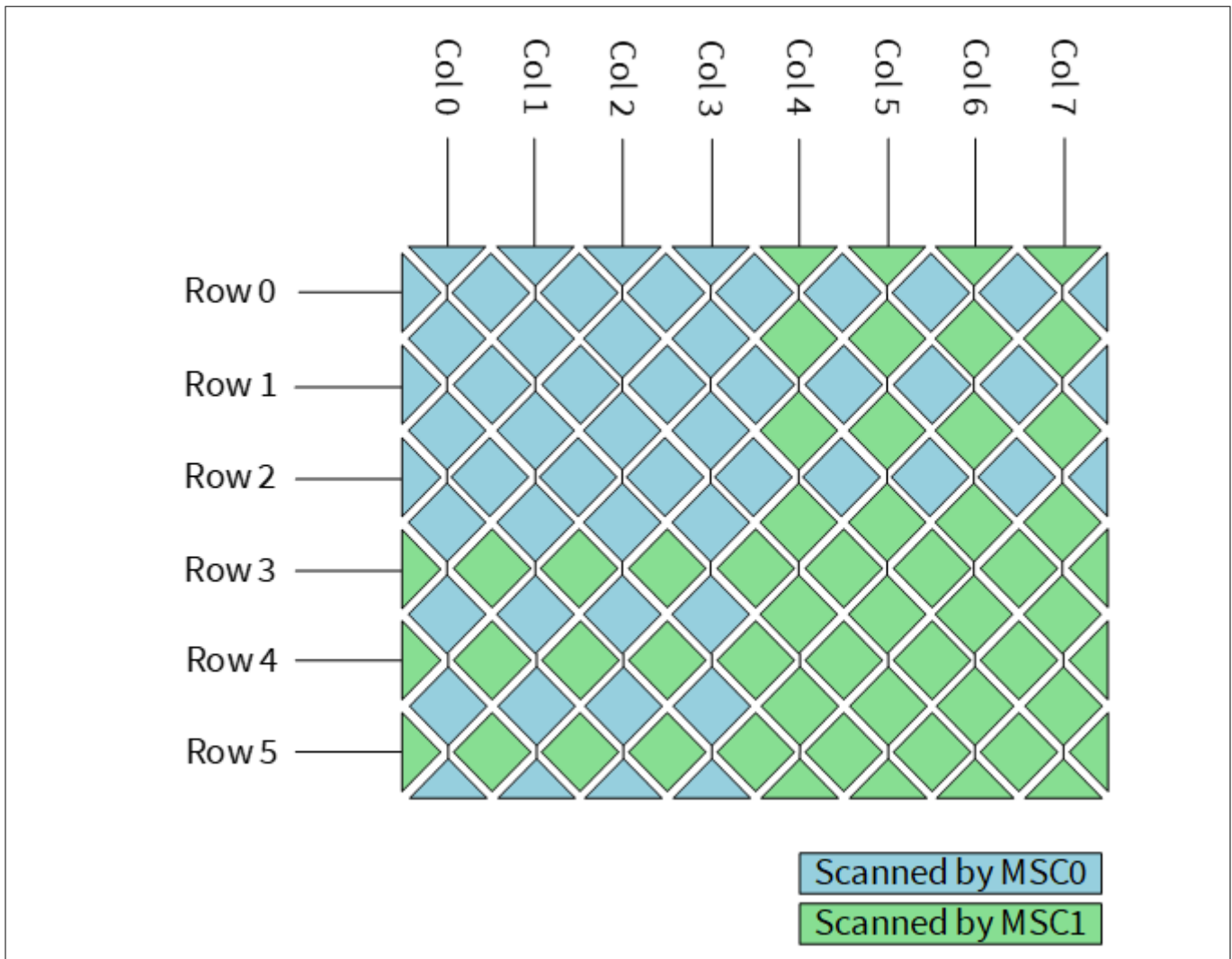

Figure 95 Scanning 6x8 CSD touchpad using multi-channel

In this case, channel 0 and channel 1 can scan one of its sensors at the same time. To avoid any cross-talk noise, sensors to be scanned together should be selected such that the physical distance between the two sensor is as maximum as possible, and should avoid combining row and column sensors.

In the above example, the recommended scan configuration is as shown in Table 19. All the sensors that belong to same slot is scanned together.

Table 19 Channel scan configuration

Slot #	Channel 0 sensor	Channel 1 sensor
Slot 0	Col 0	Col 4s
Slot 1	Col 1	Col 5
Slot 2	Col 2	Col 6
Slot 3	Col 3	Col 7
Slot 4	Row 0	Row 3
Slot 5	Row 1	Row 4
Slot 6	Row 2	Row 5

5 CAPSENSE™ performance tuning

5.3.4.2.7 Button widget tuning

Button widget tuning section provides high-level steps for tuning CSD button. The [CE231078 PSoC™ 4: MSC CAPSENSE™ CSD Button Tuning](#) explains tuning of self capacitance-based button widgets in the Eclipse IDE for ModusToolbox™. For details on the Component and all related parameters, see the [Component datasheet](#).

5.3.4.2.8 Slider widget tuning

Slider widget tuning section provides high-level steps for tuning CSD slider. The [CE232776 PSoC™ 4: MSC CAPSENSE™ CSD slider tuning](#) explains tuning of self-capacitance-based slider widgets in the Eclipse IDE for ModusToolbox™. For details on the Component and all related parameters, see the [Component datasheet](#).

5.3.4.2.9 Touchpad widget tuning

Touchpad widget tuning section provides high-level steps for tuning CSD-RM touchpad. The [CE235338 PSoC™ 4: MSCLP self-capacitance touchpad tuning](#) code example explains tuning of self capacitance-based touchpad widgets in the Eclipse IDE for ModusToolbox™. For details on the Component and all related parameters, see the [Component datasheet](#).

Following are the basic rules for the Scan Order tab for using the CSD-RM touchpad widget on multi-channels:

1. Scanning in fifth-generation CAPSENSE™ is ordered using slot numbers. A single slot number can be assigned to one sensor in all the channels and scanning that particular slot, scans all the sensors in that slot in sync
2. For CSD-RM touchpad, assign the same slot to the row or to the column in order to avoid scanning of a row and column element together, which causes cross-talk.
3. Assign slot numbers in such a way that there is a maximum distance between the sensors having the same slot number
4. Do not mix CSD and CSX sensors in a single slot
5. Divide the touchpad sensors equally between channels for optimizing scan duration
6. All channels must have equal number of sensors (scans) for a "consensus" method to work. If the number of sensors in each channel is not equal, "empty slots" are added to respective channels
7. Within a slot, all sensors should have the same sense clock and same number of sub-conversions

Figure 96 shows an example of slot configuration for an 8x6 CSD-RM touchpad.

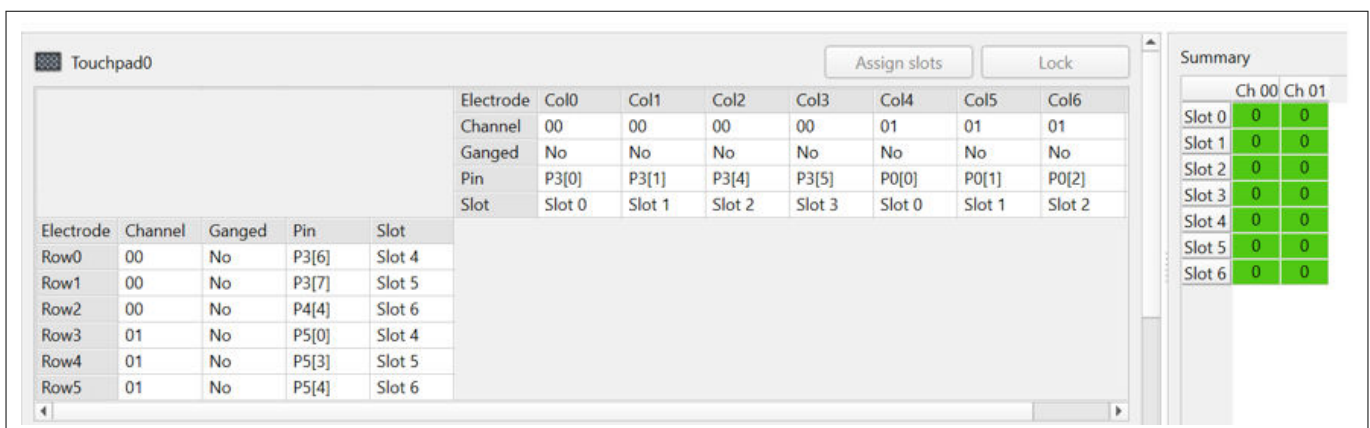

Figure 96 Slot configuration for an 8x6 CSD-RM touchpad

5.3.4.2.10 Proximity widget example

For tuning a proximity sensor, see [AN92239 - Proximity sensing with CAPSENSE™](#).

5 CAPSENSE™ performance tuning

5.3.4.2.11 Low-power widget tuning

The [CE235111 – PSoC™ 4: MSCLP CAPSENSE™ low power CSD Button Tuning](#) explains the tuning of a low-power widget in the Eclipse IDE for ModusToolbox™.

5.3.5 CSX-RM sensing method (fifth-generation and fifth-generation low-power)

This section explains the basics of manual tuning using the CSX-RM sensing method for the fifth-generation and fifth-generation low-power devices. It also explains the hardware parameters that influence the manual tuning procedure.

5.3.5.1 Basics

5.3.5.1.1 Conversion gain and CAPSENSE™ signal

Conversion gain influences how much signal count the system observes for a finger touch on the sensor. If there is more gain, the signal is higher, and a higher signal means a higher achievable [Signal-to-noise ratio \(SNR\)](#). Note that an increased gain may result in an increase in both signal and noise. However, if required, you can use firmware filters to decrease noise. For details on available firmware filters, see [Table 9](#).

Conversion gain in single CDAC

In a mutual-capacitance sensing system, the rawcount counter is directly proportional to the mutual-capacitance between the Tx and Rx electrodes, as [Equation 66](#) shows.

$$Rawcount_{counter} = G_{CSX}C_M$$

Equation 66 Raw count relationship to sensor capacitance

Where,

G_{CSX} = Capacitance to digital conversion gain of CAPSENSE™ CSX

C_M = Mutual-capacitance between the Tx and Rx electrodes

[Equation 34](#) shows the relationship between raw count and mutual-capacitance of the CSX sensor. The tunable parameters of the conversion gain in [Equation 67](#) are C_{ref} , $TxClk_{Div}$ and N_{Sub} .

The approximate value of this conversion gain is:

$$G_{CSX} = MaxCount \frac{2}{C_{ref}TxClk_{Div}}$$

Equation 67 Capacitance to digital converter gain

Where, $MaxCount = N_{Sub} * TxClk_{Div}$

The equation for raw count in the single CDAC mode, according to [Equation 66](#) and [Equation 67](#) is shown in [Equation 68](#).

$$Rawcount_{Counter} = N_{Sub} \frac{2 \times C_M}{C_{ref}}$$

Equation 68 Single CDAC mode raw counts

Where,

N_{Sub} = Number of sub-conversions

5 CAPSENSE™ performance tuning

$TxClk_{Div}$ = Tx clock divider

C_M = Sensor mutual-capacitance

RefCDACCode = Reference CDAC value

C_{Isb} = 8.86 fF

The tunable parameters of the conversion gain are C_{ref} , $TxClk_{Div}$, and N_{Sub} .

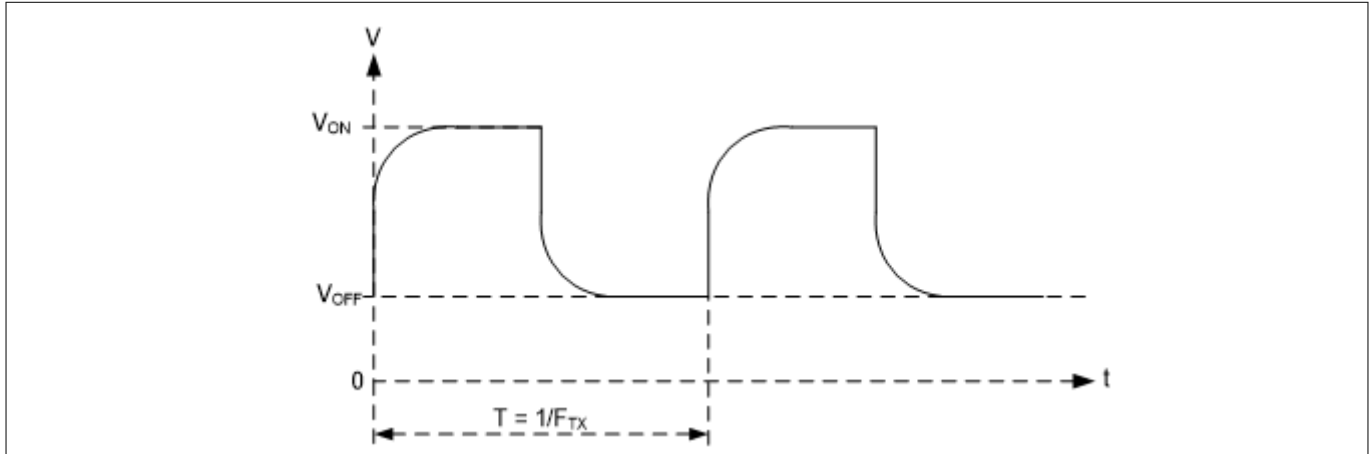

Figure 97 Voltage at Tx node of the CSX sensor

Note: The raw count observed from the Component is given by Equation 69. See CAPSENSE™ CSX-RM sensing method (fifth-generation and fifth-generation low-power) for more details on $Rawcount_{component}$.

$$Rawcount_{Component} = MaxCount - Rawcount_{Counter}$$

Equation 69 $Rawcount_{component}$

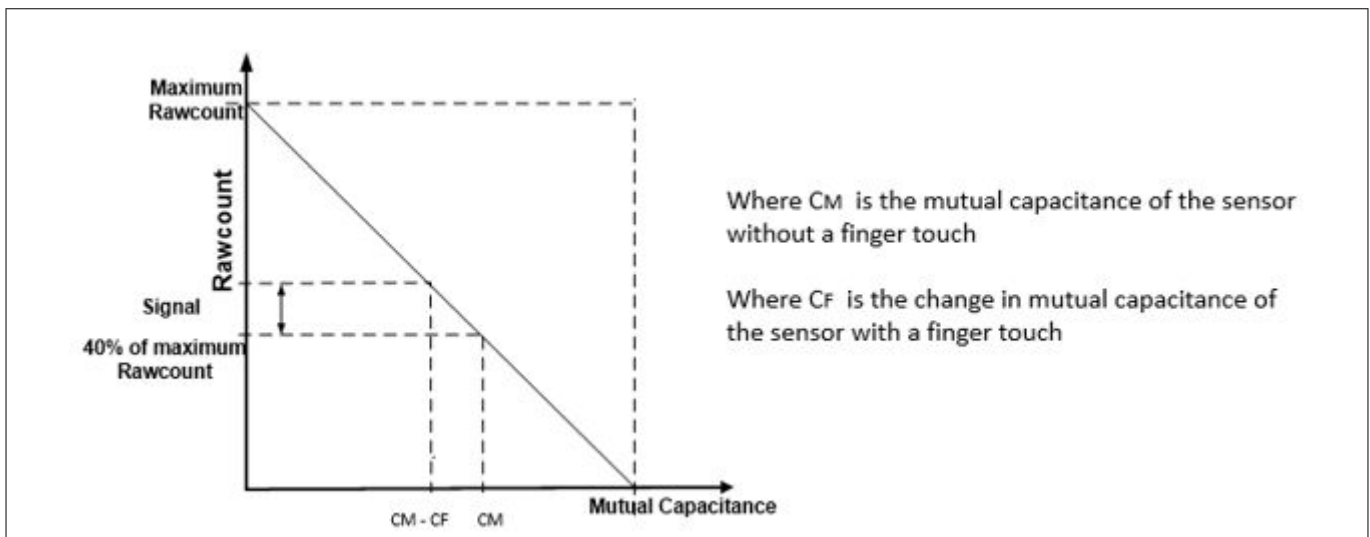

Figure 98 Raw count vs sensor mutual-capacitance

Conversion gain in dual CDAC mode

The equation for raw count in the dual CDAC mode, according to Equation 23 and Equation 66 is shown in Equation 70.

5 CAPSENSE™ performance tuning

$$\text{rawcount} = G_{CSX}C_M - \text{Maxcount} \frac{2 \times C_{comp}}{C_{ref} \text{CompCLK}_{div}}$$

Equation 70 Dual CDAC mode raw counts

Where,

$$\text{Maxcount} = N_{Sub} * \text{SnsClk}_{Div}$$

SnsClk_{Div} = Sense clock divider

N_{Sub} = Number of sub-conversions

C_{ref} = Reference capacitance = $\text{RefCDACCode} * C_{lsb}$

C_{comp} = Compensation capacitance = $\text{CompCDACCode} * C_{lsb}$

CompCLK_{Div} = CDAC compensation divider

C_M = Sensor mutual-capacitance

RefCDACCode = Reference CDAC value

CompCDACCode = Compensation CDAC value

C_{lsb} = 8.86 fF

G_{CSX} is given by [Equation 67](#)

5.3.5.2 Selecting CAPSENSE™ hardware parameters

CAPSENSE™ hardware parameters govern the conversion gain and CAPSENSE™ signal. [Table 20](#) lists the CAPSENSE™ hardware parameters that apply to the CSX-RM sensing method for the fifth-generation devices.

Table 20 CAPSENSE™ component hardware parameters

S. No	CAPSENSE™ parameter in ModusToolBox™
1	Tx clock divider
2	Tx clock source
3	Modulator clock divider
4	Reference CDAC value
5	CDAC compensation divider
6	Compensation CDAC value
7	Number of sub-conversions
8	Enable CDAC dither

5.3.5.2.1 Scan mode

Scan mode can be set as CS-DMA or Interrupt Driven mode. For autonomous scanning select DMA mode and for legacy interrupt based scanning select Interrupt Driven mode.

In fifth-generation low-power CAPSENSE™, autonomous scanning is supported inherently and does not need CPU intervention, and does not require CTRLMUX and DMA.

5.3.5.2.2 Sensor connection method

Autonomous scanning is only available in the CTRLMUX method, but the number of supported pins are limited in this method (see the [Device datasheet](#) for supported pins). Additionally, this method provides better

5 CAPSENSE™ performance tuning

immunity to on-chip I/O noise. Choose the AMUXBUS method to support more number of pins in the Interrupt Driven mode.

In the CTRLMUX connection method for CSX sensors, choose the inactive sensor connection as VDDA/2 and ensure to add empty scan slots before the first sensor scan for initializing the voltages on Rx lines to VDDA/2. See [Touchpad widget tuning](#) code examples for detailed steps on creating empty slots.

In fifth-generation low-power CAPSENSE™, all CAPSENSE™ pins support the autonomous scanning mode, via the AMUXBUS, compared to the limited number of pins, which were supported by the CTRLMUX in the fifth-generation CAPSENSE™ technology.

5.3.5.2.3 Modulator clock frequency

It is best to choose the highest allowed clock frequency for the given device because a higher modulator clock frequency leads to a higher sensitivity/signal, increased accuracy, and lower noise for a given C_M to digital count conversion as [Equation 66](#) and [Equation 67](#) indicates. Also, a higher value of F_{MOD}/F_{TX} ensures lower width of [Flat-spots](#) in C_M to raw count conversion.

5.3.5.2.4 Initialization sub-conversions

As part of initialization, C_{MODS} need to be charged at the required voltage (VDDA/2). There are three phases in initialization – C_{MOD} initialization, C_{MOD} short, and initialization sub-conversions. During the C_{MOD} initialization phase, C_{MOD1} is pulled to GND and C_{MOD2} is pulled to VDDA. During the C_{MOD} short phase, both capacitors are tied together so the charge is shared to produce a voltage close to VDDA/2 on both. After the two phases, the scanning is started but rawcount is discarded for a specific number of init sub-conversions.

Select the number of init sub-conversions based on [Equation 71](#).

$$\text{Number of init subconversions} = \text{ceiling}\left(\frac{C_{MOD} \times V_{OS}}{2 \times VDDA \times C_M \times (1 - \text{Base \%}) \times \left(\frac{1}{\text{Bal \%}} - 1\right)}\right) + 1$$

or

$$\text{Number of inti subconversions} = \text{ceiling}\left(\frac{C_{MOD} \times V_{OS}}{VDDA \times TxClkDiv \times C_{ref} \times (1 - \text{Bal \%})}\right) + 1$$

Equation 71 Number of init sub-conversions

Where,

C_{MOD} = Modulator capacitor

V_{OS} = Comparator offset voltage (3 mV of PSoC 4100S Max device)

Note: Use $V_{OS} = 4 \text{ mV}$ for Automotive grade (E-grade) devices

C_M = Sensor mutual-capacitance

Base% = Baseline compensation percentage

Bal% = Rawcount calibration percentage

C_{ref} = Reference capacitance = RefCDACCode * C_{lsb}

RefCDACCode = Reference CDAC value

C_{lsb} = 8.86 fF

5.3.5.2.5 Tx clock parameters

There are two parameters that are related to the Tx clock: Sense clock source and Sense clock frequency.

5 CAPSENSE™ performance tuning

Tx clock source

Select “Auto” as the clock source for the Component to automatically select the best Tx clock source between Direct and Spread Spectrum Clock (SSCx) for each widget. If the “Auto” option is not selected, then choose the clock source based on the following:

- Direct – Clock signal with a fixed-clock frequency. Use this option for most cases
- Spread spectrum clock (SSCx) – If you choose this option, the Tx clock signal frequency is dynamically spread over a predetermined range. Use this option for reduced EMI interference and avoiding flat-spots. However, when selecting the SSCx clock, ensure to select the Tx clock frequency, modulator clock frequency, and number of sub-conversions such that the conditions mentioned in [Component datasheet/ ModusToolbox CAPSENSE configurator guide](#) for the SSCx clock source selection are satisfied
- Pseudo Random Sequence (PRSt) – Use PRSt (pseudo random sequence) modes to remove flat-spots and improve EMI/EMC radiation and susceptibility. In 5th Generation CAPSENSE™, PRS clock introduces signal/sensitivity loss at higher rawcount calibration percent, hence 65% rawcount calibration is recommended when PRS clock is used

When selecting SSCx, you need to select the Sense clock frequency, Modulator clock frequency, and number of sub-conversions such that the conditions mentioned in the [ModusToolbox CAPSENSE configurator guide](#) for SSCx clock source selection are satisfied.

PRS/SSC can be used to reduce the emissions, but it increases power consumption as it needs high Nsubs. It is recommended to set Nsubs as 1024 (or multiples of 1024) to obtain the maximum spread. If Nsubs are lesser than 1024 or non-multiples of 1024, the performance will be non-optimal.

Tx clock frequency

The Tx clock frequency determines the duration of each sub-conversion as explained in the CAPSENSE™ CSX-RM sensing method (fifth-generation) section. The Tx clock signal must completely charge and discharge the sensor parasitic capacitance; and can be verified by checking the signal in an oscilloscope or it can be set using [Equation 66](#). In addition, ensure that the auto-calibrated CDAC code lies in the mid-range (for example, 6-200) for the selected . If the auto-calibrated CDAC code lies out of the recommended range, tune such that it falls in the recommended range and satisfies [Equation 72](#).

$$F_{TX} < \frac{1}{2 \times 5 \times R_{SeriesTx} C_{PTx}}$$

Equation 72 Condition for selecting Tx clock frequency

Where,

C_{pTx} = Tx electrode parasitic capacitance

R_{SeriesTx} = Total series-resistance, including the R_{internal} resistance of the internal switches, the recommended external series resistance of 2 KΩ (connected on PCB trace connecting sensor pad to the device pin), and trace resistance if using highly resistive materials (example ITO or conductive ink).

R_{internal} = Internal resistance, this varies based on scan modes, see [Table 21](#).

Table 21 Internal resistance for sensor

Scan mode	R _{internal}
CTRLMUX	950 Ω
AMUXBUS	500 Ω

The value for C_p can be estimated using the CSD Built-in-Self-test APIs. See the [Component datasheet/ middleware document](#) for details.

5 CAPSENSE™ performance tuning

To minimize the scan time, as [Equation 73](#) shows, it is recommended to use the maximum Tx clock frequency available in the component drop-down list that satisfies [Equation 72](#).

$$T_{CSX} = \frac{N_{Sub}}{F_{TX}}$$

Equation 73 Scan time of CSX sensor

Where,

N_{Sub} = [Number of sub-conversions](#)

Additionally, if you are using the SSCx clock source, ensure that you select the Tx clock frequency that meets the conditions mentioned in [Component datasheet/middleware document/ModusToolbox CAPSENSE™ configurator guide](#) in addition to these conditions.

5.3.5.2.6 Number of sub-conversions

The number of sub-conversions decides the sensitivity of the sensor and sensor scan time. From [Equation 24](#) for a fixed modulator clock and Tx clock, increasing the number of sub-conversions (N_{Sub}) increases the signal and SNR. However, increasing the number of sub-conversions also increases the scan time of the sensor per [Equation 73](#).

Initially, set the value to a low number (for example, 20), and use the Tuner GUI to find the SNR of the sensor. If the SNR is not > 5:1 with the selected N_{Sub} , increase then N_{Sub} in steps such that the SNR requirement is met.

Note: Number of sub-conversions should be greater than or equal to 8 to allow the CDAC dithering to function optimally. When using PRS/SSC it should be multiples of 1024 for optimal performance.

5.3.5.2.7 Capacitive DACs

In the fifth-generation technology, CSX-RM supports two CDACs: Reference CDAC (C_{ref}) and Compensation CDAC (C_{comp}), that balance C_{MODS} as [Equation 8](#) shows. These govern the Conversion gain and CAPSENSE™ signal for capacitance-to-digital conversion. The CAPSENSE™ Component allows the following configurations of the CDACs:

- Enabling or disabling of Compensation CDACs
- Enabling or disabling of Auto-calibration for the CDACs
- Compensation CDAC divider, DAC code selection for Reference and Compensation CDACs if auto-calibration is disabled

Note: It is recommended to always enable auto-calibration for the CDADs because this ensures optimal performance.

Reference CDAC (C_{ref})

The reference CDAC is used to compensate the charge transferred by the sensor mutual-capacitance (C_M) from C_{MOD} . The number of times it is switched depends on the mutual-capacitance of the sensor.

C_{ref} should satisfy the following criteria:

$$RefCDACCode > 6$$

Where,

$$C_{ref} = \text{Reference capacitance} = RefCDACCode * C_{lsb}$$

RefCDACCode = Reference CDAC value

$$C_{lsb} = 8.86fF$$

5 CAPSENSE™ performance tuning

Note: Tuning must be done such that this condition is satisfied across all units.

Compensation CDAC (C_{comp})

Enabling the compensation CDAC is called “dual CDAC” mode, and results in increased signal as explained in [Conversion gain and CAPSENSE™ signal](#). Enable the compensation CDAC for most cases.

The compensation capacitor is used to compensate excess mutual-capacitance from the sensor to increase the sensitivity. The number of times it is switched depends on the amount of charge the user application is trying to compensate from the sensor mutual-capacitance.

5.3.5.2.8 Compensation CDAC divider

The number of times the compensation capacitor is switched in a single sense clock is denoted by K_{comp} . Select CDAC compensation divider based on below [Equation 74](#) such that below criteria is satisfied:

1. CDAC compensation divider ≥ 4
2. K_{comp} should be a whole number

$$\text{CDAC compensation divider} = \frac{\text{Tx clock divider}}{K_{comp}}$$

Equation 74 CDAC compensation divider

5.3.5.2.9 Auto-calibration

This feature enables the firmware to automatically calibrate the CDAC to achieve the required calibration target of 40%. It is recommended to enable auto-calibration for most cases. Enabling this feature will result in the following:

Fixed raw count calibration to 40% of max raw count even with part-to-part C_M variation

Decrease the effect of [Flat-spots](#)

Automatically selects the optimum gain

For proper functioning of CAPSENSE™ under diverse environmental conditions, it is recommended to avoid very low or high CDAC codes. You can use CAPSENSE™ tuner to confirm that the auto-calibrated CDAC values fall in this recommended range. If the CDAC values are out of the recommended range, based on [Equation 66](#), [Equation 67](#), and [Equation 69](#), you may change the Calibration level or F_{mod} or F_{SW} to get the CDAC code in proper range.

5.3.5.2.10 Selecting CDAC codes

This is not the recommended approach. However, this could be used only if you want to disable auto-calibration for any reason. To get the CDAC code, you may first configure CAPSENSE™ Component with auto-calibration enabled and all other hardware parameters the same as required for final tuning and read back the calibrated CDAC values using [Tuner GUI](#). Then, re-configure the CAPSENSE™ Component to disable auto-calibration and use the obtained CDAC codes as fixed DAC codes read-back from the [Tuner GUI](#).

5.3.5.2.11 CDAC dither

As the input capacitance is swept, the raw count should increase linearly with capacitance. However, there are regions called flat-spots where the raw count does not change linearly with input capacitance (refer to section [Flat-spots](#) for more details). Dithering, with the help of a dither CDAC, helps to reduce flat-spots. The dither CDAC adds white noise that moves the conversion point around the flat region.

5 CAPSENSE™ performance tuning

For details on setting dither related parameters, refer to the [PSoC™ 4: MSCLP CAPSENSE™ low power \(section 'Stage 2: Measure sensor capacitance to set CDAC Dither parameter'\)](#) code example.

5.3.5.2.12 Fine CDAC

5.3.5.3 Selecting CAPSENSE™ software parameters

CAPSENSE™ software parameters in the fifth-generation are the same as that for fourth-generation; therefore, these parameters can be selected as mentioned in the [Selecting CAPSENSE™ software parameters](#) section.

5.3.5.4 Configuring autonomous scan

Configuring autonomous scan in CSX-RM sensing is the same as that for CSD-RM sensing; therefore, configure autonomous scan as mentioned in the [Configuring autonomous scan](#) section.

5.3.5.5 Multi-channel scanning

Multi-channel scanning in CSX-RM sensing is the same as that for CSD-RM sensing; therefore, refer to the [Chapter 5.3.4.2.6](#) section for more details.

5.3.5.6 Button widget tuning

[Button widget tuning](#) section provides high-level steps for tuning CSX button. The [CE231079 PSoC™ 4: MSC CAPSENSE™ CSX button tuning](#) explains tuning of mutual-capacitance based button widgets in the Eclipse IDE for ModusToolbox™. For details on the Component and all related parameters, see the [Component datasheet](#).

5.3.5.7 Touchpad widget tuning

Refer to [AN234185 PSoC™ 4 CAPSENSE™ Touchpad design guide](#) for touchpad tuning guidelines.

5.3.6 Manual tuning trade-offs

When manually tuning a design, it is important to understand how the settings impact the characteristics of the capacitive sensing system. Any CAPSENSE™ design has three major performance characteristics: reliability, power consumption, and response time.

- **Reliability** defines how CAPSENSE™ systems behave in adverse conditions such as a noisy environment or in the presence of water. High-reliability designs will avoid triggering false touches, and ensure that all intended touches are registered in these adverse conditions

Power consumption is defined as the average power drawn by the device, which includes, scanning, processing, and low-power mode transitions as explained in [Low-power design](#). Quicker scanning and processing of the sensors ensures that the device spends less time in a higher power state and maximizes the time it can spend in a lower power sleep state.

- **Response time** defines how much time it takes from the moment a finger touches the sensor until there is a response from the system. Because the lowest response time is limited by the scan and processing time of the sensors, it is important to properly define and follow a timing budget. A good target for total response time is below 100 ms

These performance characteristics depend on each other. The purpose of the tuning process is to find an optimal ratio that satisfies the project's specific requirements. When planning a design, it is important to note

5 CAPSENSE™ performance tuning

that these characteristics usually have an inverse relationship. If you take action to improve one characteristic, the others will degrade.

For example, if you want to use CAPSENSE™ in a toy, it is more important to have a quick response time and low power consumption. In a different example, such as a “Start/Stop” button for an oven, reliability is the most important characteristic and the response time and power consumption are secondary.

Now let us consider the factors that affect reliability, power consumption, and response time. Figure 99 shows dependencies between CAPSENSE™ characteristics, measurable parameters, and actual CAPSENSE™ configurable parameters.

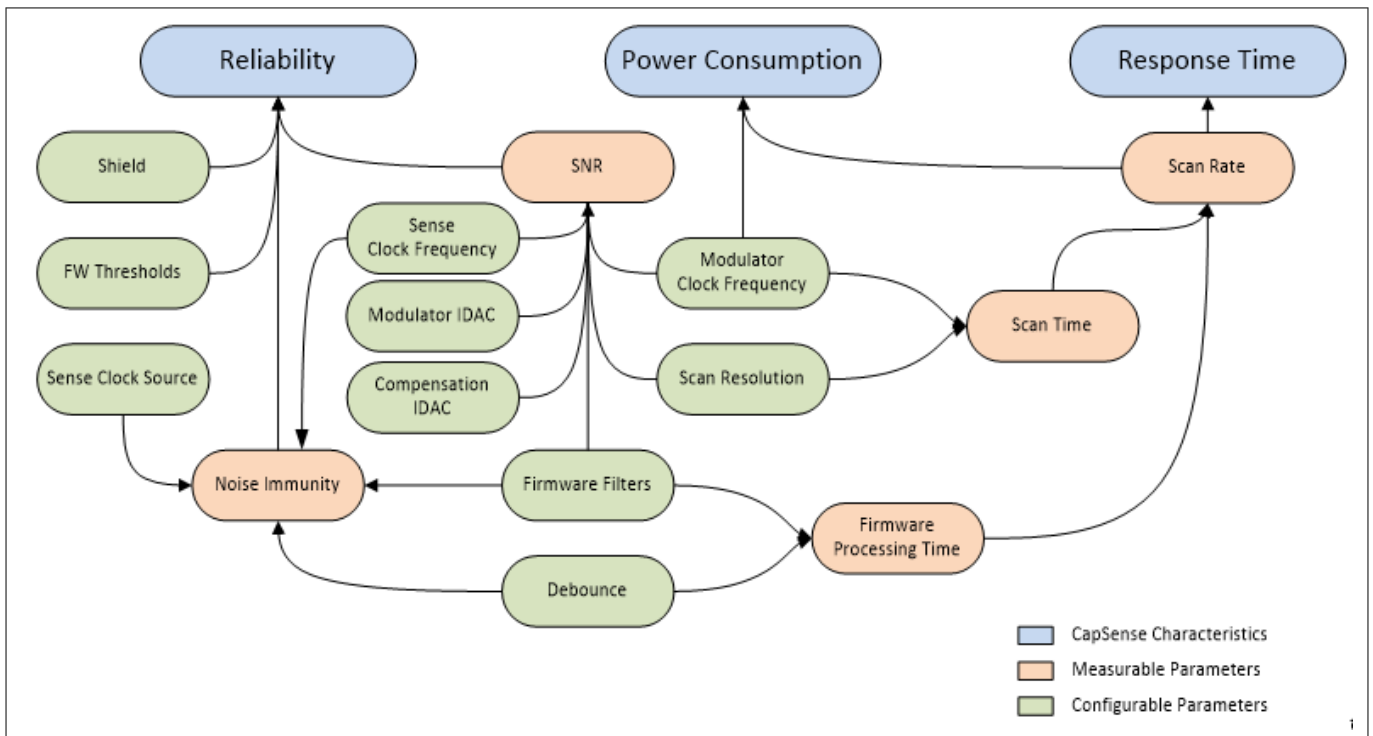

Figure 99 CAPSENSE™ parameter relationships

5.3.6.1 Reliability

The following factors affect reliability:

1. **Signal-to-noise ratio (SNR):** SNR gives a measure of confidence in a valid touch signal. For reliable CAPSENSE™ operation, it should be greater than 5. Manual tuning can ensure optimal SNR in specific designs
2. **Noise immunity:** It is the ability of the system to resist external or internal noise. Typical examples of external noise are ESD events, RF transmitters such as Bluetooth® LE, switching relays, power supply, and so on. The internal noise source could be an LED driven by PWM, or I²C, or SPI communications for example. Even designs with good SNR may suffer from poor performance because of poor noise immunity. Manual tuning allows to tune frequencies and parameters to help avoid noise interference by allowing more control over selection of different parameters

5.3.6.2 Power consumption and response time

The following factors affect the power consumption and response time:

1. **Scan rate:** Scan rate can be defined as the frequency at which you scan the sensor. Scan rate decides the minimal possible time from the finger touch until it is reported. The maximum scan rate will be limited by the [Sensor scan](#)

5 CAPSENSE™ performance tuning

2. Scan time: It is the time taken to scan and process a particular sensor. It affects power consumption as indicated in [Low-power design](#) and scan rate as indicated above. Manual tuning can achieve specific scan durations while maintaining a minimum SNR
3. Firmware touch delay: This can be caused by the [Debounce](#) procedure or use of Raw Data Noise Filters (depending on the CAPSENSE™ component version you are using). Both affect scan time by adding to the processing time of a sensor and delay the touch reporting until a certain number of samples in a row show the touch signal. In both cases response rate is reduced, but reliability is usually improved

5.3.7 Tuning debug FAQs

This section lists the general debugging questions on CAPSENSE™ Component tuning. Jump to the question you have, for quick information on possible causes and solutions for your debugging topic.

5.3.7.1 The tuner does not communicate with the device

Cause 1: Your device is not programmed.

Solution 1: Make sure to [Program](#) your device with your latest project updates before launching the tuner.

Cause 2: The tuner configuration setting does not match the SCB Component setting.

Solution 2: Open the EzI2C slave component configuration window, that is, the Configure 'SCB_P4' dialog and verify that the settings match the configuration of the Tuner Communication Setup dialog. See the [CAPSENSE™ Component datasheet](#) for details on tuner usage.

Cause 3: Your I2C pins are not configured correctly.

Solution 3: Open the `.cydwr` file in Workspace Explorer and ensure the pin assignment matches what is physically connected on the board.

Cause 4: You did not include the CAPSENSE™ TunerStart API or another required tuner code.

Solution 4: Add the tuner code listed in [CAPSENSE™ Component](#) datasheet to your main.c and reprogram the device.

5.3.7.2 I am unable to update parameters on my device through the tuner

Cause 1: Your communications settings on the device are incorrect.

Solution 1: Review and make sure the settings in the UART/EZIC configurator dialog and Tuner Communication Setup dialog match. Make sure that the sub-address size is equal.

5.3.7.3 I can connect to the device but I do not see any raw counts

Cause 1: You did not add the tuner code to your project.

Solution 1: Review the [Tuner GUI](#) section and add the tuner code to your main.c and reprogram the device.

5.3.7.4 Difference counts only change slightly (10 to 20 counts) when a finger is placed on the sensor

Cause 1: The gain of your system is too low.

Solution 1: Review the [Tuner GUI](#) section of this document.

Cause 2: Your sensor parasitic capacitance is very high.

Solution 2: To confirm this issue, use the Built-in Self-Test (BIST) APIs documented in the [Component datasheet](#). These functions allow you to read out an estimate of the sensor parasitic capacitance. You can also confirm this reading independently with an LCR meter.

5 CAPSENSE™ performance tuning

If your hardware has an option to enable [Driven shield signal and shield electrode](#), use this option in the advanced settings of the CAPSENSE™ Component configuration window. A driven shield around the sensors helps reduce the parasitic capacitance. When you enable this option, you may want to enable driving the shield to unused sensors by also changing the “Inactive Sensor connection” setting to “shield” in the advanced settings. If after enabling the shield, your C_p remains greater than the supported range of parasitic capacitance by the PSoC™ device, review your board layout to reduce C_p further, by following the PCB layout guidelines, and/or contact [Technical support](#) to review your layout. See [Component datasheet/middleware document](#) for more details on the supported range of C_p .

Cause 3: Your overlay may be too thick.

Solution 3: Review your [Overlay thickness](#) with respect to your [Overlay thickness](#).

Cause 4: Raw counts may be too close to saturation and hence, saturating when sensor is touched.

Solution 4: Tune IDAC to ensure that raw counts are tuned to ~85 percent of the max raw count for a given sensor according to the [Modulation and compensation IDACs](#) section.

5.3.7.5 After tuning the system, I see large amount of radiated noise during testing

Cause 1: The sense clock frequency is causing radiated noise in your system.

Solution 1: Reduce the sense clock frequency or enable PRS for your sensor based on [Electromagnetic compatibility \(EMC\) considerations](#) section. If it is already enabled, see the [Electromagnetic compatibility \(EMC\) considerations](#) section.

Cause 2: Large shield electrode may be contributing to a large radiated noise.

Solution 2: Reduce the size of shield electrode based on [Layout guidelines for liquid tolerance](#).

5.3.7.6 My scan time no longer meets system requirements after manual tuning

Cause: The noise and C_p of your system are high, which requires more scan time and filtering to achieve reliable operation.

Solution: C_p needs to be reduced. First, enable the [Driven shield signal and shield electrode](#) in the advanced settings of the CAPSENSE™ Component configuration window and ensure gain is set as high as possible by reviewing the [PCB layout guidelines](#). If your system still cannot meet final requirements, you may need to change your board layout to reduce C_p further, review the [PCB layout guidelines](#) for the same.

5.3.7.7 I am unable to calibrate my system to 85 percent

Cause 1: Your sensor may have a short to ground.

Solution: First, use a multimeter to check if there is a short between your sensor and ground. If it is present, review your schematic and layout for errors.

Cause 2: Your sensor C_p may be too high or too low.

Solution: If your hardware has an option to enable [Driven shield signal and shield electrode](#), use this option in the advanced settings of the CAPSENSE™ Component configuration window. A driven shield around the sensors helps reduce the parasitic capacitance. If you do not have a hardware option to use shield or if after enabling the shield, your C_p remains greater than the device supported C_p , contact [Technical support](#) to review your layout or for further application-specific guidance.

If you suspect the capacitance to be low compared to the minimum supported parasitic capacitance by the device, add a footprint of the capacitor to a pin. In the final design, if the C_p is identified to be lower than the supported range, place an additional compensation capacitor to increase the sensor C_p to the supported range by dynamically connecting it to the sensor while scanning. See the [Component datasheet/middleware](#)

5 CAPSENSE™ performance tuning

document to understand how to gang the sensors to an external compensation capacitor connected to a pin to increase the C_p whenever required.

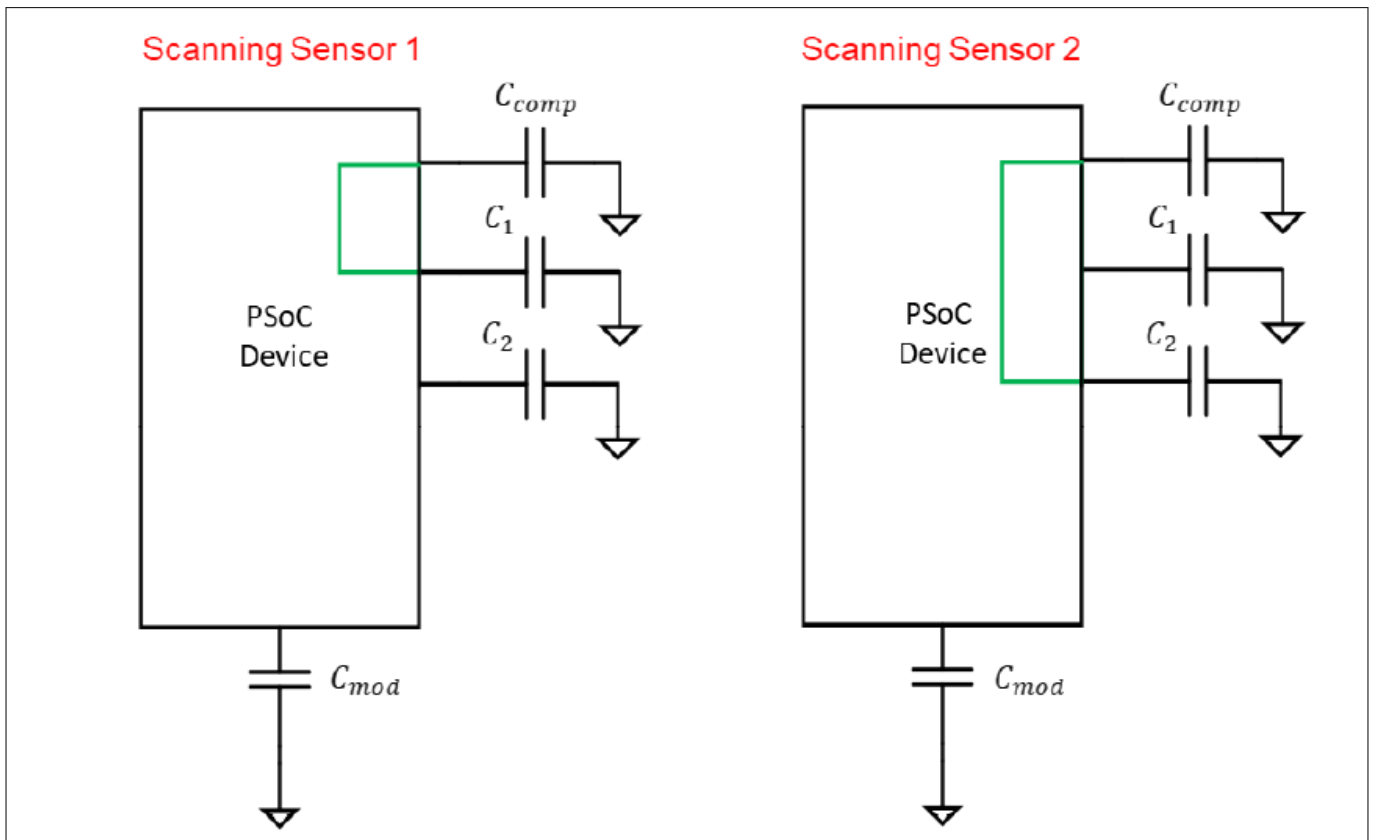

Figure 100 Gang the sensors to the external compensation capacitor

5.3.7.8 My slider centroid response is non-linear

Cause: Layout may not meet hardware design guidelines to ensure proper linearity.

Solution: Check the C_p of the sensors using the built-in self-test option in the General tab of the CAPSENSE™ configuration window and update the layout according to the [Slider design](#) section. See the [Component datasheet/middleware document](#) section for details on BIST API.

5.3.7.9 My slider segments have a large variation of CP

Cause: Your layout design caused your sensors to have an unbalanced C_p .

Solution: Your layout needs to be updated. Review [Slider design](#) and update your layout as required. If this is not immediately possible, you should re-tune every sensor to have a similar response. This will be a long iterative process and the preferred method is to update the hardware, if possible.

5.3.7.10 Raw counts show a level-shift or increased noise when GPIOs are toggled

Cause 1: The sensor traces are routed parallel to the toggling GPIOs on your PCB.

Solution: Your layout needs to be updated. Review [Trace routing](#) and update your layout as required. If the layout cannot be modified at the current stage, you could evaluate the use of firmware filters to reduce the peak-to-peak noise and hence improve SNR.

Cause 2: A large amount of current is being sunk through the GPIOs.

5 CAPSENSE™ performance tuning

Solution: Limit the amount of DC current sink through the GPIOs when CAPSENSE™ sensors are being scanned. See [Schematic rule checklist](#). If the current sink through GPIOs is firmware-controlled, and the raw count-level-shift caused by current sink has a large difference compared to the touch signal, you could implement firmware techniques like resetting or re-initializing the CAPSENSE™ baseline whenever the current sink is enabled through the GPIOs. The baseline of the CAPSENSE™ sensor could be reset by using the `CapSense_InitializeWidgetBaseline()` API function as shown below:

```
CapSense_InitializeWidgetBaseline(CapSense_CSD_BUTTON_WDGT_ID);
```

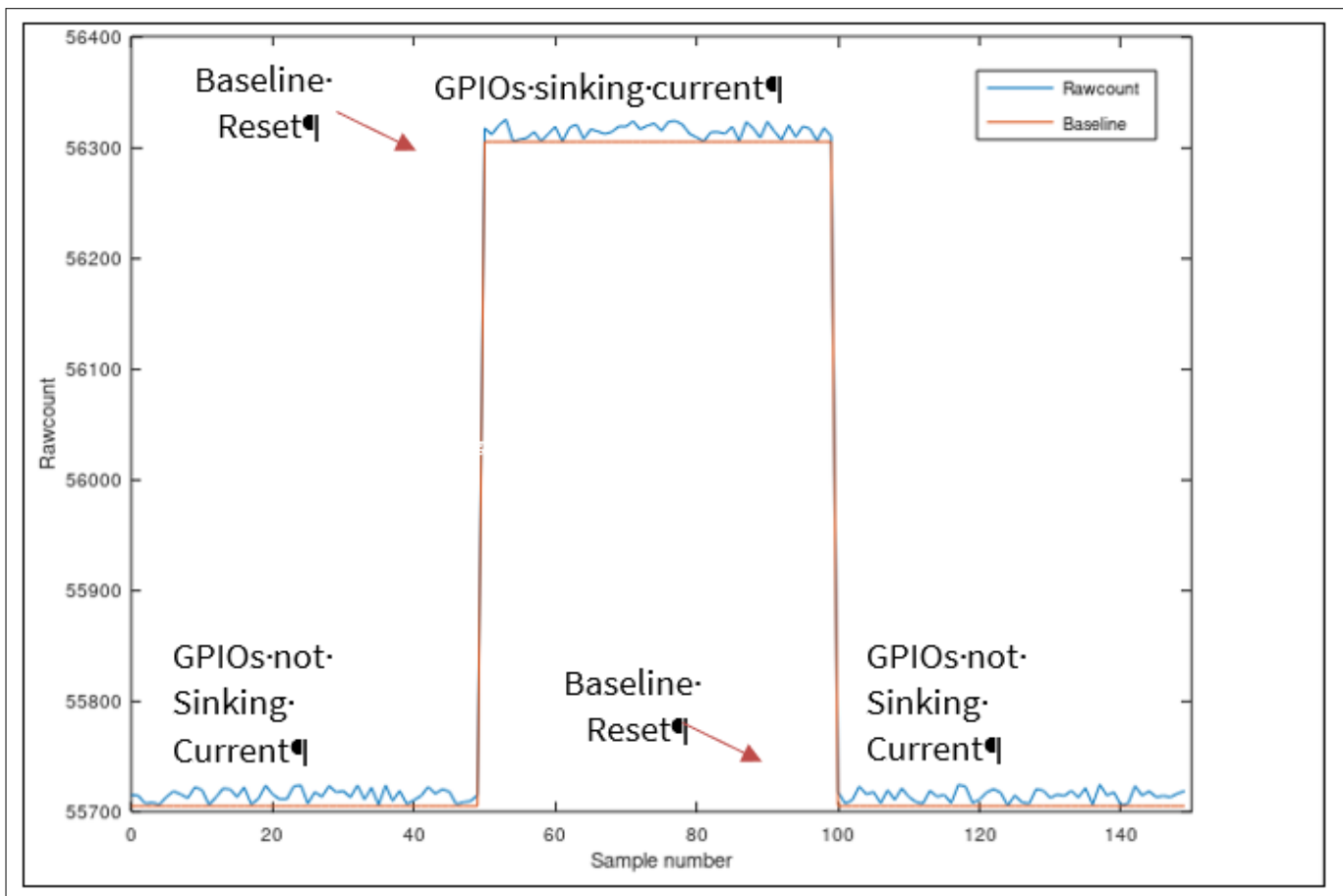

Figure 101 Resetting baseline using firmware technique

Cause 3: You did not follow the guidelines mentioned in [Sensor pin selection](#) section.

Solution: Follow the recommendations in [Sensor pin selection](#) section. In addition, for PSoC™ 6 family of devices, follow these guidelines on drive mode strength, switching frequency and slew rate selection, and so on:

- Reduce the drive strength of the switching GPIOs. [Table 22](#) lists the available drive strength options for the GPIOs. [Figure 102](#) shows an example on how to select the drive strength of the GPIOs using the [Device configurator](#) in the ModusToolbox™ project

Table 22 Drive strength for GPIOs

Drive strength	Drive current in mA
Full	8

(table continues...)

5 CAPSENSE™ performance tuning

Table 22 (continued) Drive strength for GPIOs

Drive strength	Drive current in mA
$\frac{1}{2}$	4
$\frac{1}{4}$	2
$\frac{1}{8}$	1

- Decrease the switching frequency of the GPIO being toggled
- Use GPIO slew rate as SLOW mode (note that this limits the toggling frequency to 1.5 MHz). See Table 40 for more details
- Use PRS as the Sense Clock source.
- If possible, reduce VDDA to lower than 2.7 V
- Try to restrict GPIO switching to intervals between CAPSENSE™ scans

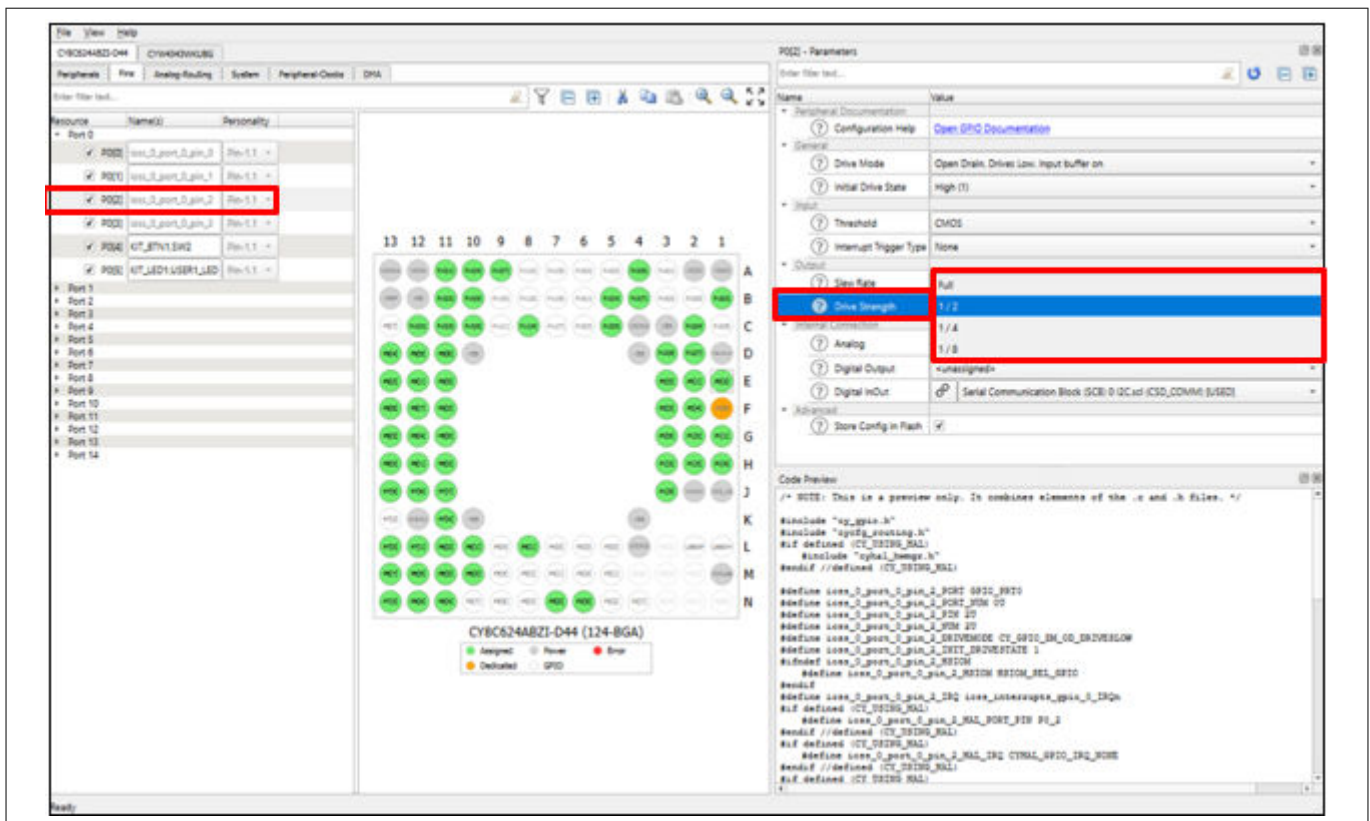

Figure 102 Selecting drive strength for GPIOs

5.3.7.11 I am getting a low SNR

Cause 1: Sensor is not tuned properly.

Solution: Follow the tuning guidelines in CAPSENSE™ performance tuning.

Cause 2: CAPSENSE™ and other peripherals are not properly assigned to the recommended pin.

Solution: See Sensor pin selection and Raw counts show a level-shift or increased noise when GPIOs are toggled for more details.

Cause 3: HFCLK source may be causing higher noise for a PSoC™ 6 device.

5 CAPSENSE™ performance tuning

Solution: For the best performance of CAPSENSE™ in PSoC™ 6 family of devices, use HFCLK derived from the IMO/ECO+PLL clock source. This clock source provides the best SNR performance. [Figure 103](#) shows how to change the clock settings using the System tab in the [Device configurator](#) for a ModusToolbox™ project. See [AN221774 - Getting started with PSoC™ 6 MCU](#) for more details on changing the device clock.

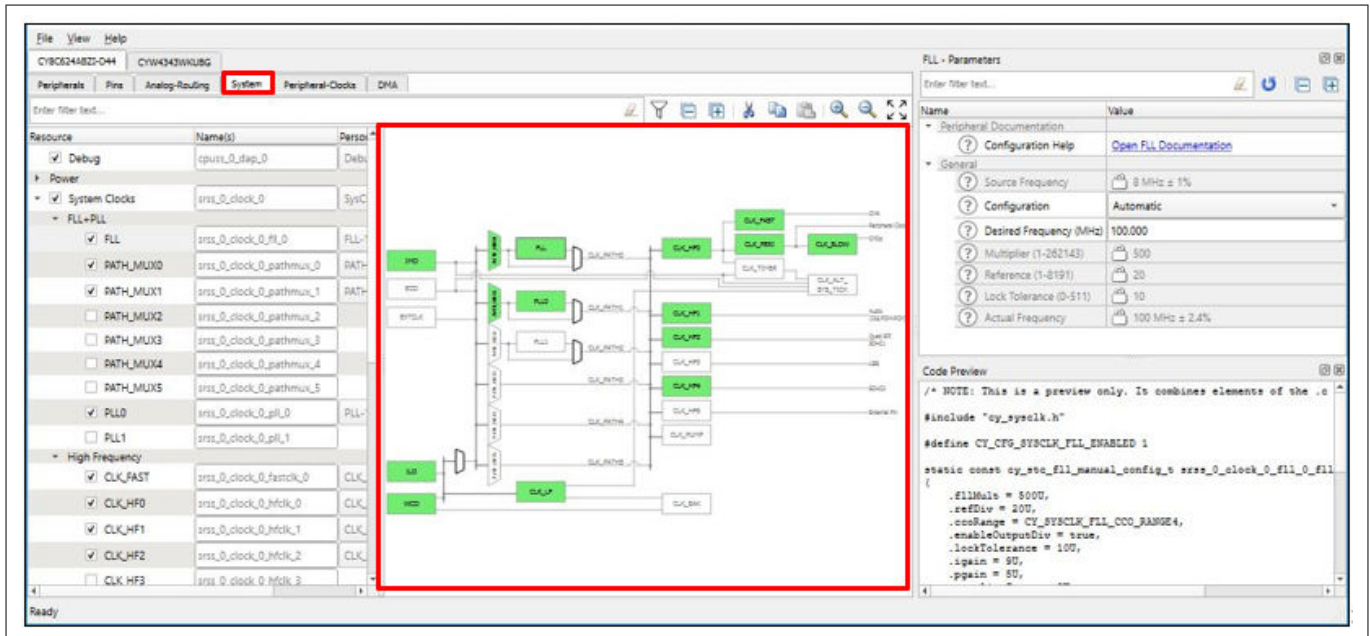

Figure 103 Changing clock settings in device configurator

5.3.7.12 I am observing a low CM for my CSX button

Cause: The mutual capacitance between the Tx and Rx electrode should be higher than approximately 750 fF for proper IDAC calibration.

Solution: It is recommended to have two free pins in your device with footprint to add extra Capacitance if C_M of the button turn out to be low. We could then increase the sensor C_M to the supported range by dynamically connecting external capacitor to the CSX sensor while scanning as shown in the below figure, where Pin1 is ganged to the Tx pin and Pin2 is ganged to the Rx pin of the sensor respectively. This will help in mitigating low C_M risk if it is found during testing phase. See [Component datasheet/middleware document](#) to understand how to gang the sensor.

[Figure 104](#) shows the addition of the external capacitor as a button widget in the CAPSENSE™ component and assigning dedicated pins to the Tx and Rx electrode. [Figure 105](#) shows the ganging of the sensor to the external capacitor by assigning Selected pins to both sensor pin and external capacitor pin, this must be done for both Rx and Tx electrode. There is no need to scan the external capacitor while scanning of the widgets, thus we can selectively scan widgets using the APIs `CapSense_SetupWidget()` and `CapSense_Scan()` provided by the CAPSENSE™ component.

5 CAPSENSE™ performance tuning

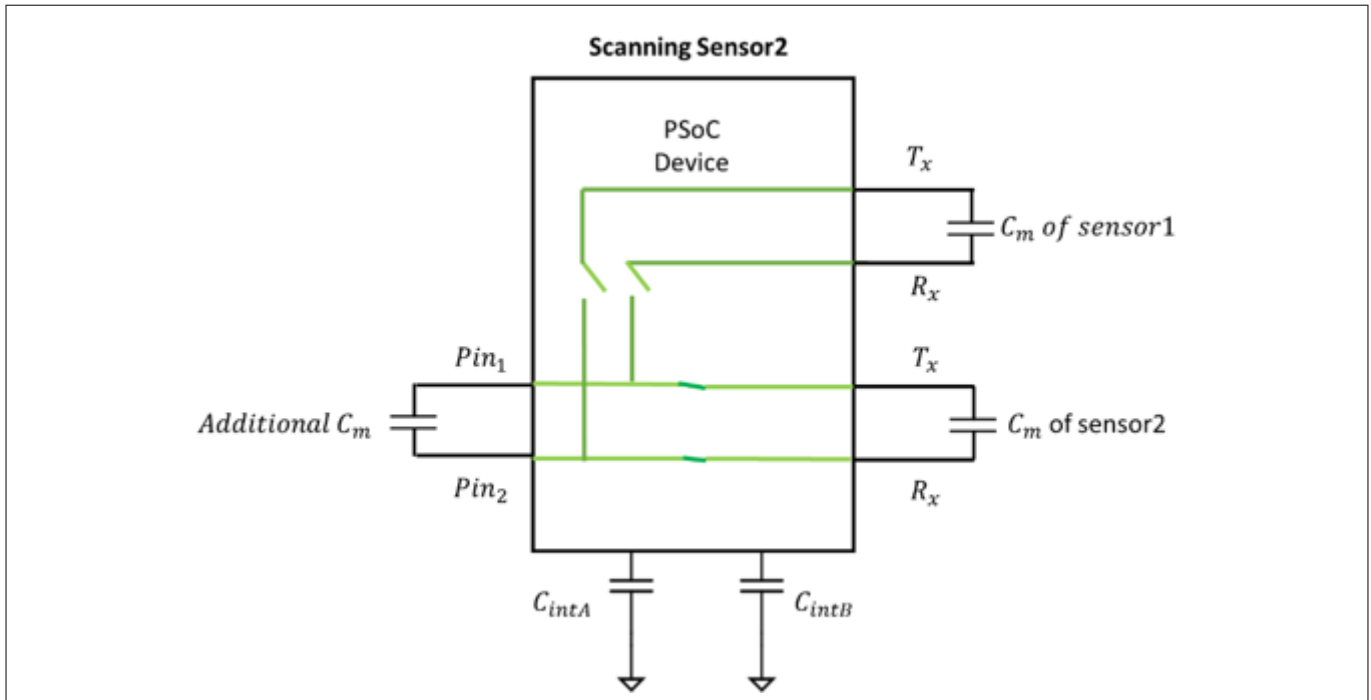

Figure 104 Ganging external capacitor to increase the C_M of the sensor

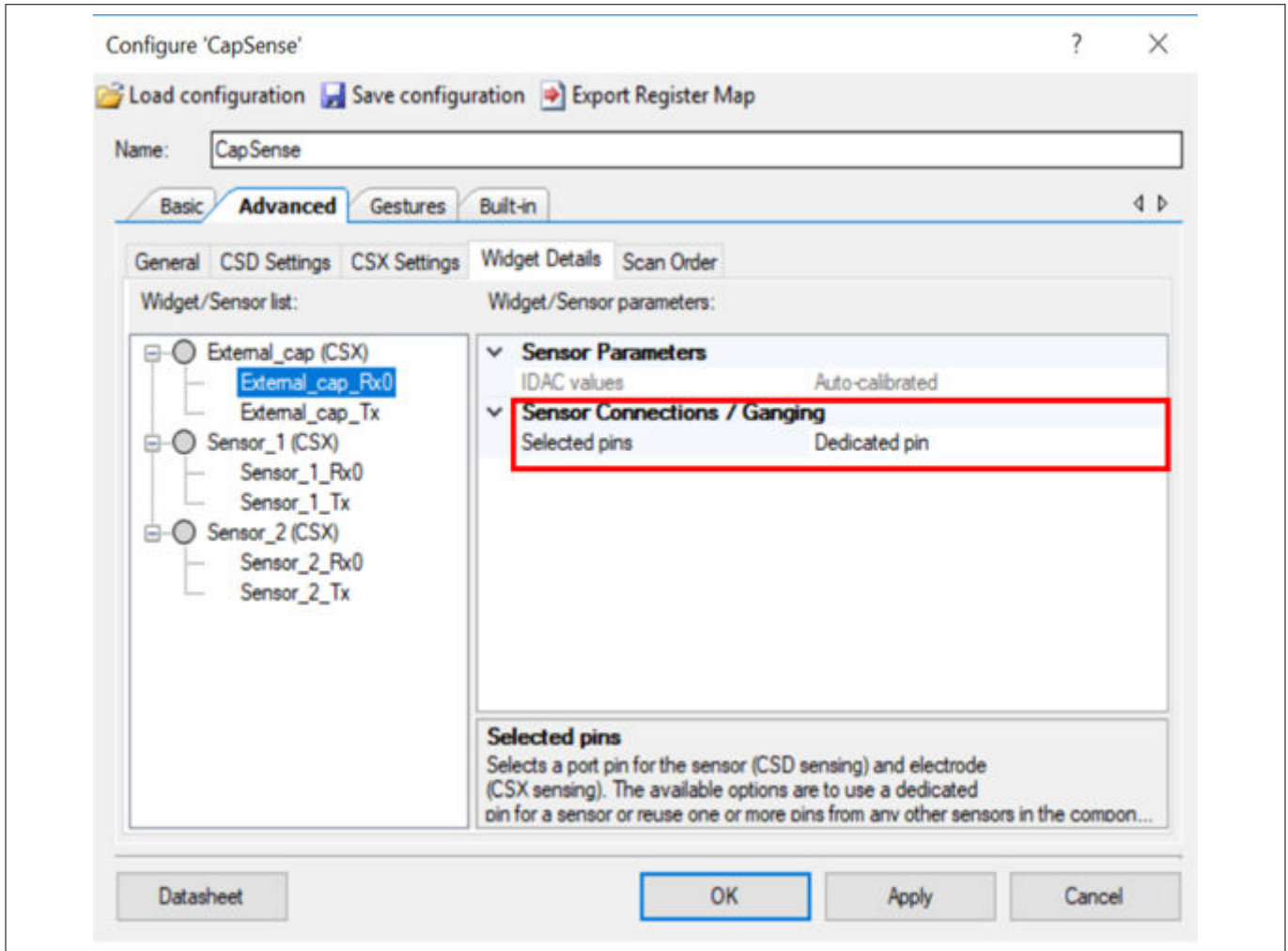

Figure 105 Assigning dedicated pins to the external capacitors

5 CAPSENSE™ performance tuning

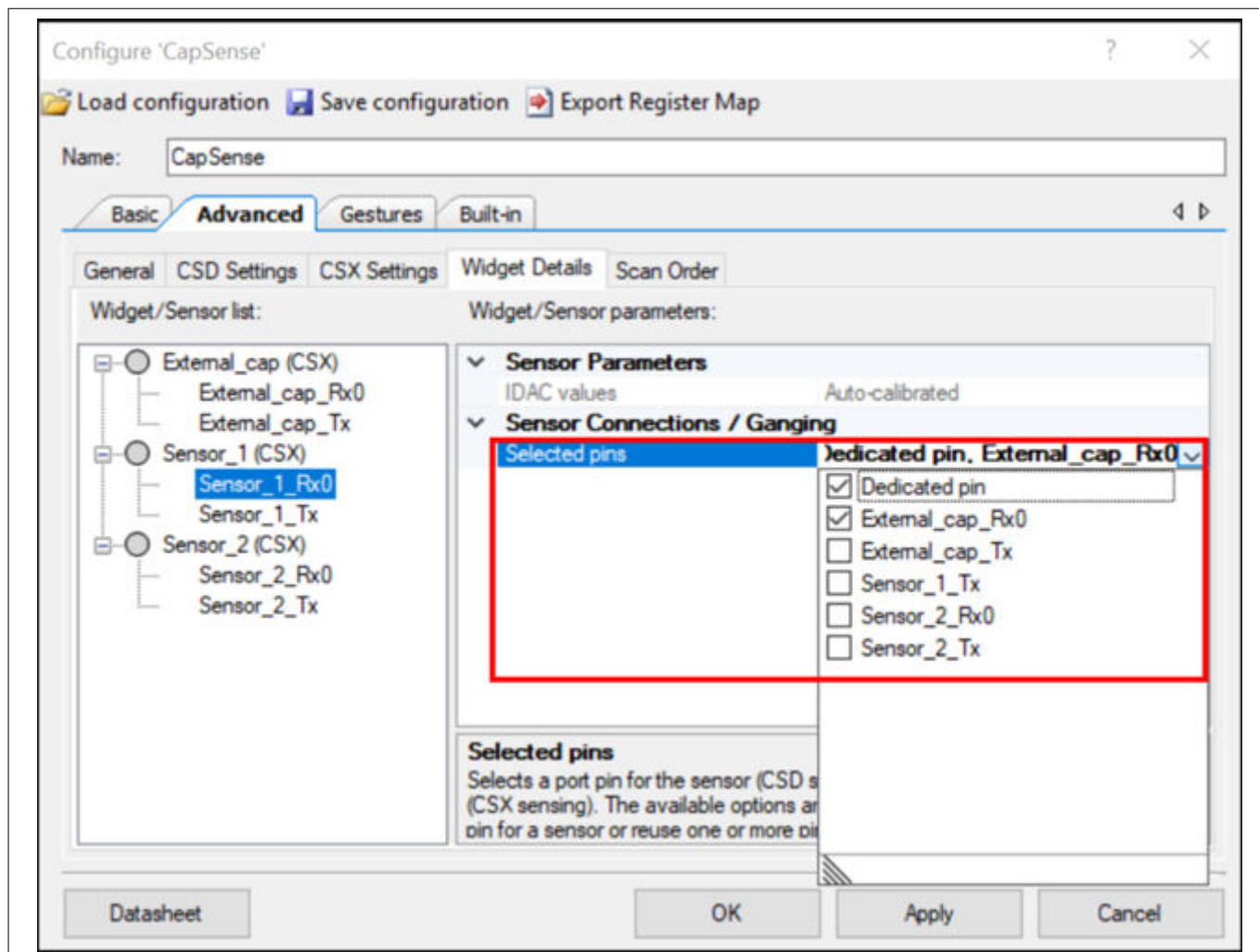

Figure 106 Gaining the external capacitor and sensor pin

6 Gesture in CAPSENSE™

6 Gesture in CAPSENSE™

6.1 Touch gesture support

The CAPSENSE™ Component in PSoC™ 4 and PSoC™ 6 MCU supports the gesture detection feature for sliders and touchpad widgets. It allows to identify different predefined gestures based on touch patterns on sliders and touchpad widget.

Note: The gesture detection feature is available for selected device part numbers. If you intend to use the gesture feature of the component, ensure that you select the device that supports this feature.

6.2 Gesture groups

Gestures are divided into several groups: Click, one-finger scroll, two-finger scroll, two-finger zoom, one-finger edge swipe, one-finger flick, and one-finger rotate.

Table 23 lists the gestures supported by various widgets. See [Component datasheet/middleware document](#) for more details on how these gestures are defined and the parameter that to be configured in the CAPSENSE™ configurator to detect these gestures.

Table 23 Gesture supported by different CAPSENSE™ widgets

Widget type	Gesture groups						
	Click	One-finger scroll	Two-finger scroll	One-finger flick	One-finger edge swipe	Two-finger zoom	One-finger rotate
Button	✓	–	–	–	–	–	–
Linear slider	–	✓	–	✓	–	–	–
Radial slider	✓	–	–	–	–	–	–
Matrix buttons	–	–	–	–	–	–	–
Touchpad	✓	–	–	✓	–	–	✓
Proximity	–	–	–	–	–	–	–

6.3 One-finger gesture implementation

Implementing gesture detection involves following steps:

1. [Tuning the widget](#)
2. [Selecting predefined gesture](#)
3. [Firmware implementation with timestamp](#)
4. [Tuning gesture parameters](#)

6.3.1 Tuning the widget

Tune the CAPSENSE™ hardware and software parameters for the widget. Generally, in a gesture application, because of the speed and orientation of the finger movement changes, the finger may make a very little contact with the widget. This could be confirmed by viewing the centroid data in the [Tuner GUI](#) when the gesture is being performed. If the sensitivity is good enough, you will get the data without any break. If you observe any break in the centroid data, increase the sensitivity until the data for the gesture is complete and appear without any break.

6 Gesture in CAPSENSE™

Ensure that you get a SNR above 5:1 for the slight finger contact that you may want to detect. Also, ensure that you have a linear centroid response with respect to the finger position on the slider or touchpad. Tune the sensors using guidelines in section [Slider widget tuning](#) tuning or [Touchpad widget tuning](#) for achieving the same

6.3.2 Selecting predefined gesture

First, enable Gestures in the Gesture tab in CAPSENSE™ Component. All gesture-related configuration parameters appear after enabling gestures; these parameters are systematically arranged by widgets/gesture groups as [Table 23](#) shows. According to the application requirement, you can enable and disable gestures by selecting the specific checkbox. Do the following to enable gestures and configure the corresponding parameters.

- Select the widget for which gesture feature must be enabled in the Widget pane. If you have multiple widgets in the project, the PSoC™ Creator allows gesture recognition only one widget. However, in ModusToolbox™, gesture recognition can be enabled on more than one widget
- Select the desired gestures in **Gestures** pane. User has an option to select multiple gestures. In PSoC™ Creator, you cannot enable scroll gesture and flick gesture at the same time. This is applicable for both sliders and touchpad. However, in ModusToolbox™, you can enable more than one gesture according to the application requirement
- Configure all parameters in the Parameter pane. When a gesture is selected, the right pane of the window displays the parameters of the selected gesture group. See the [Component datasheet/middleware document](#)

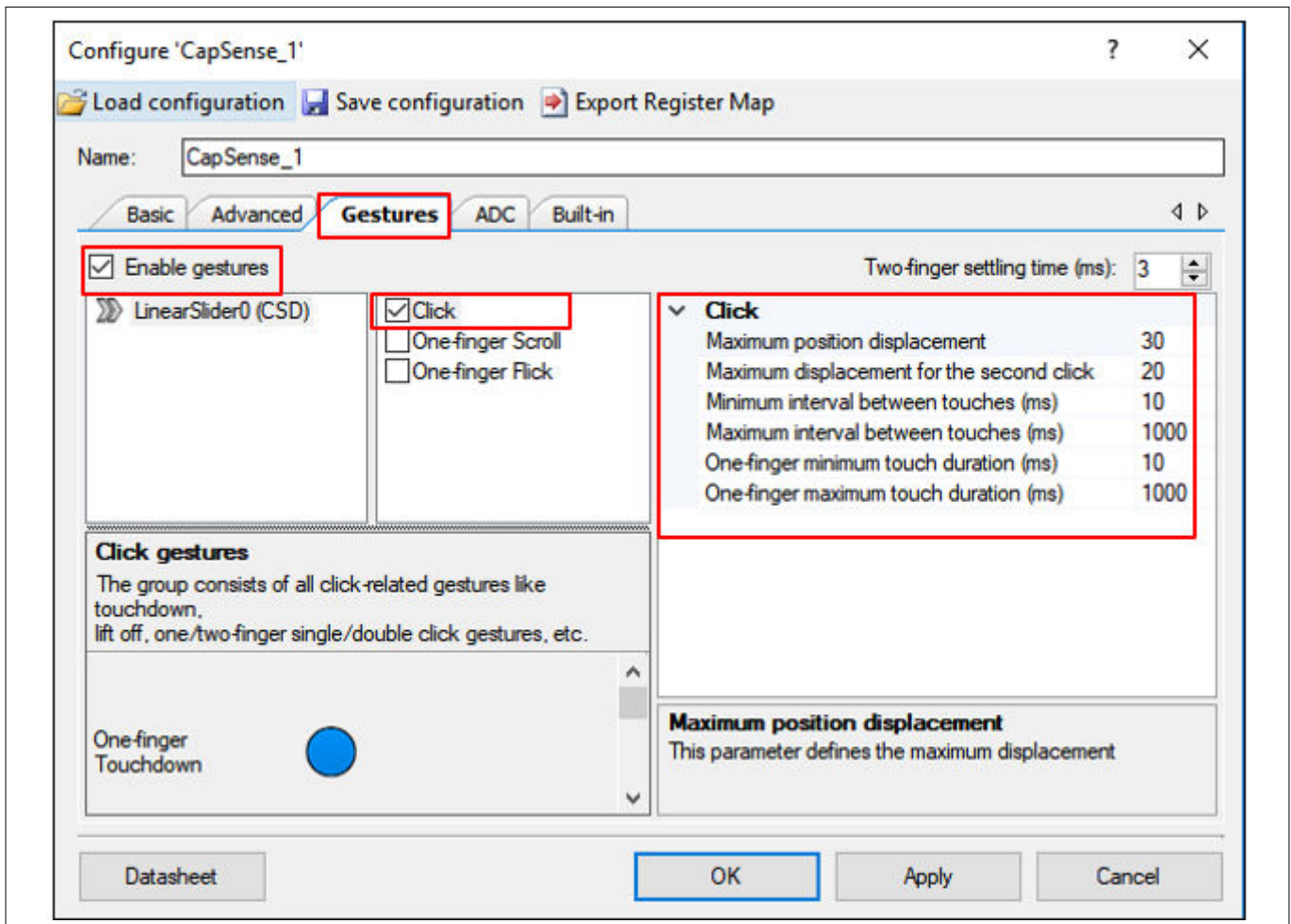

Figure 107 Configuring gestures in CAPSENSE™ component

6 Gesture in CAPSENSE™

6.3.3 Firmware implementation with timestamp

See the code example [PSoC™ 4 CAPSENSE™ Touchpad Gestures](#) to understand how to implement timestamp for gesture recognition. Because each gesture has a pattern of touch that changes with time, a reference timestamp is needed for properly getting the touch data with respect to time. This time stamp represents the sampling rate for the gesture recognition algorithm. Both the centroid positions and their respective timestamp are used by the gesture decoding API to determine different predefined gesture patterns that are applicable for the widget.

First, tune the widget using the procedure described in [Tuning the widget](#) and determine the time interval between two successive CAPSENSE™ scans in the firmware. Update the timestamp exactly with this duration. The way to accurately determine it is to toggle a GPIO in the firmware after the CAPSENSE™ scan is complete and find the time duration using an oscilloscope.

6.3.4 Tuning gesture parameters

This section describes how to set gesture parameters for sliders; the same procedure could be extended to the gesture groups supported by touchpads. CAPSENSE™ sliders support Click, One-finger Scroll, and One-finger flick gesture features. See the [Component datasheet/middleware document](#).

6.3.4.1 Using tuner GUI for tuning gesture parameters

You can use the **Gesture View** in [Tuner GUI](#) for tuning the gesture parameters and visualize and analyze the performance of the gesture detected in the end system.

Ensure the following while using [Tuner GUI](#) for gestures:

1. For tuning gesture parameters in runtime, [Tuner GUI](#) must be used with EZI2C. Use Synchronized communication mode for visualizing the detected gestures in runtime. For more details on using the [Tuner GUI](#), see the [Component datasheet/middleware document](#) and the [PSoC™ 4 CAPSENSE™ touchpad gestures code example](#). All the parameters for the gestures that are available in the CAPSENSE™ configurator are available in [Tuner GUI](#), where you can directly edit these values for tuning.
2. As [Figure 108](#) shows, the Gesture View tab is organized into different panes as follows:
 - Gesture Event History** pane shows detected gestures and their positions on the widget.
 - Detected Gesture** pane indicates the detected gesture. If the delay checkbox is enabled, a gesture picture is displayed for the specified time-interval; if delay is disabled, the last reported gesture picture is displayed until a new gesture is reported.
 - Cypress® Icon** in the Tuner GUI moves according to the scroll gesture. It indicates how well the parameter of the scroll gesture is tuned. This dynamic feature gives performance feedback for further fine-tuning gesture parameters.

6 Gesture in CAPSENSE™

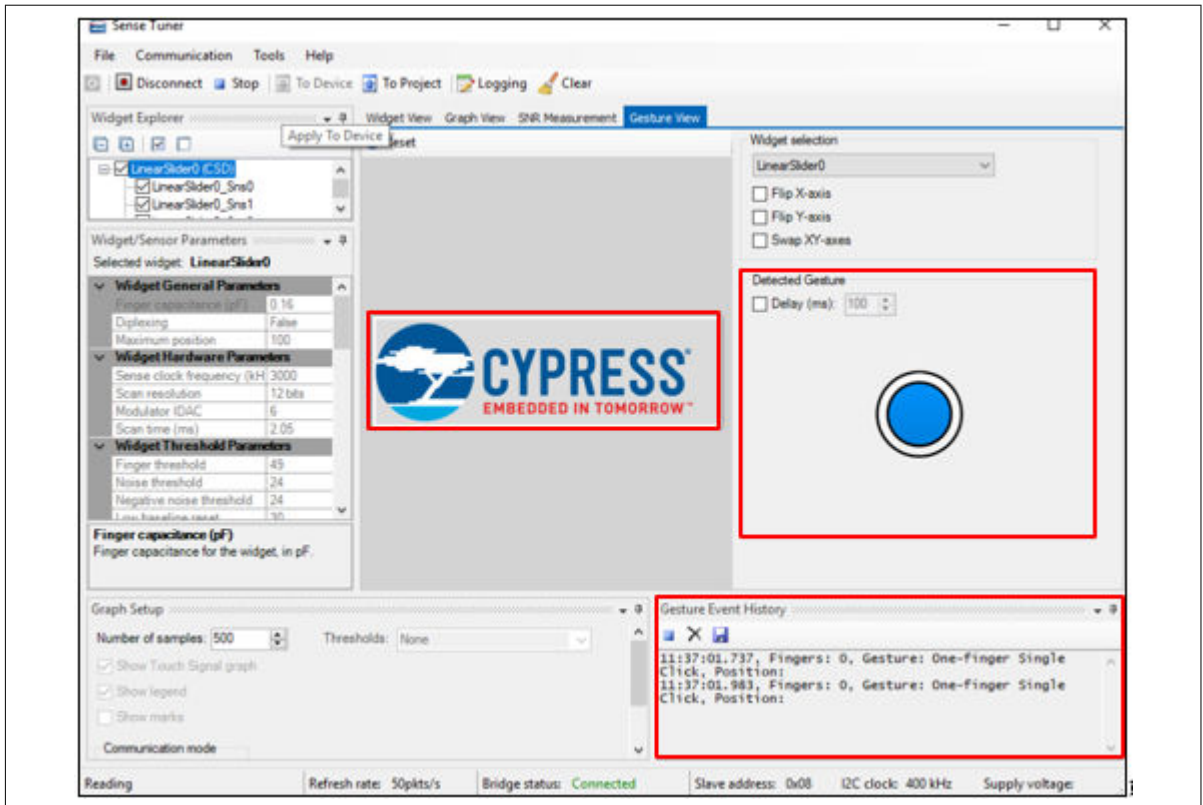

Figure 108 Tuner GUI for gestures

- Determining the event duration using Tuner GUI. A general equation to determine the event duration is given by Equation 75.

$$\text{Event duration} = \text{No. of samples} \times T_{\text{sample}}$$

Equation 75 Gesture duration

Where,

No. of Samples = Number of samples the gesture event occurred. This data could be obtained from the Graph View in the Tuner GUI.

T_{sample} = Time interval between two samples.

$$T_{\text{sample}} = \frac{1}{\text{Refresh rate}}$$

6 Gesture in CAPSENSE™

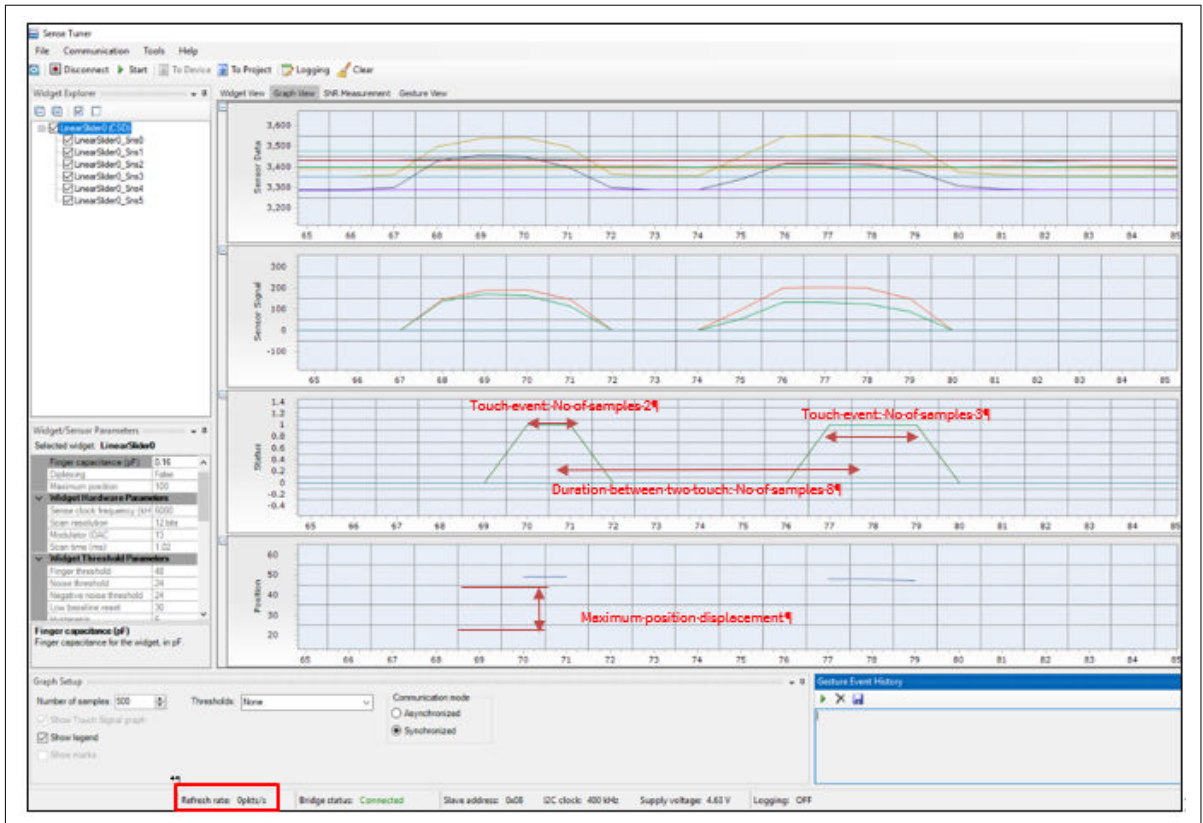

Figure 109 Determining the Gesture parameters using Tuner GUI

6.3.4.2 Click

There are two type of click gestures: single-click and double-click. Table 24 lists the parameters to be configured for the Click gesture in both PSoC™ Creator and in ModusToolbox™. See Component datasheet/ middleware document. Table 25 provides the recommended values of the gesture parameter for the Click gesture.

Table 24 Click gesture parameters

Gesture	PSoC™ Creator	ModusToolbox™
Single-click	One finger minimum touch duration	Minimum click timeout
	One finger maximum touch duration	Maximum click timeout
	Maximum position displacement	Maximum click distance
Double-click	Minimum interval between touches	Minimum second click interval
	Maximum interval between touches	Maximum second click interval
	Maximum displacement for the second click	Maximum second click distance

Table 25 Recommended values for click gestures

Parameters	Typical values
Maximum position displacement	20% of maximum position of the slider
Maximum position displacement for the second click	20% of maximum position of the slider

(table continues...)

6 Gesture in CAPSENSE™

Table 25 (continued) Recommended values for click gestures

Parameters	Typical values
Minimum interval between touches (ms)	60
Maximum interval between touches (ms)	400
One finger minimum touch duration (ms)	20
One finger maximum touch duration (ms)	400

6.3.4.2.1 Single click

A single click is defined as a touch-down event followed by a lift-off. [Figure 110](#) shows the spatial and timing condition that must be satisfied for a valid single-click event.

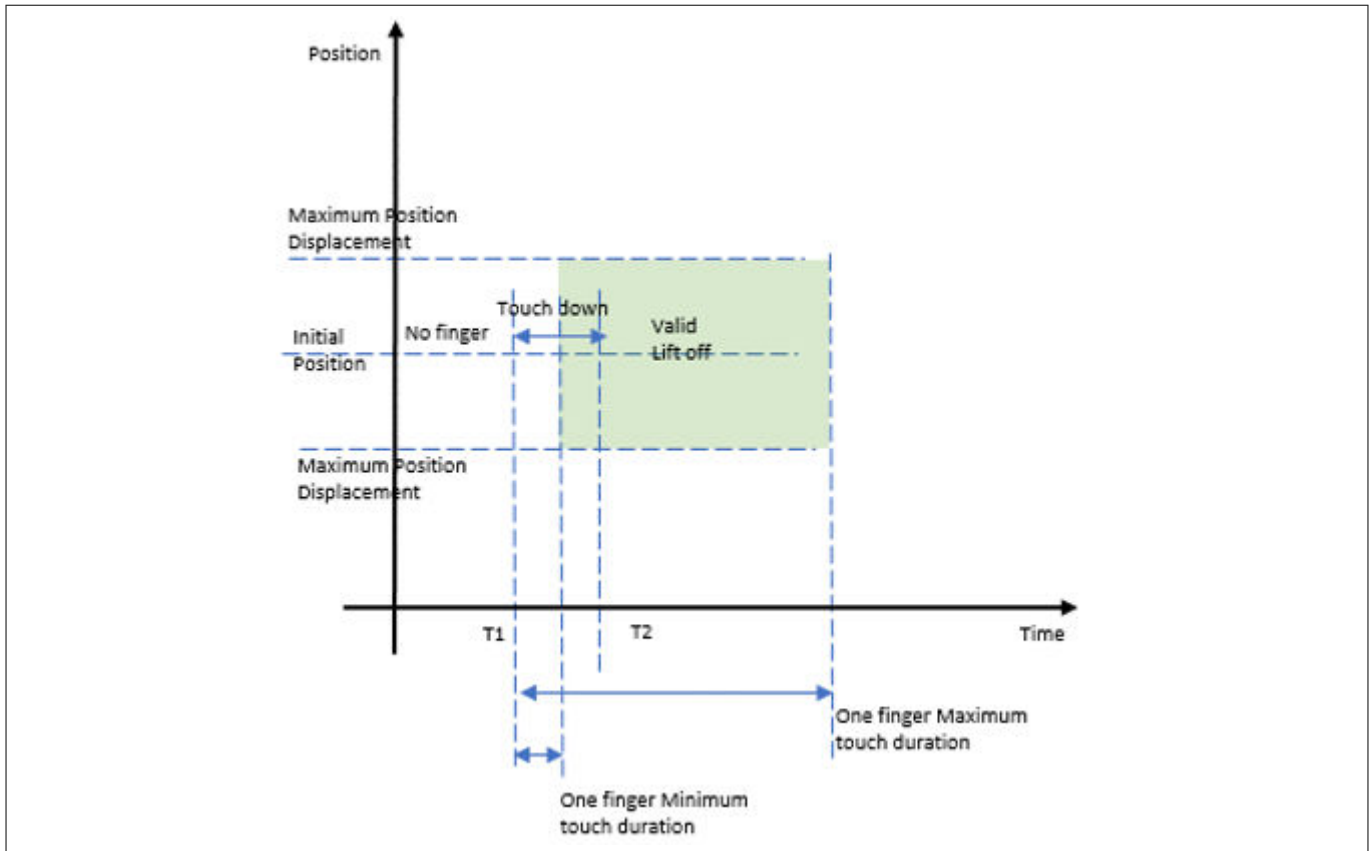

Figure 110 Single-click gesture

From [Figure 110](#), at time T1, the finger touched down on the slider; at time T2, the finger is lifted off from the slider. For a valid single click, the touch-down duration should be between the “One finger minimum touch duration” and “one-finger maximum touch duration” and the relative position of the liftoff from the initial position of touch should be less than the “Maximum position displacement” parameter.

The duration of each single-click event can be determined by using [Equation 75](#) by finding the number of samples for the single click in the **Graph** view of [Tuner GUI](#) and the refresh rate as shown in [Figure 109](#). From the single-click event duration, fix the parameters “One-finger minimum touch duration” and “One-finger maximum touch duration”. The maximum position displacement parameter can be determined by observing the maximum variation in the centroid position using the [Tuner GUI](#) as shown in [Figure 109](#). The recommended value is 20 percent of the maximum centroid position of the slider as mentioned in [Table 24](#).

6 Gesture in CAPSENSE™

6.3.4.2.2 Double click

A double click is two single-clicks event occurring one after another with the second click occurring between the minimum and maximum time interval between the two touches. In addition, the relative position of the second click from the initial position of touchdown event should be less than the maximum position displacement for the second click. Figure 111 shows the spatial and timing conditions that must be satisfied for a valid double-click event.

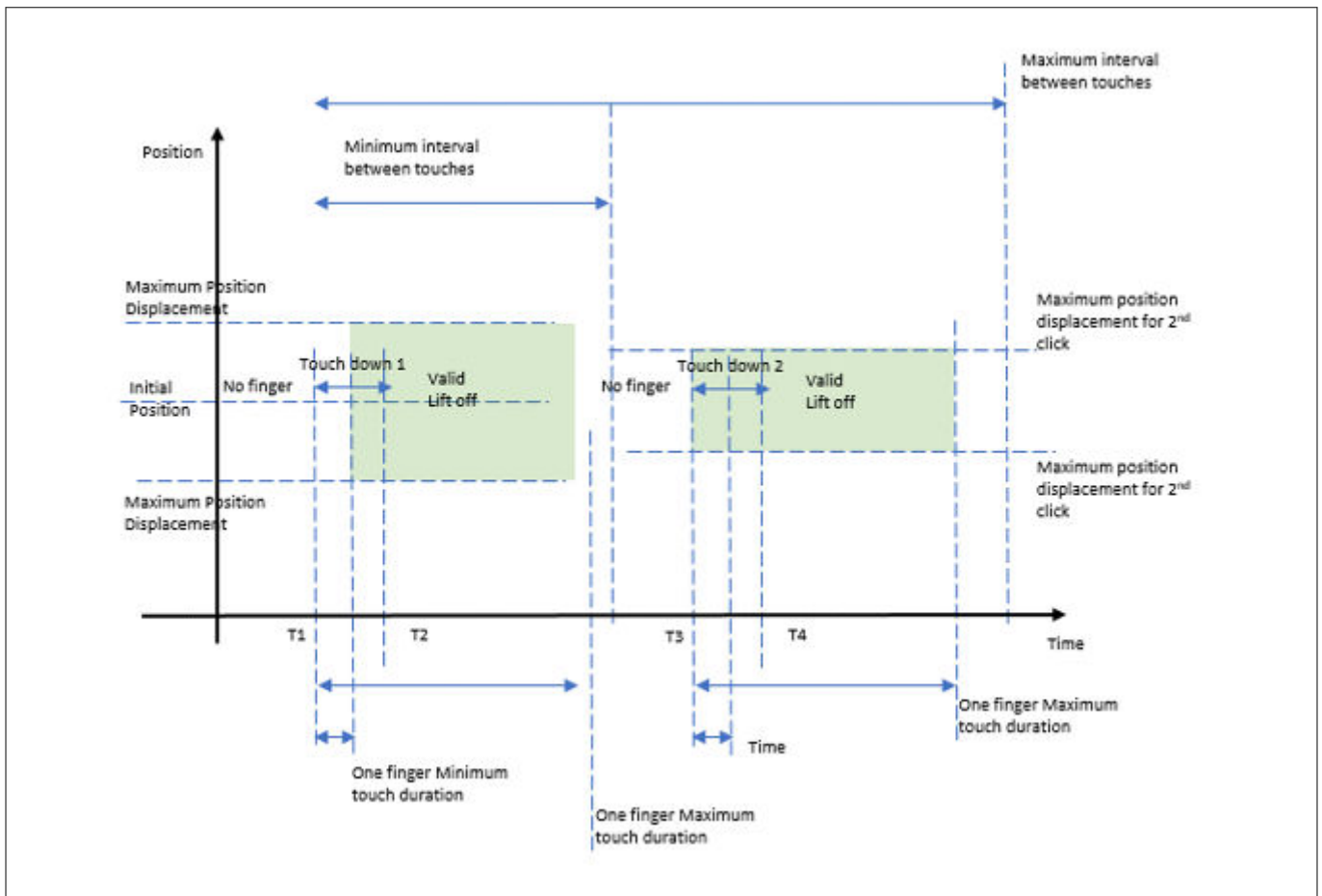

Figure 111 Double-click gesture

From Figure 111, at time T1, the finger touched down on the slider for the first click; at time T2, the finger is lifted off from the slider. At T3, the finger touched down on the slider for the second click; at T4, the finger is lifted off from the slider. For a valid double click, each click should satisfy the condition of single click, and the second click should occur between Minimum and Maximum interval between touch parameters.

Using the Graph view in the Tuner GUI, observe the double-click touch data. Determine the parameter of single click as mentioned in the Single click section. Determine the duration between the two touches using the Graph view in the Tuner GUI and set the value of the minimum and maximum intervals between touch parameters. A typical captured data for the double-click event is shown in Figure 109.

6.3.4.3 Scroll

There are two different scroll gestures that can be detected on sliders: One-finger scroll and One-finger Inertial scroll. See Component datasheet/middleware document. Table 26 shows the parameters to be configured for the scroll gesture.

Note: One-finger Inertial Scroll gesture is not supported in ModusToolbox™.

6 Gesture in CAPSENSE™

Table 26 One finger scroll parameters

Gesture	PSoC™ Creator	ModusToolbox™
One-finger scroll	Position threshold N	Minimum scroll distance
	Scroll step	-
	Debounce	Scroll debounce
One-finger inertial scroll	Position inertial threshold	NA
	Count level	

6.3.4.3.1 One-finger scroll

A One-finger Scroll gesture is a combination of a touchdown followed by a displacement in specific direction. The change in position between two consecutive scans must exceed the Position Threshold value given in the configurator after tuning. See [Component datasheet/middleware document](#).

Follow these steps to set the scroll gesture parameter values as shown in [Table 26](#).

1. Determine the number of samples of the scroll gesture from the **Graph** view (Centroid position) in [Tuner GUI](#)
2. By using [Equation 75](#) determine the duration of the complete scroll
3. Determine the change in centroid position for the complete scroll using the [Tuner GUI](#)
4. Determine Position Threshold [Equation 76](#). Each gesture is scanned at a sample rate that is set in the timestamp in the application code. The position threshold is given by the change in the centroid position for the duration that is set in the timestamp

$$\text{Position Threshold} = \frac{\text{Change in Centroid position}}{\text{Total duration of scroll}} \times \text{Duration of timestamp}$$

Equation 76 Equation to determine position threshold

5. In PSoC™ Creator, set four different position thresholds and their scroll count values in the configurator, which are determined by varying the speed of the scroll gesture. Now, change the speed of scroll and repeat the steps 1 – 4 and set these position threshold values. In ModusToolbox™ has only one parameter: Minimum Scroll distance; determine its value in the same way you determined the position threshold
6. Read the scroll step from the CAPSENSE™ data structure and use it to control the speed and smoothness of the scroll gesture. The scroll step depends on the position threshold. This scroll step is used in the application code to control the actual variable value to be changed with respect to scroll.

Note: The scroll step parameter is not available in ModusToolbox™.

7. Set the maximum slider position as ten times the dimension of the slider as a general rule. If you set scrollDistanceMin=10, everything below a 1-mm movement will not detect the scroll gesture. Everything above this number might detect a gesture

Observe the **Cypress®** icon in the Tuner GUI (see [Figure 108](#)) to get a feedback on how well the tuning has been done for the scroll gesture in the given hardware. You can also print the variable that must be controlled by scroll through UART to visualize how the value is changing with respect to scroll. This could be used as a visual feedback. The position threshold parameters and the corresponding step counts should be tuned until the variation in the variable value with respect to scroll meet the requirement of the end user application.

6 Gesture in CAPSENSE™

6.3.4.3.2 One-finger inertial scroll

The one-finger Inertial scroll gesture is defined as a touchdown event followed by a minimum displacement in a specific direction, and then a liftoff. The movement of scroll will automatically stop when it reaches the end value of the variable. See [Component datasheet/middleware document](#).

The gesture parameter is provided in [Table 26](#). The position inertial threshold parameter is given by the minimum change in centroid position that is required before a liftoff; its value can also be determined by steps in the [One-finger scroll](#) section. The count value parameter defines the momentum of scroll; it can take two possible values: low or high. Choose the count value according to the end application requirement.

6.3.4.4 One-finger flick

A flick gesture is a touchdown event followed by a high-speed displacement and a liftoff event (see [Component datasheet/middleware document](#)). The flick gesture is similar to the One-finger Inertial Scroll; the only difference is that it requires a high-speed displacement followed by a liftoff event within the maximum sample interval defined in the configurator. You can determine the position threshold and the maximum sample interval by following the same procedure in [One-finger scroll](#) section and by using [Equation 75](#).

Table 27 One-finger flick gesture parameters

Gesture	PSoC™ Creator	ModusToolbox™
One Finger Flick Gesture	Position threshold	Minimum flick distance
	Maximum sample interval	Maximum flick timeout

6.3.5 Two-finger gesture implementation

Two-finger gestures such as Two-finger Scroll and Two-finger Zoom are supported in the touchpad widget. You must enable this feature in the **Widget Details** tab of the Touchpad Widget. The procedure for tuning the parameters is the same as mentioned in the [One-finger gesture implementation](#) section (see [Component datasheet/middleware document](#)). [Figure 112](#) shows how to enable two-finger touch gestures in the configurator, select the centroid type as **5 x 5 Centroid**, and set the two-finger detection as **True**.

6 Gesture in CAPSENSE™

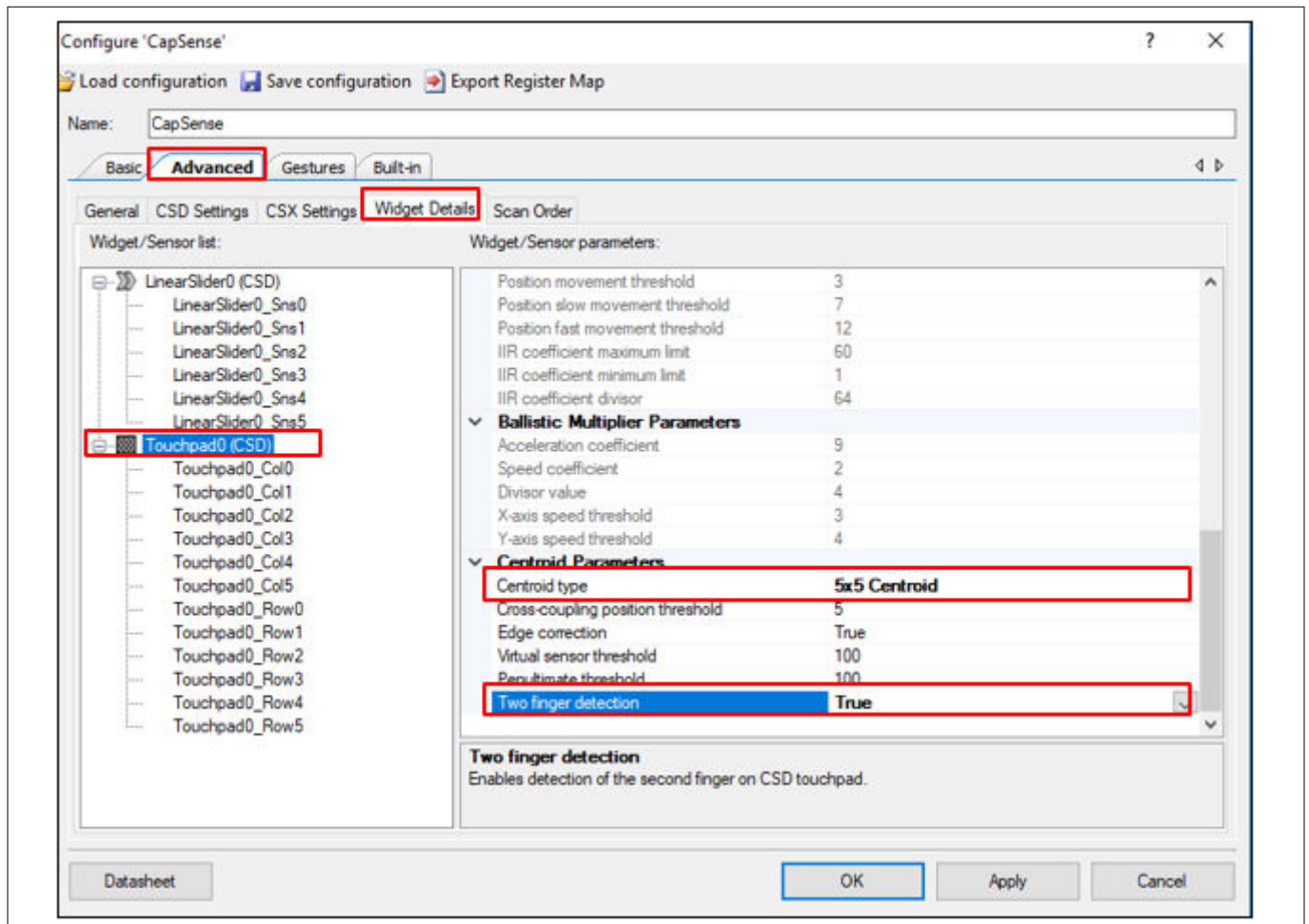

Figure 112 Enabling two-finger touch gestures in the CAPSENSE™ component

6.3.6 Advanced filters for gestures

Advanced filtering features for gestures such as Ballistic multiplier, Adaptive IIR filter, and the Edge correction feature are available to improve gesture recognition and the user experience.

See [Component datasheet/middleware document](#).

7 Design considerations

7 Design considerations

This chapter explains the firmware and hardware design considerations for CAPSENSE™.

7.1 Firmware

The [CAPSENSE™ component](#) provides multiple application programming interfaces to simplify firmware development. The CAPSENSE™ [Component datasheet](#) provides a detailed list and explanation of the available APIs. You can use the CAPSENSE™ [Example projects](#) provided in PSoC™ Creator or ModusToolbox™ to learn schematic entry and firmware development. See [Chapter 4](#) for more details.

The CAPSENSE™ scan is non-blocking in nature. The CPU intervention is not required between the start and the end of a CAPSENSE™ scan. Therefore, you can use CPU to perform other tasks while a CAPSENSE™ scan is in progress. However, note that CAPSENSE™ is a high-sensitive analog system. Therefore, sudden changes in the device current may increase the noise present in the raw counts. If you are using widgets that require high

7 Design considerations

sensitivity such as proximity sensors, or buttons with thick overlay, you should use a blocking scan. Example firmware for a non-blocking scan is shown below.

```
/* Enable global interrupts */
CyGlobalIntEnable;

/* Start EZI2C component */
EZI2C_Start();

/*
 * Set up communication data buffer to CapSense data structure to be
 * exposed to I2C master at primary slave address request.
 */
EZI2C_EzI2CSetBuffer1(sizeof(CapSense_dsRam),
sizeof(CapSense_dsRam),
(uint8 *)&CapSense_dsRam);

/* Initialize CapSense component */
CapSense_Start();
/* Scan all widgets */
CapSense_ScanAllWidgets();

for(;;)
{
    /* Do this only when a scan is done */
    if(CapSense_NOT_BUSY == CapSense_IsBusy())
    { /* Process all widgets */
        CapSense_ProcessAllWidgets();
        /* Scan result verification */
        if (CapSense_IsAnyWidgetActive())
        {
            /* Add any required functionality
            based on scanning result */
        }
        /* Include Tuner */
        CapSense_RunTuner();
        /* Start next scan */
        CapSense_ScanAllWidgets();
    }
    /* CPU Sleep */
    CySysPmSleep();
}
}
```

You should avoid interrupted code, power mode transitions, and switching ON/OFF peripherals while a high-sensitivity CAPSENSE™ scan is in progress. However, if you are not using high-sensitivity widgets, you can use CPU to perform other tasks. You can also use low-power mode of PSoC™ to reduce the average power consumption of the CAPSENSE™ system, as explained in the next section. Monitoring and verifying the raw counts and SNR using the Tuner GUI is recommended if you are using a non-blocking code.

If you want to develop firmware using the ModusToolbox™ software, see the references in the [ModusToolbox™](#) section of this document.

7 Design considerations

7.1.1 Low-power design

PSoC™ low-power modes allow you to reduce overall power consumption while retaining essential functionality. See [AN86233 - PSoC™ 4 low-power modes and power reduction techniques](#), for a basic knowledge of PSoC™ 4 low-power modes, see [AN219528 - PSoC™ 6 MCU low-power modes and power reduction techniques](#), for PSoC™ 6's low-power modes and [AN210998 - PSoC™ 4 low-power CAPSENSE™ design](#), for design a low-power CAPSENSE™ application.

The CPU intervention is not required between the start and the end of a CAPSENSE™ scan. If the firmware does not have any additional task other than waiting for the scan to finish, you can put the device to Sleep mode after initiating a scan to save power. When the CSD hardware completes the scan, it generates an interrupt to return the device to the Active mode.

There are different firmware and hardware techniques to reduce the power consumption of the CAPSENSE™ system.

1. If you use APIs that scan multiple widgets together, the device returns to Active mode after finishing the scan of a single widget. Therefore, you should scan each widget individually for reducing the power consumption in the design. See the CAPSENSE™ Component datasheet
2. You can use the Deep-Sleep mode of PSoC™ to considerably reduce the power consumption of a CAPSENSE™ design. However, the CAPSENSE™ hardware is disabled in the Deep-Sleep mode. Therefore, the device must wake up frequently to scan for touches. You can use the watchdog timer (WDT) in PSoC™ to wake up the device from the Deep-Sleep mode at frequent intervals. Increasing the frequency of the scans improves the response of the CAPSENSE™ system, but it also increases the average power consumption
3. As the number of sensors in the design increases, the device has to spend more time in the Active mode to scan all sensors. This, in turn, increases the average power consumption. For saving power in a design with multiple sensors, you should include a separate [proximity loop](#) that surrounds all the sensor. When the device wakes up from the Deep-Sleep mode, only scan this proximity sensor. If the proximity sensor is active, the device must stay in the Active mode and scan other sensors. If the proximity sensor is inactive, the device can return to the Deep-Sleep mode. [Figure 113](#) illustrates this process

7 Design considerations

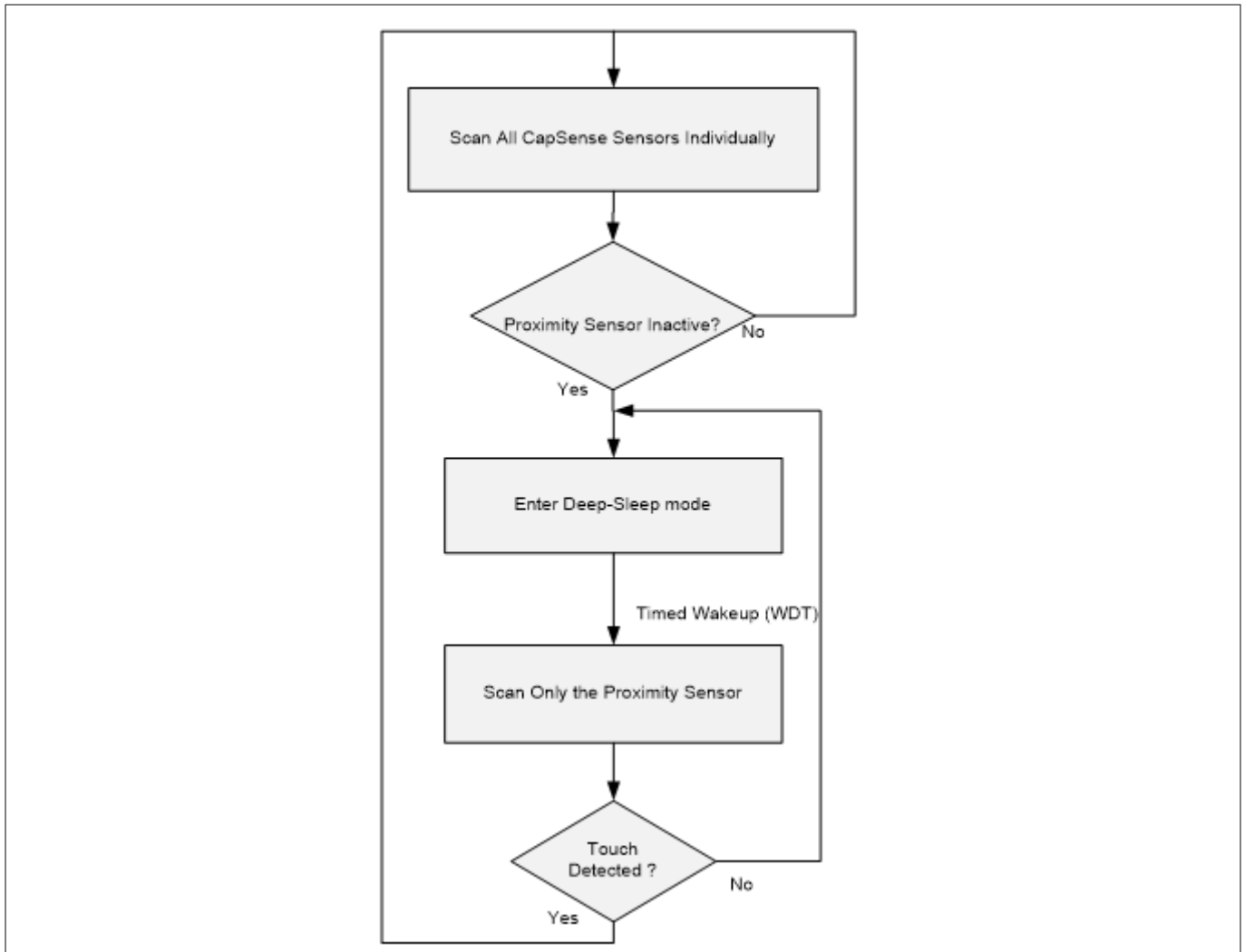

Figure 113 Low-power CAPSENSE™ Design

1. The CAPSENSE™ component can reduce power consumption by reducing the execution time of scanning by ganging sensors together and managing scanning at the application level. In this case, all the sensors in the design are “ganged” that is, simultaneously connected to the AMUX bus to form a virtual sensor. See the code example [PSoC™ 4 low power ganged sensor](#) and [AN92239 - Proximity sensing with CAPSENSE™](#) for details on ganged sensor implementation. A ganged sensor has different tuning parameters because its properties are different compared to considering the sensors individually. Therefore, it should be considered as a single CSD button and tuned separately; see [Manual tuning](#). The ganged sensor is periodically scanned by using a watchdog timer (WDT); if the ganged sensor reports a touch event, enable the scanning of the actual widgets that need to be scanned. This is helpful in CAPSENSE™ designs that requires Wake on Touch modes. The procedure is similar to what is explained in [Figure 113](#). You can achieve very low system current while maintaining a good touch response, by properly tuning CAPSENSE™ and the wakeup interval. This technique could also be used with the CSX touchpad widget
2. If high-speed peripherals such as system timers and I²C are required, you can put the CPU to sleep mode instead of going to deep sleep mode
3. You can also add a shield hatch in the design, as explained in [Driven shield signal and shield electrode](#) to reduce the parasitic capacitance and therefore, the scan time. The scan time and power consumption is directly related; thus, the power consumption is reduced by lowering the scan time

Note: In PSoC™ 4000 devices, it is not recommended to enter Sleep mode if a CAPSENSE™ scan is in progress.

7 Design considerations

7.1.2 Synchronized scanning

In Fifth-Generation Low-Power CAPSENSE™ (MSCLP), the sensor scanning can be controlled using the External Frame Start feature. This allows scanning to be triggered by a pulse on the External Frame Start pin (ext_frm_start). This feature is available in PSoC™ 4000T.

This feature can be used to synchronize the scanning of multiple devices with MSCLP on-board or to synchronize with external periodic noise sources, such as LCDs.

External frame start pulse guidelines

Mentioned below are the characteristics of the External Frame Start signal for the proper operation of the external frame start feature.

1. **Scan trigger:** A scan will happen only when an external frame start signal is received after a scan_all_slots has been called in the application.

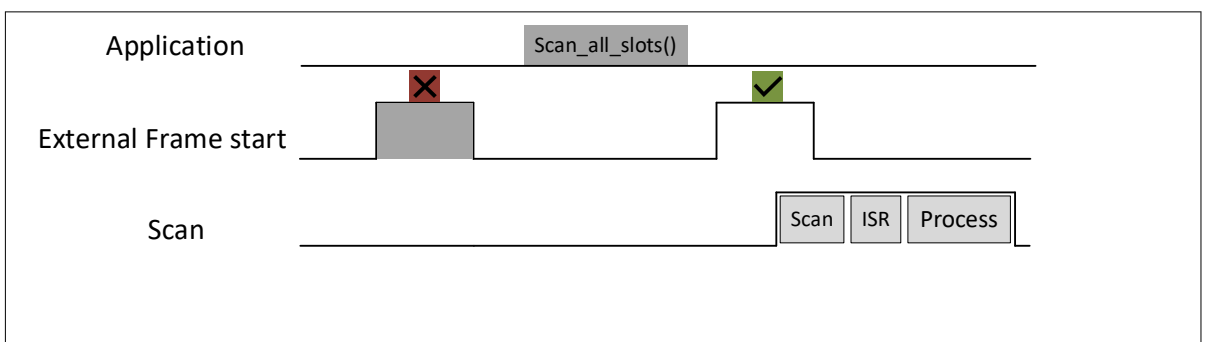

Figure 114 Scan trigger

2. **Pulse Type:** A clean rectangle wave
3. **Pulse Period:** The period of pulse that is interval between two subsequent pulses should not be lesser than the frame duration + MSC ISR duration + Processing duration

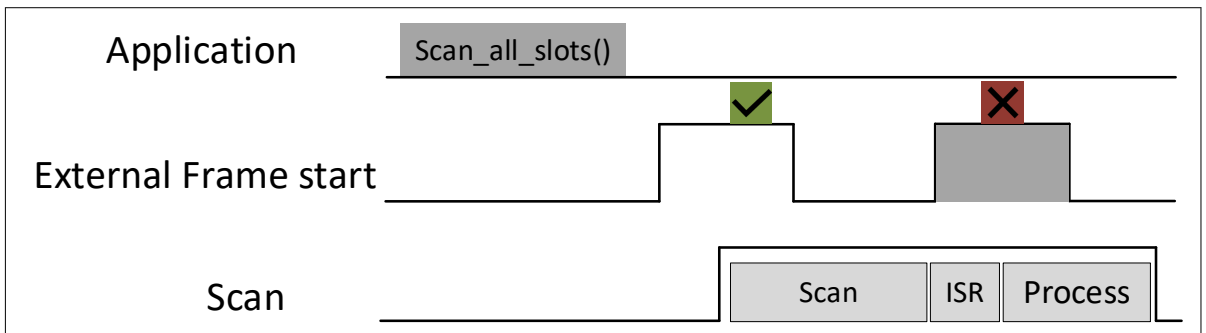

Figure 115 Pulse period

4. **Minimum Pulse Width:** The pulse should not be shorter than 2 ILO cycles

7 Design considerations

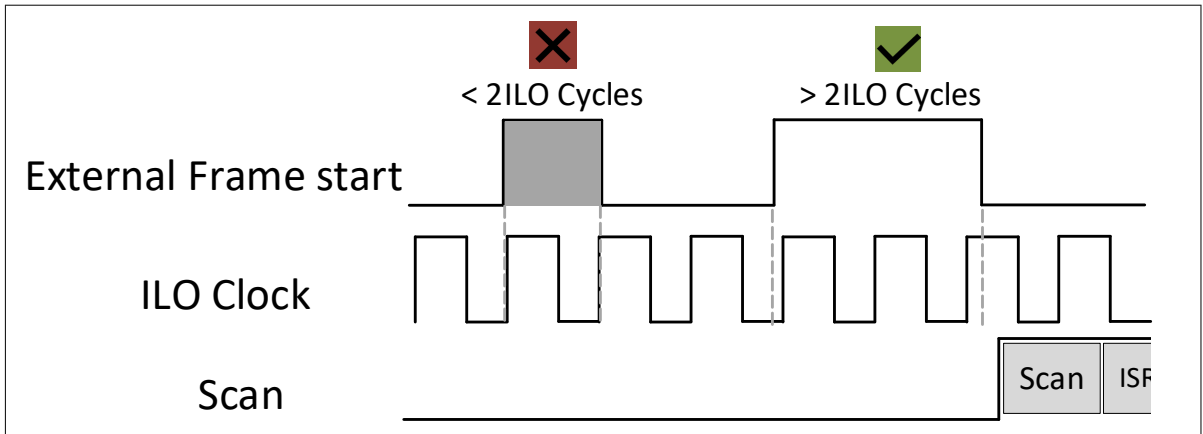

Figure 116 Minimum pulse width

- 5. **Max Pulse Width:** Should not be longer than scanning frame duration

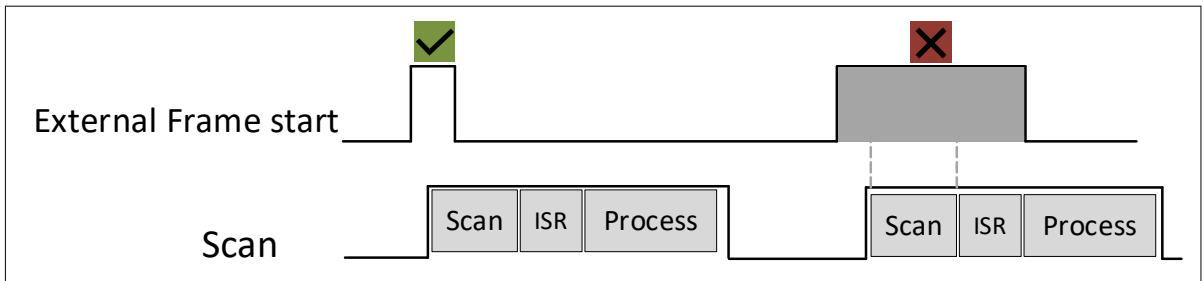

Figure 117 Max pulse width

- 6. **Sync interval (interval between the calling scan_all_slots() and the pulse):** Should be longer or equal 2 ILO cycles.

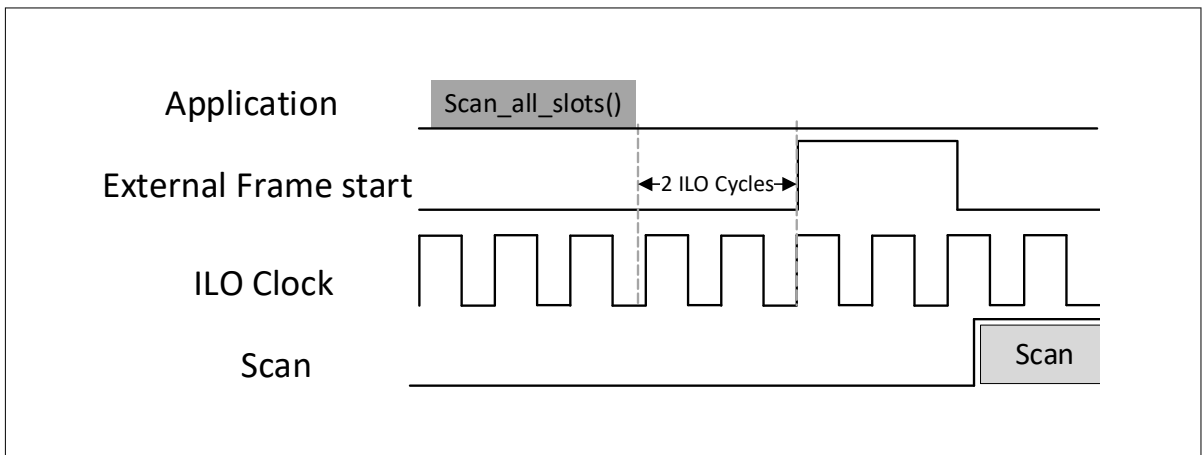

Figure 118 Sync interval

Conditioning the external frame start pulse

With the help of external frame start feature in MSLCP, scans can be synchronized with an LCD sync signal. If the external frame start signal does not comply with the guidelines mentioned in the **External Frame Start Pulse Guidelines** section, the signals will need to be conditioned. One way to condition the sync signal is using the TCPWM hardware present in the device. It receives the LCD sync signal (e.g., 60 Hz square wave) and generates the external_frame_start signal, with the appropriate width, as output.

7 Design considerations

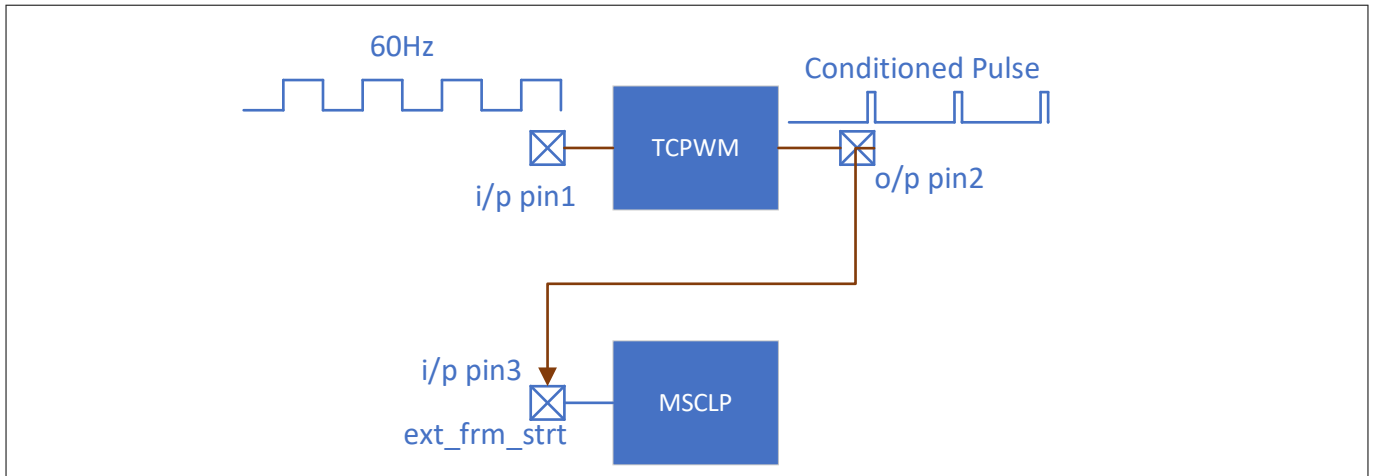

Figure 119 Using TCPWM to generate conditioned pulse

The TCPWM is configured as a single shot timer. The timer gets triggered by an external input pulse. This external input pulse is the LCD sync signal, and the output from the TCPWM is fed to the ext_frm_start pin of the MSCLP.

Three GPIOs and 1 TCPWM are used in this approach,

1. External Trigger input for the TCPWM
2. TCPWM line output
3. MSCLP ext_frm_strt pin

The output from the TCPWM needs to be wired and connected to the input of the ext_frm_strt pin.

7.2 Sensor construction

A capacitive sensor can be constructed using different materials depending on the application requirement. In a typical sensor construction, a conductive pad, or surface that senses a touch is connected to the pin of the PSoC™ using a conductive trace or link. This whole arrangement is placed below a non-conductive overlay material and the user interacts on top of the overlay.

Figure 120 shows the most common CAPSENSE™ sensor construction.

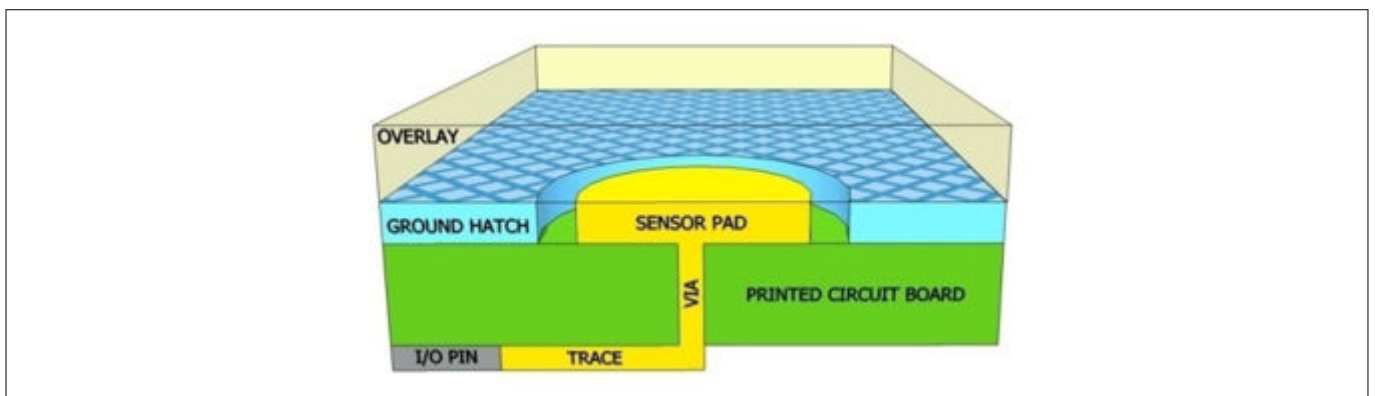

Figure 120 CAPSENSE™ sensor construction

The copper pads etched on the surface of the PCB act as CAPSENSE™ sensors. A nonconductive overlay serves as the touch surface. The overlay also protects the sensor from the environment and prevents direct finger contact. A ground hatch surrounding the sensor pad isolates the sensor from other sensors and PCB traces.

If liquid tolerance is required, you should use a shield hatch instead of the ground hatch. In this case, drive the hatch with a shield signal instead of connecting it to ground. See [Liquid tolerance](#) section for details.

7 Design considerations

The simplest CAPSENSE™ PCB design is a two-layer board with sensor pads and hatched ground plane on the top, and the electrical components on the bottom. [Figure 121](#) shows an exploded view of the CAPSENSE™ hardware.

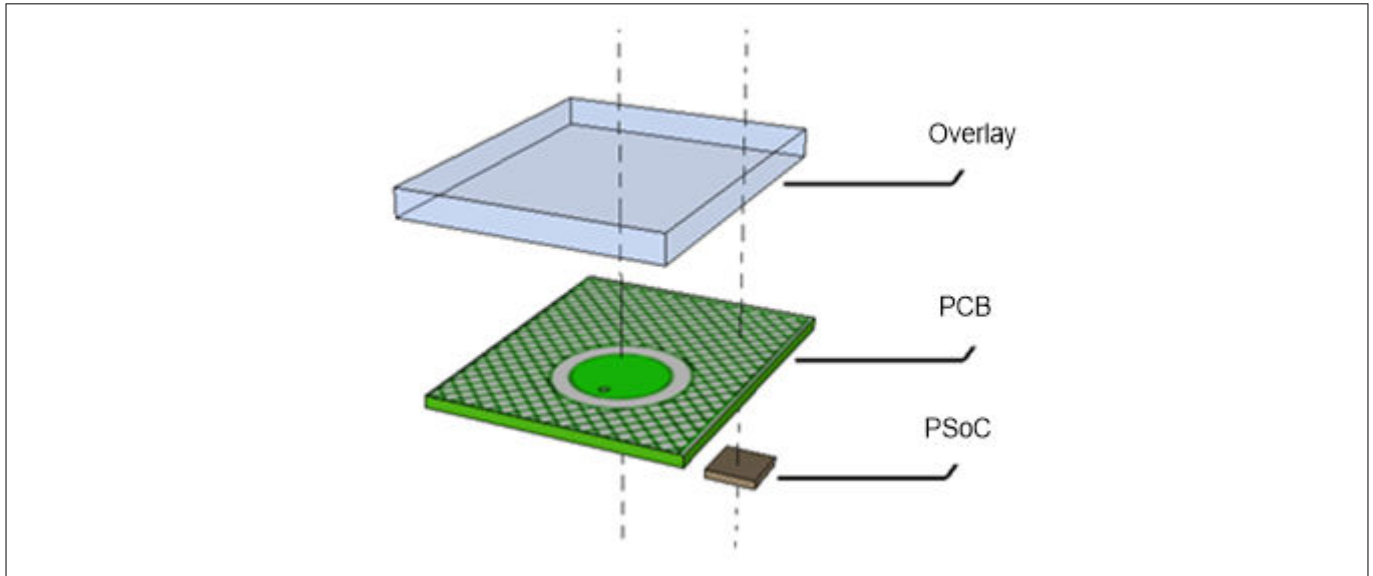

Figure 121 CAPSENSE™ hardware Sensor construction using springs as sensors

Sensors may also be constructed by using materials other than copper, such as indium tin oxide (ITO) or printed ink on substrates such as glass or a flex PCB. In some cases, springs can also be used as CAPSENSE™ sensors as [Figure 122](#) shows, to create elevated sensors that allow overlay to be placed at an elevated distance from the PCB. See [Getting started with CAPSENSE™ design guide](#) for PCB design considerations specific to spring sensors and other non-copper sensors such as ITO and printed ink.

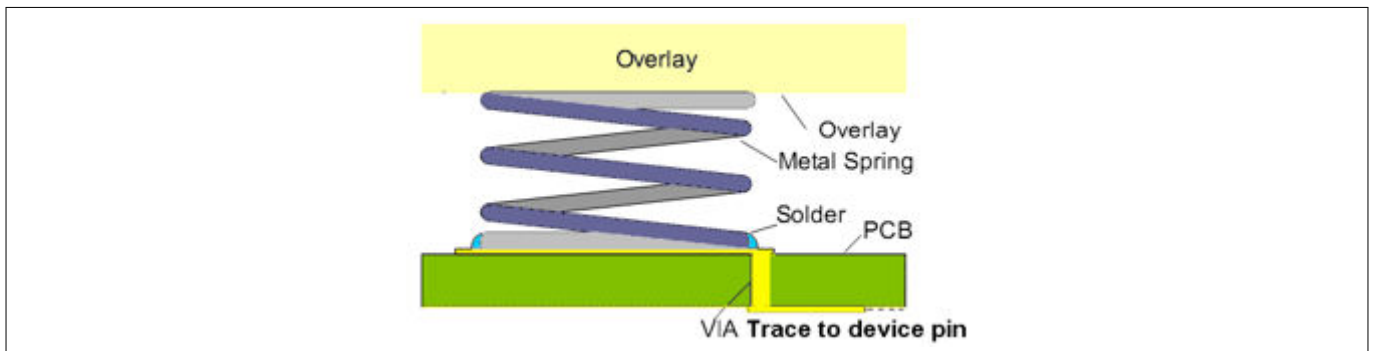

Figure 122 Sensor construction using springs as sensors

7.3 Overlay selection

7.3.1 Overlay material

The overlay is an important part of CAPSENSE™ hardware as it determines the magnitude of finger capacitance. The finger capacitance is directly proportional to the relative permittivity of the overlay material. See [Finger capacitance](#) for details.

[Table 28](#) shows the relative permittivity of some common overlay materials. Materials with relative permittivity between 2.0 and 8.0 are well suited for CAPSENSE™ overlay.

7 Design considerations

Table 28 Relative permittivity of overlay materials

Material	ϵ_r
Air	1.0
Formica	4.6 – 4.9
Glass (Standard)	7.6 – 8.0
Glass (Ceramic)	6.0
PET film (Mylar®)	3.2
Polycarbonate (Lexan®)	2.9 – 3.0
Acrylic (Plexiglas®)	2.8
ABS	2.4 – 4.1
Wood table and desktop	1.2 – 2.5
Gypsum (Drywall)	2.5 – 6.0

Note: Conductive materials interfere with the electric field pattern. Therefore, you should not use conductive materials for overlay. You should also avoid using conductive paints on the overlay.

7.3.2 Overlay thickness

Finger capacitance is inversely proportional to the overlay thickness. Therefore, a thin overlay gives more signal than a thick overlay. See [Finger capacitance](#) for details.

[Table 29](#) lists the recommended maximum thickness of acrylic overlay for different CAPSENSE™ widgets.

Table 29 Maximum thickness of acrylic overlay

Widget	Maximum thickness (mm) – 4th Generation CAPSENSE	Maximum thickness (mm) – 5th Generation CAPSENSE
Button	5	18
Slider	5 ¹⁾	18
Touchpad	0.5	3

1) For a 5 mm acrylic overlay, the SmartSense Component requires a minimum of 9 mm finger diameter for slider operation. If the finger diameter is less than 9 mm, Manual Tuning should be used.

Because [Finger capacitance](#) also depends on the dielectric constant of the overlay, the dielectric constant also plays a role in the guideline for the maximum thickness of the overlay. Common glass has a dielectric constant of approximately $\epsilon_r = 8$, while acrylic has approximately $\epsilon_r = 2.5$. The ratio of $\epsilon_r/2.5$ is an estimate of the overlay thickness relative to plastic for the same level of sensitivity. Using this rule of thumb, a common glass overlay can be about three times as thick as a plastic overlay while maintaining the same level of sensitivity.

In addition, avoid using very thin or no overlay. It is important to have a minimum overlay thickness in a CAPSENSE™ design for the following reasons:

1. An overlay provides protection from the environmental condition, prevents direct finger contact, and gives ESD protection. The overlay thickness should be small enough to give a good signal, and decided based on the button size and the strength to withstand ESD. See [AN64846 - Getting started with the CAPSENSE™](#)
2. For the CSD button, if there is no overlay the buttons will be over sensitive

7 Design considerations

3. For sliders, if there is no overlay, the raw count may saturate for the slider segments and may cause non-linear centroid response for slider. See [Slider design](#)
4. For the CSX sensor, it is recommended to have a minimum overlay thickness of 0.5 mm. If it is violated, sudden decrease in raw count is observed when a finger is placed on a sensor or a water drop falls on the Tx and Rx electrodes. See [Effect of grounding](#)

7.3.3 Overlay adhesives

The overlay must have a good mechanical contact with the PCB. You should use a nonconductive adhesive film for bonding the overlay and the PCB. This film increases the sensitivity of the system by eliminating the air gap between the overlay and the sensor pads. 3M™ makes a high-performance acrylic adhesive called 200 MP that is widely used in CAPSENSE™ applications. It is available in the form of adhesive transfer tapes; example product numbers are 467 MP and 468 MP.

7.4 PCB layout guidelines

PCB layout guidelines help you to design a CAPSENSE™ system with good sensitivity and high [Signal-to-noise ratio \(SNR\)](#).

7.4.1 Sensor C_P

In a CAPSENSE™ system design, the C_P of the sensor must be within the supported range of the device. You can find the supported C_P range in the [Component datasheet/middleware document](#). The main components of C_P are trace capacitance, sensor pad capacitance, and pin capacitance of the device. The pin capacitance is device-dependent (see the [Device datasheet](#)), so you can only design your sensor and trace capacitance to be able to meet the C_P criteria in the datasheet. The relationship between C_P and the PCB layout features is not simple. C_P increases with an increase in the sensor pad size and trace length and width, and with a decrease in the gap between the sensor pad and the ground hatch.

There are many ways to decrease the C_P :

- Decrease the trace length and width as much as possible. Reducing the trace length increases noise immunity
- Drive the hatch with a shield signal. See [Driven shield signal and shield electrode](#)

Reducing the sensor pad size is not recommended because it also reduces the finger capacitance. In some special cases, such as small sensor pad and very small trace length due to placement of the sensor pad close to the device, there is a possibility of the sensor C_P to be lower than the supported minimum C_P by the device. In that case, add a footprint of the capacitor across the sensor or any unused pin. If the C_P is identified to be lower than the supported range, place a 4.7 pF capacitor across the sensor or on the unused pin and gang the capacitor during the CAPSENSE™ scan, refer to the FAQ [I am unable to calibrate my system to 85 percent](#) for more details. This will increase the C_P of the sensor to the supported range.

If the sensor C_P is very high due to long traces or because of a nearby ground, use the mutual-capacitance sensing method so that the sensitivity is not degraded because of the high C_P value. The sensitivity of the CAPSENSE™ sensor in a mutual-capacitance sensing method is independent of the sensor C_P.

7.4.2 Board layers

Most applications use a two-layer board with the sensor pads and the hatched ground planes on the top side and all other components on the bottom side. PCBs that are more complex use four layers.

7 Design considerations

- FR4-based PCB designs perform well with board thickness ranging from 0.020 inches (0.5 mm) to 0.063 inches (1.6 mm).
- Flex circuits work well with CAPSENSE™ too. You can use flex circuits for curved surfaces. All PCB guidelines in this document also apply to flex. You should use flex circuits with thickness 0.01 inches (0.25 mm) or higher for CAPSENSE™. The high breakdown voltage of the Kapton® material (290 kV/mm) used in flex circuits provides built in ESD protection for the CAPSENSE™ sensors

7.4.3 Button design

7.4.3.1 Self-capacitance button design

The self-capacitance button has a single electrode and can have different shapes and size as recommended below.

Shape: You should use circular sensor pads for CAPSENSE™ buttons. Rectangular shapes with rounded corners are also acceptable. However, you should avoid sharp corners (<90°) since they concentrate electric fields.

Figure 123 shows recommended button shapes.

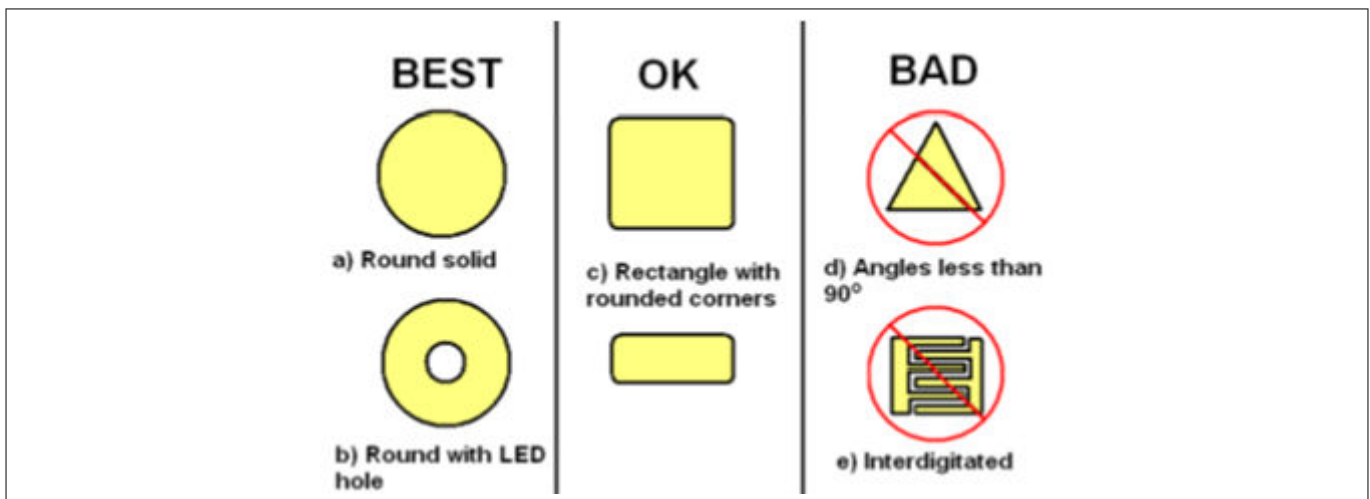

Figure 123 Recommended button shapes

Size: Button diameter should be 5 mm to 15 mm, with 10 mm suitable for most applications. A larger diameter is appropriate for thicker overlays.

Spacing: The width of the gap between the sensor pad and the ground hatch should be equal to the overlay thickness, and range from 0.5 mm to 2 mm. For example, if the overlay thickness is 1 mm, you should use a 1 mm gap. However, for a 3 mm overlay, you should use a 2 mm gap.

Select the spacing between two adjacent buttons such that when touching a button, the finger is not near the gap between the other button and the ground hatch, to prevent false touch detection on the adjacent buttons, as Figure 124 shows.

Figure 124 Spacing between buttons

7 Design considerations

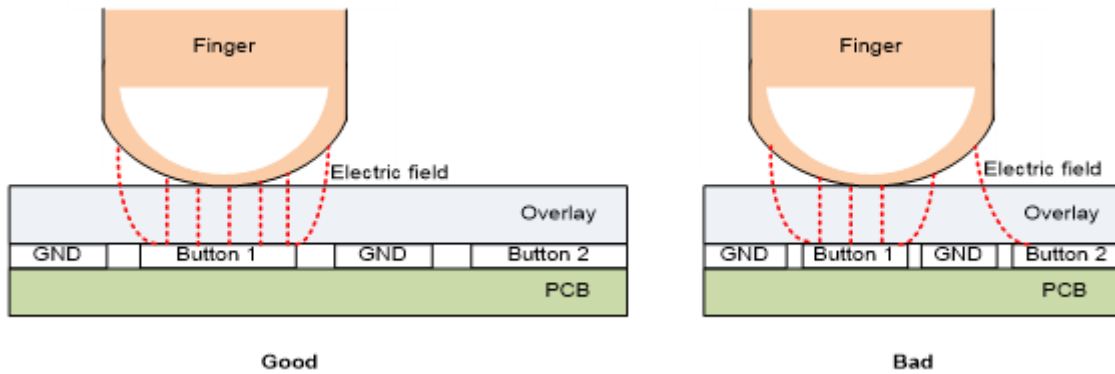

7.4.3.2 Mutual-capacitance button design

Mutual capacitance sensing measures the change in capacitive coupling between two electrodes. The sensor pattern should be designed in such a way that the finger disturbs the electric field between the Tx and Rx electrodes to a maximum extent. There are standard button patterns that could be used for the mutual capacitance button design and their parameters could be modified based on the application requirement. Fishbone pattern is one of the mutual capacitance patterns which give better performance in terms of SNR.

7.4.3.2.1 Fishbone pattern

Prongs or fishbone are standard shapes for mutual-capacitance buttons. The Tx forms a box or ring around the button for shielding Rx from noise. There are interlaced Tx and Rx prongs inside the border to form the electric field. Figure 125 shows an example of a two-prong fishbone sensor structure with top and bottom view with hatched ground. The gap between the outer wall of the Tx electrode and the coplanar hatch ground should be greater than the air-gap of Tx and Rx electrodes. The reference plane (PCB bottom layer) of the Fishbone structure should have void region as shown in Figure 125.

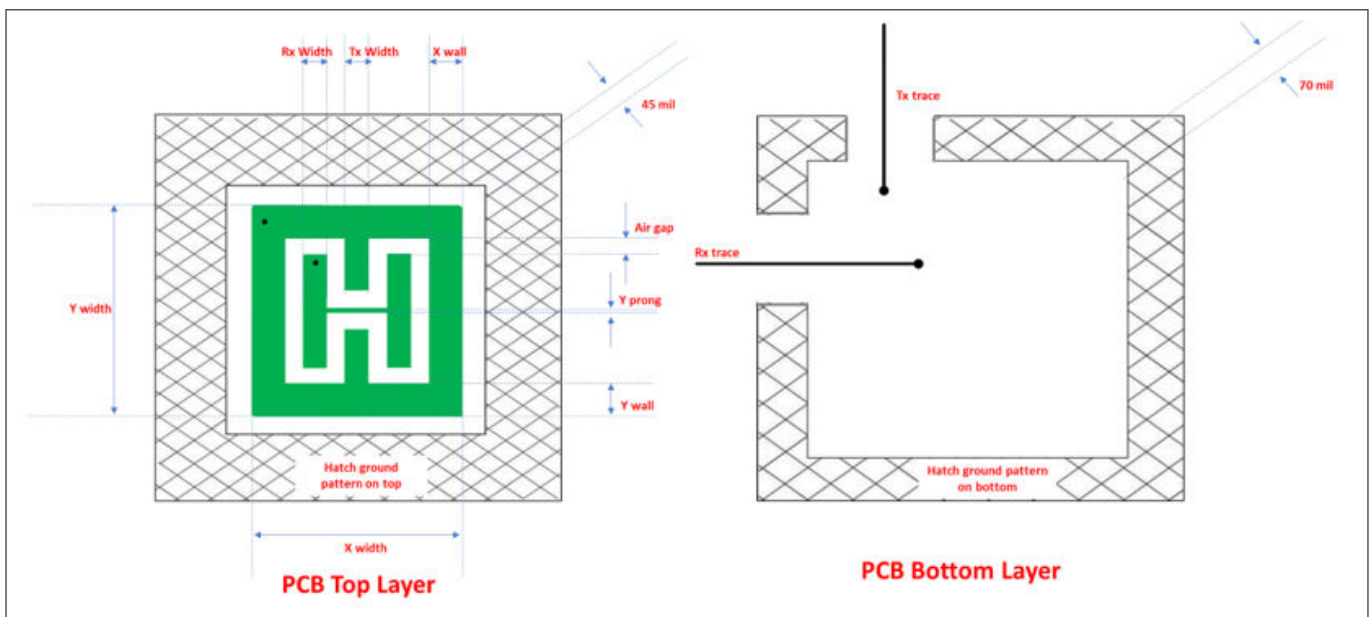

Figure 125 CSX Fish bone button pattern with two Rx prongs

Table 30 lists the suggested fishbone button design parameters for some commonly used sensor sizes and overlay like glass and acrylic. As explained in section Sensor size, the recommended button size is to keep the button X and Y dimension close to the sum of expected user finger size and overlay thickness. However, the

7 Design considerations

table lists multiple button sizes that you can chose from if you have constraints on available space on board or if you would like to have a bigger button for your application for ease of user interaction etc.

Also, note that for a given button size, the achievable SNR decreases with increased overlay thickness. Thus, if you plan to use thick overlays (approx. > 1 mm acrylic or 2 mm glass) ensure to avoid compromising on button size due to board space because that will further limit the button SNR performance. Ensure to use bigger buttons (>= biggest expected finger size) for such thick overlays. And also, for small buttons better to have thin overlays for getting good SNR.

Table 30 Dimension of Fishbone buttons (all units in mm)

Button size (X-size, Y-size) (mm)	Number of Rx-prongs	Air gap between Tx and Rx in mm	Tx width in mm	Rx width in mm	X-wall width in mm	Y-wall width in mm	Y prong in mm
5, 5	3	0.35	0.48	0.48	0.24	0.24	0.2
10,7	3	0.75	0.92	0.92	0.46	0.46	0.2
10,5	3	0.5	1.17	1.17	0.58	0.58	0.2
10,10	2	0.9	1.60	1.60	0.80	0.80	0.2
12, 12	2	1.3	1.70	1.70	0.85	0.85	0.2
13, 10	2	1.1	2.15	2.15	1.08	1.08	0.2
13, 13	2	1.5	1.75	1.75	0.88	0.88	0.2
15, 15	2	1.7	2.05	2.05	1.03	1.03	0.2
17, 17	2	2.3	1.95	1.95	0.98	0.98	0.2
20, 13	2	1.8	3.20	3.20	1.60	1.60	0.2
25, 13	2	2	4.25	4.25	2.13	2.13	0.2

The above button design parameters in [Table 30](#) ensure a good SNR performance if you follow the schematics and layout guidelines in this chapter.

Note: In case if you expect a higher external noise in the design and for other complex cases you can contact [Technical support](#) for any assistance in the button design. Refer to the section [Noise in CAPSENSE™ system](#) for more details about the external noise. And in the design if you expect a low C_M then follow the guidelines mentioned in the section [I am observing a low \$C_M\$ for my CSX button](#) for mitigating it.

7.4.3.2.2 Button design for arbitrary shapes and dimensions

[Figure 126](#) shows the different orientation of Rx prongs in the Fish bone pattern, in Button A the Rx prong is perpendicular to the side of the button with larger dimension and in Button B the Rx prongs is parallel to the side of the button with larger dimension. Orientation of Rx prongs like in Button A results in optimized button pattern compared to Button B. Thus, it is always recommended to have Rx prongs perpendicular to the side of the button with larger dimension. Thus if you need a 10x13 mm button, then simply use the 13x10 mm button from [Table 29](#) and rotate it 90° to get 13x10 mm [Noise in CAPSENSE™ system](#) button pattern as shown in [Figure 126](#).

7 Design considerations

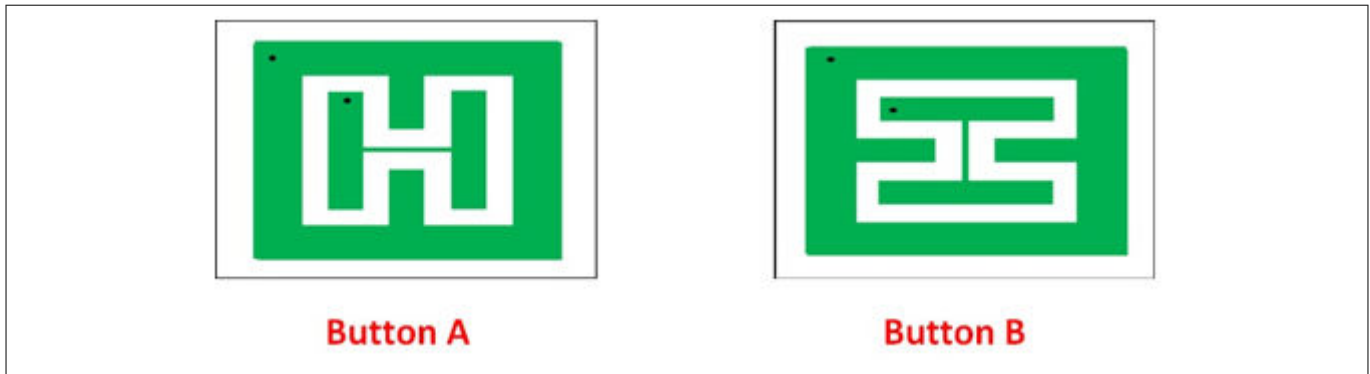

Figure 126 Orientation of Rx prongs

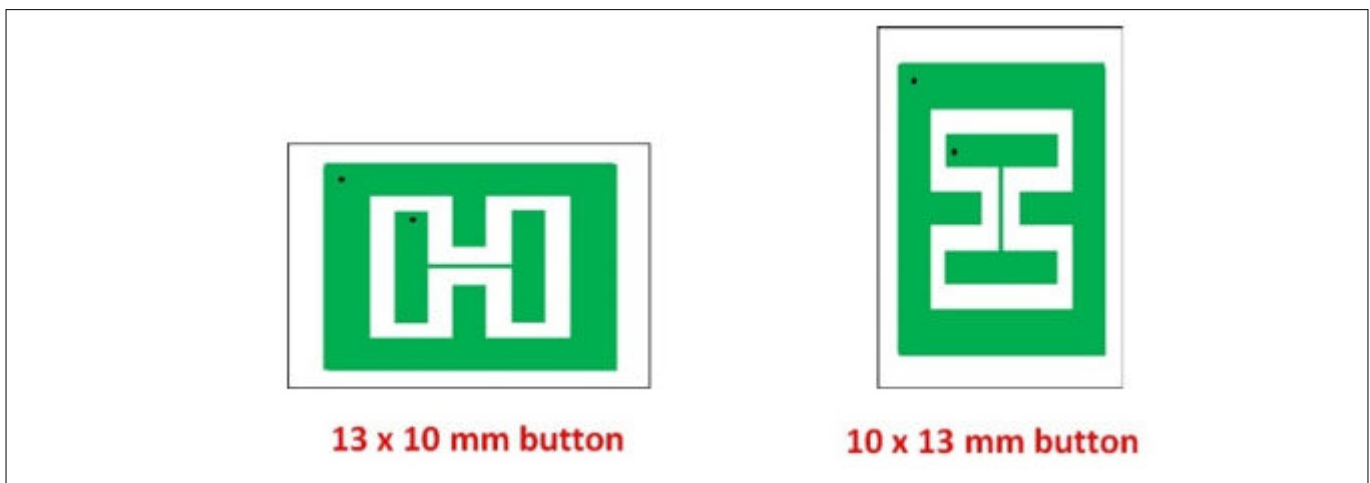

Figure 127 Rotating the button 90 deg to get the desired button dimension

There may be some design where you need a different button shape than the recommended rectangular, like an oval or circular shape etc. The below steps explain how to construct the button with nonstandard shape from the standard Fish bone pattern.

- First select the Fishbone pattern (Rectangular shape for oval shape and Square button for circular shape) from Table 29 to cover the desired button shape
- Then in the user interface or above the overlay print button shape with required dimension over the fishbone pattern as shown in Figure 128

Mutual capacitance buttons designed using this method have some oversensitive area or less sensitive outside the button shape as shown in the below figures, this could be mitigated by properly tuning the software thresholds of the mutual capacitance button. The below figure shows an example of a circular button made using a square fishbone pattern.

7 Design considerations

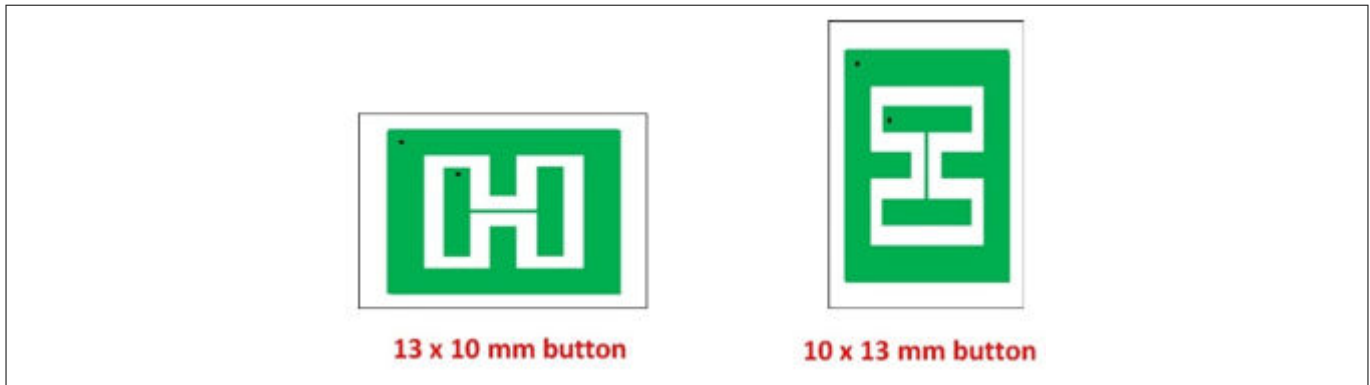

Figure 128 Arbitrary shape button design based on arbitrary pattern

If you want a pattern that is not present in Table 29, you can obtain the button parameters by following few steps. For example, if you want a 19x19 pattern, choose the pattern that is close to the required pattern from Table 29 like 17x17, and scale the air gap between Tx and Rx with respect to the button areas. For example:

$$New_{gap} = TxRx_{gap} \times \left(\frac{ButtonArea_{desired}}{ButtonArea_{reference}} \right)$$

Where, ButtonArea=X x Y dimension of the sensor.

Compute the Tx, Rx width and Tx wall based on the assumption below and by considering the New_{gap} as obtained above. The obtained values of the button design parameters are shown in Table 30. Refer to the Figure 125 to understand the description of the button design parameters.

$$Tx_{width} = Rx_{width}$$

$$Tx_{wall} = \frac{Tx_{width}}{2}$$

Table 31 Button parameter for 19 X 19 button form 17 X 17 button

Button size (X-size, Y-size) (mm)	Number of Rx-prongs	Air gap between Tx and Rx in mm	Tx width in mm	Rx width in mm	X-wall width in mm	Y-wall width in mm	Y prong in mm
17, 17	2	2.3	1.95	1.95	0.98	0.98	0.2
19,19	2	2.9	1.85	1.85	0.93	0.93	0.2

7.4.3.2.3 General recommendations on Fishbone pattern parameters

Sensor size

The sensor size is the XY dimension of the button, it is selected based on the board space availability, expected user finger size and overlay material and thickness. Sensor size selection also depends upon the number of required buttons on the PCB considering required button-to-button gap and space availability in the PCB. But if the space is not the constrain then choose higher button size which will result in getting a good SNR. Note that increasing the sensor size beyond a point will cause the SNR to saturate, this is because some of the electric field lines from Tx/Rx electrode do not interact with the finger as shown in Figure 129.

7 Design considerations

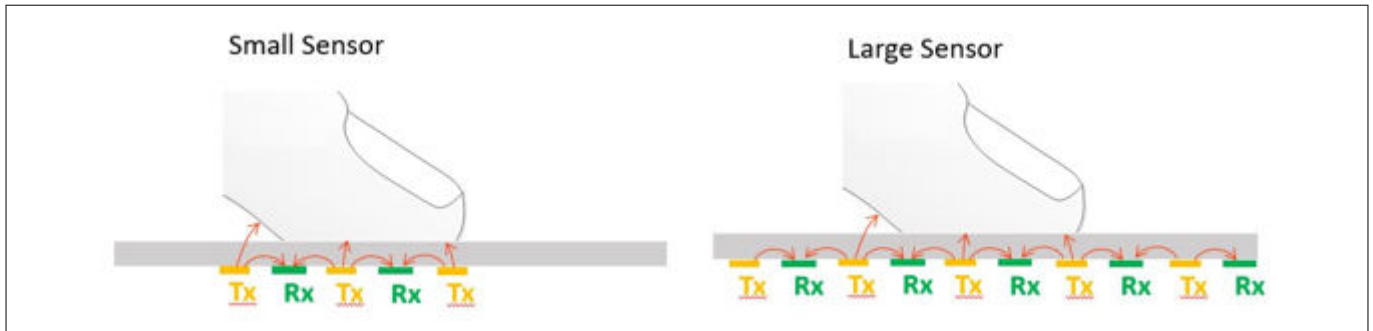

Figure 129 Interaction of electric field with the finger

The SNR of the button is decreased with usage of thick overlays. Thus, the recommended minimum sensor size is finger size plus overlay thickness to achieve a good SNR even with thick overlays. For example, the minimum sensor size recommended could be 13x10 mm, considering the finger size around 10mm in diameter and 3 mm overlay thickness. As mentioned in the [Button design for arbitrary shapes and dimensions](#) Rx prongs should be perpendicular to the side with large dimension.

Button spacing

The button spacing is the gap between the Tx wall of two buttons. It helps to prevent user error by isolating the buttons from each other and reduces the cross talk. It is recommended to keep a minimum of 8 mm spacing between the buttons this will ensure a good single touch and multi touch performance.

Overlay

The overlay thickness and overlay permittivity influences the SNR of the button and immunity towards the external noise such as ESD. Refer to the [Overlay selection](#) section for more details. It is recommended to keep the overlay thickness as minimum as possible which will help in getting a higher SNR for the button and it should be high enough to provide immunity towards ESD noise. In some cases, if the overlay thickness is more and you cannot avoid it due to mechanical design consideration. In such a case, for getting a better SNR use a mutual capacitance button with bigger size than the recommended size. Refer to the section [Sensor size](#) for selecting the minimum button dimension with respect to the overlay thickness. Using an overlay material with higher dielectric constant will also leads to higher SNR. So always use material with high dielectric constant when we use thick overlay. And also, for smaller buttons better to have thin overlays for getting good SNR.

Air gap between Tx and Rx electrode

The gap between the Tx and Rx electrode influences the mutual capacitance between the Tx and Rx electrode. Increasing the gap reduces the mutual capacitance. It is the most critical parameter in the Fishbone pattern design and the gap between the Tx and Rx electrode such that the mutual capacitance is above 750 fF.

Number of Rx-prongs

The number of Rx prongs influence the mutual capacitance between the Tx and Rx electrode, because increasing the number of Rx prongs decreases the gap between the Tx and Rx electrode for a given button size. Higher mutual capacitance implies higher electric field lines between Tx and Rx electrode. Thus, we get a higher signal when we touch the button, because the finger touch will disturb the electric field to a maximum extent. But higher C_M also increases the impact of external noise such as VDDA ripple noise. Thus, there is a tradeoff in selecting the number of Rx prongs to get a higher signal verses getting good noise immunity. The optimal number of Rx prongs is 2 for the Fishbone pattern (that is Fishbone pattern with a single Tx prong and two Rx prongs). The below figure shows the mutual capacitance button with three and one number of Rx prongs.

7 Design considerations

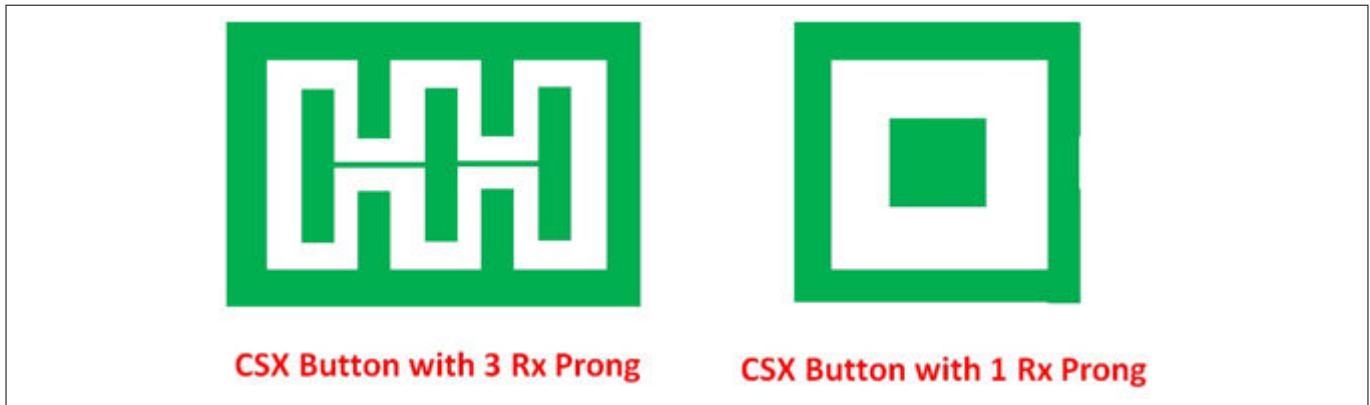
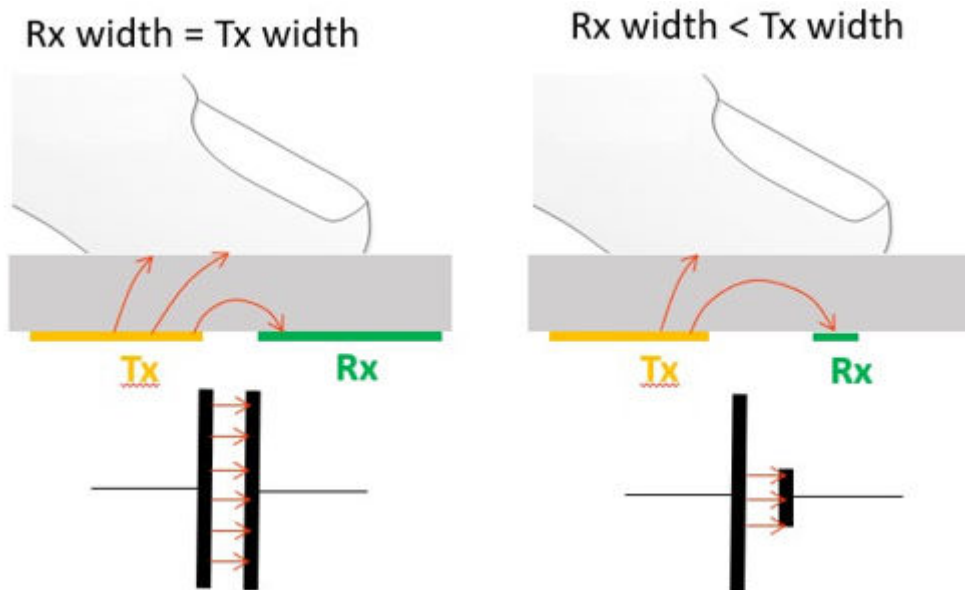

Figure 130 Mutual capacitance button with different number of prongs

Tx electrode and Rx electrode width

The Tx electrode and Rx electrode width influences the mutual capacitance between Tx and Rx electrode. Best signal response is achieved when Rx width/area is equal to Tx width/area in the case of less external noise in the system. The below figure shows the electric filed lines from Tx to Rx electrode with equal and unequal widths. Thus, from the below figure it is clear that having equal Tx and Rx width will eventually leads to higher change in C_M for a finger touch.

Figure 131 Effect of Tx and Rx width



In some cases, it is required to provide liquid tolerance to the mutual capacitance button as mentioned in section [Liquid tolerance for mutual-capacitance sensing](#). To achieve that we have to use a hybrid sensing technique with both CSX and CSD sensing method. In such a case the Tx or Rx electrode whichever is scanned in CSD technique should have a significant width so that it ensures a good signal for a finger touch.

Co planar ground

Presence of coplanar ground decreases the impact of noise in the system and it also provides good ground resulting in decreased signal disparity effect. It is recommended to have as much area surrounding the sensor with hatched pattern and connected it to device ground. Also follow the recommendations as mentioned in the layout and schematics guidelines in this chapter. Ground plane reduces the coupling of electric field lines to the

7 Design considerations

approaching finger, which decreases the change in mutual capacitance caused by a finger touch. It is suggested to avoid having ground plane underneath the sensor unless you expect strong coupling to a noise source present right below the sensor. Figure 125 shows the coplanar ground on the top and bottom layer of the PCB. The gap between the outer wall of the Tx electrode and the coplanar hatch ground should be greater than the air-gap of Tx and Rx electrodes.

Tx wall (X-wall and Y-wall width)

Tx wall act as a shield to the Rx electrode from noise. Wide Tx wall also reduces the effect of cross talk and the impact of Co-planar ground. It is recommended to keep the Tx wall width approximately equal to half of Tx electrode width. The below figure shows the effect of wider Tx wall, it increases the number of electric field lines reaching the finger from the Tx electrode by reducing the impact of Coplanar ground. The width of Tx wall can also be slightly increased in case Tx electrode is scanned as a CSD sensor as mentioned in section Liquid tolerance for mutual-capacitance sensing. An example 10x10 pattern with increased Tx wall is given in Table 31.

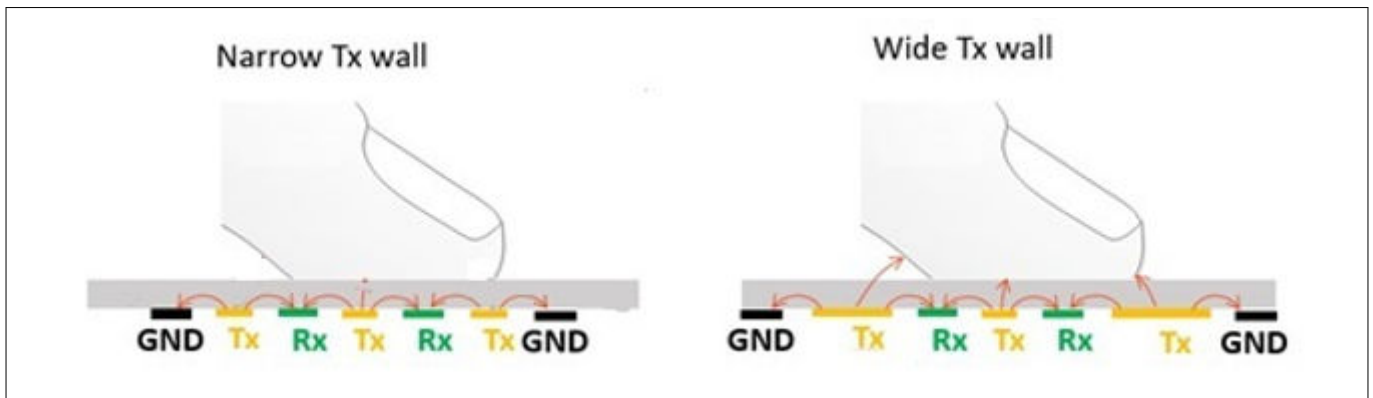

Figure 132 Effect of width of Tx wall

Table 32 Dimension of 10x10 button with increased Tx wall (all units in mm)

Button Size (X-Size, Y-Size) (mm)	Number of Rx-Prongs	Air Gap between Tx and Rx in mm	Tx Width in mm	Rx Width in mm	X-Wall Width in mm	Y-Wall Width in mm	Y Prong in mm
10, 10	2	0.8	1.2	1.2	1.5	1.6	0.2

7.4.4 Slider design

Figure 133 shows the recommended slider pattern for a linear slider and Table 33 shows the recommended values for each of the linear slider dimensions. A detailed explanation on the recommended layout guidelines is provided in the following sections.

7 Design considerations

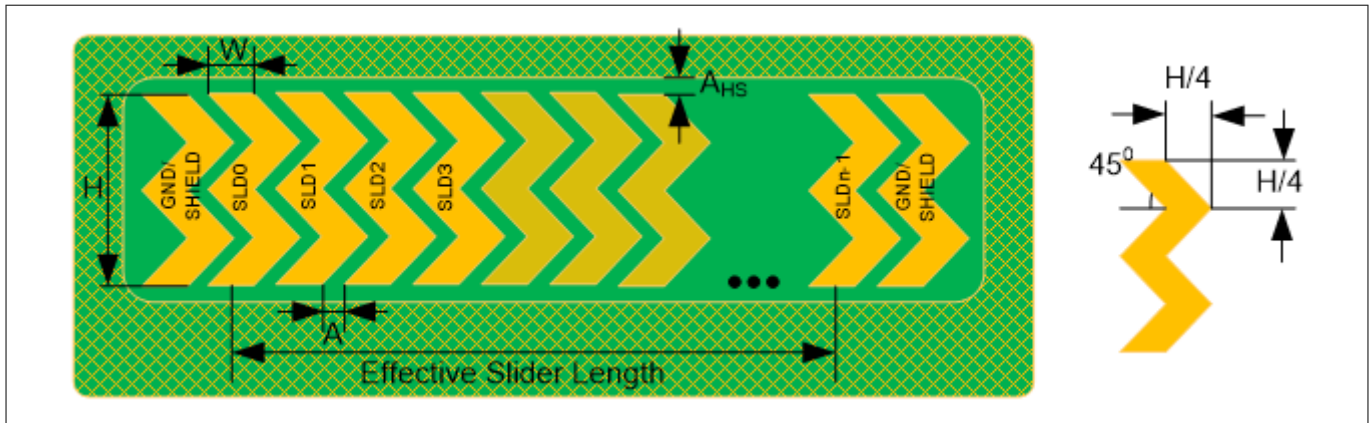

Figure 133 Typical linear slider pattern

Table 33 Linear slider dimensions

Parameter	Acrylic overlay thickness	Minimum	Maximum	Recommended
Width of the segment (W)	1 mm	2 mm	-	8 mm ¹⁾
	3 mm	4 mm	-	
	4 mm	6 mm	-	
Height of the segment (H)	-	7 mm ²⁾	15 mm	12 mm
Air gap between segments (A)	-	0.5 mm	2 mm	0.5 mm
Air gap between the hatch and the slider (A _{HS})	-	0.5 mm	2 mm	Equal to overlay thickness

- 1) The recommended slider-segment width is based on an average human finger diameter of 9 mm. See section [Slider-segment shape, width, and Air gap](#) for more details.
- 2) The minimum slider segment height of 7 mm is recommended based on a minimum human finger diameter of 7 mm. Slider height may be kept lower than 7 mm if the overlay thickness and CAPSENSE™ tuning is such that an [Signal-to-noise ratio \(SNR\)](#) (SNR) ≥ 5:1 is achieved when the finger is placed in the middle of any segment.

7.4.4.1 Slider-segment shape, width, and Air gap

A linear response of the reported finger position (that is, the centroid position) versus the actual finger position on a slider requires that the slider design is such that whenever a finger is placed anywhere between the middle of the segment SLD0 and middle of segment SLDn-1, other than the exact middle of slider segments, exactly two sensors report a valid signal ⁹⁾. If a finger is placed at the exact middle of any slider segment, the adjacent sensors should report a difference count = noise threshold. Therefore, it is recommended that you use a double-chevron shape as [Figure 133](#) shows. This shape helps in achieving a centroid response close to the ideal response, as [Figure 134](#) and [Figure 135](#) show. For the same reason, the slider-segment width and air gap (dimensions “W” and “A” respectively, as marked in [Figure 133](#)) should follow the relationship mentioned in [Equation 44](#).

⁹ Here, a valid signal means that the difference count of the given slider segment is greater than or equal to the noise threshold value.

7 Design considerations

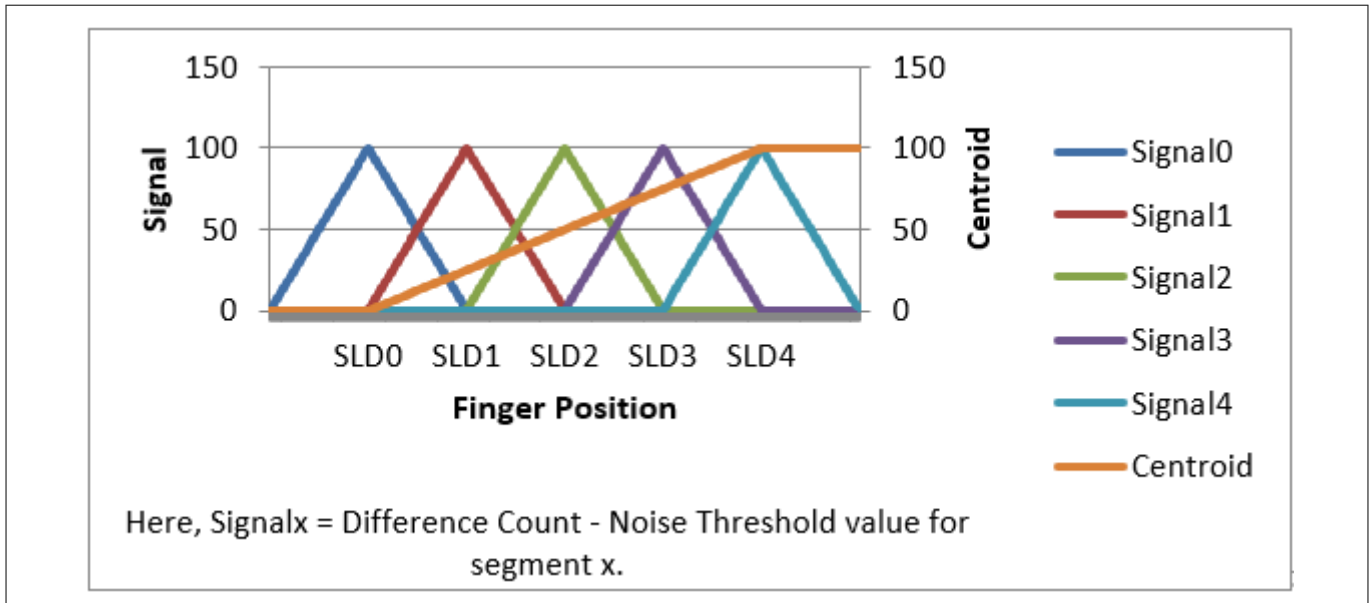

Figure 134 Ideal slider segment signals and centroid response

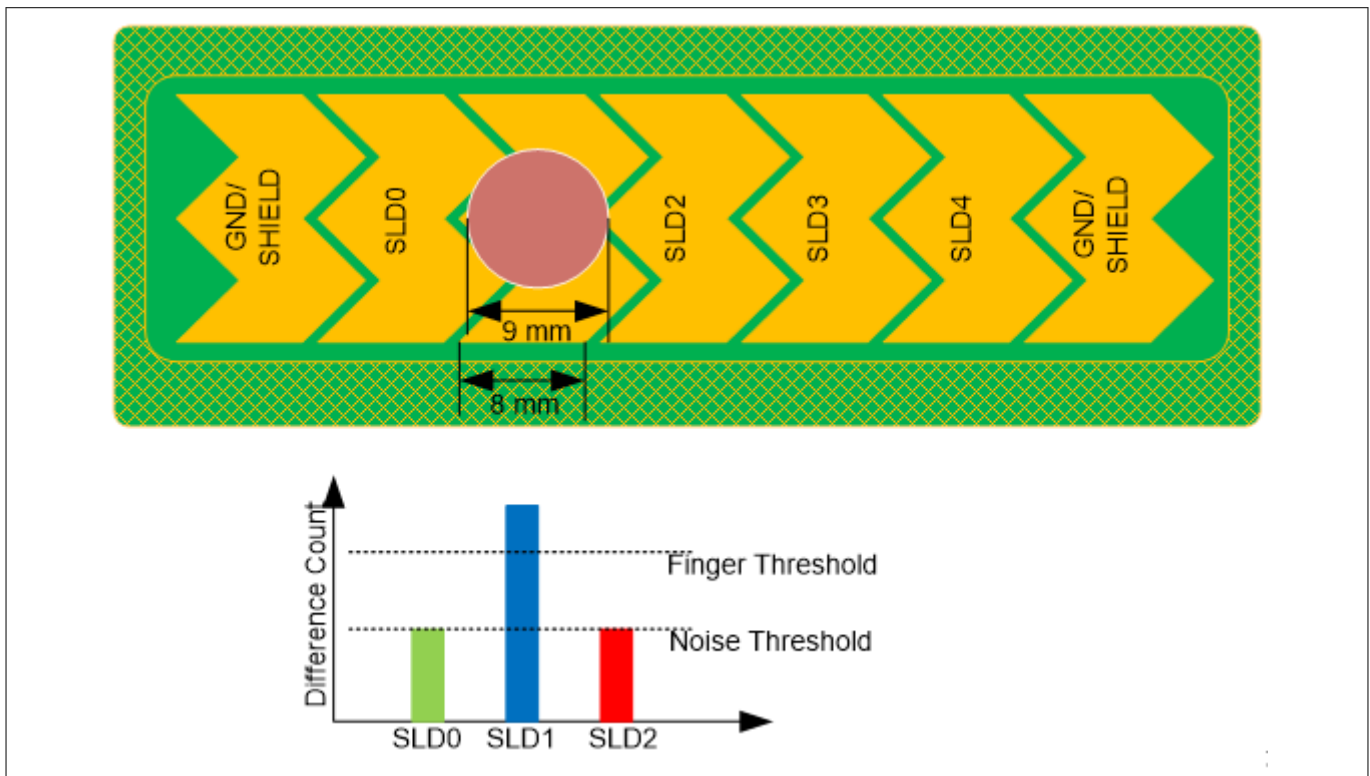

Figure 135 Ideal slider signals

$$W+2A = \text{finger diameter}$$

Equation 77 Segment width and air gap relation with the finger diameter

Typically, an average human finger diameter is approximately 9 mm. Based on this average finger diameter and Equation 77, the recommended slider-segment-width and air-gap is 8 mm and 0.5 mm respectively.

If the sum of *slider-segment width* and $2 * \text{air-gap}$ is lesser than *finger diameter*, as required according to Equation 77, the centroid response will be non-linear. This is because, in this case, a finger placed on the slider

7 Design considerations

will add capacitance, and hence valid signal to more than two slider-segments at some given position, as Figure 136 shows. Thus, calculated centroid position in Equation 78 will be non-linear as Figure 137 shows.

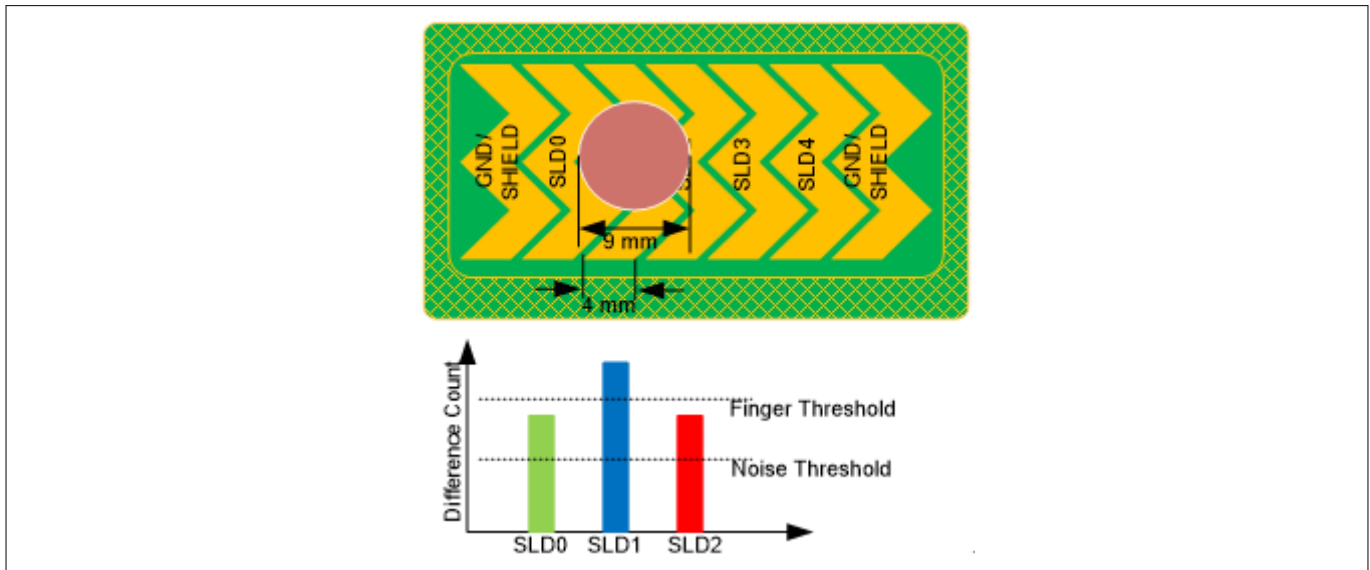

Figure 136 Finger causes valid signal on more than two segments when slider segment width is lower than recommended

$$\text{centroid position} = \left(\frac{S_{x+1} - S_{x-1}}{S_{x+1} + S_x + S_{x-1}} + x \right) \times \frac{\text{Resolution}}{(n - 1)}$$

Equation 78 Centroid algorithm used by CAPSENSE™ component in PSoC™ Creator

Where,

Resolution = API resolution set in the CAPSENSE™ component customizer

n = Number of sensor elements in the CAPSENSE™ component customizer

x = Index of element which gives maximum signal

Si = Different counts (with subtracted noise threshold value) of the slider segment

7 Design considerations

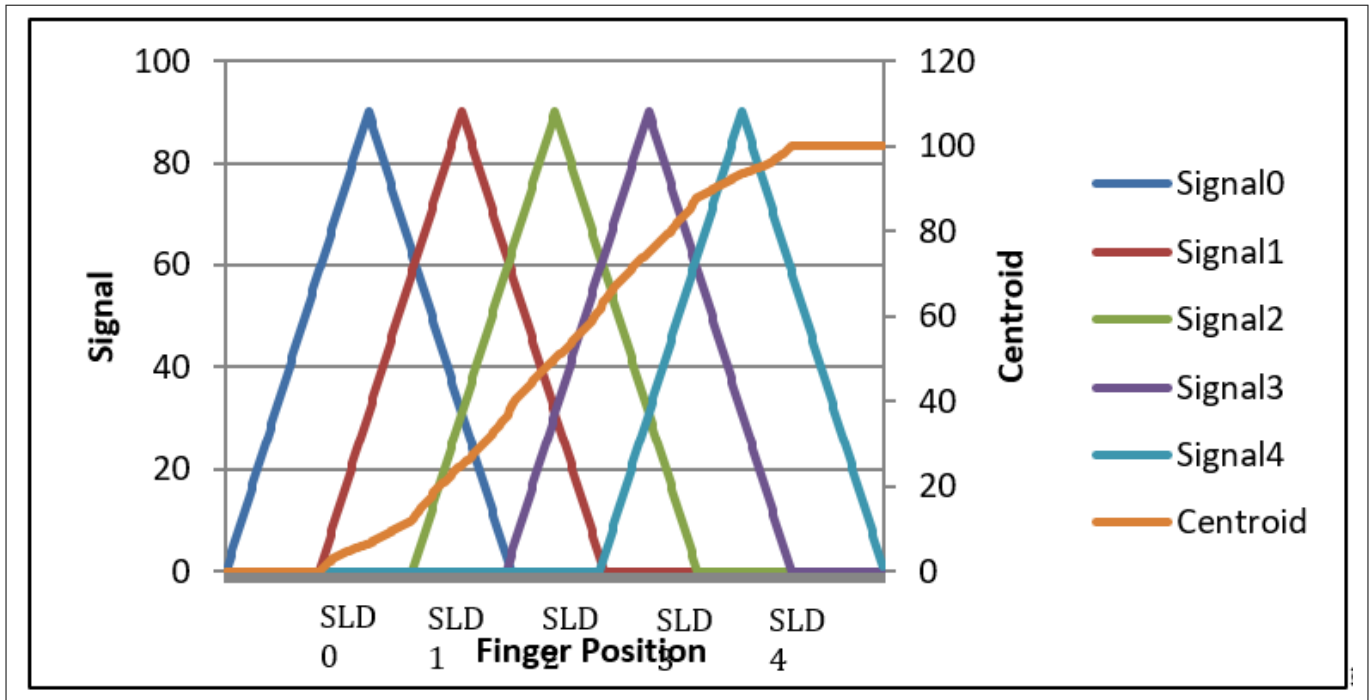

Figure 137 Nonlinear centroid response when slider segment width is lower than recommended

Note that even though a *slider-segment-width* value of less than *finger diameter* – 2 * *air-gap* provides a non-linear centroid response, as Figure 137 shows; it may still be used in an end application where the linearity of reported centroid versus actual finger position does not play a significant role. However, a minimum value of slider-segment-width must be maintained, based on overlay thickness, such that, at any position on the effective slider length, at least one slider-segment provides a **Signal-to-noise ratio (SNR)** of ≥ 5:1 (that is signal greater than or equal to the finger threshold parameter) at that position. If the slider-segment width is too low, a finger may not be able to couple enough capacitance, and therefore, none of the slider-segments will have a 5:1 SNR, resulting in a reported centroid value of 0xFFFF¹⁰⁾ in PSoC™ Creator as Figure 138 shows, and 0x0000¹¹⁾ in ModusToolbox™.

¹⁰⁾ The CAPSENSE™ Component in PSoC™ Creator reports a centroid of 0xFFFF when there is no finger detected on the slider, or when none of the slider segments reports a difference count value greater than the Finger Threshold parameter.

¹¹⁾ The CAPSENSE™ middleware in ModusToolbox™ reports a centroid of 0x0000 when there is no finger detected on the slider, or when none of the slider segments reports a difference count value greater than the Finger Threshold parameter.

7 Design considerations

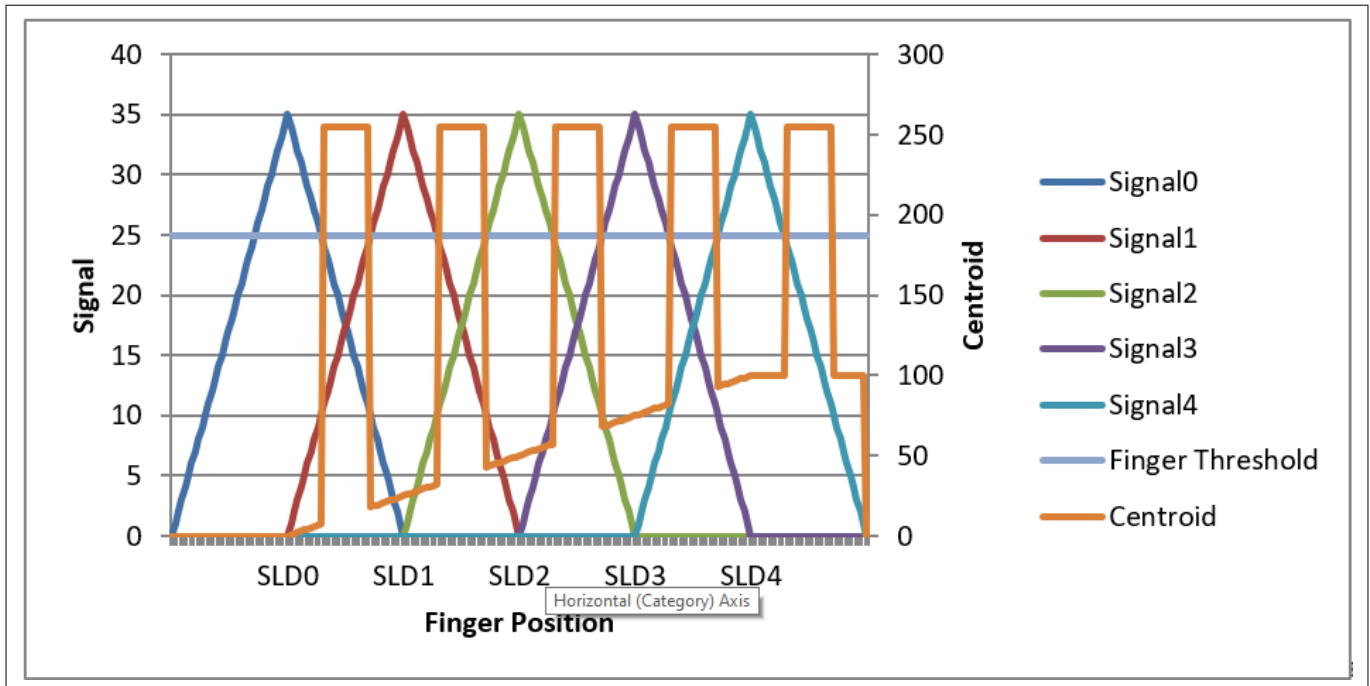

Figure 138 Incorrect centroid reported when slider-segment-width is too low

The minimum value of slider-segment width for certain overlay thickness values for an acrylic overlay are provided in [Table 33](#). For thickness values of acrylic overlays, which are not specified in [Table 33](#), [Figure 139](#) may be used to estimate the minimum slider-segment width. Very thin overlay or no overlay may cause a nonlinear centroid response due to saturation of raw count or due to high finger capacitance; centroid position may be detected before touching the slider. In these conditions, the CAPSENSE™ centroid algorithm will not be able to correctly estimate the finger position on the slider using [Equation 78](#). It is recommended to have the overlay thickness for the CSD sensor as mentioned in [#unique_270/unique_270_Connect_42_table_g1d_vz2_ftb](#).

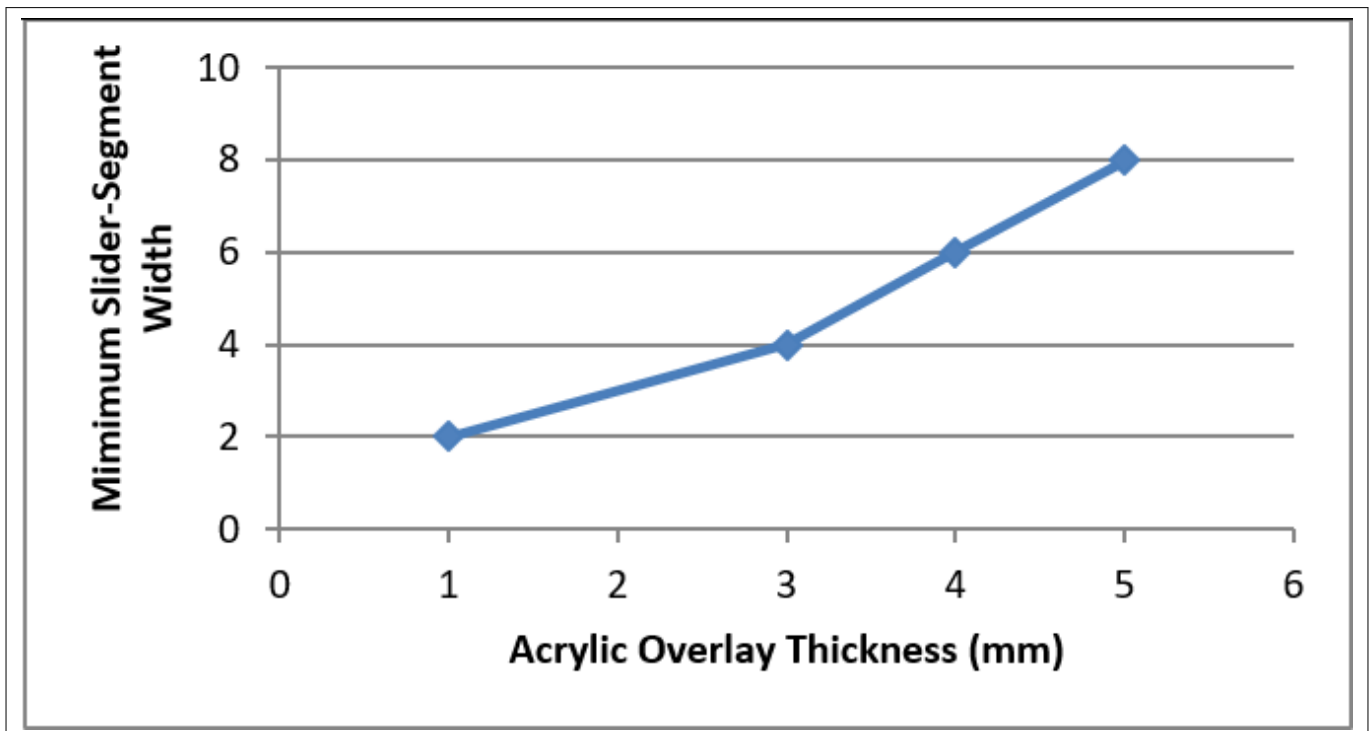

Figure 139 Minimum slider-segment width with respect to overlay thickness for an acrylic overlay

7 Design considerations

If the *slider-segment-width + 2 * air-gap* is higher than the *finger diameter* value as required in Equation 77, the centroid response will have flat-spots; that is, if the finger is moved towards the middle of any segment, the reported centroid position will remain constant as Figure 140 shows. This is because, as Figure 141 shows, when the finger is placed in the middle of a slider segment, it will add a valid signal only to that segment even if the finger is moved a little towards adjacent segments.

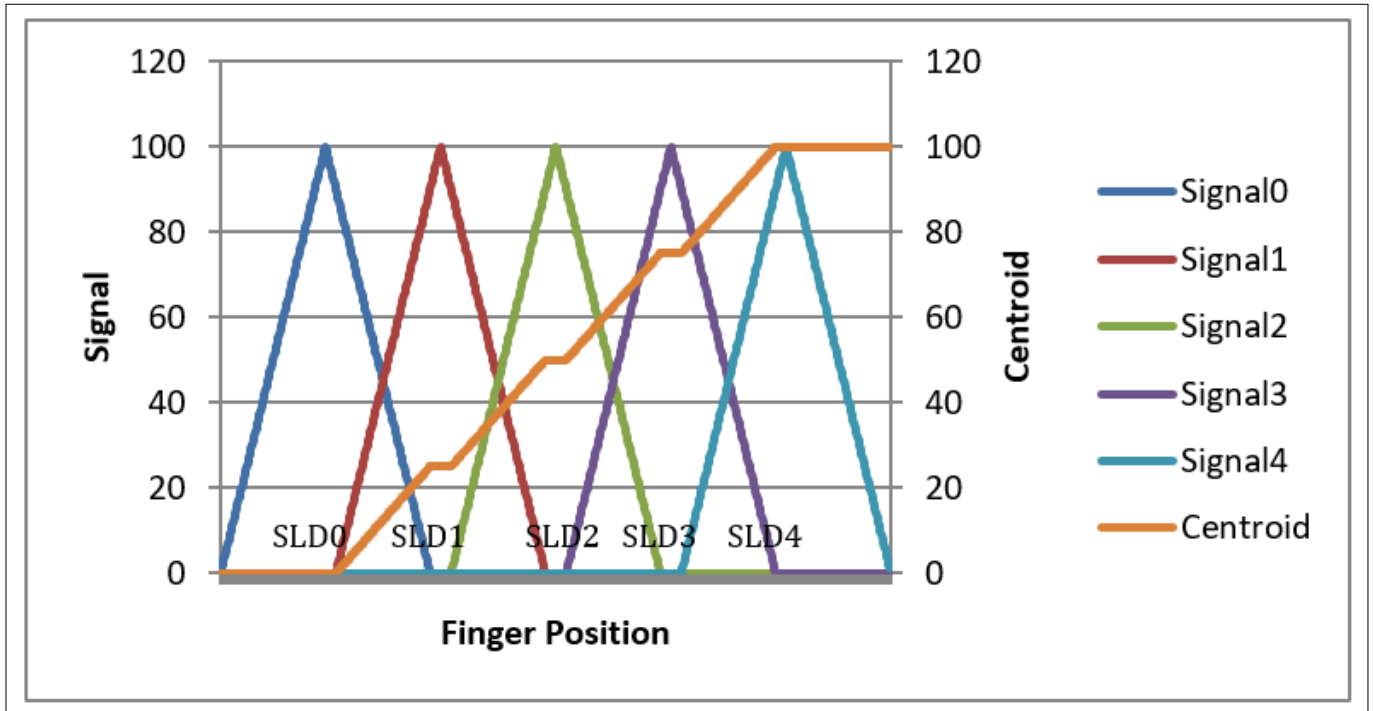

Figure 140 Flat-spots (nonresponsive centroid) when slider-segment width is higher than recommended

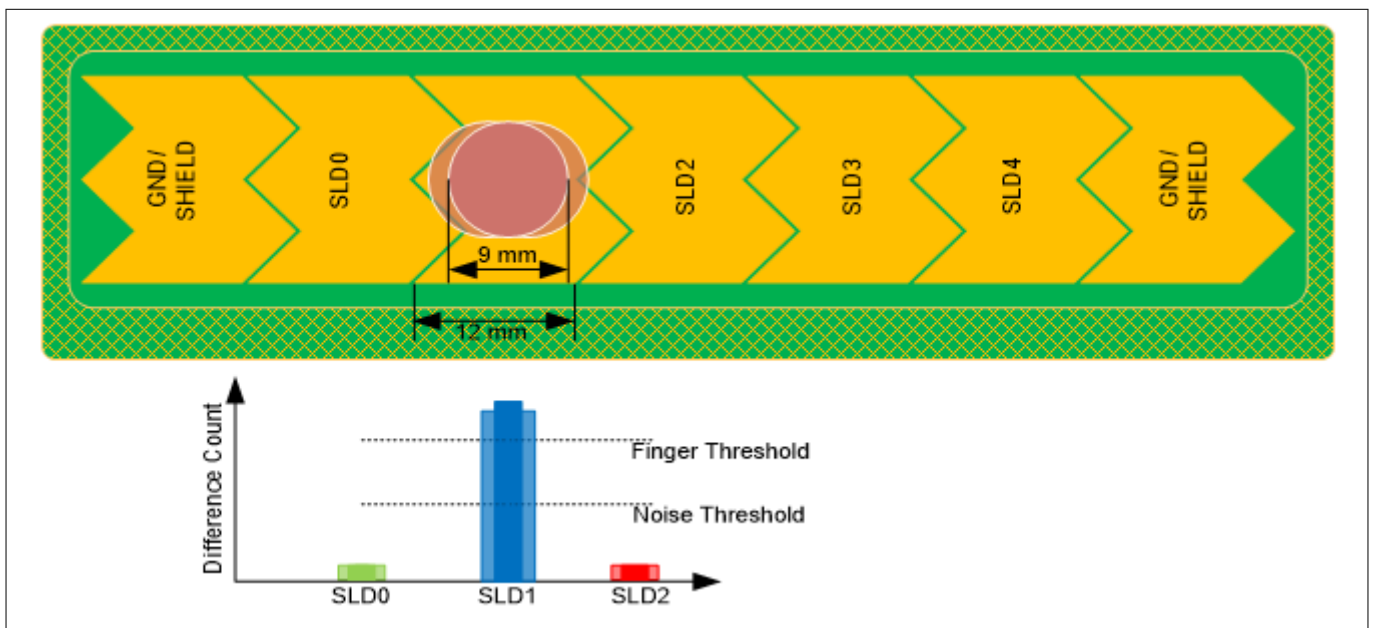

Figure 141 Signal on slider segments when slider-segment width is higher than recommended

Note that if the value of *slider-segment-width + 2 * air-gap* is higher than the *finger diameter*, it may be possible to increase and adjust the sensitivity of all slider segments such that even if the finger is placed in the middle of a slider segment, adjacent sensors report a difference count value equal to the noise threshold value (see

7 Design considerations

Figure 134); however, this will result in the hover effect – the slider may report a centroid position even if the finger is hovering above the slider and not touching the slider.

7.4.4.2 Dummy segments at the ends of a slider

In a CAPSENSE™ design, when one segment is scanned, adjacent segments are connected to either ground or to the driven- shield signal based on the option specified in the “Inactive sensor connection” parameter in the CAPSENSE™ CSD Component. For a linear centroid response, the slider requires all the segments to have the same sensitivity, that is, the increase in the raw count (signal) when a finger is placed on the slider segment should be the same for all segments. To maintain a uniform signal level from all slider segments, it is recommended that you physically connect the two segments at both ends of a slider to either ground or driven shield signal. The connection to ground or to the driven-shield signal depends on the value specified in the “Inactive sensor connection” parameter. Therefore, if your application requires an ‘n’ segment slider, it is recommended that you create n+2 physical segments, as Figure 133 shows.

If it is not possible to have two segments at both ends of a slider due to space constraints, you can implement these segments in the top hatch fill, as Figure 142 shows. Also, if the total available space is still constrained, the width of these segments may be kept lesser than the width of segments SLD0 through SLDn-1, or these dummy segments may even be removed.

If the two segments at the both ends of a slider are connected to the top hatch fill, you should connect the top hatch fill to the signal specified in the “Inactive sensor connection” parameter. If liquid tolerance is required for the slider, the hatch fill around the slider, the last two segments, and the inactive slider segments should be connected to the driven-shield signal. See the [Effect of liquid droplets and liquid stream on a self-capacitance sensor](#) section for more details.



Figure 142 Linear slider pattern when first and last segments are connected to top hatch fill

7.4.4.3 Deciding slider dimensions

Slider dimensions for a given design can be chosen based on following considerations:

1. Decide the required length of the slider (L) based on application requirements. This is same as the “effective slider length” as Figure 133 shows.
2. Decide the height of the segment based on the available space on the board. Use the maximum allowed segment height (15 mm) if the board space permits; if not, use a lesser height but ensure that the height is greater than the minimum specified in Table 33.
3. The slider-segment width and the air gap between slider segments should be as recommended in Table 33. The recommended slider-segment-width and air-gap for an average finger diameter of 9 mm is 8 mm and 0.5 mm respectively.
4. For a given slider length L, calculate the number of segments required by using the following formula:

7 Design considerations

$$\text{Number of segments} = \frac{\text{slider length}}{\text{slider segment width} + \text{airgap}} + 1$$

Equation 79 **Number of segments required for a slider**

Note: A minimum of two slider segments are required to implement a slider.

If the available number of CAPSENSE™ pins is slightly less than the number of segments calculated for a certain application, you may increase the segment width to achieve the required slider length with the available number of pins. For example, a 10.2 cm slider requires 13 segments. However, if only 10 pins are available, the segment width may be increased to 10.6 cm. This will either result in a nonlinear response as [Figure 140](#) shows, or a hover effect; however, this layout may be used if the end application does not need a high linearity.

Note: The PCB length is higher than the required slider length as [Figure 133](#) shows. PCB length can be related to the slider length as shown in [Equation 80](#).

$$\text{PCB length} = \text{Slider length} + 3 \times \text{slider segment width} + 2 \times \text{air gap}$$

Equation 80 **Relationship between minimum PCB length and slider length**

If the available PCB area is less than that required per this equation, you can remove the dummy segments. In this case, the minimum PCB length required will be as shown in [Equation 81](#).

$$\text{PCB length} = \text{Slider length} + \text{Slider segment width}$$

Equation 81 **Relationship between minimum PCB length and slider length**

7.4.4.4 **Routing slider segment trace**

A slider has many segments, each of which is connected separately to the CAPSENSE™ input pin of the device. Each segment is separately scanned and the centroid algorithm is applied finally on the signal values of all the segments to calculate the centroid position. The SmartSense algorithm implements a specific tuning method for sliders to avoid nonlinearity in the centroid that could occur due to the difference of C_p in the segments. However, the following layout conditions need to be met for the slider to work:

1. C_p of any segment should always be within the supported range of C_p as mentioned in the [Component datasheet](#)
2. C_p of the slider segment should be as close as possible. However, in the practical scenario C_p of each slider segment might vary because of differences in trace routing for each segment. The maximum allowed variation in the segment parasitic capacitance is 44% maximum C_p of the slider segment for an 85% IDAC calibration level. If the variation in C_p is beyond this limit then it may cause a change in the sensitivity among the slider segments leading to a non-linear slider response

Implement the following layout design rules to meet a good slider design with linear response.

- Design the shape of all segments to be as uniform as possible
- Ensure that the length and the width of the traces connecting the segments to the device are same for all the segments if possible
- Maintain the same air gap between the sensors or traces to ground plane or hatch fill

7 Design considerations

7.4.4.5 Slider design with LEDs

In some applications, it may be required to display the finger position by driving LEDs. You can either place the LEDs just above the slider segments or drill a hole in the middle of a slider segment for LED backlighting, as [Figure 143](#) shows. When a hole is drilled for placing an LED, the effective area of the slider segment reduces. To achieve an $SNR > 5:1$, you need to have a slider segment with a width larger than the LED hole size. See [Table 33](#) for the minimum slider width required to achieve an $SNR > 5:1$ for a given overlay thickness. Follow the guidelines provided in the [Crosstalk solutions](#) section to route the LED traces.

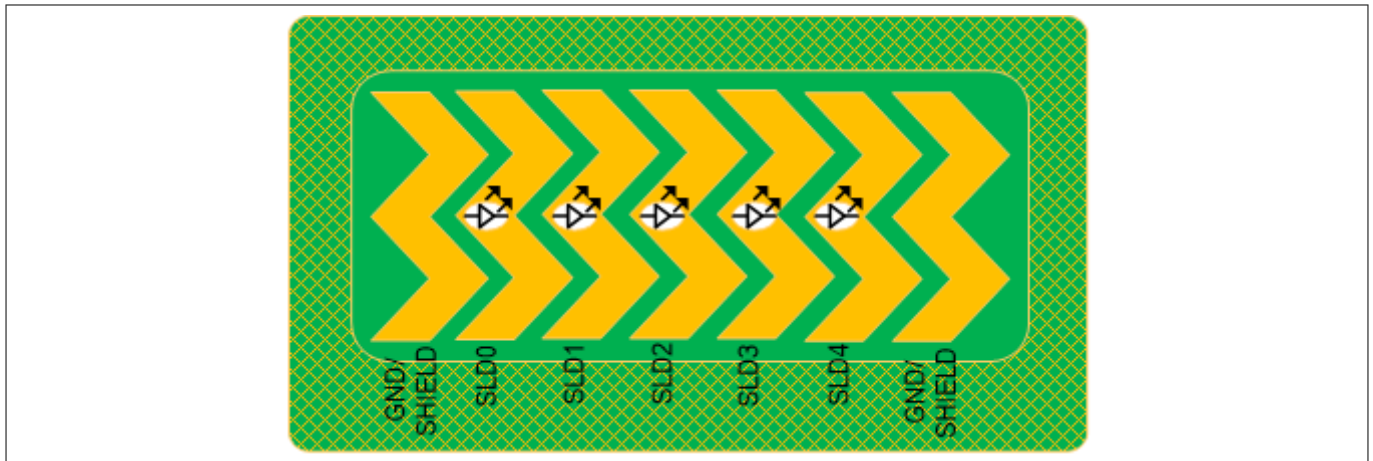

Figure 143 Slider design with LED backlighting

7.4.5 Sensor and device placement

Follow these guidelines while placing the sensor and the device in your PCB design:

- Minimize the trace length from the device pins to the sensor pad
- Mount series resistors within 10 mm of the device pins to reduce RF interference and provide ESD protection. See [Series resistors on CAPSENSE pins](#) for details
- Mount the device and the other components on the bottom layer of the PCB
- Avoid connectors between the sensor and the device pins because connectors increase C_p and noise pickup
- Button to Button distance (edge to edge) must be greater than 8 mm. If keys have less than 8 mm between them, there will be cross talk between the keys. Also, from a usability standpoint, it increases the risk of the user touching two keys at the same time. Key to key distance must be greater than 8 mm
- Spacing from a touch line to any metal should be greater than 5 mm. This includes the metal chassis, decorative chrome trim, screws, and so on
- Isolate or provide physical separation between CAPSENSE™ components and their signals from noisy subsystems such as transformers. A CAPSENSE™ system in general is sensitive to external noise

7.4.6 Trace length and width

Use short and narrow PCB traces to minimize the parasitic capacitance of the sensor. The maximum recommended trace length is 12 inches (300 mm) for a standard PCB and 2 inches (50 mm) for flex circuits. The maximum recommended trace width is 7 mil (0.18 mm). You should surround the CAPSENSE™ traces with a hatched ground or hatched shield with trace-to-hatch clearance of 10 mil to 20 mil (0.25 mm to 0.51 mm).

7 Design considerations

7.4.7 Trace routing

You should route the sensor traces on the bottom layer of the PCB, so that the finger does not interact with the traces. Do not route traces directly under any sensor pad unless the trace is connected to that sensor.

Do not run capacitive sensing traces closer than 0.25 mm to switching signals or communication lines. Increasing the distance between the sensing traces and other signals increases the noise immunity. If it is necessary to cross communication lines with sensor pins, make sure that the intersection is at right angles, as Figure 144 shows.

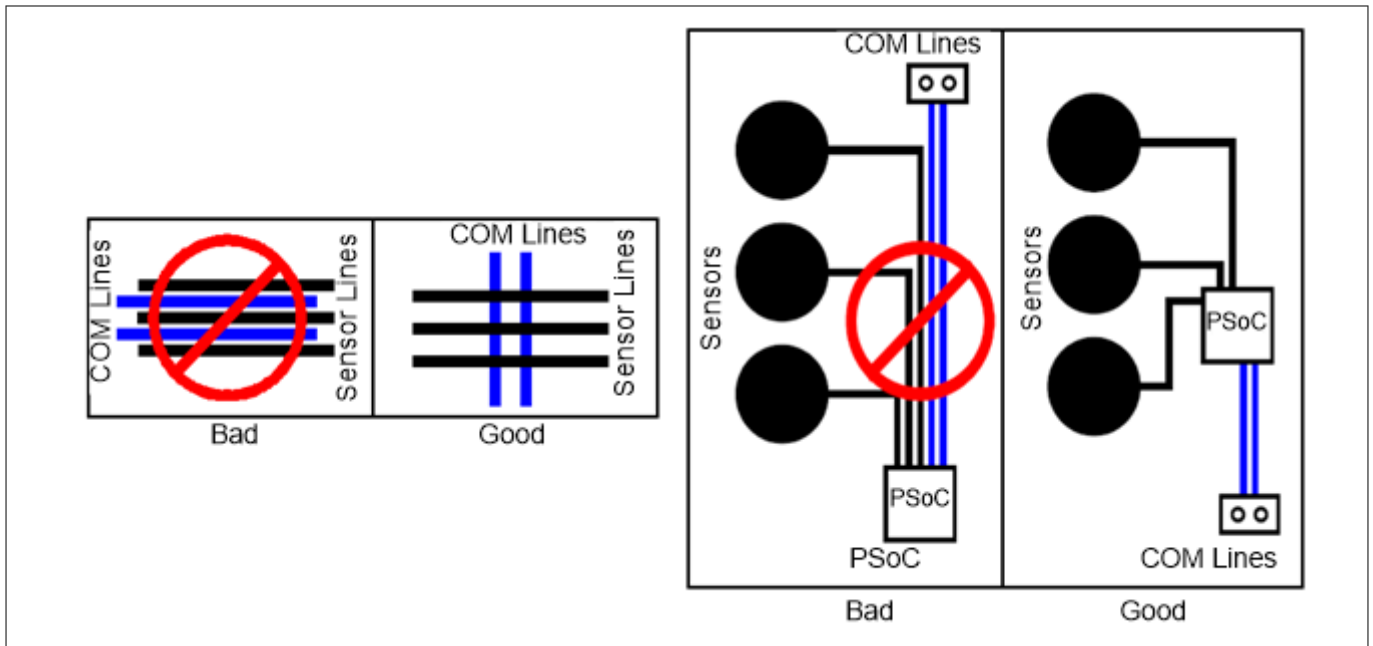

Figure 144 Routing of sensor and communication lines

If, due to spacing constraints, sensor traces run in parallel with high-speed traces such as I²C communication lines or Bluetooth® LE antenna traces, it is recommended to place a ground trace between the sensor trace and the high-speed trace as shown in Figure 145. This guideline also applies to the cross talk caused by CAPSENSE™ sensor trace with precision analog trace such as traces from temperature sensor to the PSoC™ device. The thickness of the ground trace can be 7 mils and the spacing from sensor trace to ground trace should be equal to minimum of 10 mils to reduce the C_p of the CAPSENSE™ sensor.

7 Design considerations

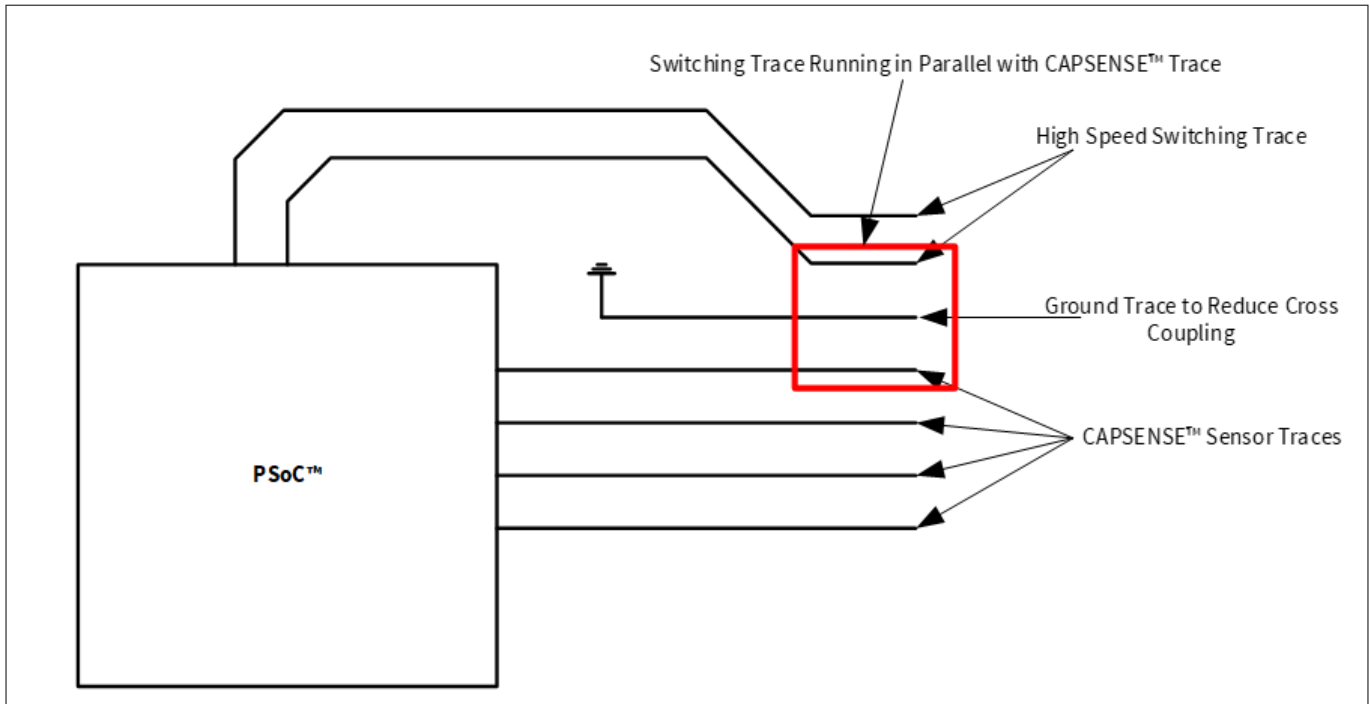

Figure 145 Reducing cross talk between high-speed switching trace and CAPSENSE™ trace

If a ground trace cannot be placed in between the switching trace and the CAPSENSE™ trace, the 3W rule can be followed to reduce the cross talk between the traces. The 3W rule states that “to reduce cross talk from adjacent traces, a minimum spacing of two trace widths should be maintained from edge to edge” as shown in Figure 146.

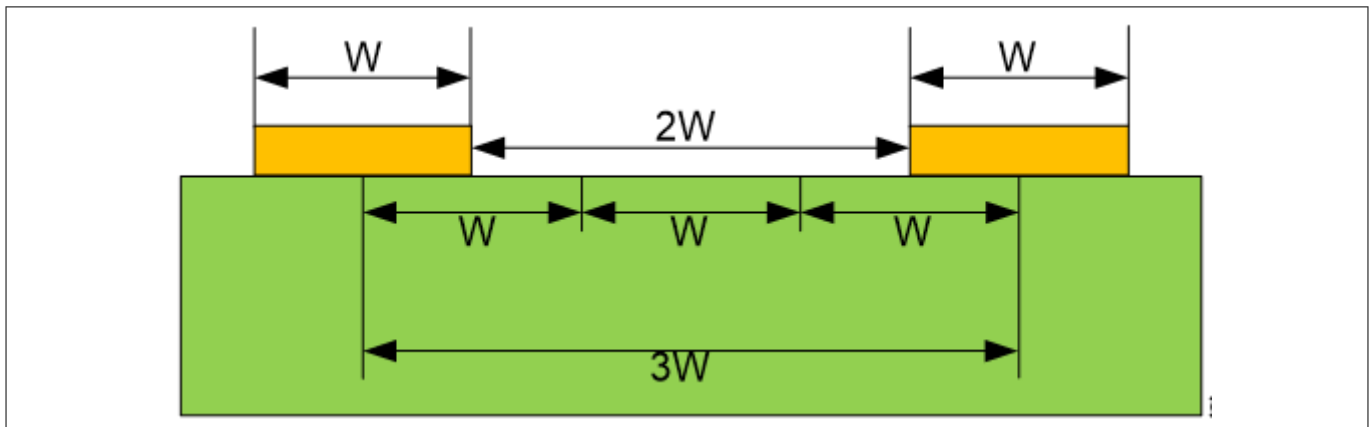

Figure 146 3W trace spacing to minimize cross talk

- Do not run Tx and Rx lines parallel to each other. The trace routing should be separated as much as possible
- If the layout constraints require Tx and Rx run parallel for short distances, the space between Tx and Rx should be greater than the distance between Tx and Rx inside the key (2 times the Tx-Rx key spacing is preferred) or add ground between them
- Keep as much clearance around Rx as possible to prevent noise on the touch keys. It is critical to follow this guideline for spacing to power traces and LED lines (high speed switching, power). Ground should also follow this rule, but it is less critical. Ground will provide noise protection but will reduce key sensitivity
- For a given set of sensors, the number of Rx lines must be less than or equal to Tx lines. Rx lines are susceptible to noise, whereas Tx lines are relatively less susceptible

7 Design considerations

7.4.8 Crosstalk solutions

A common backlighting technique for panels is an LED mounted under the sensor pad so that it is visible through a hole in the middle of the sensor pad. When the LED is switched ON or OFF, voltage transitions on the LED trace can create crosstalk in the capacitive sensor input, creating noisy sensor data. To prevent this crosstalk, isolate CAPSENSE™ and the LED traces from one another as Trace routing section explains.

You can also reduce crosstalk by removing the rapid transitions in the LED drive voltage, by using a filter as Figure 147 shows. Design the filter based on the required LED response speed.

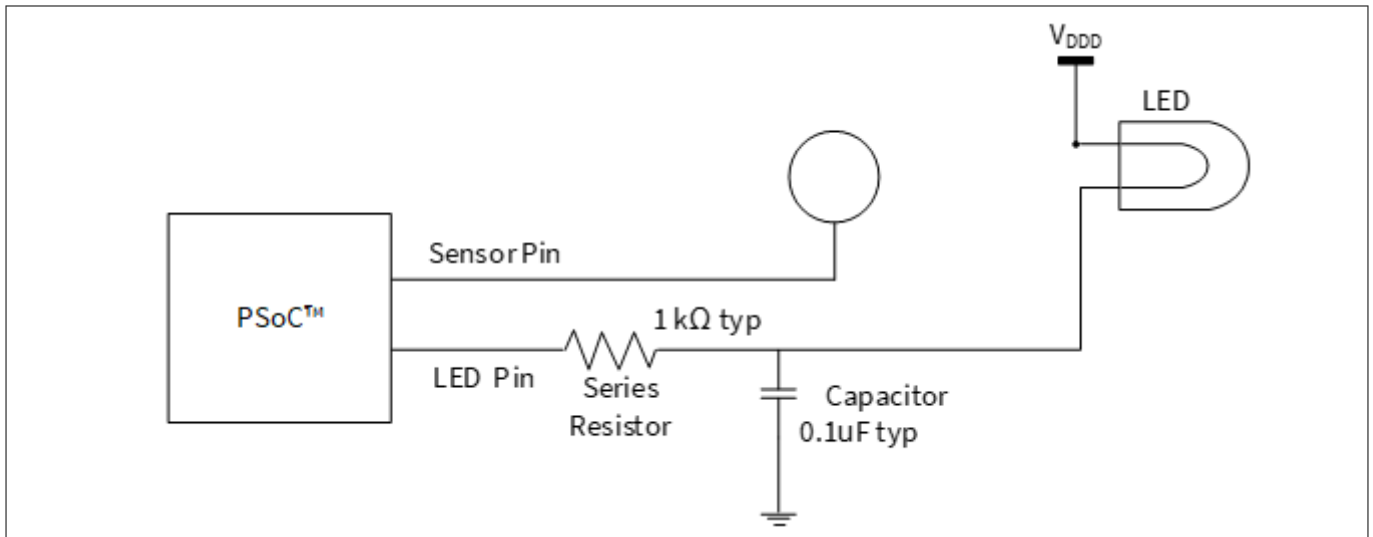

Figure 147 Reducing crosstalk

A guard trace is a ground trace running close to or above/below a TX/Rx line of a mutual-capacitance button. Guard traces can be used to protect sensor traces from noise if the layout does not allow for a ground hatch. Similar to ground hatch, guard traces add parasitic capacitance and reduce button sensitivity. Guard traces are usually needed on a case-by-case basis. Typical situations where guard traces have been used in the past include:

- Reduce cross talk
- Protect from noise of high-speed lines (I2C, SPI, UART) and toggling LED traces
- Border around the HMI or around an LCD

7.4.9 Vias

Use the minimum number of vias possible to route CAPSENSE™ signals, to minimize parasitic capacitance. Place the vias on the edge of the sensor pad to reduce trace length, as Figure 148 shows.

7 Design considerations

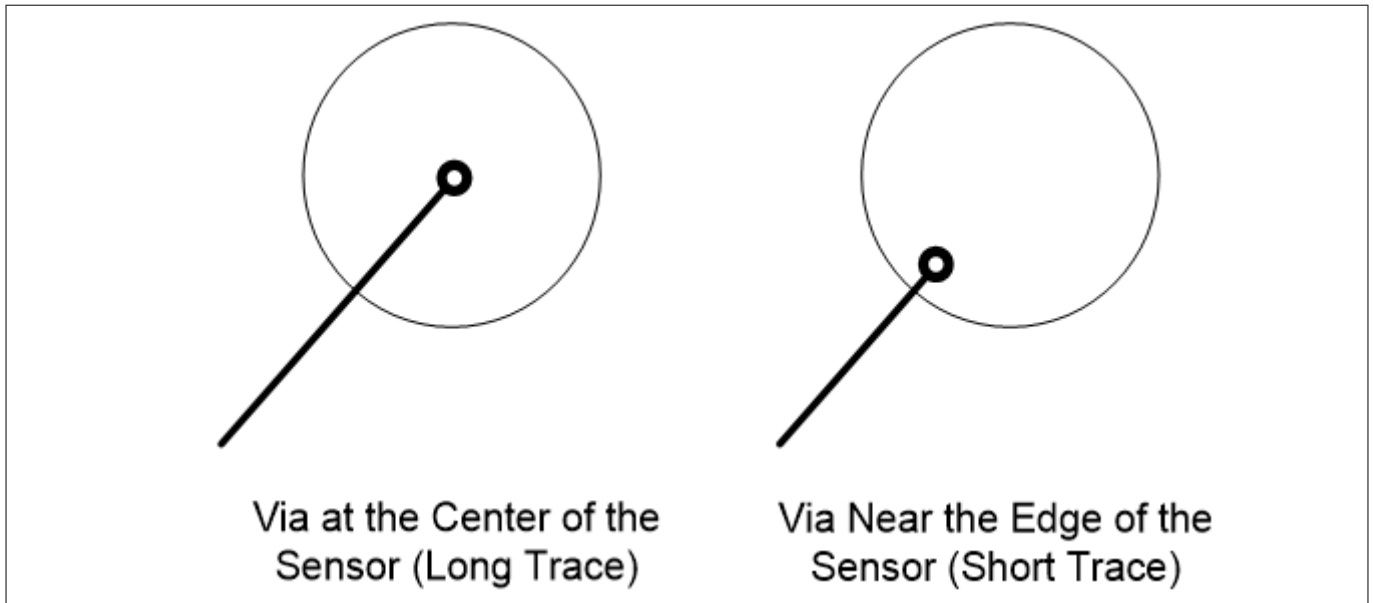

Figure 148 Via placement on the sensor pad

7.4.10 Ground plane

When designing the ground plane, follow these guidelines:

- Ground surrounding the sensors should be in a hatch pattern. If you are using ground or driven-shield planes in both top and bottom layers of the PCB, you should use a 25 percent hatching on the top layer (7-mil line, 45-mil spacing), and 17 percent on the bottom layer (7 mil line, 70 mil spacing)
- For the other parts of the board not related to CAPSENSE™, solid ground should be present as much as possible
- The ground planes on different layers should be stitched together as much as possible, depending on the PCB manufacturing costs. Higher amount of stitching results in lower ground inductance, and brings the chip ground closer to the supply ground. This is important especially when there is high current sinking through the ground, such as when the radio is operational
- Every ground plane used for CAPSENSE™ should be star-connected to a central point, and this central point should be the sole return path to the supply ground. Specifically:
 - The hatch ground for all sensors must terminate at the central point
 - The ground plane for C_{MOD} , C_{INTX} must terminate at the central point
 - The ground plane for C_{SH_TANK} must terminate at the central point

Figure 149 explains the star connection. The central point for different families is mentioned in Table 34.

7 Design considerations

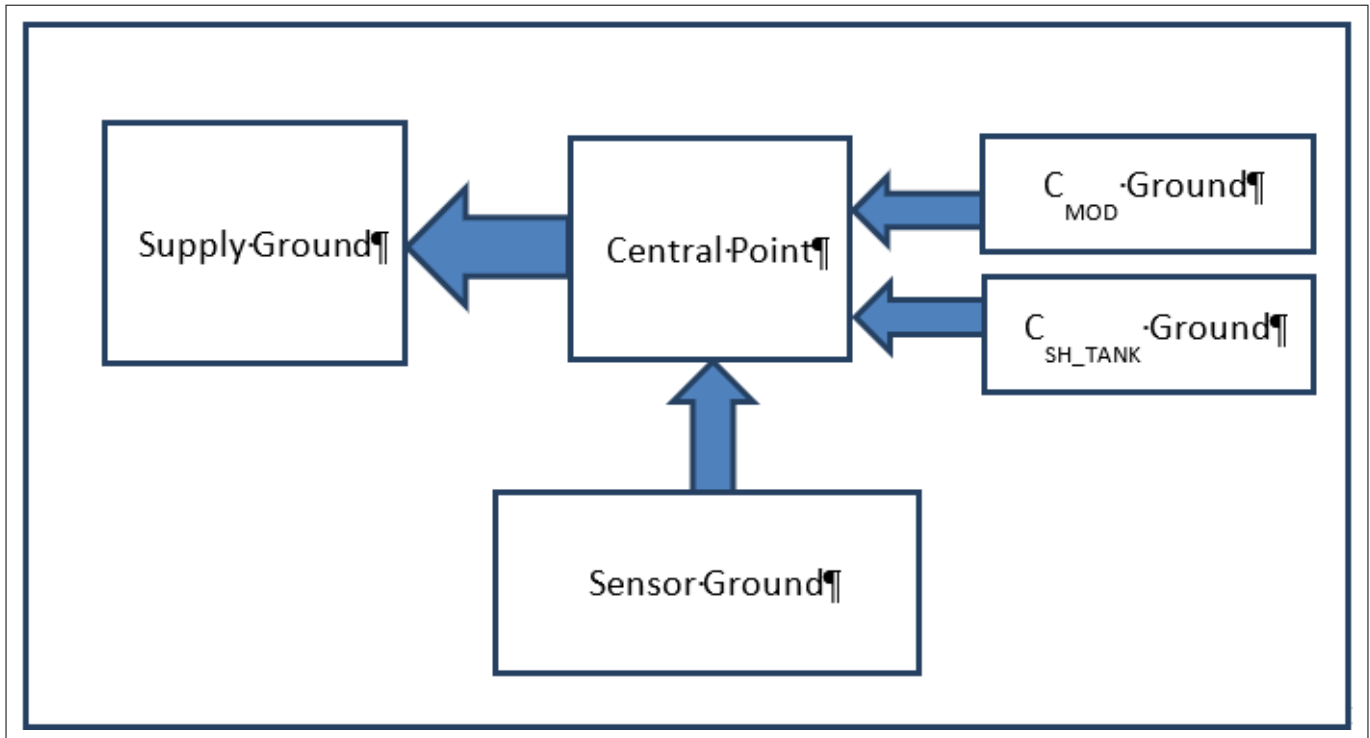

Figure 149 Star connection for Ground

Table 34 Central point for star connection

Family	Central point
PSoC™ 4000	VSS pin
PSoC™ 4100/4100M	VSS pin
PSoC™ 4200/4200M/4200L/PSoC™ 4-S/PSoC™ 4100PS	VSS pin
PSoC™ 4100-BL	E-pad
PSoC™ 4200-BL	E-pad

- All the ground planes for CAPSENSE™ should have an inductance of less than 0.2 nH from the central point. To achieve this, place the C_{MOD}, C_{INTX}, and C_{SH_TANK} capacitor pads close to the chip, and keep their ground planes thick enough

7.4.10.1 Using packages without E-pad

When not using the E-pad, the VSS pin should be the central point and the sole return path to the supply ground. High-level layout diagrams of the top and bottom layers of a board when using a chip without the E-pad are shown in Figure 150 and Figure 151.

7 Design considerations

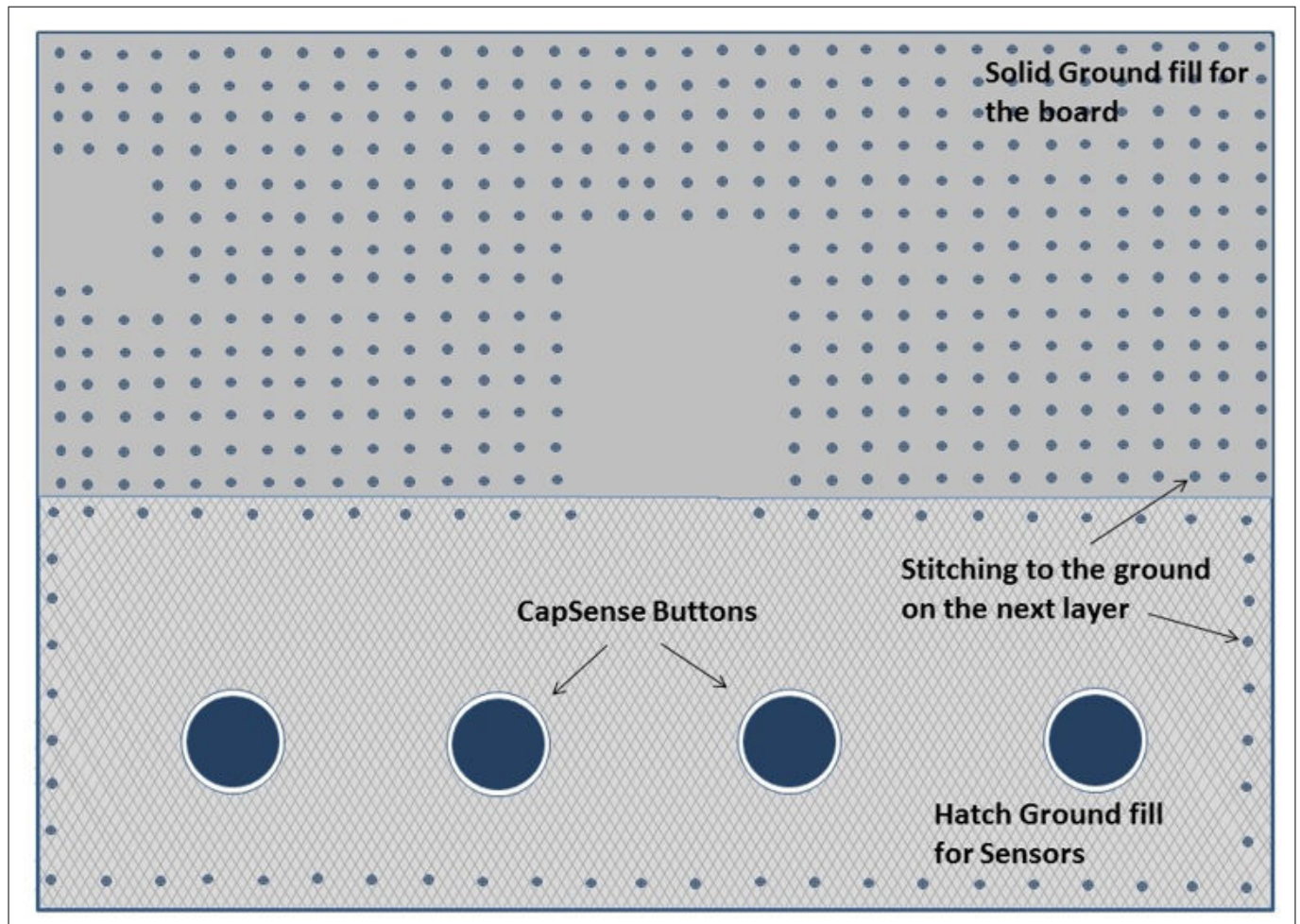

Figure 150 PCB top layer layout using a chip without E-pad

7 Design considerations

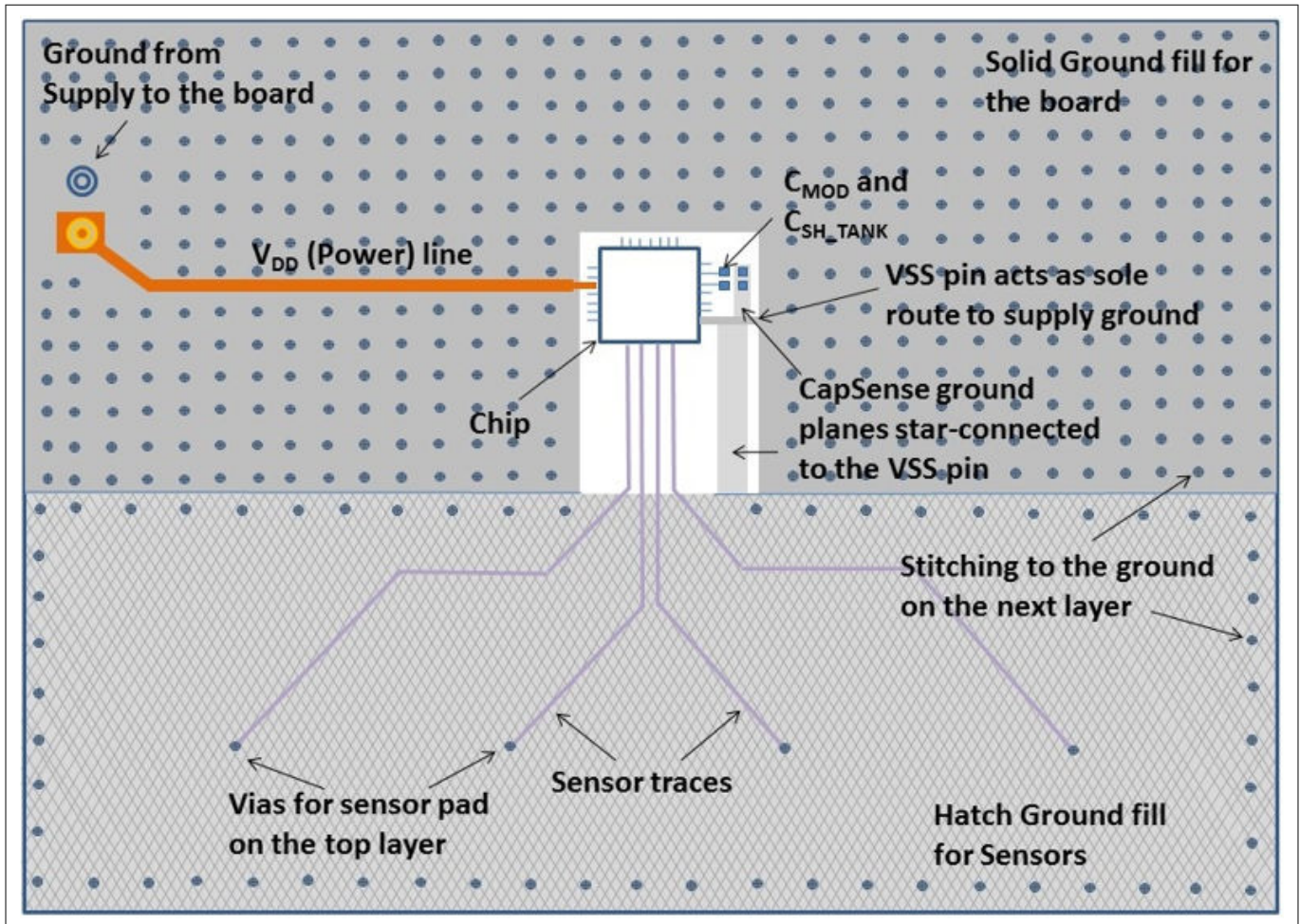

Figure 151 PCB bottom layer layout using a chip without E-pad

7.4.10.2 Using packages with E-pad

If you are using packages with E-pad, the following guidelines must be followed:

- The E-pad must be the central point and the sole return path to the supply ground
- The E-pad must have vias underneath to connect to the next layers for additional grounding. Generally unfilled vias are used in a design for cost purposes, but silver-epoxy filled vias are recommended for the best performance as they result in the lowest inductance in the ground path

7.4.10.3 Using PSoC™ 4 Bluetooth® LE devices

In the case of PSoC™ 4 Bluetooth® LE devices in the QFN package (with E-pad):

- The general guidelines of ground plane (discussed above) apply
- The E-pad usage guidelines of [Using packages with E-pad](#) apply
- The VSSA pin should be connected to the E-pad below the chip itself
- The vias underneath the E-pad are recommended to be 5x5 vias of 10-mil size

High-level layout diagrams of the top and bottom layers of a board when using PSoC™ 4 Bluetooth® LE chips are shown in [Figure 152](#) and [Figure 153](#).

7 Design considerations

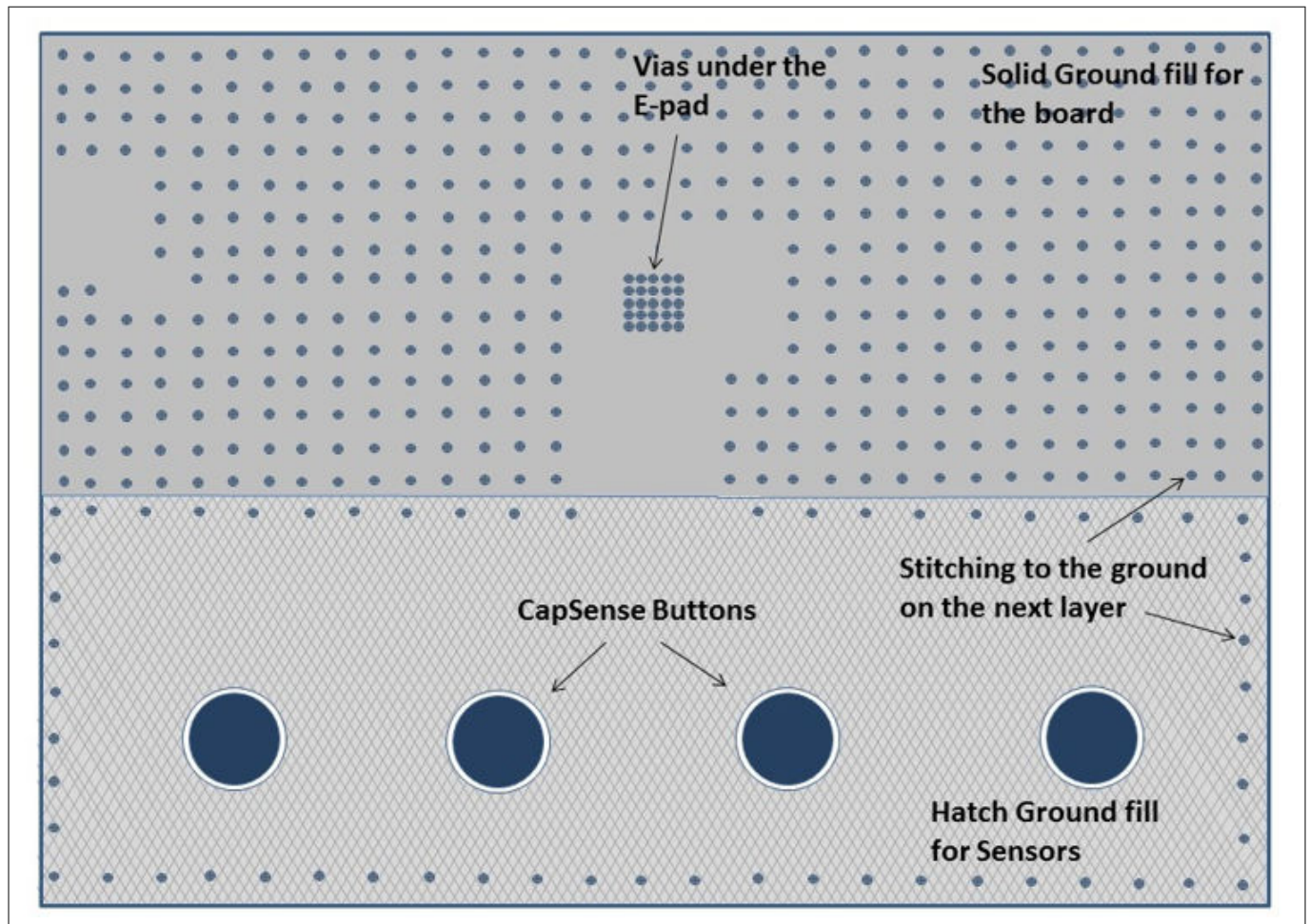

Figure 152 PCB top layer layout with PSoC™ 4Bluetooth® LE (with E-pad)

7 Design considerations

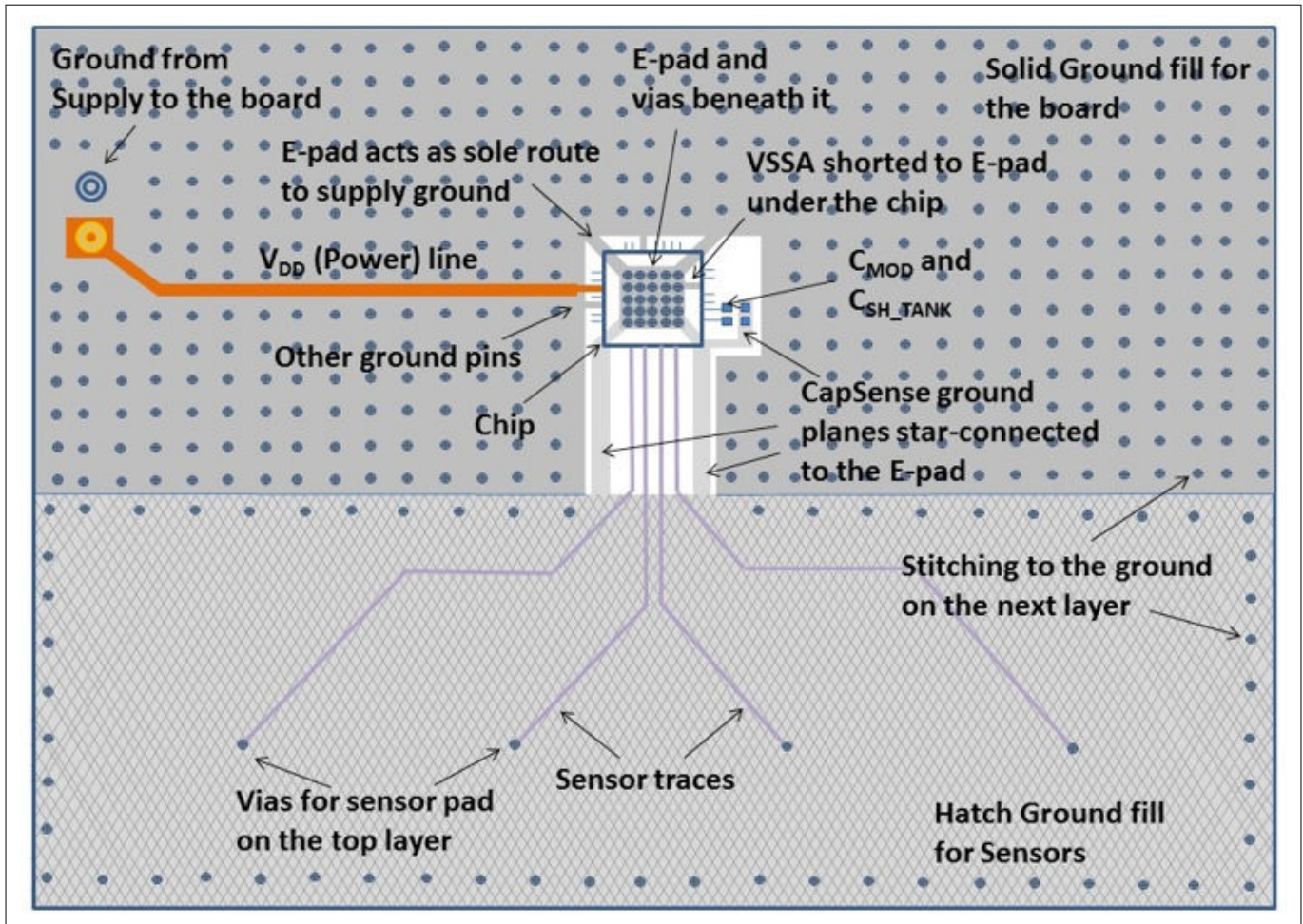

Figure 153 PCB bottom layer layout with PSoC™ 4 Bluetooth® LE (with E-pad)

7.4.11 Power supply layout recommendations

CAPSENSE™ is a high-sensitivity analog system. Therefore, a poor PCB layout introduces noise in high-sensitivity sensor configurations such as proximity sensors and buttons with thick overlays (>1 mm). To achieve low noise in a high-sensitivity CAPSENSE™ design, the PCB layout should have decoupling capacitors on the power lines, as listed in Table 35.

Table 35 Decoupling capacitors on power lines

Power line	Decoupling capacitors	Corresponding ground terminal	Applicable device family
VDD	0.1 µF and 1 µF	VSS	PSoC™ 4000
VDDIO	0.1 µF and 1 µF	VSS	PSoC™ 4000, PSoC™ 6 MCU
VDDD	0.1 µF and 1 µF	VSS	PSoC™ 4100, PSoC™ 4200, PSoC™ 6 MCU
	0.1 µF and 1 µF	VSSD	PSoC™ 4100-BL, PSoC™ 4200-BL, PSoC™ 4200L, PSoC™ S-series, PSoC™ 4100S Plus, PSoC™ 4100S Max
	See device datasheet	VSSD	PSoC™ 4000T

(table continues...)

7 Design considerations

Table 35 (continued) Decoupling capacitors on power lines

Power line	Decoupling capacitors	Corresponding ground terminal	Applicable device family
VDDA ¹⁾	0.1 µF and 1 µF (Battery powered supply)	VSSA	PSoC™ 4100, PSoC™ 4200, PSoC™ 4100-BL, PSoC™ 4200-BL, PSoC™ 4200L, PSoC™ 4S-Series, PSoC™ 4100S Plus, PSoC™ 4100PS, PSoC™ 6 MCU
	0.1 µF and 10 µF (Mains Powered supply)	VSSA	PSoC™ 4S-series, PSoC™ 4100S Plus, PSoC™ 4100PS
VDDR	0.1 µF and 1 µF	VSSD	PSoC™ 4100-BL, PSoC™ 4200-BL, PSoC™ 6 MCU with Bluetooth® LE Connectivity
VCCD	See device datasheet	VSS (PSoC™ 4000) or VSSD (all others)	All device families

1) The V_{DDA} pin on PSoC™ 4 S-Series, PSoC™ 4100S Plus, and PSoC™ 4100PS family requires different values of bulk capacitor depending on the power supply source. If the device is battery powered, it is recommended to use 0.1 µF and 1 µF capacitors in parallel and if the device is mains powered, it is recommended to use 0.1 µF and 10 µF in parallel. This is to improve the power supply rejection ratio of reference generator (REFGEN) used in the CAPSENSE™ block.

The decoupling capacitors and C_{MOD} capacitor must be placed as close to the chip as possible to keep ground impedance and supply trace length as low as possible.

For further details on bypass capacitors, see the Power section in the [Device datasheet](#).

7.4.12 Layout guidelines for liquid tolerance

As explained in the [Liquid tolerance](#) section, by implementing a shield electrode and a guard sensor, a liquid-tolerant™ system can be implemented. If there are multiple CSD blocks in the device, each CSD block should have a dedicated shield electrode. This section shows how to implement a shield electrode and a guard sensor.

7.4.12.1 Layout guidelines for shield electrode

The area of the shield electrode depends on the size of the liquid droplet and the area available on the board for implementing the shield electrode. The shield electrode should surround the sensor pads and traces, and spread no further than 1 cm from these features. Spreading the shield electrode beyond 1 cm has negligible effect on system performance.

Also, having a large shield electrode may increase radiated emissions. If the board area is very large, the area outside the 1-cm shield electrode should be left empty, as [Figure 154](#) shows. The board design should focus on reducing the coupling capacitance between the liquid droplet and ground. Thus, for improved liquid tolerance, there should not be any hatch fill or a trace connected to ground in the top and bottom layers of the PCB.

When there is a grounded hatch fill or a trace then, when a liquid droplet falls on the touch surface, it may cause sensor false triggers. Even if there is a shield electrode between the sensor and ground, the effect of the shield electrode will be totally masked out and sensors may false trigger.

In some applications, there may not be sufficient area available on the PCB for shield electrode implementation. In such cases, the shield electrode can spread less than 1 cm; the minimum area for shield electrode can be the area remaining on the board after implementing the sensor.

In some applications, the capacitance of the shield electrode will be very high; you can reduce it with the following techniques:

7 Design considerations

- Using multiple shield electrode instead of single shield electrode: If there is a single hatch pattern with a higher C_p , split the hatch pattern into multiple hatch patterns and drive it with the shield signal to decrease the shield C_p . This will also allow the use of a higher range of sense clock frequencies for the sensors which will improve the sensitivity of the CAPSENSE™ system. In a complex layout design, this approach will make trace routing simple
- Connecting multiple shield pins to the same electrode: If splitting the shield electrode in the layout is not feasible, connect multiple shield pins to the same electrode. This will make all the series resistance of the sensor pins in parallel and reduce the effective time constant of the shield electrode, which will allow using a higher range of sense clock frequencies for sensors, which will improve the sensitivity of the CAPSENSE™ system

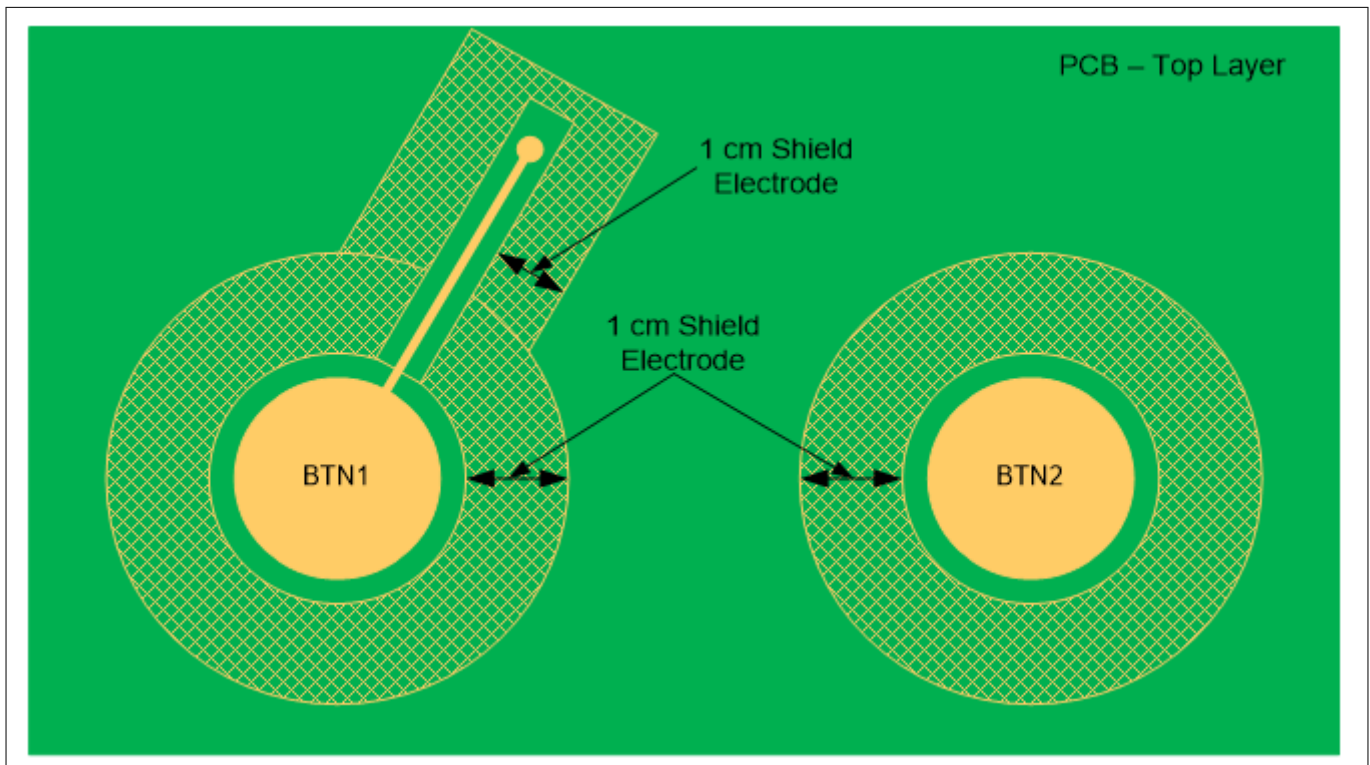

Figure 154 Shield electrode placement when sensor trace is routed in top and bottom layer

Follow these guidelines to implement the shield electrode in two-layer and four-layer PCBs:

Two-layer PCB:

- Top layer: Hatch fill with 7 mil trace and 45 mil grid (25 percent fill). Hatch fill should be connected to the driven-shield signal
- Bottom layer: Hatch fill with 7 mil trace and 70 mil grid (17 percent fill). Hatch fill should be connected to the driven-shield signal

Four (or more)-layer PCB:

- Top layer: Hatch fill with 7 mil trace and 45 mil grid (25 percent fill). Hatch fill should be connected to the driven-shield signal
- Layer-2: Hatch fill with 7 mil trace and 70 mil grid (17 percent fill). Hatch fill should be connected to the driven-shield signal
- Layer-3: V_{DD} Plane
- Bottom layer: Hatch fill with 7 mil trace and 70 mil grid (17 percent fill). Hatch fill should be connected to ground

The recommended air gap between the sensor and the shield electrode is 1 mm.

7 Design considerations

7.4.12.2 Layout guidelines for guard sensor

As explained in the [Guard sensor](#) section, the guard sensor is a copper trace that surrounds all sensors, as [Figure 155](#) shows.

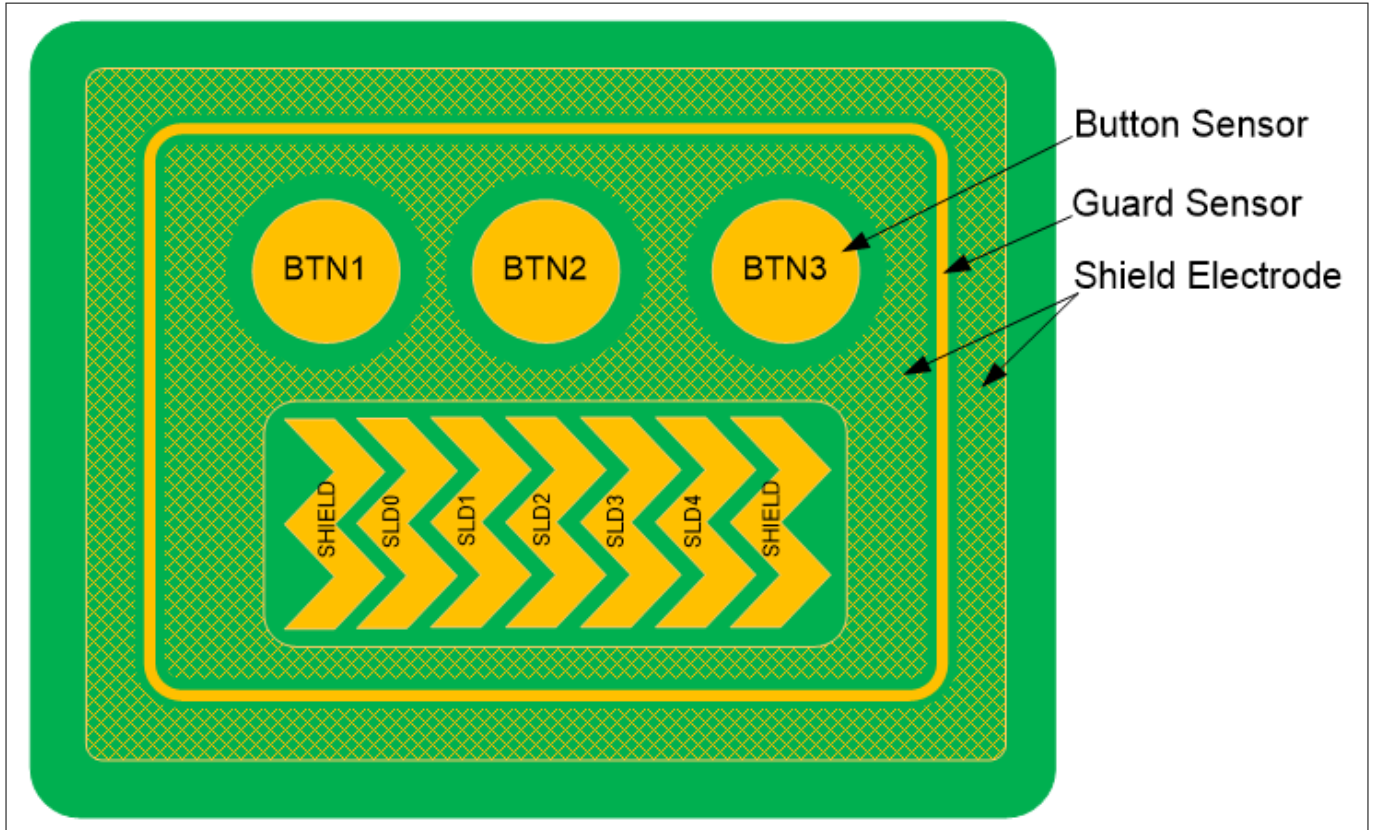

Figure 155 PCB layout with shield electrode and guard sensor

The guard sensor should be triggered only when there is a liquid stream on the touch surface. Ensure that the shield electrode pattern surrounds the guard sensor to prevent it from turning on due to liquid droplets. The guard sensor should be placed such that it meets the following conditions:

- It should be the first sensor to turn on when there is a liquid stream on the touch surface. To accomplish this, the guard sensor is usually placed such that it surrounds all sensors
- It should not be accidentally touched while pressing a button or slider sensor. Otherwise, the button sensors and slider sensor scanning will be disabled and the CAPSENSE™ system will become nonoperational until the guard sensor is turned off. To ensure the guard sensor is not accidentally triggered, place the guard sensor at a distance greater than 1 cm from the sensors

Follow these guidelines to implement the guard sensor:

- The guard sensor should be in the shape of a rectangle with curved edges and should surround all the sensors
- The recommended thickness for a guard sensor is 2 mm
- The recommended clearance between the guard sensor and the shield electrode is 1 mm

If there is no space on the PCB for implementing a guard sensor, the guard sensor functionality can be implemented in the firmware. For example, you can use the ON/OFF status of different sensors to detect a liquid stream depending on the use case data.

The following conditions can be used to detect a liquid stream on the touch surface:

- When there is a liquid stream, more than one button sensor will be active at a time. If your design does not require multi-touch sensing, you can detect this and reject the sensor status of all the button sensors to prevent false triggering

7 Design considerations

- In a slider, if the slider segments which are turned ON are not adjacent segments, you can reset the slider segments status or reject the slider centroid value that is calculated
- A firmware algorithm to detect the false touch due to water drop from the use case data can be made to improve the false touch rejection capability sensors

7.4.12.3 Liquid tolerance with ground ring

In some applications, it is required to have a ground ring (solid trace or a hatch fill) around the periphery of the board for improved ESD performance, as shown in Figure 156. The ground ring is used to redirect the ESD as explained in Redirect. Having a ground ring around the board may result in sensor false triggers when liquid droplets fall in between the sensor and the ground sensor. Therefore, it is recommended not to have any ground in the top layer. If the design must have a ground ring in the top layer, use a ground ring with the minimum thickness (8 mils).

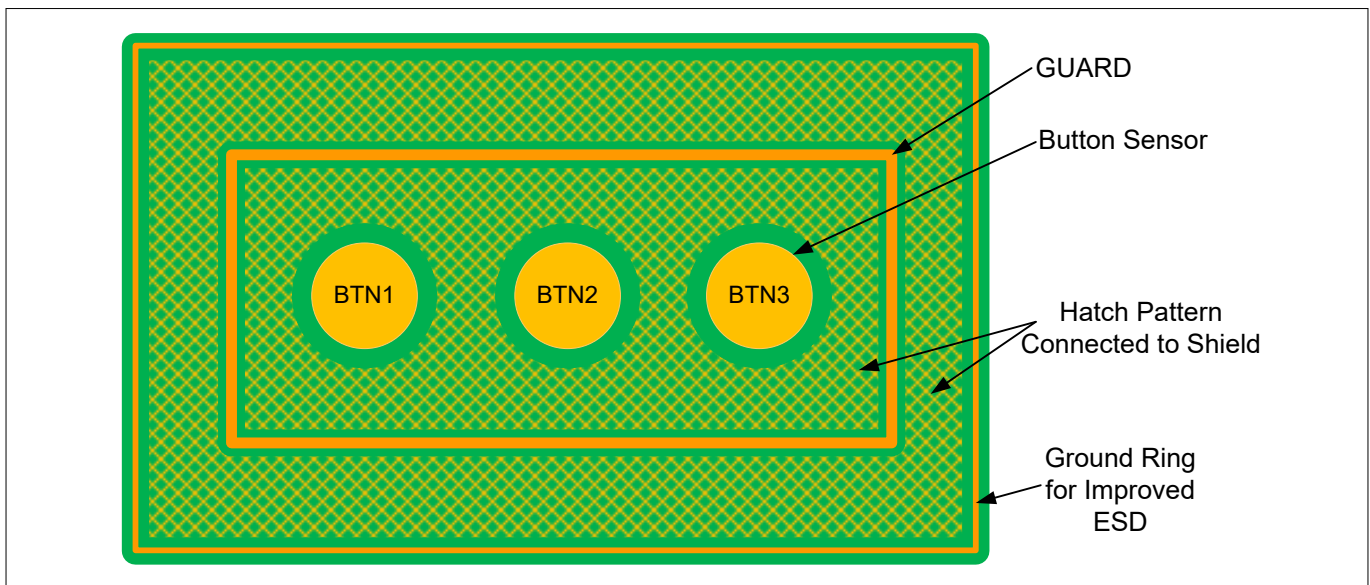

Figure 156 CAPSENSE™ design with ground ring for improved ESD performance

7.4.13 Schematic rule checklist

Table 36 provides the checklist to verify your CAPSENSE™ schematic.

Table 36 Schematic rule checklist

No.	Category	Recommendations/Remarks
1	C _{MOD}	2.2 nF. See Table 37 for pin selection.
2	C _{SH_TANK}	10 nF if shield electrode is used; NA otherwise. See Driven shield signal and shield electrode and CAPSENSE™ CSD shielding for details on shield electrode and use of C _{SH_TANK} respectively. See Table 37 for pin selection.
3	C _{INTA} /C _{INTB}	470 pF. See Table 37 for pin selection.
3	Series resistance on input lines	560 Ω for self-capacitance and 2 kΩ for mutual-capacitance. See Series resistors on CAPSENSE pins for details.

(table continues...)

7 Design considerations

Table 36 (continued) Schematic rule checklist

No.	Category	Recommendations/Remarks
4	Sensor pin selection	If possible, avoid pins that are close to the GPIOs carrying switching/communication signals. Physically separate DC loads such as LEDs and I ² C pins from the CAPSENSE™ pins by a full port wherever possible. See Sensor pin selection section for more details.
5	GPIO source/sink current	Ensure that the total sink current through GPIOs is not greater than 40 mA when the CAPSENSE™ block is scanning the sensors.
6	Series resistance on shield lines	560 Ω recommended on shield lines.

7.4.13.1 External capacitors pin selection

As explained in the [CAPSENSE™ fundamentals](#) section, CAPSENSE™ requires the following external capacitors for reliable operation - C_{MOD} (capacitive sigma-delta (CSD) sensing method), C_{TANK} (only when Shield is implemented), and C_{INTX} (CSX sensing method). Starting from [PSoC™ Creator 3.3 SP2](#), the number of pins that can support C_{MOD} and C_{SH_TANK} is increased to improve design flexibility. [Table 37](#) lists the recommended pins for C_{MOD}, C_{INTX}, and C_{SH_TANK} capacitors for PSoC™ Creator 3.3 SP2 or later versions.

Note: For PSoC™ 4100/PSoC™ 4200, if you select a pin other than P4[2] for C_{MOD}, P4[2] will not be available for any other function. For example, if you try routing C_{MOD} to P2[0] in PSoC™ Creator for a PSoC™ 4200 device, it uses both P2[0] and P4[2].

Table 37 Recommended pins for external capacitors

Device	C _{MOD} (or C _{MOD1} for fifth-generation CAPSENSE™)	C _{SH_TANK} (or C _{MOD2} for fifth-generation CAPSENSE™)
PSoC™ 4000	P0[4]	P0[2]
PSoC™ 4100/PSoC™ 4200	P4[2]	P4[3]
PSoC™ 4200M/PSoC™ 4200L	CSD0: P4[2]	CSD0: P4[3]
	CSD1: P5[0]	CSD1: P5[1]
PSoC™ 4 Bluetooth® LE	P4[0]	P4[1]
PSoC™ 6 MCU	P7[1]	P7[2]
PSoC™ 4S-Series, PSoC™ 4100S Plus	P4[2]	P4[3]
PSoC™ 4100PS	P5[2]	P5[3]
PSoC™ 4100S Max	Channel0: P4[0]	Channel0: P4[1]
	Channel1: P7[0]	Channel1: P7[1]
PSoC™ 4000T	P4[2]	P4[3]

7 Design considerations

Table 38 Supported pins for external capacitors

Device	C _{MOD} (or C _{MOD1} for fifth-generation CAPSENSE™)	C _{SH_TANK} (or C _{MOD2} for fifth-generation CAPSENSE™)	C _{INTA}	C _{INT B}
PSoC™ 4000	Port0[0:7], Port1 [0:7]P2[0]	Port0 [0:7], Port1 [0:7]P2[0]	P0[4]	P0[2]
PSoC™ 4100	Port0 [0:7], Port1 [0:7]Port2 [0:7], Port3 [0:7]P4[2]	Port0 [0:7], Port1 [0:7]Port2 [0:7], Port3 [0:7]P4[3]	Not supported	Not supported
PSoC™ 4200	Port0 [0:7], Port1 [0:7]Port2 [0:7], Port3 [0:7]P4[2]	Port0 [0:7], Port1 [0:7], Port2 [0:7], Port3 [0:7]P4[3]	Port0 [0:7], Port1 [0:7]Port2 [0:7], Port3 [0:7]	Port0 [0:7], Port1 [0:7]Port2 [0:7], Port3 [0:7]
PSoC™ 4200M	CSD0: Port0 [0:7], Port1 [0:7] Port2 [0:7], Port3 [0:7] Port4 [0:6], Port6 [0:5] Port7 [0:1]	CSD0: Port0 [0:7], Port1 [0:7]Port2 [0:7], Port3 [0:7], Port4 [0:6], Port6 [0:5] Port7 [0:1]	CSD0: P4[2]	CSD0: P4[3]
	CSD1: Not supported	CSD1: Not supported	CSD1: Not supported	CSD1: Not supported
PSoC™ 4200L	CSD0: Port0 [0:7], Port1 [0:7] Port2 [0:7], Port3 [0:7] Port4 [0:6], Port6 [0:5] Port7 [0:7], Port10 [0:7], Port11 [0:7]	CSD0: Port0 [0:7], Port1 [0:7] Port2 [0:7], Port3 [0:7] Port4 [0:6], Port6 [0:5] Port7 [0:7], Port10 [0:7] Port11 [0:7]	CSD0: P4[2]	CSD0: P4[3]
	CSD1: Port5 [0:7], Port8 [0:7] Port9 [0:7]	CSD1: Port5 [0:7], Port8 [0:7] Port9 [0:7]	CSD1: P5[0]	CSD1: P5[1]
PSoC™ 4 Bluetooth® LE	Port0 [0:7], Port1 [0:7]Port2 [0:7], Port3 [0:7]Port4 [0:1], Port5 [0:1]Port6 [0:1]	Port0 [0:7], Port1 [0:7]Port2 [0:7], Port3 [0:7]Port4 [0:1], Port5 [0:1]Port6 [0:1]	P4[0]	P4[1]
PSoC™ 6 MCU	P7[1] or P7[2] or P7[7]	P7[1] or P7[2] or P7[7]	P7[1]	P7[2]
PSoC™ 4S-Series, PSoC™ 4100S Plus	P4[2], P4[3], P4[1]	P4[2], P4[3], P4[1]	P4[2]	P4[3]
PSoC™ 4100PS	P5[0], P5[2], P5[3]	P5[0], P5[2], P5[3]	P5[2]	P5[3]
PSoC™ 4100S Max ¹⁾	Channel0: P4[0], P4[2]	Channel0: P4[1], P4[3]	Not applicable	Not applicable
	Channel1: P7[0], P5[1]	Channel1: P7[1], P5[2]		
PSoC™ 4000T	P4[2],	P4[3]	Not applicable	Not applicable

1) Supported pin paring for PSoC™ 4100S Max: C_{MOD1}/C_{MOD2} = P4[0] /P4[1] or P4[2] /P4[3] or P7[0] /P7[1] or P5[1] /P5[2]

7 Design considerations

7.4.13.2 Sensor pin selection

As explained in [CAPSENSE™ fundamentals](#), PSoC™ supports CSD and CSX capacitive sensing methods. Each CSD sensor requires a single sensor pin and CSX sensor will require two sensor pins for Tx and Rx electrode in addition to the required external capacitors for each sensing technique.

The selection of the sensor pins should be in a way such that the CAPSENSE™ sensor traces and communication or other toggling GPIO traces are isolated by proper port/pin assignment. The following are some recommended guidelines:

- Isolate switching signals, such as PWM, I2C communication lines, and LEDs from the sensor and sensor traces. Place them at least 4 mm apart and fill a hatched ground between the CAPSENSE™ traces and the switching signals to avoid crosstalk
- Distribute the placement of DC loads on different ports to reduce the noise in CAPSENSE™. It is recommended to have digital I/Os spread on different ports rather than concentrating in a single port
- While the CAPSENSE™ block is scanning the sensor, limit the total source or sink current through GPIOs to less than 40 mA while the CAPSENSE™ block is scanning the sensor. Sinking a current greater than 40 mA while the CAPSENSE™ sensor is scanning may result in excessive noise in the sensor raw count
- For a PSoC™ 4 device it is recommended to place all the digital DC loads like LEDs, I2C/UART communication pins on the port powered by only VSSD; see the [Device datasheet](#) for determining the ports that are powered by VSSD. Placing DC loads on ports powered by VSSA will shift the VSSA up. Since CAPSENSE™ is powered by VSSA, it will affect its performance
- For PSoC™ 6 family of devices:
 - [Table 39](#) lists the ports that support CAPSENSE™, selecting ports 5, 6, 7, and 8 for CAPSENSE™ ensures lesser noise
 - It is recommended to place all digital switching pins such as LEDs, I²C, UART, SPI, SMIF communication pins on the ports that are powered by a different power supply domain which is not shared with the CAPSENSE™ ports. [Table 40](#) lists the ports, their supply domains, and recommendations for using these ports with CAPSENSE™. For more details, see the Errata section of the [Device datasheet](#). A deviation from these guidelines might cause a noise due to level shift in raw count. For more details, see [Raw counts show a level-shift or increased noise when GPIOs are toggled](#). To isolate the supply domains further, it is better to externally isolate them using ferrite beads as shown in [Figure 158](#)

Table 39 CAPSENSE™ capable ports in PSoC™ 6 devices

Device	CAPSENSE™ capable ports
CY8C62x6, CY8C62x7	P0, P1, P2, P4, P5, P6, P7, P8, P9, P10, P11
CY8C63x6, CY8C63x7	P0, P1, P2, P4, P5, P6, P7, P8, P9, P10, P11
CY8C62x5	P7.0 to P7.7, P8.0 to P8.3, P9.0 to P9.3

Table 40 Recommendations of port usage with CAPSENSE™ for PSoC™ 6 device

Ports	Supply domain	Recommended for CAPSENSE™	Recommendations for GPIOs if used for communication, LEDs, and other high frequency functionality with CAPSENSE™
P0	VBACKUP	No*	Switching frequency < 8 MHz
P1	VDDD	No*	Switching frequency < 1 MHz, SLOW Slew Rate
P2, P3, P4	VDDIO2	No*	Switching frequency < 25 MHz

(table continues...)

7 Design considerations

Table 40 (continued) Recommendations of port usage with CAPSENSE™ for PSoC™ 6 device

Ports	Supply domain	Recommended for CAPSENSE™	Recommendations for GPIOs if used for communication, LEDs, and other high frequency functionality with CAPSENSE™
P5, P6, P7, P8	VDDIO1	Yes	Not recommended
P9, P10	VDDIOA	No*	Switching frequency < 1 MHz, SLOW Slew Rate
P11, P12, P13	VDDIO0	No*	Switching frequency < 80 MHz
P14	VDDUSB	No*	NA

Note: * If you need additional CAPSENSE™ pins and if you must use GPIOs in ports P1, P9, and P10 as Tx electrode for CSX sensor, restrict the Tx clock frequency within 1 MHz and use SLOW slew rate. Figure 157 shows an example on how to select the **Slew Rate** of the GPIO using the Device configurator in the ModusToolbox™ project. Note that using the ports other than the recommended ports for CAPSENSE™ might cause higher noise in raw count.

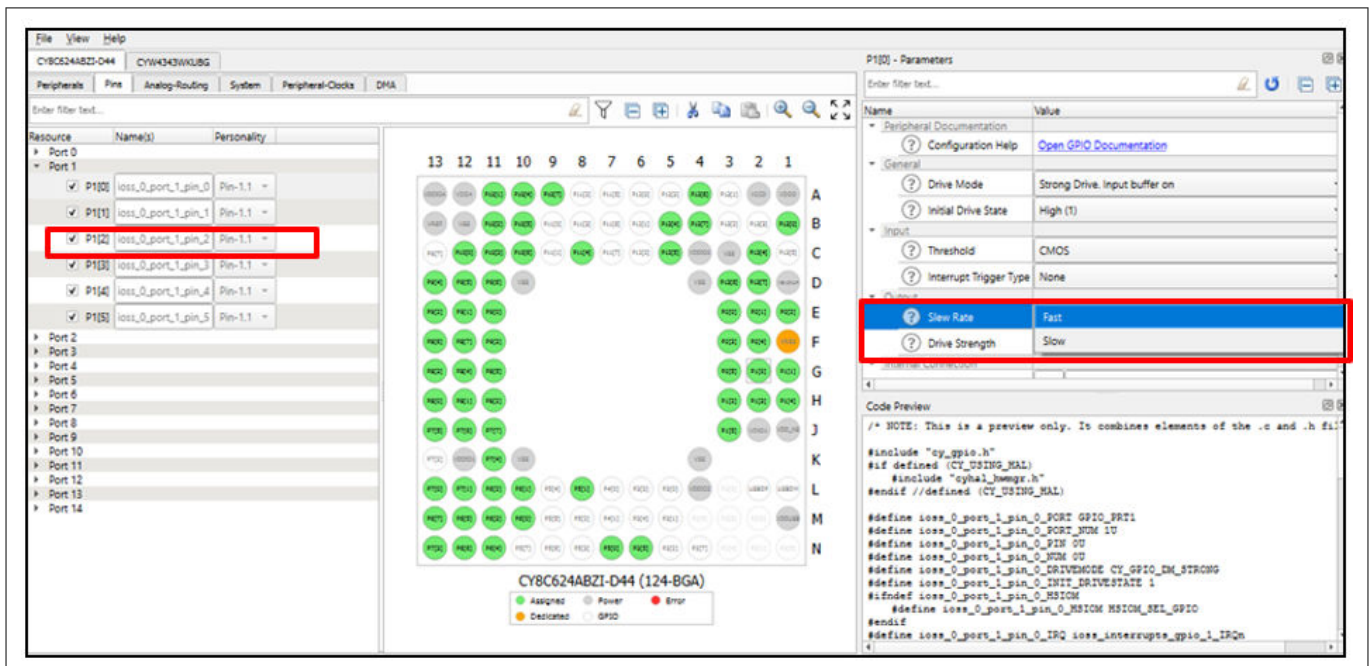

Figure 157 Selecting slew rate for GPIOs

7 Design considerations

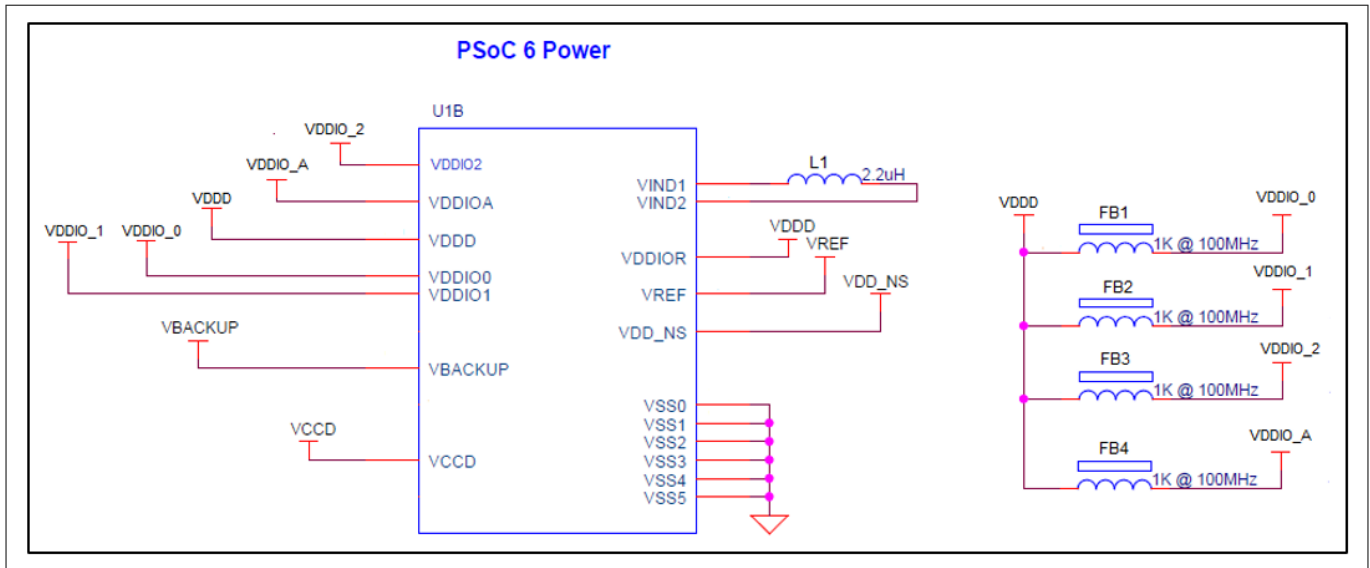

Figure 158 Externally isolated supply domains

7.4.14 Layout rule checklist

Table 41 provides the checklist to help verify your layout design.

Table 41 Layout rule checklist

No.	Category		Minimum value	Maximum value	Recommendations/Remarks
1	Button	Shape	N/A	N/A	Circle or rectangular with curved edges
		Size	5 mm	15 mm	10 mm
		Clearance to ground hatch	0.5 mm	2 mm	Should be equal to overlay thickness
2	Slider	Width of segment	1.5 mm	8 mm	8 mm
		Clearance between segments	0.5 mm	2 mm	0.5 mm
		Height of segment	7 mm	15 mm	12 mm
3	Overlay	Type	N/A	N/A	Material with high relative permittivity (except conductors) Remove any air gap between sensor board and overlay/front panel of the casing.
		Thickness for buttons	N/A	5 mm	
		Thickness for sliders	N/A	5 mm	

(table continues...)

7 Design considerations

Table 41 (continued) Layout rule checklist

No.	Category		Minimum value	Maximum value	Recommendations/Remarks
		Thickness for touchpads	N/A	0.5 mm	
4	Sensor traces	Width	N/A	7 mil	Use the minimum width possible with the PCB technology that you use.
		Length	N/A	300 mm for a standard (FR4) PCB 50 mm for flex PCB	Keep as low as possible.
		Clearance to ground and other traces	0.25 mm	N/A	Use maximum clearance while keeping the trace length as low as possible.
		Routing	N/A	N/A	Route on the opposite side of the sensor layer. Isolate from other traces. If any non-CAPSENSE™ trace crosses the CAPSENSE™ trace, ensure that intersection is orthogonal. Do not use sharp turns.
5	Via	Number of vias	1	2	At least one via is required to route the traces on the opposite side of the sensor layer.
		Hole size	N/A	N/A	10 mil
6	Ground	Hatch fill percentage	N/A	N/A	Use hatch ground to reduce parasitic capacitance. Typical hatching: 25% on the top layer (7 mil line, 45 mil spacing) 17% on the bottom layer (7 mil line, 70 mil spacing)
7	Series resistor	Placement	N/A	N/A	Place the resistor within 10 mm of the PSoC™ pin. See Figure 159 for an example placement of series resistance on board.
8	Shield electrode	Spread	N/A	1 cm	If you have PCB space, use 1-cm spread.
9	Guard sensor (for water tolerance)	Shape	N/A	N/A	Rectangle with curved edges

(table continues...)

7 Design considerations

Table 41 (continued) Layout rule checklist

No.	Category		Minimum value	Maximum value	Recommendations/Remarks
		Thickness	N/A	N/A	Recommended thickness of guard trace is 2 mm and distance of guard trace to shield electrode is 1 mm.
10	Ground Ring(for ESD protection)	Shape	N/A	N/A	Around the board periphery with curved edges. Can be a solid trace or a hatch fill.
		Thickness	N/A	N/A	Not recommended in top layer as it can cause sensor false triggers with liquid droplets. If design must have a Ground Ring in the top layer, use a minimum thickness ring of 8 mils.
11	C_{MOD}	Placement	N/A	N/A	Place close to the PSoC™ pin. See Figure 159 for an example placement of C_{MOD} on PCB.
12	C_{SH_TANK}	Placement	N/A	N/A	Place close to the PSoC™ pin. See Figure 159 for an example placement of C_{SH_TANK} on board.
13	C_{INTA}	Placement	N/A	N/A	Place close to the PSoC™ pin. See Figure 159 for an example placement of C_{INTA} on the PCB.
14	C_{INTB}	Placement	N/A	N/A	Place close to the PSoC™ pin. See Figure 159 for an example placement of C_{INTA} on the PCB.

7 Design considerations

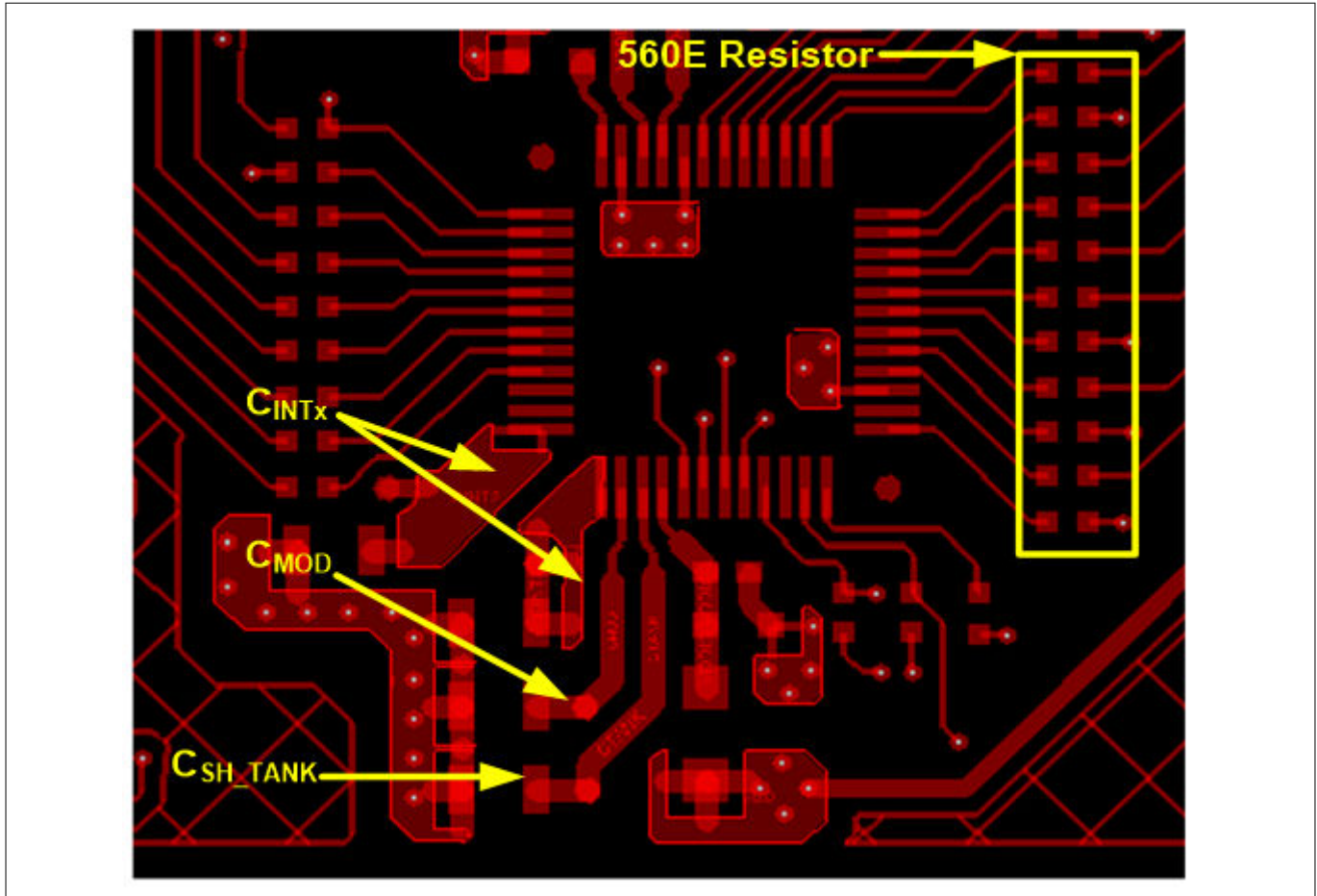

Figure 159 Example placement for C_{MOD} , C_{INTx} , C_{SH_TANK} , and series resistance on input lines in the PSoC™ 4200M device

7.5 Noise in CAPSENSE™ system

7.5.1 Finger injected noise

If the power supply design of the system is poor, the power and ground supplies of a device fluctuates in voltage relative to the finger ground (earth ground) in a common mode fashion. This type of noise is called common mode noise. Figure 160 illustrates the common mode noise, where both the 5 V and the 0 V output leads of the power supply remain 5 V from each other, but they move up and down together, in a “common mode” manner.

This is not a problem, until a finger touch occurs on the button. A finger touch on the button introduces a (capacitive) path to the same earth ground and it will create a path for charge flow, which is equivalent to a noise signal injected exactly at the finger touch location. This injected noise caused by the common mode noise in power supply is called finger injected noise. It is observed only during the finger touch on the button in AC powered application and it doesn’t occur in battery powered application.

7 Design considerations

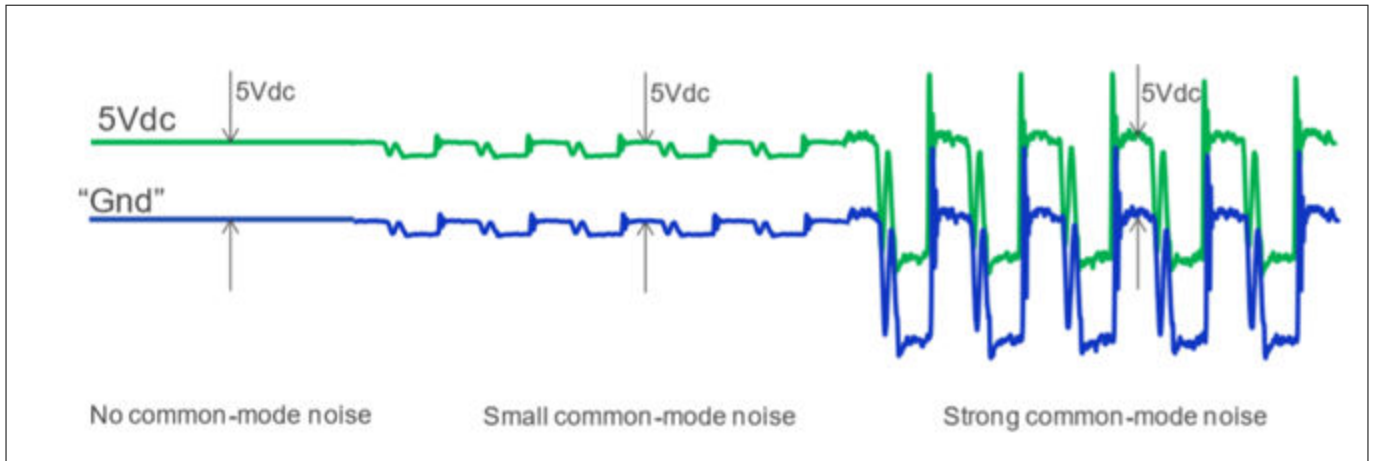

Figure 160 Common mode noise in the power supply

Note: When the complete system powered by AC supply is held in hand of the user, the entire system will be grounded to earth sufficiently and no significant “common-mode” noise would flow through the touching finger to earth. However, if the system is connected to the power supply and placed on a desk, a touch on the button, can introduce a problematic discharge path to ground.

7.5.1.1 Recommendations to reduce the finger injected noise

The finger injected noise could be reduced by properly following the layout and schematics guidelines described in this section. The general recommendations to reduce the finger injected noise is explained below.

1. Fill the PCB board around the button with hatched pattern and connected it to device ground. Follow the recommendations as mentioned in the section [Ground plane](#).

[Figure 161](#) shows the impact of ground on the finger injected noise for mutual capacitance button and it is also true for CSD sensing technique. In the left figure, the system doesn’t have the hatched ground around the button and most of the injected noise through the finger pass to the Rx pin of the device through the Capacitance formed between the finger and Rx electrode. In the right figure, the system has the hatched ground around the button and thus the finger injected noise is having an alternate path to flow which results in the reduction of the noise reaching to the device Rx pin.

7 Design considerations

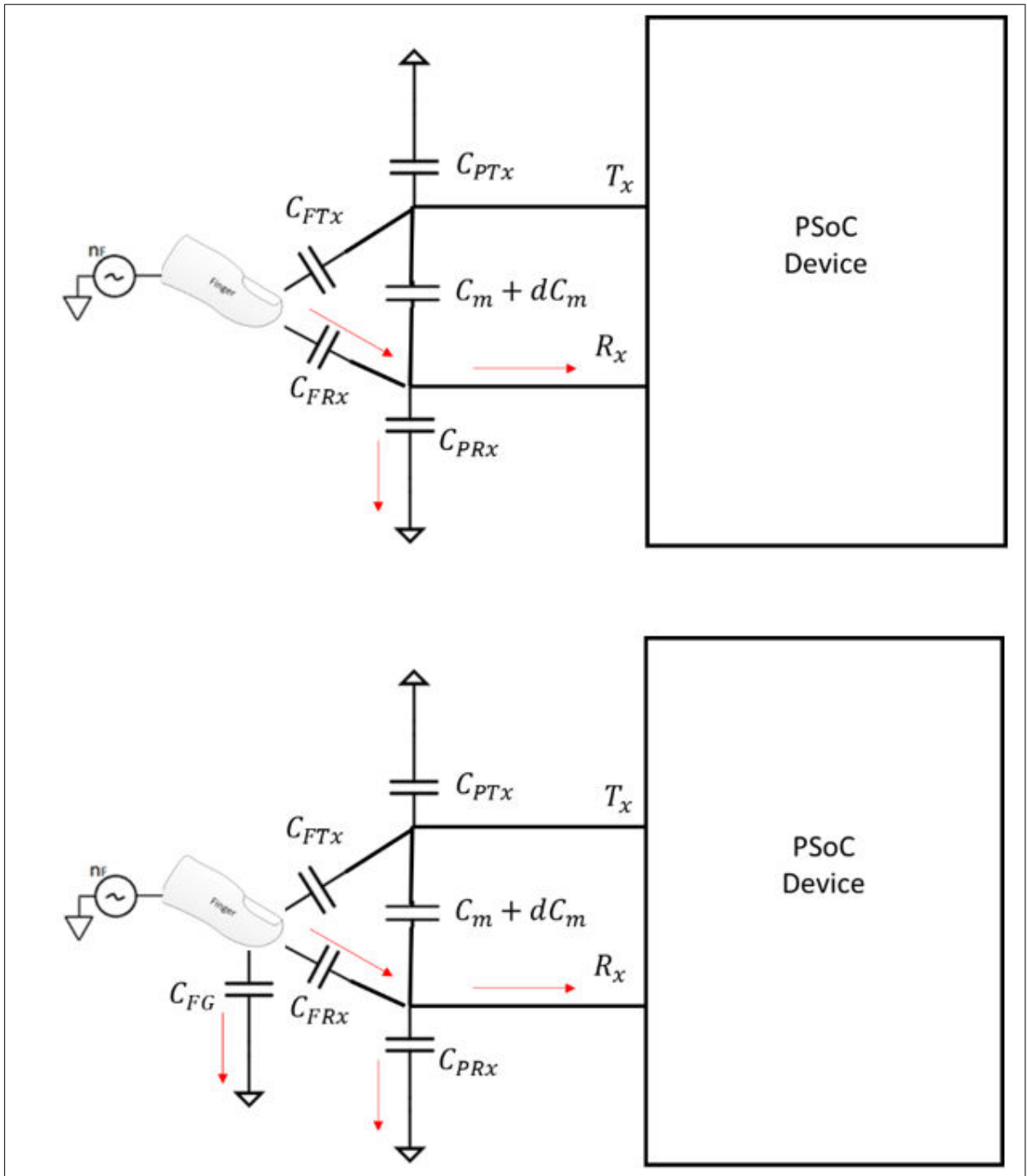

Figure 161 Effect of ground on finger injected noise

2. Better power supply design of the system could easily eliminate the common mode noise, which will in turn reduce the finger injected noise
3. Use software technique that are available in the CAPSENSE™ component to combat the finger injected noise such as selecting optimal sensing clock frequency and Multi frequency scanning, and so on
4. Increase the overlay thickness will reduce the finger injected noise as it will decrease the capacitance formed between the finger and Rx electrode

7.5.2 VDDA noise

The noise in the system due to unwanted voltage ripples in the VDD supply is called VDDA noise.

7 Design considerations

7.5.2.1 Recommendations to reduce the VDDA noise

The VDDA noise could be reduced by properly following the layout and schematics guidelines in this chapter. The general recommendations to reduce the VDDA noise as follows:

1. Use clean power supply and have VDD ripples below the limits mentioned in the device datasheet
2. Use filters or LDO regulator in the VDD power lines
3. Use decoupling capacitors on the power supply pins to reduce the conducted noise from the power supply
4. To reduce high-frequency noise, place a ferrite bead around power supply or communication lines
5. Selecting the proper supply configuration as mentioned in the Power section in the [Device datasheet](#) and using the internal regulator to the device might help in reducing the VDDA noise

7.5.3 External noise

Any noise that is injected into to the system through the routing trace lines like ESD, EMI, conducted noise are coming into the category of external noise. The recommended guidelines for reducing the impact of the external noise are discussed in this section.

7.5.3.1 ESD protection

The nonconductive overlay material used in CAPSENSE™ provides inherent protection against ESD. [Table 42](#) lists the thickness of various overlay materials, required to protect the CAPSENSE™ sensors from a 12 kV discharge (according to the IEC 61000 4 2 specification).

Table 42 Overlay thickness for ESD protection

Material	Breakdown voltage (V/mm)	Minimum overlay thickness for protection against 12 kV ESD (mm)
Air	1200 – 2800	10
Wood – dry	3900	3
Glass – common	7900	1.5
Glass – Borosilicate (Pyrex®)	13,000	0.9
PMMA Plastic (Plexiglas®)	13,000	0.9
ABS	16,000	0.8
Polycarbonate (Lexan®)	16,000	0.8
Formica	18,000	0.7
FR-4	28,000	0.4
PET Film (Mylar®)	280,000	0.04
Polyimide Film (Kapton®)	290,000	0.04

If the overlay material does not provide sufficient protection (for example, ESD from other directions), you can apply other ESD counter-measures, in the following order: [Prevent](#), [Redirect](#), and [ESD protection devices](#).

7.5.3.1.1 Preventing ESD discharge

Preventing the ESD discharge from reaching the PSoC™ is the best countermeasure you can take. Make sure that all paths to PSoC™ have a breakdown voltage greater than the maximum ESD voltage possible at the surface of the equipment. You should also maintain an appropriate distance between the PSoC™ and possible ESD

7 Design considerations

sources. In the example illustrated in Figure 162, if L1 and L2 are greater than 10 mm, the system can withstand a 12 kV ESD.

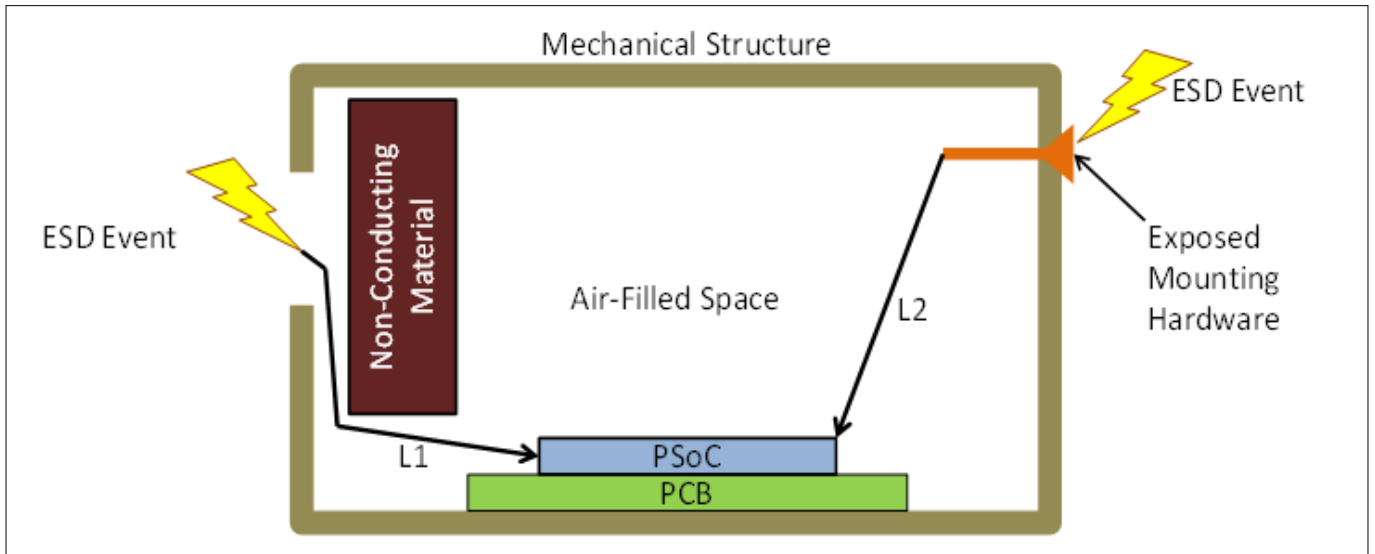

Figure 162 ESD paths

If it is not possible to maintain adequate distance, place a protective layer of nonconductive material with a high breakdown voltage between the possible ESD source and PSoC™. One layer of 5 mil thick Kapton® tape can withstand 18 kV. See Table 42 for other material dielectric strengths.

7.5.3.1.2 Redirect

If your product is densely packed, preventing the discharge event may not be possible. In such cases, you can protect the PSoC™ from ESD by redirecting the ESD. A standard practice is to place a ground ring on the perimeter of the circuit board, as Figure 163 shows. The ground ring should connect to the chassis ground. Using a hatched ground plane around the button or slider sensor can also redirect the ESD event away from the sensor and PSoC™.

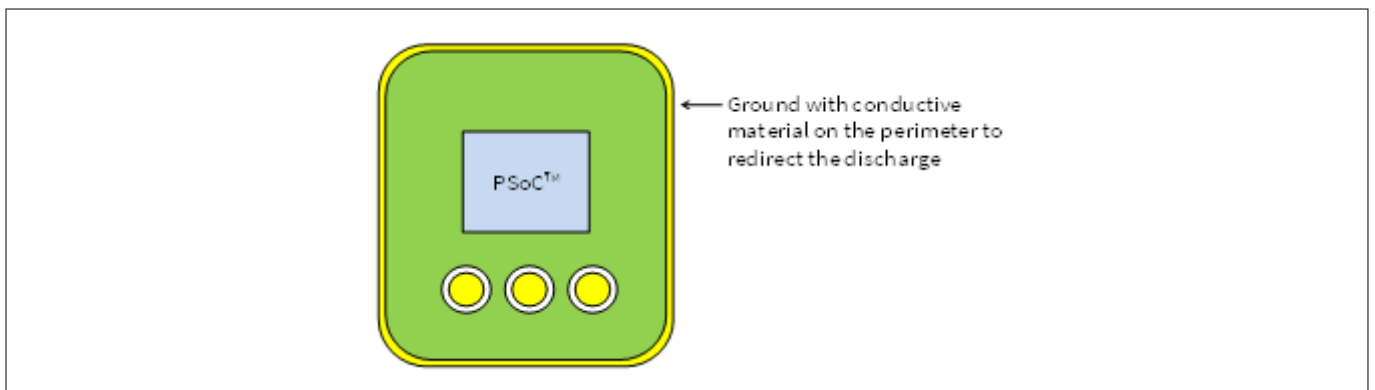

Figure 163 Ground ring

7.5.3.1.3 ESD protection devices

You can use ESD protection devices on vulnerable traces. Select ESD protection devices with a low input capacitance to avoid reduction in CAPSENSE™ sensitivity. Table 43 lists the recommended ESD protection devices.

7 Design considerations

Table 43 ESD protection devices

ESD protection device		Input capacitance	Leakage current	Contact maximum ESD limit	Air discharge maximum ESD limit
Manufacturer	Part number				
Littelfuse	SP723	5 pF	2 nA	8 kV	15 kV
Vishay	VBUS05L1-DD1	0.3 pF	0.1 µA	±15 kV	±16 kV
NXP	NUP1301	0.75 pF	30 nA	8 kV	15 kV

7.5.3.2 Electromagnetic compatibility (EMC) considerations

EMC is related to the generation, transmission, and reception of electromagnetic energy that can affect the working of an electronic system. Electronic devices are required to comply with specific limits for emitted energy and susceptibility to external events. Several regulatory bodies worldwide set regional regulations to help ensure that electronic devices do not interfere with each other.

CMOS analog and digital circuits have very high input impedance. As a result, they are sensitive to external electric fields. Therefore, you should take adequate precautions to ensure their proper operation in the presence of radiated and conducted noise.

Computing devices are regulated in the US by the FCC under Part 15, Sub-Part B for unintentional radiators. The standards for Europe and the rest of the world are adapted from CENELEC. These are covered under CISPR standards (dual-labeled as ENxxxx standards) for emissions, and under IEC standards (also dual labeled as ENxxxx standards) for immunity and safety concerns.

The general emission specification is EN55022 for computing devices. This standard cover both radiated and conducted emissions. Medical devices in the US are not regulated by the FCC, but rather are regulated by FDA rules, which include requirements of EN55011, the European norm for medical devices. Devices that include motor controls are covered under EN55014 and lighting devices are covered under EN55015.

These specifications have essentially similar performance limitations for radiated and conducted emissions. Radiated and conducted immunity (susceptibility) performance requirements are specified by several sections of EN61000-4. Line voltage transients, ESD and some safety issues are also covered in this standard.

7.5.3.2.1 Radiated interference and emissions

While PSoC™ 4 and PSoC™ 6 Bluetooth® LE offer a robust CAPSENSE™ performance, radiated electrical energy can influence system measurements and potentially influence the operation of the CAPSENSE™ processor core. Interference enters the CAPSENSE™ device at the PCB level through sensor traces and through other digital and analog inputs. CAPSENSE™ devices can also contribute to electromagnetic compatibility (EMC) issues in the form of radiated emissions.

Use the following techniques to minimize the radiated interference and emissions.

Hardware considerations

Ground Plane

In general, proper ground plane on the PCB reduces both RF emissions and interference. However, solid grounds near CAPSENSE™ sensors or traces connecting these sensors to PSoC™ pins increase the parasitic capacitance of the sensors. It is thus recommended to use hatched ground planes surrounding the sensor and on the bottom layer of the PCBs, below the sensors, as explained in the [Ground plane](#) section in [PCB layout guidelines](#). Solid ground may be used below the device and other circuitry on the PCB which is farther from

7 Design considerations

CAPSENSE™ sensors and traces. A solid ground flood is not recommended within 1 cm of CAPSENSE™ sensors or traces.

Series resistors on CAPSENSE pins

Every CAPSENSE™ controller pin has some parasitic capacitance (C_p) associated with it. As Figure 164 shows, adding an external resistor forms a low-pass RC filter that attenuates the RF noise amplitude coupled to the pin. This resistance also forms a low-pass filter with the parasitic capacitance of the CAPSENSE™ sensor that significantly reduces the RF emissions.

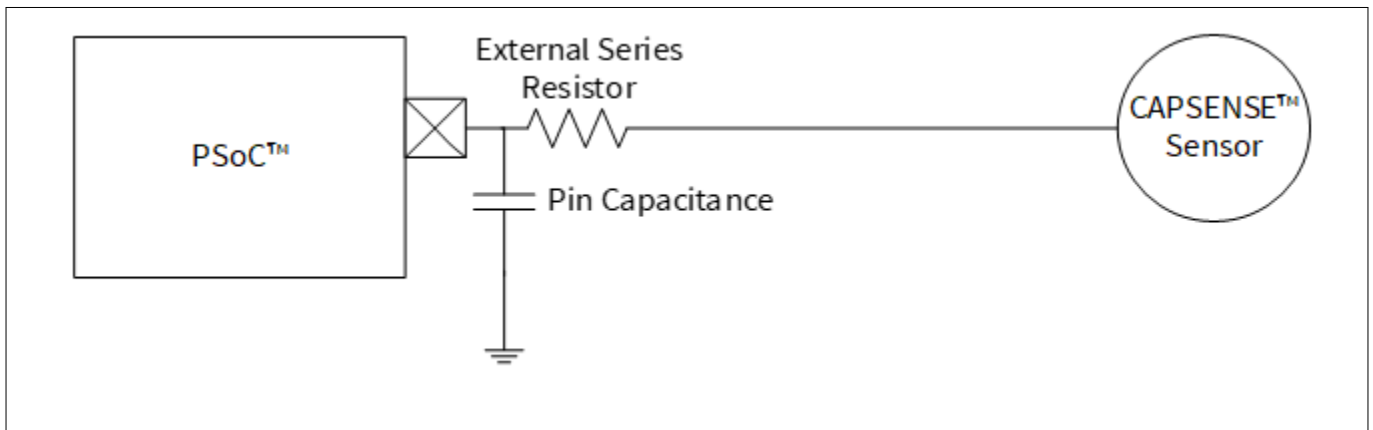

Figure 164 RC filter

Series resistors should be placed close to the device pins so that the radiated noise picked by the traces gets filtered at the input of the device. Thus, it is recommended to place series resistors within 10 mm of the pins. For CAPSENSE™ designs using copper on PCBs, the recommended series resistance for CAPSENSE™ input lines is 560 Ω. Adding resistance increases the time constant of the switched-capacitor circuit that converts C_p into an equivalent resistor; see [GPIO cell capacitance to current converter](#). If the series resistance value is larger than 560 Ω, the slower time constant of the switching circuit suppresses the emissions and interference, but limits the amount of charge that can transfer. This lowers the signal level, which in turn lowers the SNR. Smaller values are better in terms of SNR, but are less effective at blocking RF.

Series resistors on digital communication lines

Communication lines, such as I²C and SPI, also benefit from series resistance; 330 Ω is the recommended value for series resistance on communication lines. Communication lines have long traces that act as antennae similar to the CAPSENSE™ traces. The recommended pull-up resistor value for I²C communication lines is 4.7 kΩ. If more than 330 Ω is placed in series on these lines, the V_{IL} and V_{IH} voltage levels may fall out of specifications. 330 Ω will not affect I²C operation as the V_{IL} level still remains within the I²C specification limit of 0.3 V_{DD} when PSoC™ outputs a LOW.

7 Design considerations

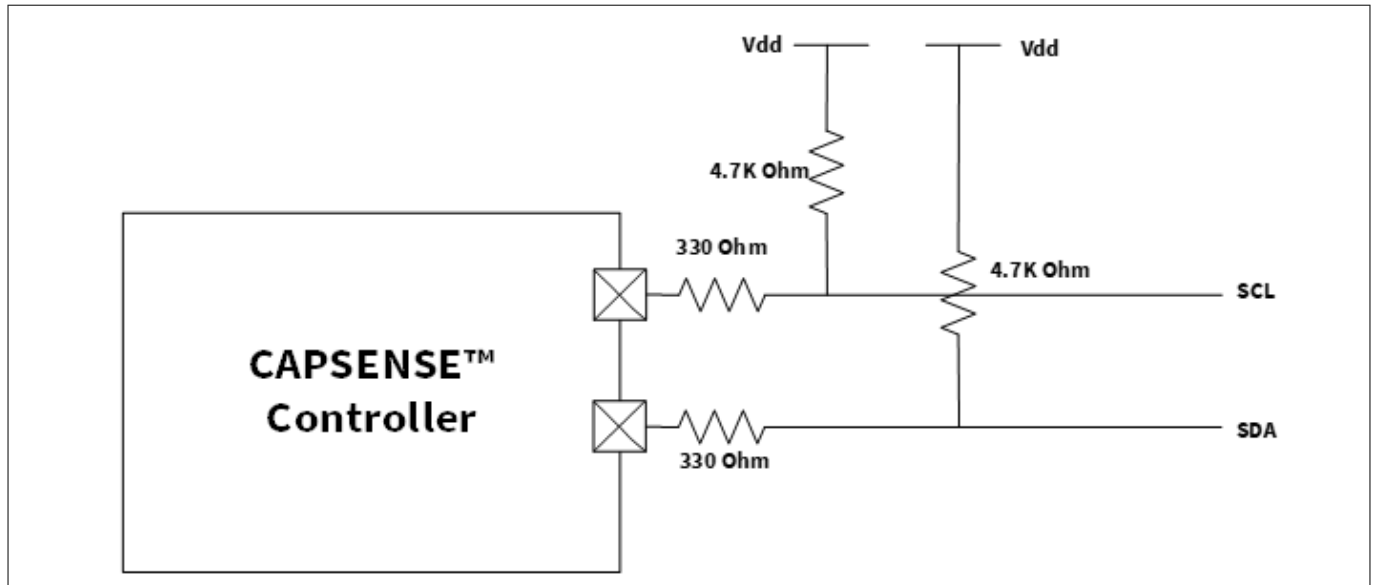

Figure 165 Series resistors on communication lines

Trace length

Long traces can pick up more noise than short traces. Long traces also add to C_p . Minimize the trace length whenever possible.

Current loop area

Another important layout consideration is to minimize the return path for currents. This is important as the current flows in loops. Unless there is a proper return path for high-speed signals, the return current will flow through a longer return path forming a larger loop, thus leading to increased emissions and interference.

If you isolate the CAPSENSE™ ground hatch and the ground fill around the device, the sensor-switching current may take a longer return path, as [Figure 166](#) shows. As the CAPSENSE™ sensors are switched at a high frequency, the return current may cause serious EMC issues. Therefore, you should use a single ground hatch, as [Figure 167](#) shows.

7 Design considerations

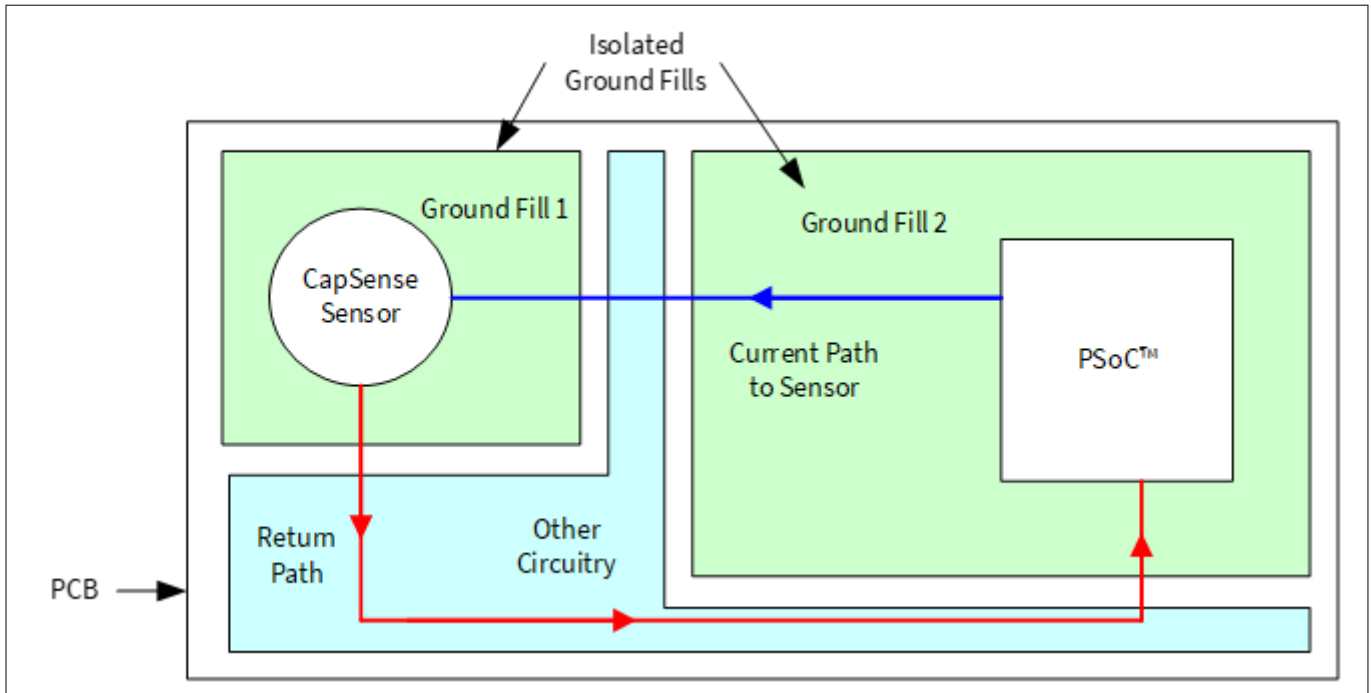

Figure 166 Improper current loop layout

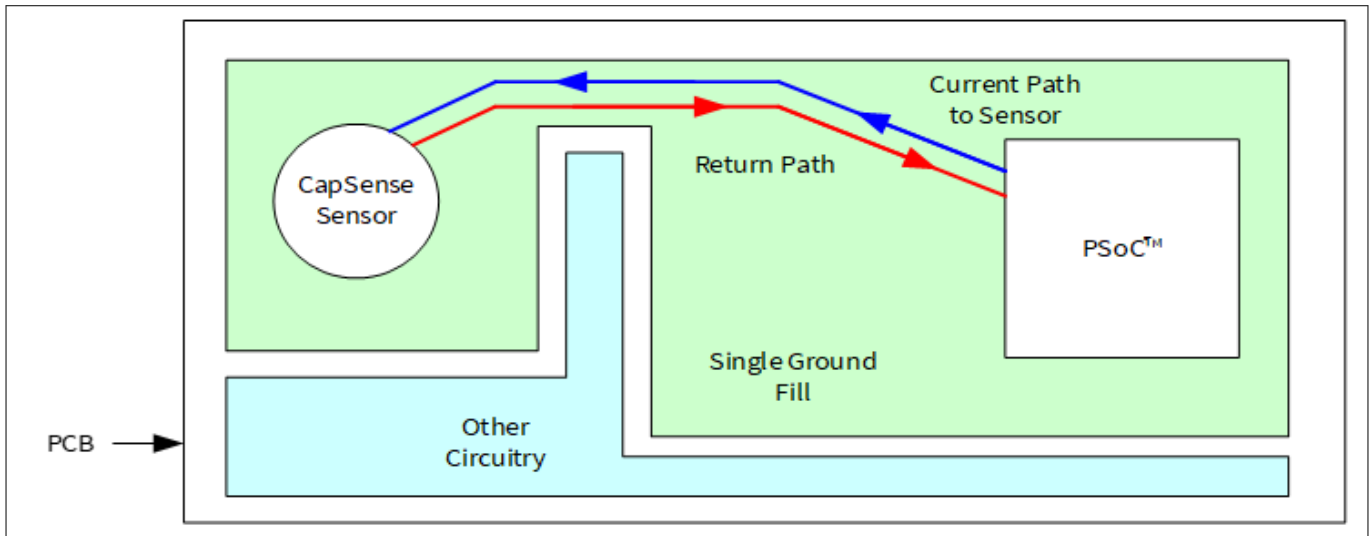

Figure 167 Proper current loop layout

RF source location

If your system has a circuit that generates RF noise, such as a switched-mode power supply (SMPS) or an inverter, you should place these circuits away from the CAPSENSE™ interface. You should also shield such circuits to reduce the emitted RF. Figure 168 shows an example of separating the RF noise source from the CAPSENSE™ interface.

7 Design considerations

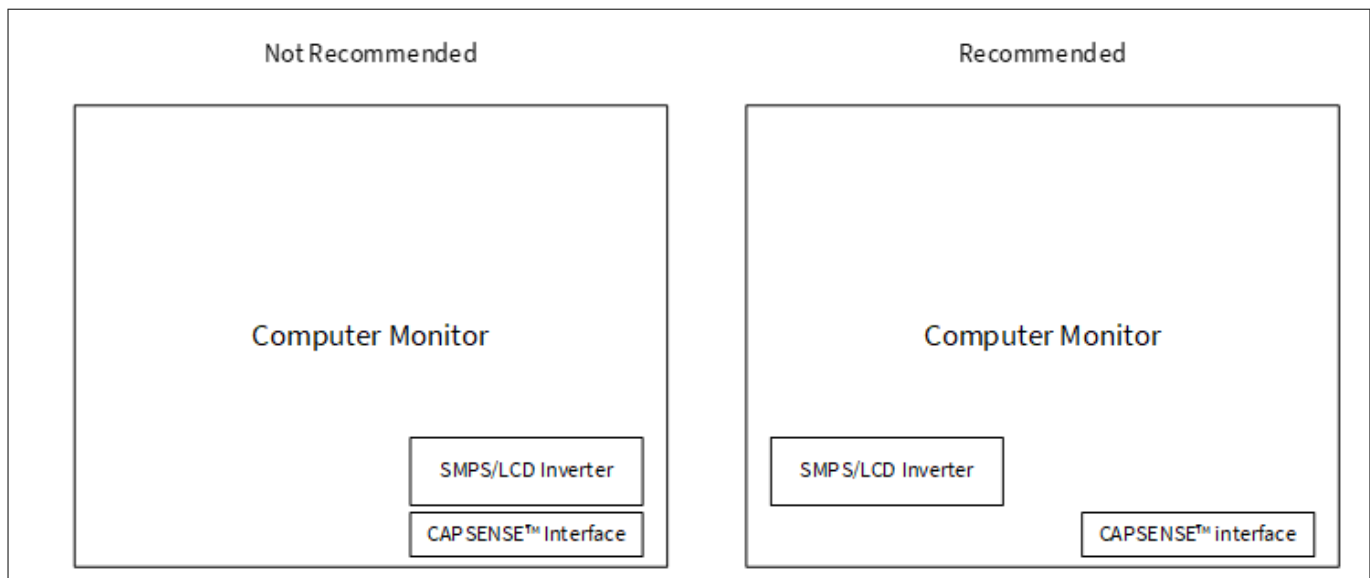

Figure 168 Separating noise sources

Firmware considerations

The following parameters affect Radiated Emissions (RE) in a CAPSENSE™ system:

- Device operating voltage
- Device operation frequency
- Sensor switching frequency
- Shield signal
- Sensor scan time
- Sense Clock Source Inactive sensor termination

The following sections explain the effect of each parameter.

Device operating voltage

The emission is directly proportional to the voltage levels at which switching happens. Reducing the operating voltage helps to reduce the emissions as the amplitude of the switching signal at any output pin directly depends on the operating voltage of the device.

PSoC™ allows you to operate at lower operating voltages, thereby reducing the emissions. [Figure 169](#) and [Figure 170](#) show the impact of operating voltage on radiated emissions. Because $IMO = 24$ MHz, there is a spike at 24 MHz and the other spikes are caused by different hardware and firmware operations of the device.

7 Design considerations

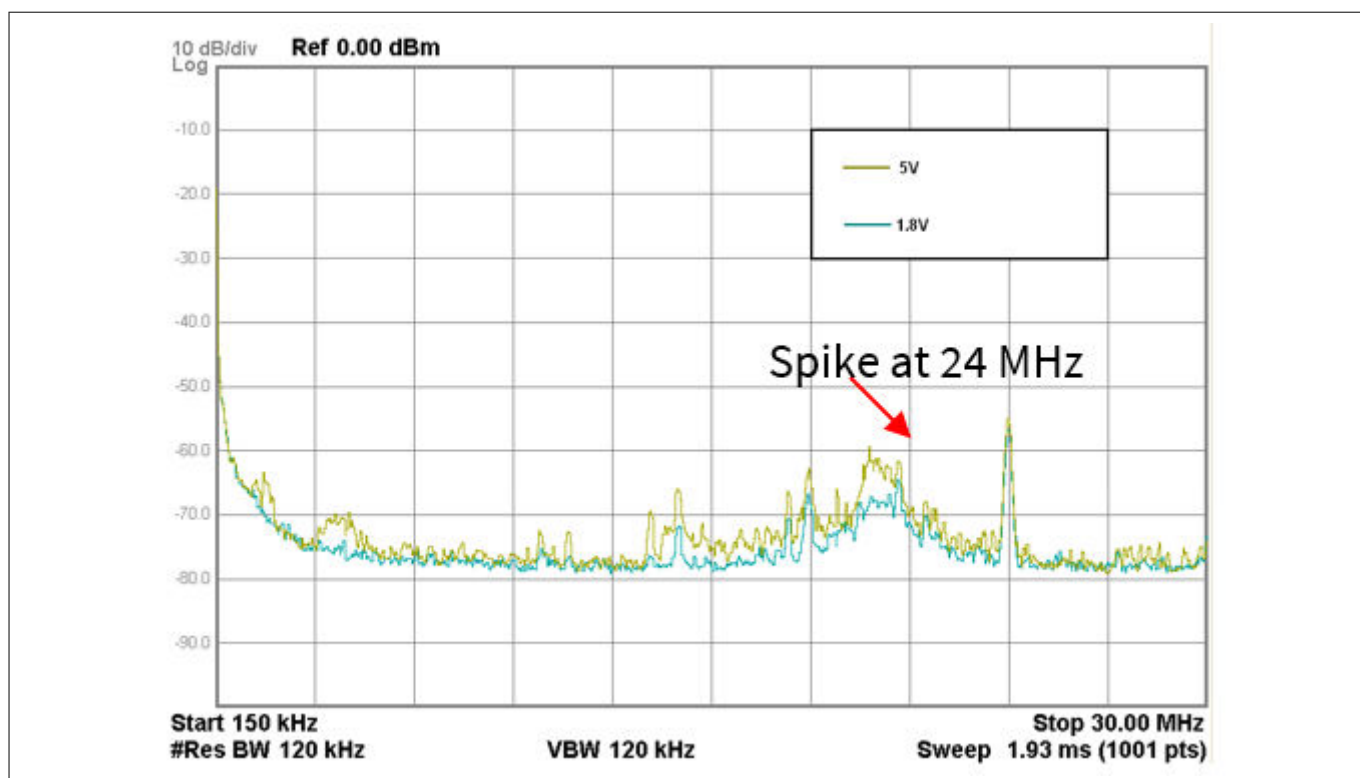

Figure 169 Effect of V_{DD} on radiated emissions (150 kHz – 30 MHz)

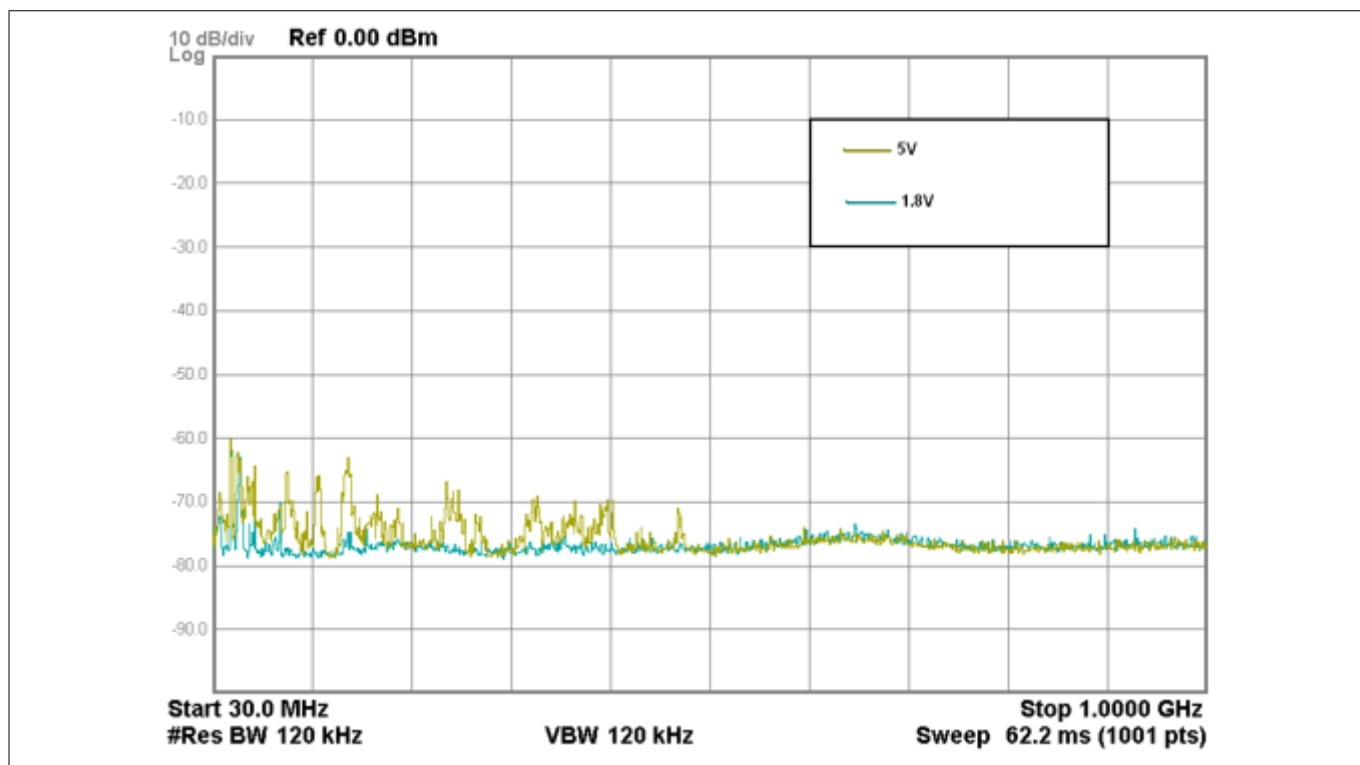

Figure 170 Effect of V_{DD} on radiated emissions (30 MHz – 1 GHz)

Note: Frequency axis is in log scale.

7 Design considerations

Device operating frequency

Reducing the system clock frequency (IMO frequency) reduces radiated emissions. However, reducing the IMO frequency may not be feasible in all applications because the IMO frequency impacts the CPU clock and all other system timings. Choose a suitable IMO frequency based on your application.

Sensor-switching frequency

Reducing the sensor-switching frequency (see [Sense Clock](#)) also helps to reduce radiated emissions. See [Figure 171](#) and [Figure 172](#). Because IMO = 24 MHz, there is a spike at 24 MHz and the other spikes are caused by different hardware and firmware operations of the device.

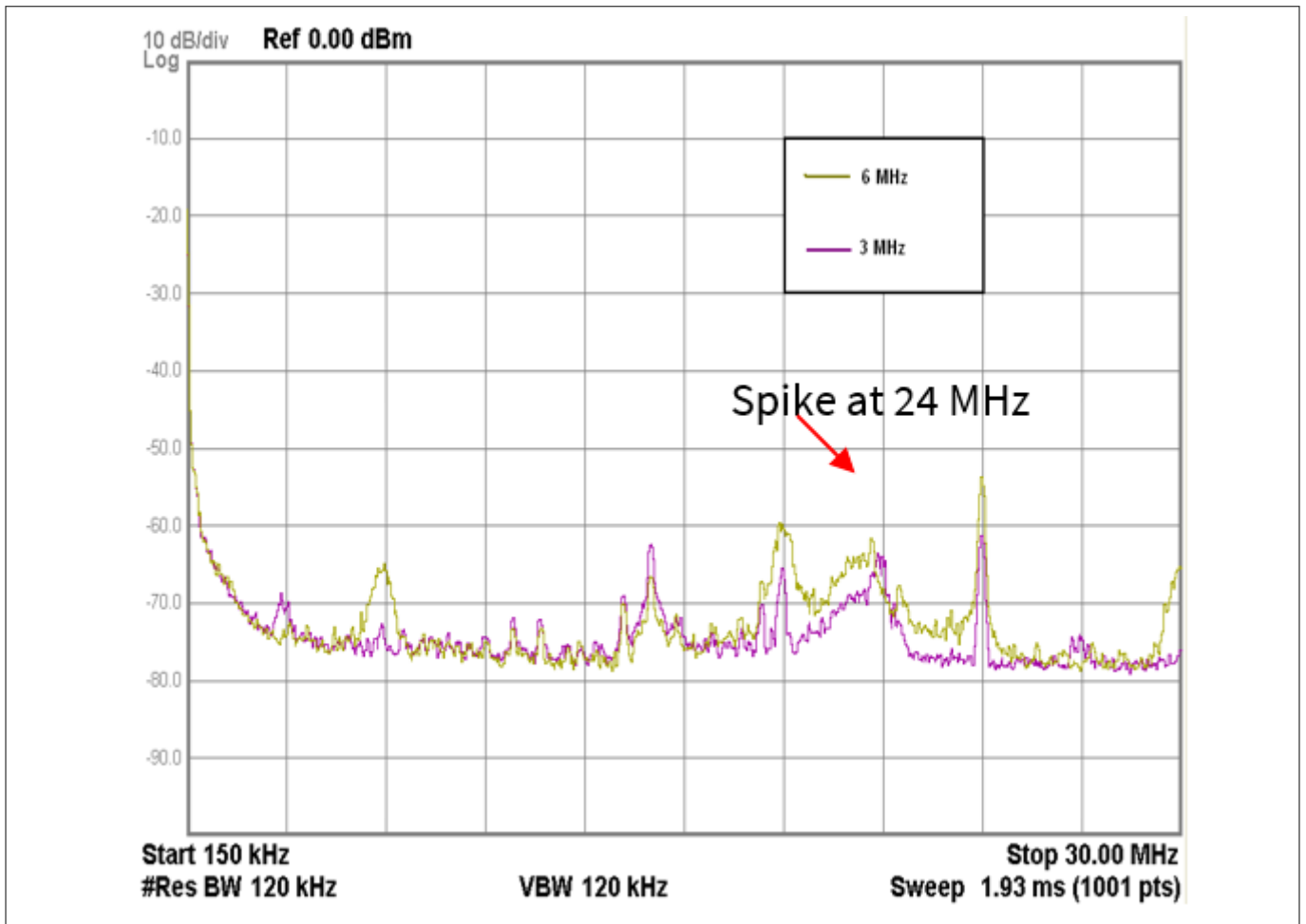

Figure 171 Effect of sensor-switching frequency on radiated emissions (150 kHz – 30 MHz)

7 Design considerations

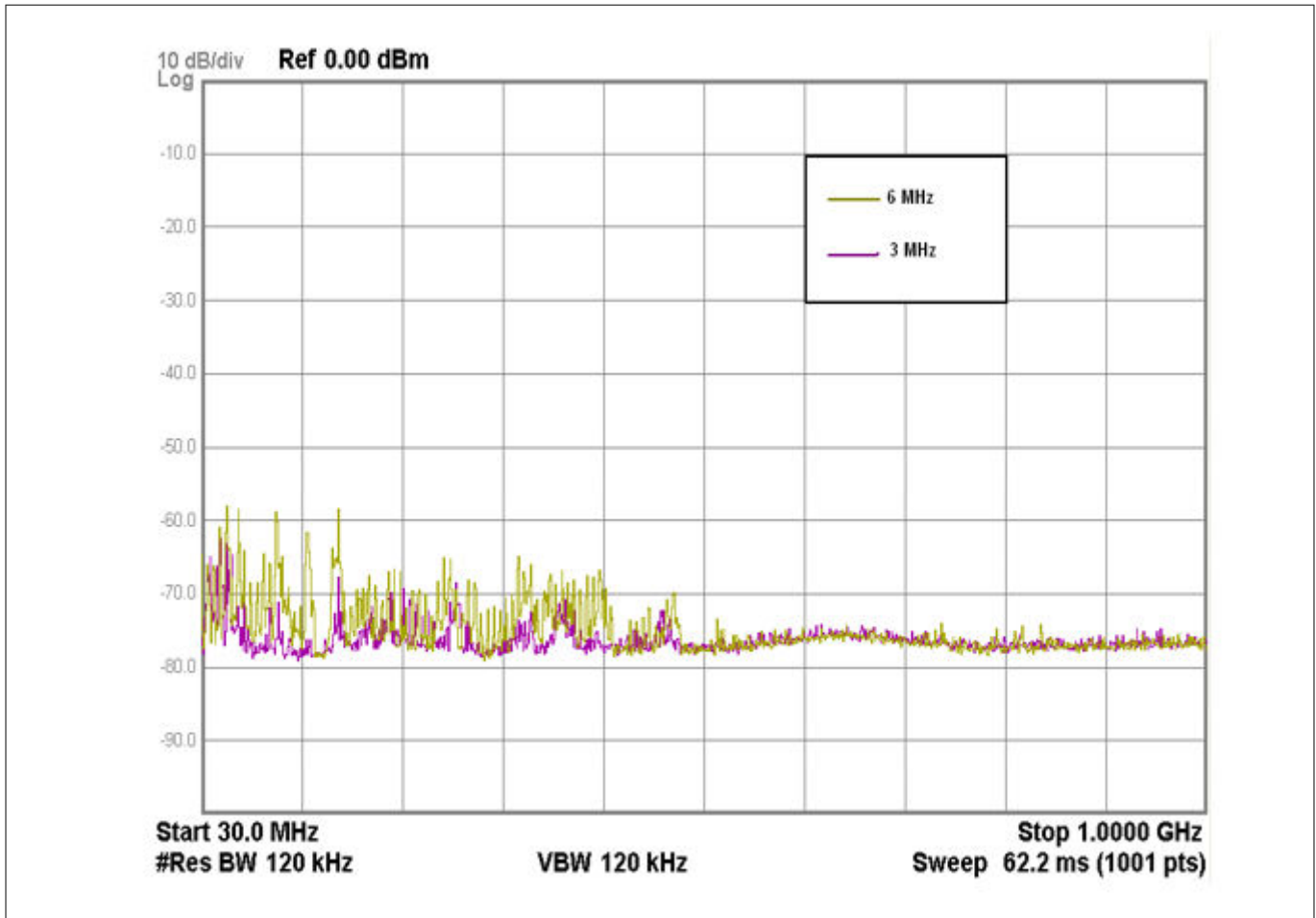

Figure 172 Effect of sensor-switching frequency on radiated emissions (30 MHz – 1 GHz)

Note: Frequency axis is in log scale.

Pseudo random sense clock

The PSoC™ 4 device supports PRS-based sense clock generation. A PRS is used instead of a fixed clock source to attenuate emitted noise on the CAPSENSE™ pins by reducing the amount of EMI created by a fixed-frequency source and to increase EMI immunity from other sources and their harmonics.

Spread spectrum sense clock

In addition to the PRS-based clock generation, the PSoC™ 4 S-Series, PSoC™ 4100S Plus, PSoC™ 4100PS, and PSoC™ 6 MCU family of devices supports a unique feature called spread spectrum sense clock generation, in which the sense clock frequency is spread over a desired range. This method will help to reduce the peaks and spread out the emissions over a range of frequencies. The spread spectrum clock can be enabled by selecting the **Sense Clock Source** as **SSCn**. The range of frequency spread is decided by the length of the register. For more details on the spread spectrum clock generation in the PSoC™ 4 S-Series, PSoC™ 4100S Plus, and PSoC™ 4100PS family, see the Spread spectrum clock section in the CAPSENSE™ chapter of the respective device [Technical reference manual](#).

7 Design considerations

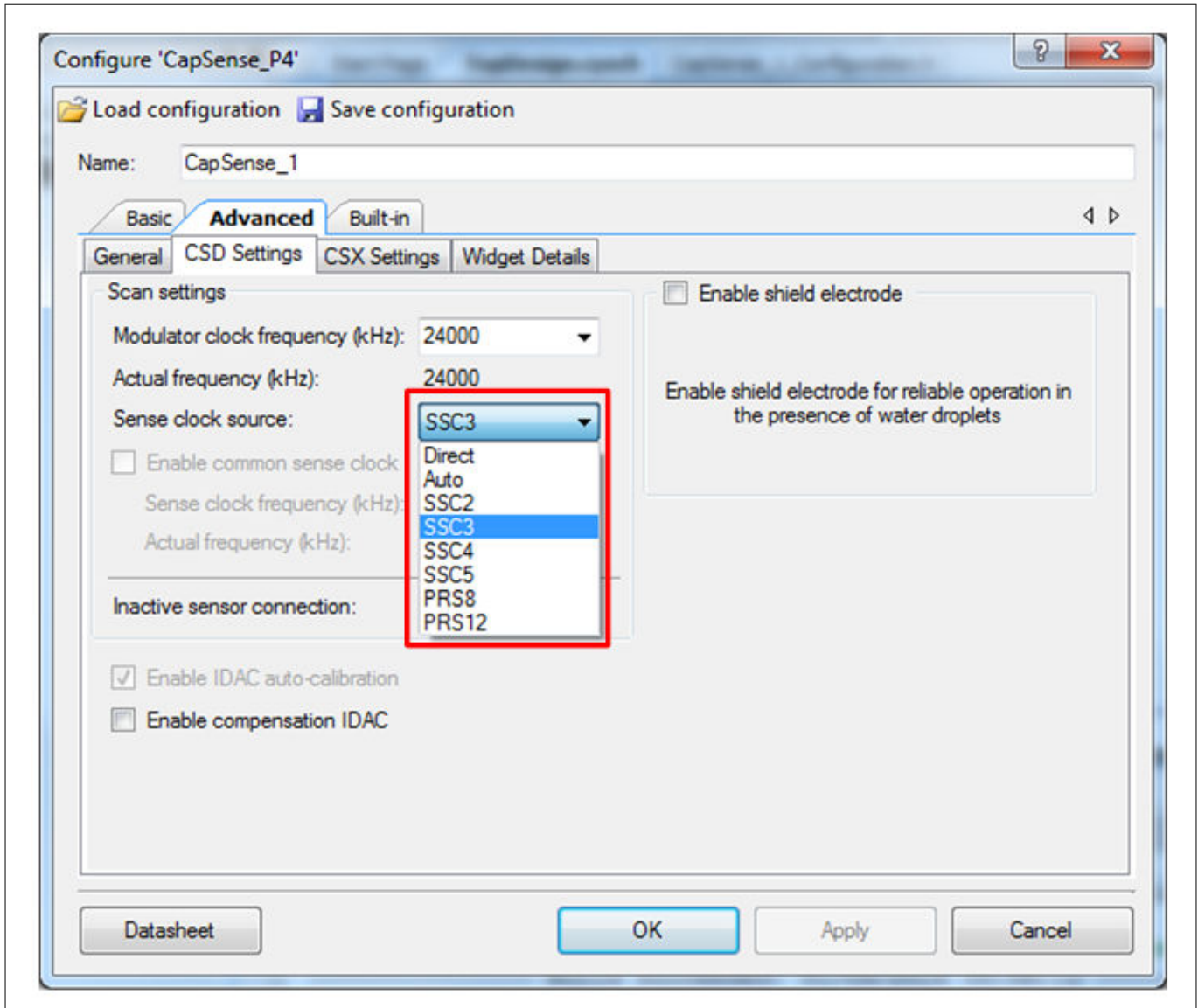

Figure 173 Sense clock sources in PSoC™ 4 S-Series, PSoC™ 4100S Plus, and PSoC™ 4100PS family

Shield signal

Shield signal

Enabling the shield signal (see [Driven shield signal and shield electrode](#)) on the hatch pattern increases the radiated emissions. Enable the driven-shield signal only for liquid-tolerant, proximity-sensing, or high-parasitic-capacitance designs. Also, if the shield must be used, ensure that the shield electrode area is limited to a width of 1 cm from the sensors, as [Figure 154](#) shows.

[Figure 174](#) and [Figure 175](#) show the impact of enabling the driven-shield signal on the hatch pattern surrounding the sensors on radiated emissions.

Note: In these figures, the hatch pattern is grounded when the driven-shield signal is disabled. Because $f_{MO} = 24\text{ MHz}$, there is a spike at 24 MHz and the other spikes are caused by different hardware and firmware operations of the device.

7 Design considerations

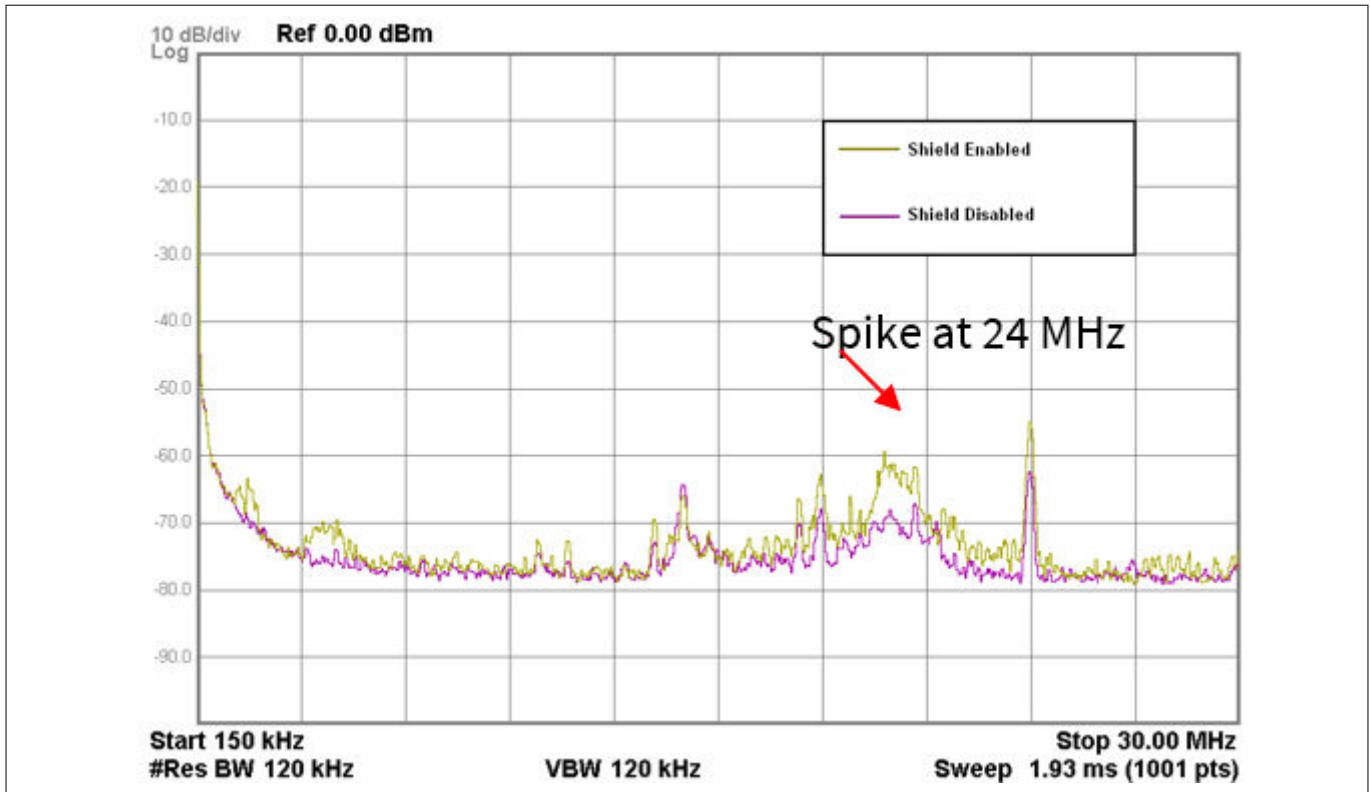

Figure 174 Effect of shield electrode on radiated emissions (150 kHz – 30 MHz)

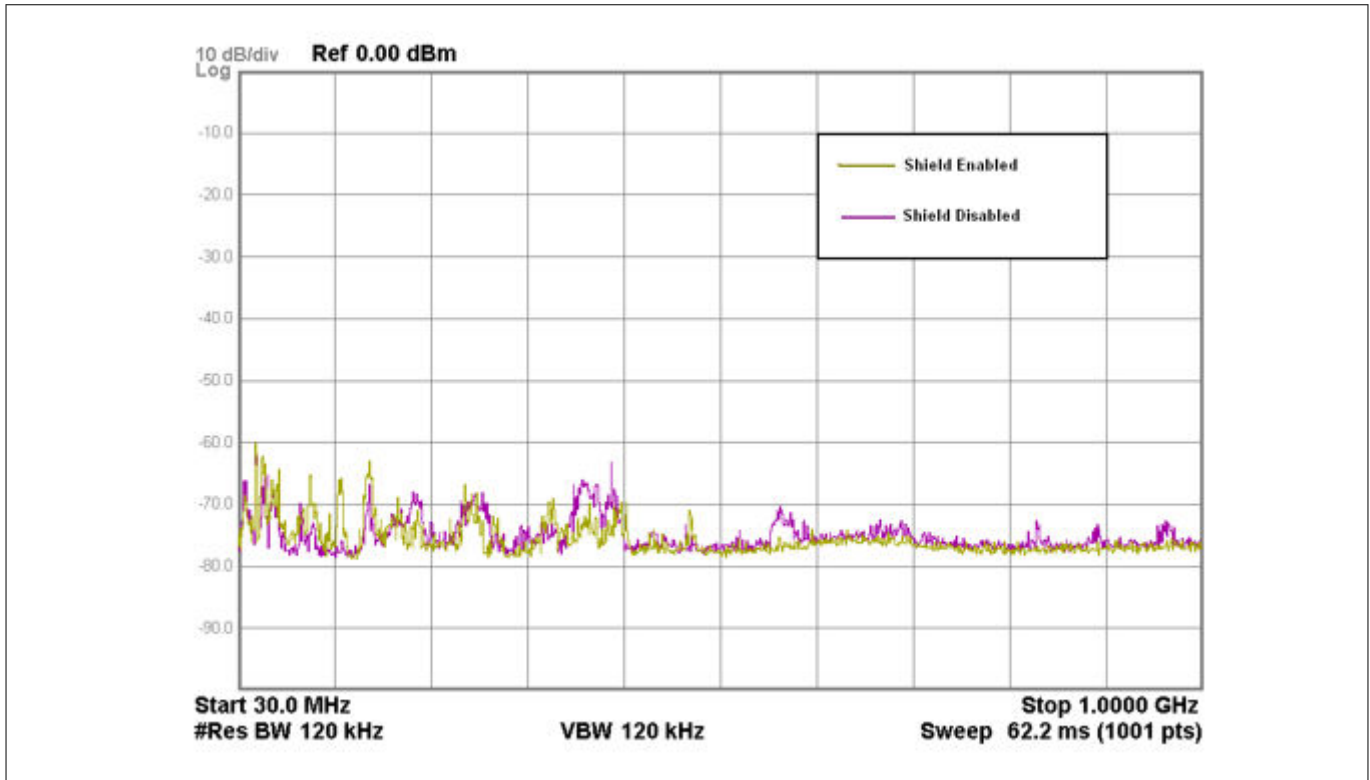

Figure 175 Effect of shield electrode on radiated emissions (30 MHz – 1 GHz)

Note: Frequency axis is in log scale.

7 Design considerations

Sensor scan time

Reducing the sensor scan time reduces the average radiated emissions. The sensor-scan time depends on the scan resolution and modulator clock divider (see Equation 9). Increasing the scan resolution or modulator clock divider increases the scan time.

Figure 176 and Figure 177 show the impact of sensor scan time on radiated emissions. Note that, here, the sensor scan time was varied by changing the scan resolution. Because IMO = 24 MHz, there is a spike at 24 MHz and the other spikes are caused by different hardware and firmware operations of the device.

Table 44 Sensor scan time

Parameter	Total scan time for five buttons	
	0.426 ms	0.106 ms
Modulation clock divider	2	2
Scan resolution	10 bits	8 bits
Individual sensor scan time	0.085 ms	0.021 ms

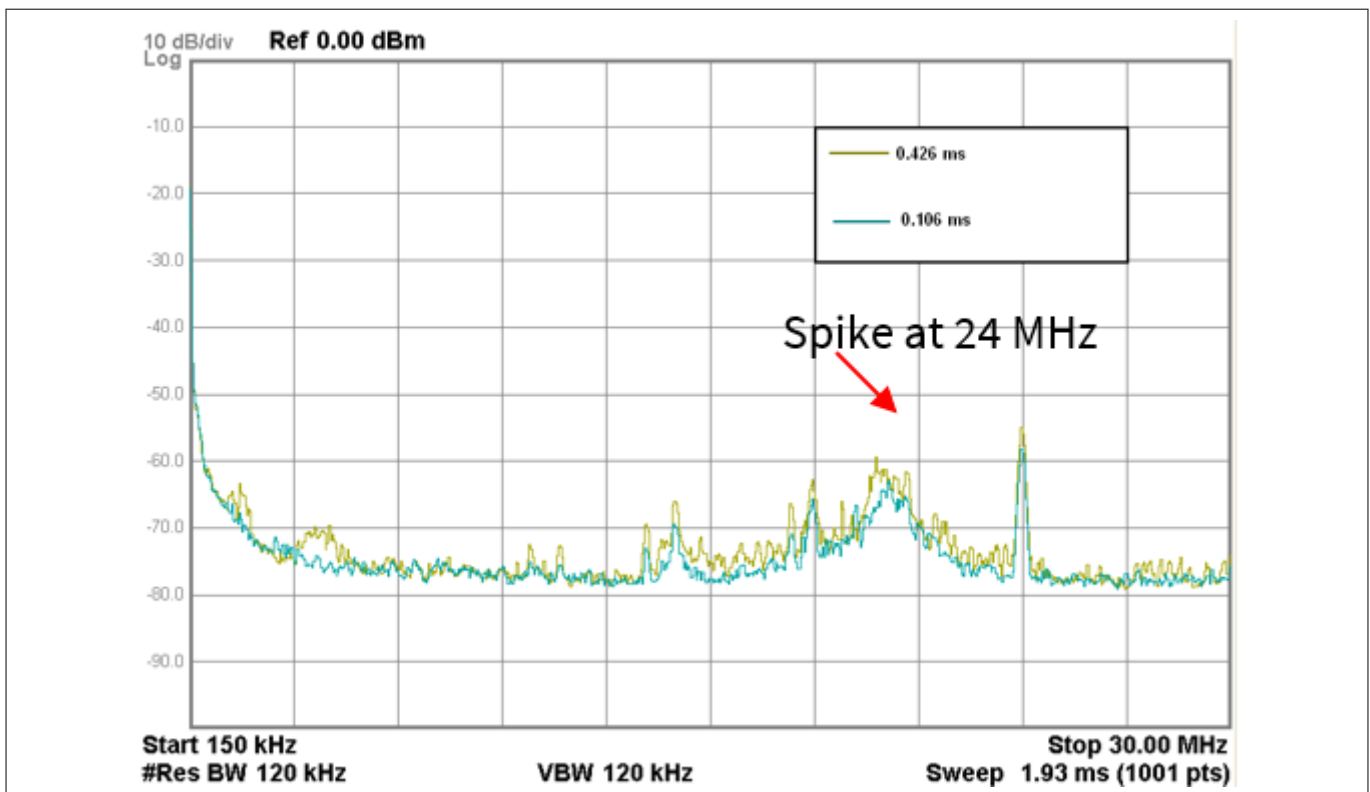

Figure 176 Effect of scan time on radiated emissions (150 kHz – 30 MHz)

7 Design considerations

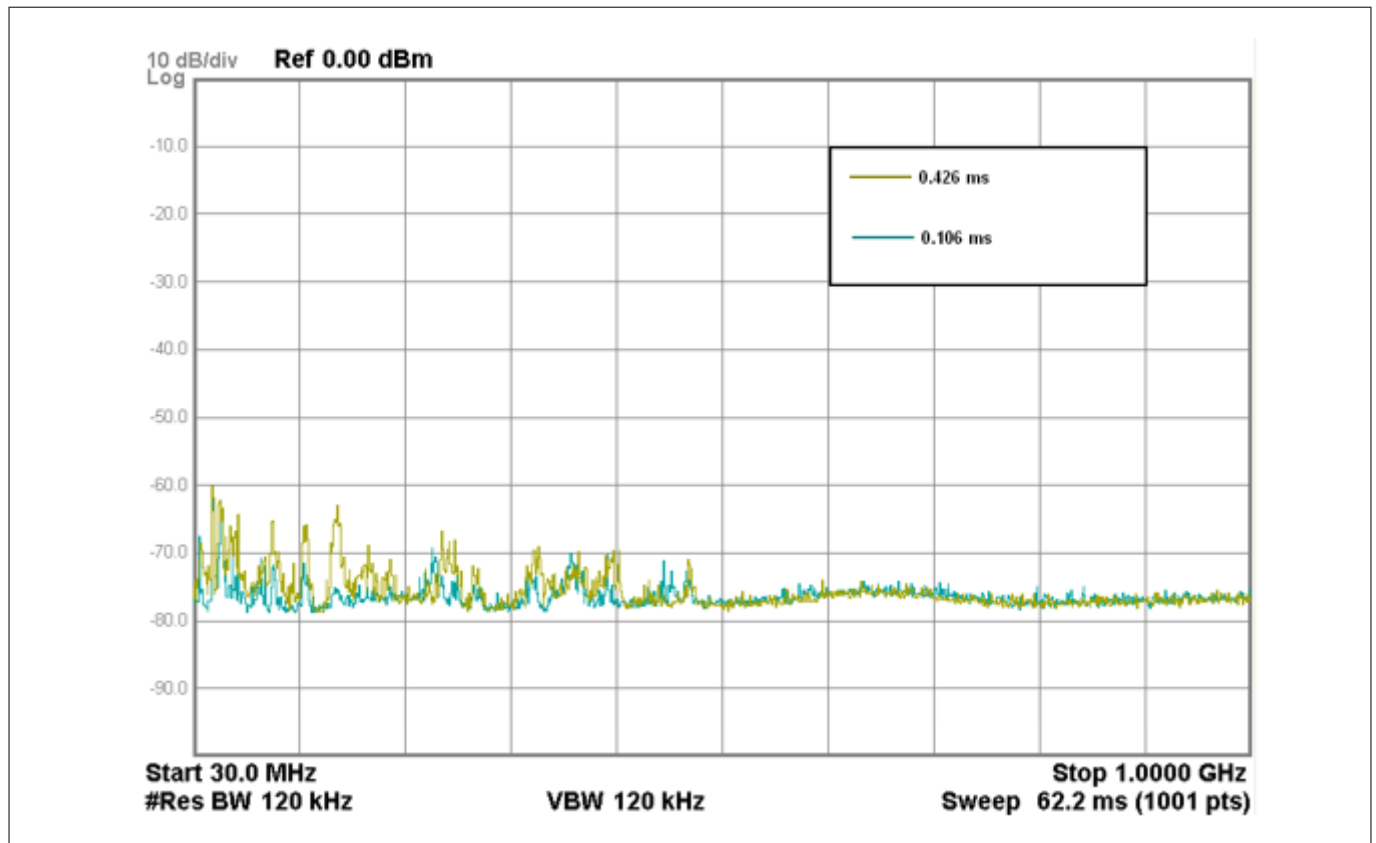

Figure 177 Effect of scan time on radiated emissions (30 MHz – 1 GHz)

Note: Frequency axis is in log scale.

Sense clock source

Using PRS instead of direct clock drive as sense clock source spreads the radiated spectrum and hence reduces the average radiated emissions. See [Figure 178](#) and [Figure 179](#). Because IMO = 24 MHz, there is a spike at 24 MHz and the other spikes are caused by different hardware and firmware operations of the device.

7 Design considerations

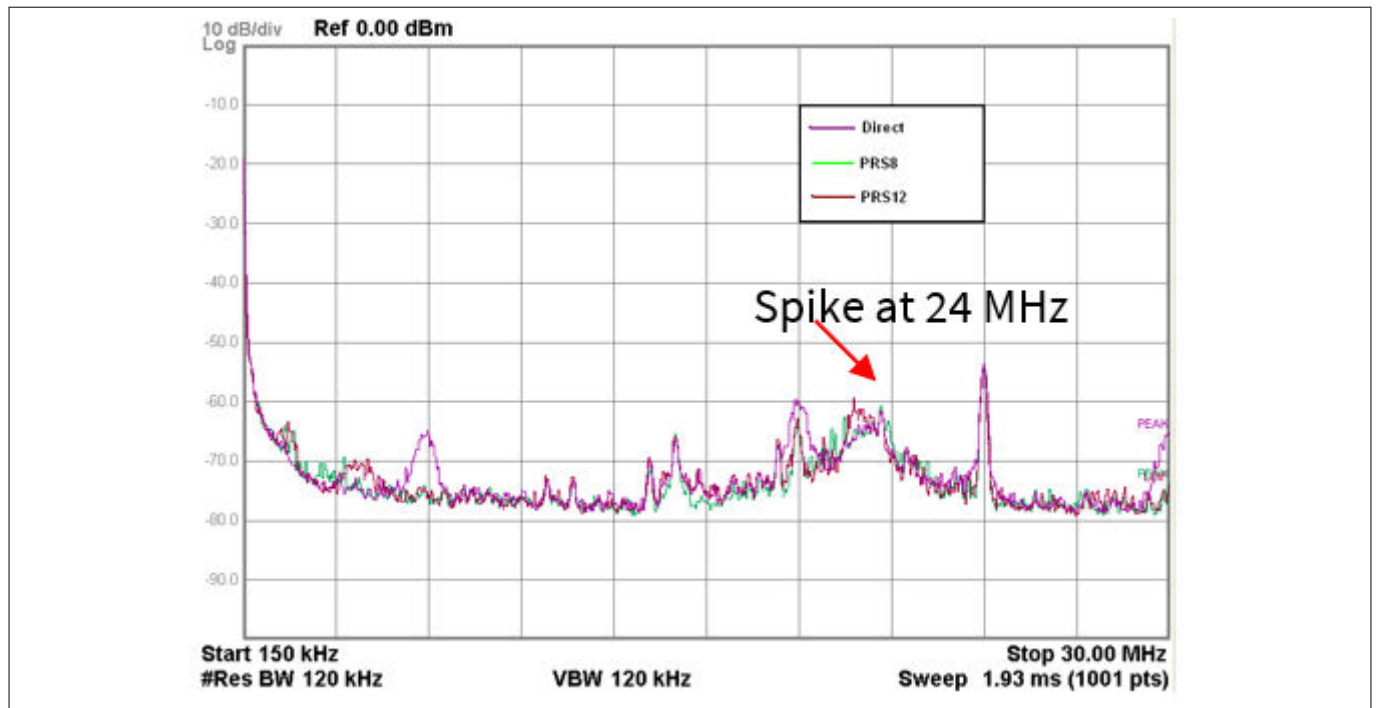

Figure 178 Effect of sense clock source on radiated emissions (150 kHz – 30 MHz)

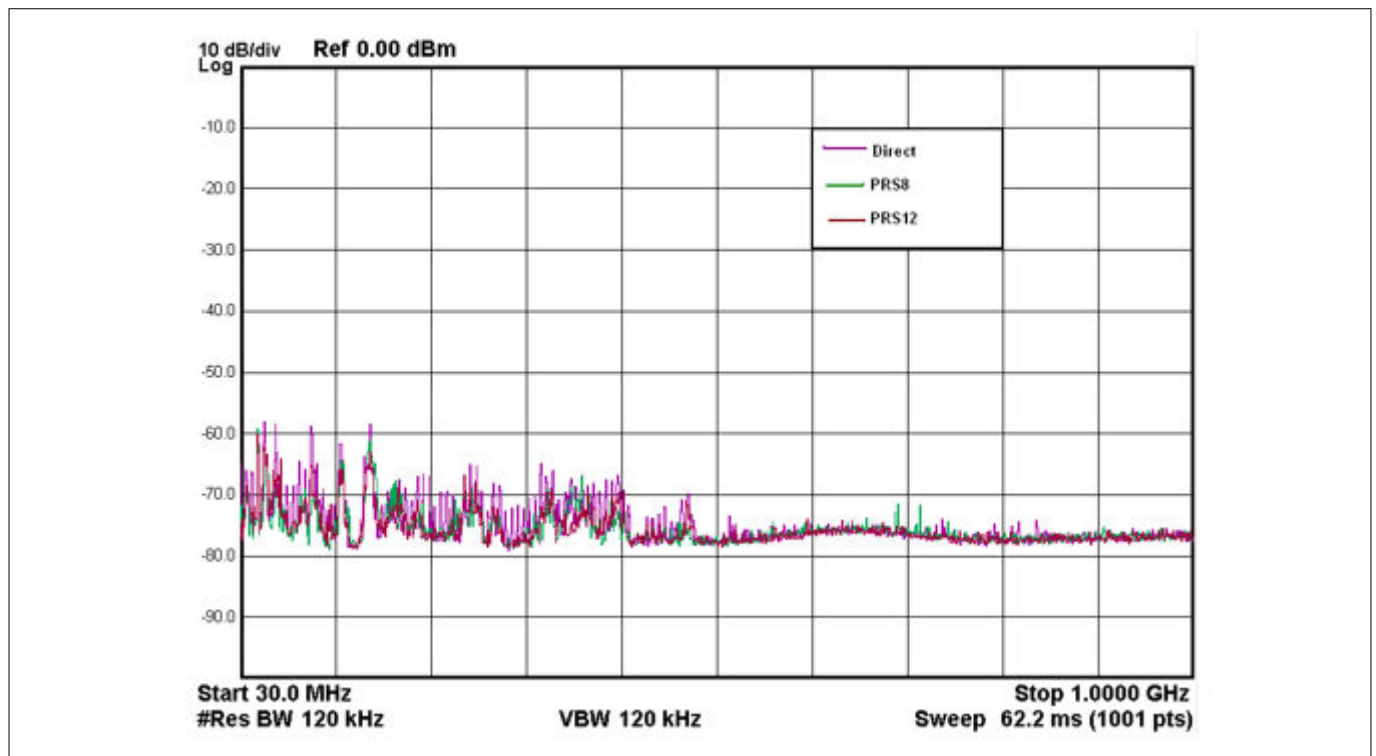

Figure 179 Effect of sense clock source on radiated emissions (30 MHz – 1 GHz)

Note: Frequency axis is in log scale.

7 Design considerations

Inactive sensor termination

Connecting inactive sensors to ground reduces the radiated emission by a greater degree than connecting them to the shield. Figure 180 and Figure 181 show the impact of different inactive sensor terminations on radiated emission. Because IMO = 24 MHz, there is a spike at 24 MHz and the other spikes are caused by different hardware and firmware operations of the device.

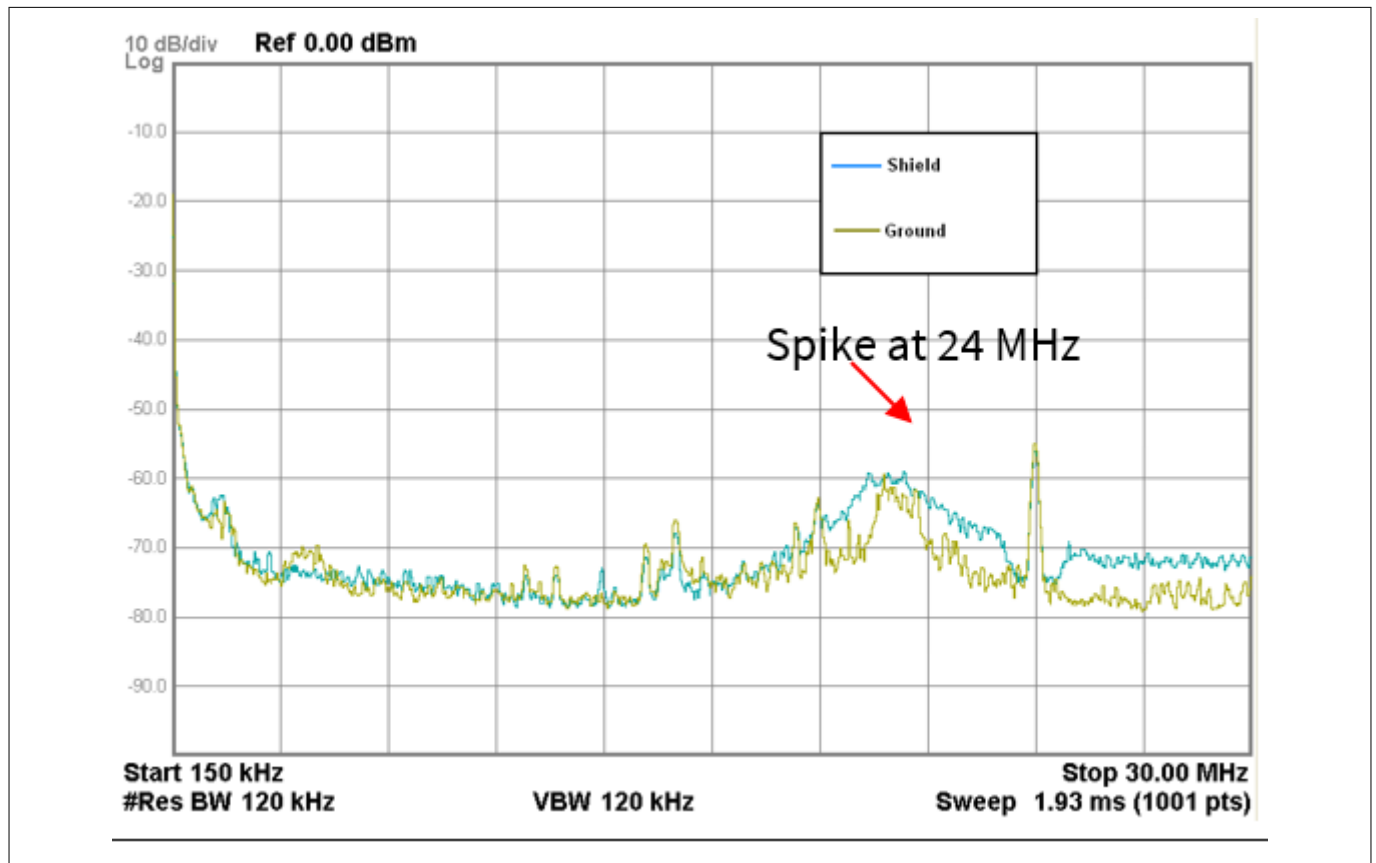

Figure 180 Effect of inactive sensor termination on radiated emissions (150 kHz – 30 MHz)

7 Design considerations

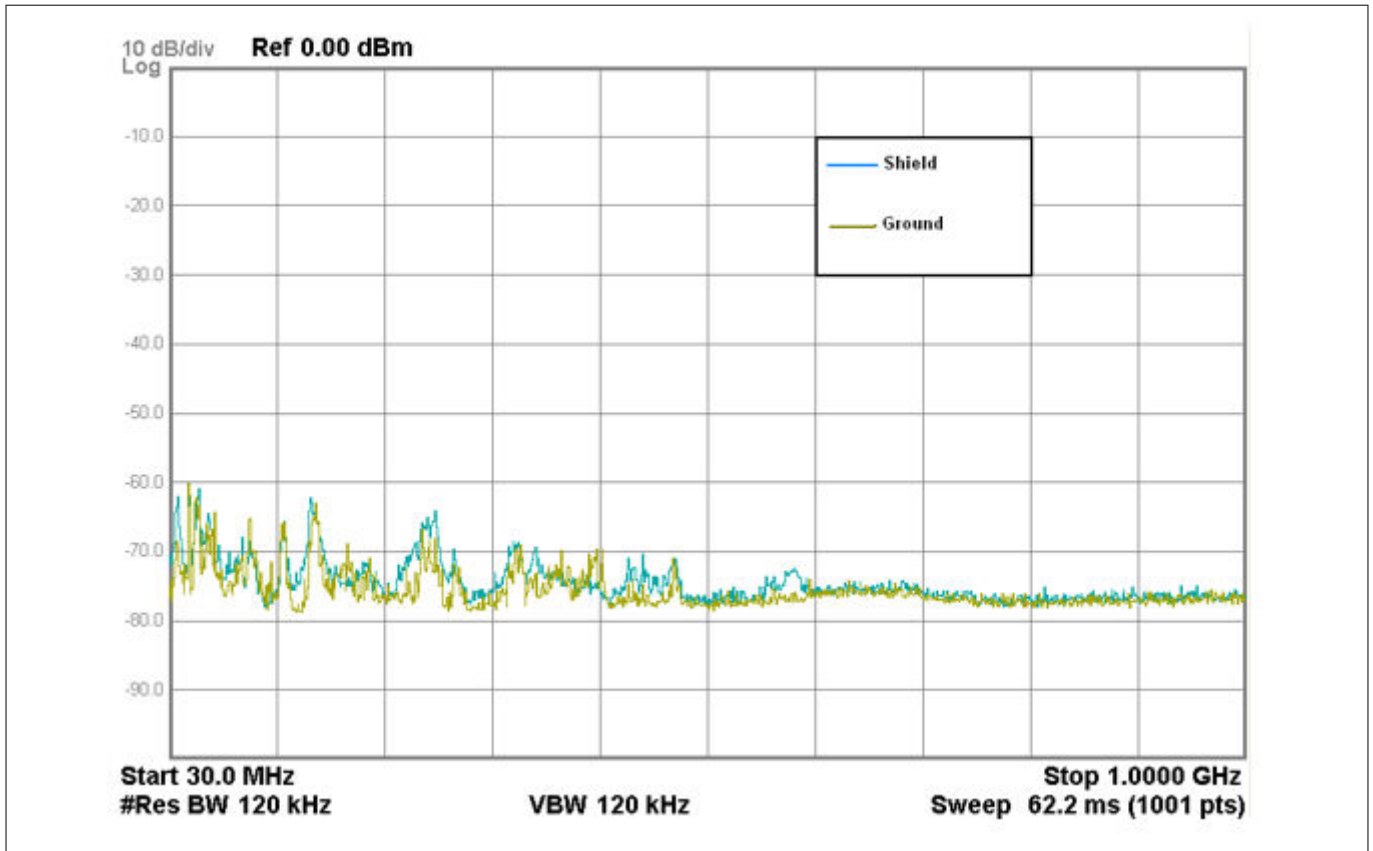

Figure 181 Effect of inactive sensor termination on radiated emissions (30 MHz – 1 GHz)

Note: Frequency axis is in log scale.

7.5.3.2.2 Conducted RF noise

The noise current that enters the CAPSENSE™ system through the power and communication lines is called conducted noise. You can use the following techniques to reduce the conducted RF noise.

- Use decoupling capacitors on the power supply pins to reduce the conducted noise from the power supply. See section [Power supply layout recommendations](#) and the [Device datasheet](#) for details
- Provide GND and VDD planes on the PCB to reduce current loops
- If the PSoC™ PCB is connected to the power supply using a cable, minimize the cable length and consider using a shielded cable

To reduce high-frequency noise, place a ferrite bead around power supply or communication lines.

7.6 Effect of grounding

7.6.1 CSX method

The equivalent capacitances formed in the CSX method when a finger touches the CSX sensor is shown in [Figure 182](#). From [Figure 182](#), current drawn from the IDAC (IRX) has two components: I_{mt} and I_{sc} . These two components depend on the ratio of C_{bodyDG}/C_{fs} . Because the raw count depends on the amount of current drawn from IDAC, the increase and decrease of C_{bodyDG}/C_{fs} will affect the raw count of the sensor and cause a

7 Design considerations

sudden change in the behavior on some conditions. To understand it better, consider two extreme conditions which cause $C_{bodyDG} \gg C_{fs}$ and $C_{bodyDG} \ll C_{fs}$.

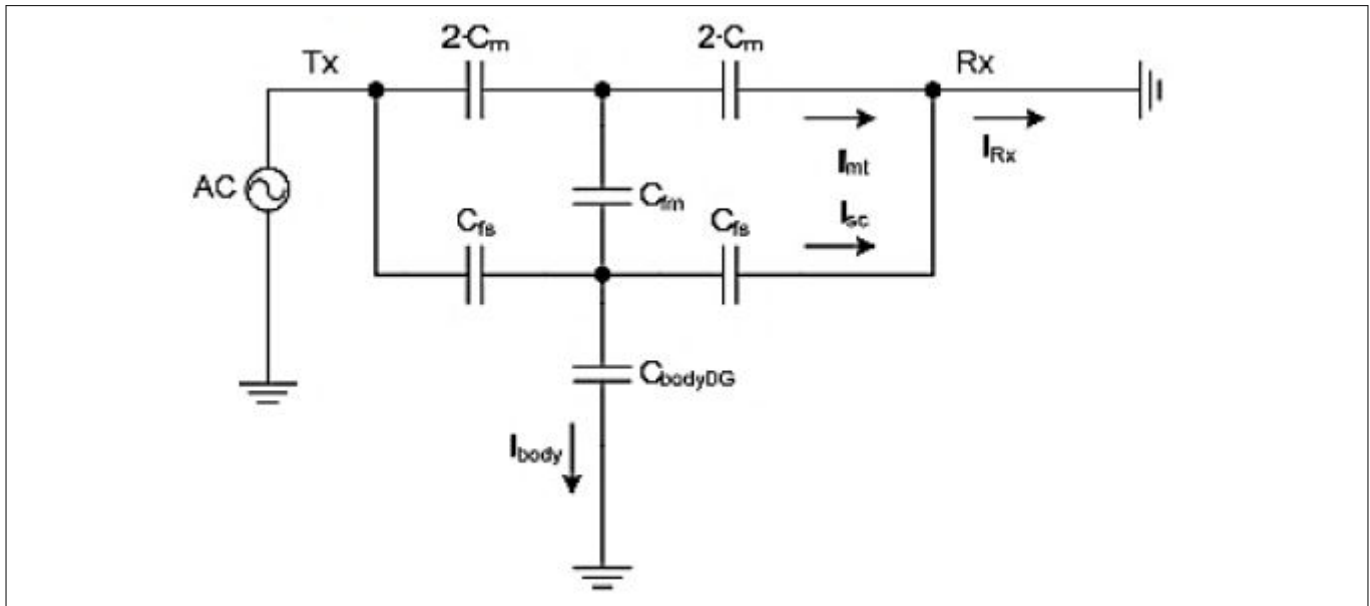

Figure 182 Equivalent circuit of the CSX sensor when finger is placed on the button

Where,

C_M = Mutual capacitance between the Rx and Tx electrode

C_{fs} = Capacitance formed between the surface of the finger and electrode

C_{fm} = Virtual capacitance which reduces the mutual-capacitance C_M due to placing a finger

C_{bodyDG} = Body capacitance relative to the device ground

$$I_{RX} = I_{mt} + I_{sc}$$

Equation 82 Current drawn from IDAC in CSX method

I_{mt} is due to the effective mutual-capacitance between the Tx and Rx electrode.

I_{sc} = Parasitic current that flows due to the capacitance formed between the sensor and finger

7.6.1.1 $C_{bodyDG} \gg C_{fs}$

Because $C_{bodyDG} \gg C_{fs}$, you can replace C_{bodyDG} with a ground conductor; the resulting equivalent circuit appears as shown in Figure 183. Whenever there is a finger touch, the current drawn from the IDAC is directly dependent upon the effective mutual-capacitance between the Tx and Rx. This condition is observed in a good board design.

7 Design considerations

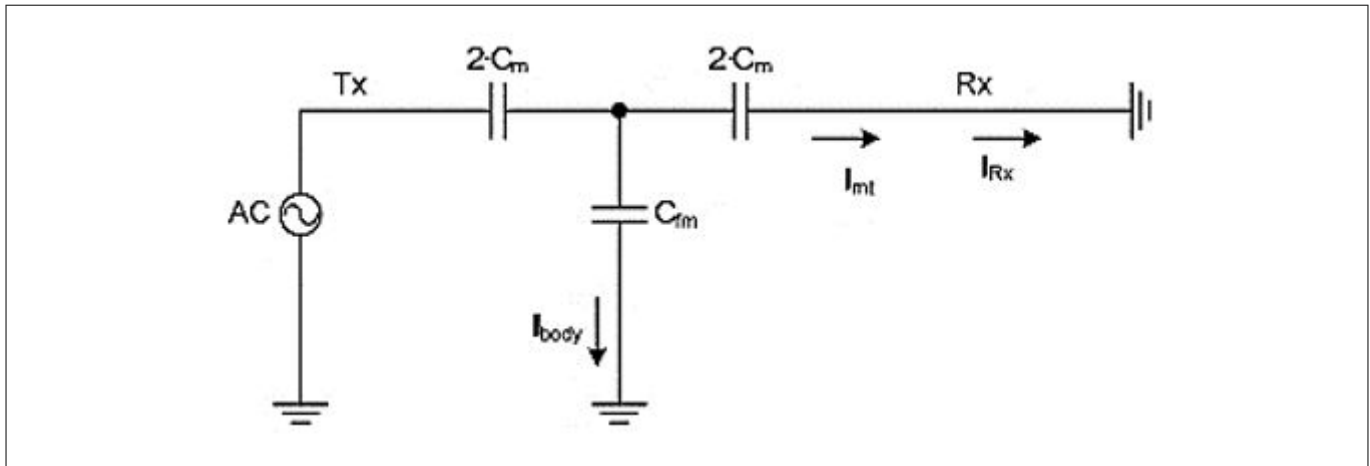

Figure 183 Equivalent circuit of the CSX sensor when $C_{bodyDG} \gg C_{fs}$

7.6.1.2 $C_{bodyDG} \ll C_{fs}$

This condition ($C_{bodyDG} \ll C_{fs}$) is observed when a finger touches a CSX button with a very thin overlay or no overlay, or a finger touching the Rx and Tx electrodes directly, or a water drop being present on the Rx and Tx electrode only. Because $C_{bodyDG} \ll C_{fs}$, you can remove C_{bodyDG} ; the equivalent circuit for this case is as shown in Figure 184. In this condition, the capacitance introduced by the finger to the electrode C_{fs} is very high compared to the capacitance of the finger relative to the device ground C_{bodyDG} .

From Figure 184, it forms a balanced bridge circuit. Due to this, no current flows through C_{fm} , and also due to increase in C_{fs} , I_{sc} increases and thus additional current is drawn from the IDAC. This causes an unexpected behavior of decrease in the raw count.

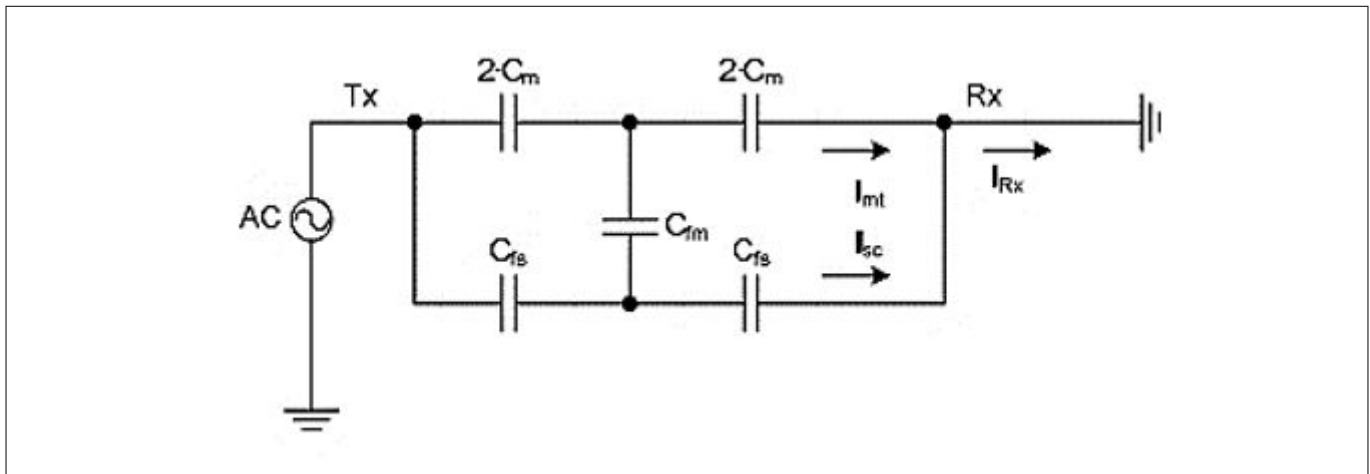

Figure 184 Equivalent circuit of the CSX sensor when $C_{body} \ll C_{fs}$

For CSX sensors, design should focus on increasing the ratio of C_{bodyDG}/C_{fs} . Following are the examples for increasing the ratio of C_{bodyDG}/C_{fs} :

1. C_{bodyDG}/C_{fs} ratio depends on the thickness of the overlay, size of the sensor, and many other factors. By experimental data, you are recommended not to use overlay thickness below 0.5 mm for CSX sensor. See [Overlay thickness](#)

7 Design considerations

2. If the sensor is surrounded by hatch fill connected to ground, there is a lower chance that $C_{bodyDG} \ll C_{fs}$. Therefore, ensure good ground in the design. Follow the best practices for the PCB layout guidelines described in this chapter
3. In the design, it is recommended to isolate the trace lines of Rx and Tx electrode, external capacitors, and resistors of the CSX touch sensing system from any conducting surface or a finger touch to avoid direct interaction. Not following this recommendation may cause $C_{bodyDG} \ll C_{fs}$

7.6.2 CSD method

The equivalent capacitances formed in the CSD method when a finger touches the CSD sensor is shown in [Figure 185](#). It shows that the current drawn from the IDAC directly depends on the capacitance introduced by the finger touch. I_{CP} is a fixed component and I_{CF} depends on C_F, C_{BG}, C_{GE} . From [Sigma-delta converter](#), the raw count depends on the amount of current drawn from IDAC. To understand it better, consider two scenarios of an AC/ DC mains-powered application and a battery-powered application.

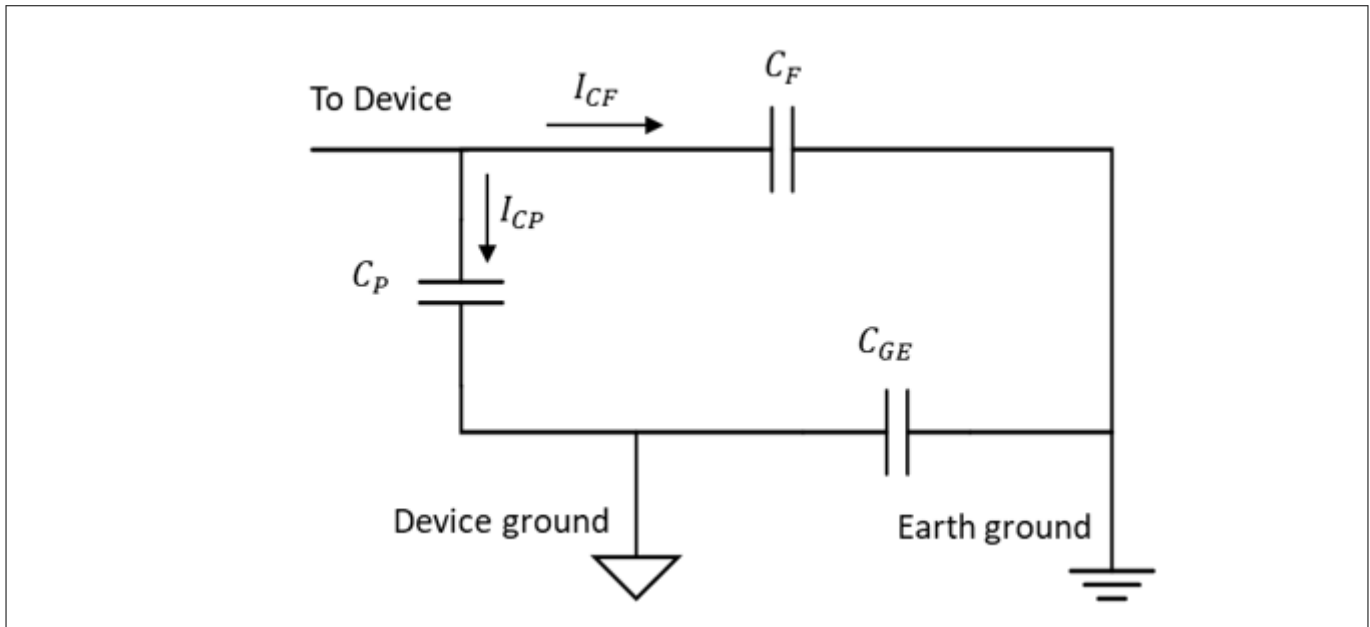

Figure 185 Equivalent circuit of the CSD sensor

$$I = I_{CP} + I_{CF}$$

Equation 83 Current drawn from IDAC in CSD method

7.6.2.1 AC/DC-powered application

In an AC / DC-powered application using the mains supply, device ground is strongly coupled to earth ground. Thus, you can replace C_{GE} with a conductor and C_{BG} is usually 100 pF to 200 pF. Since C_{BG} is large when compared to C_F , you can neglect its effect. Finally, the resulting equivalent circuit is shown in [Figure 186](#). The increase in total capacitance draws a higher current from the IDAC achieving a higher change in raw count for a finger touch. Thus, in this condition, you get a higher sensitivity, which means that you will get a higher signal for a finger touch.

7 Design considerations

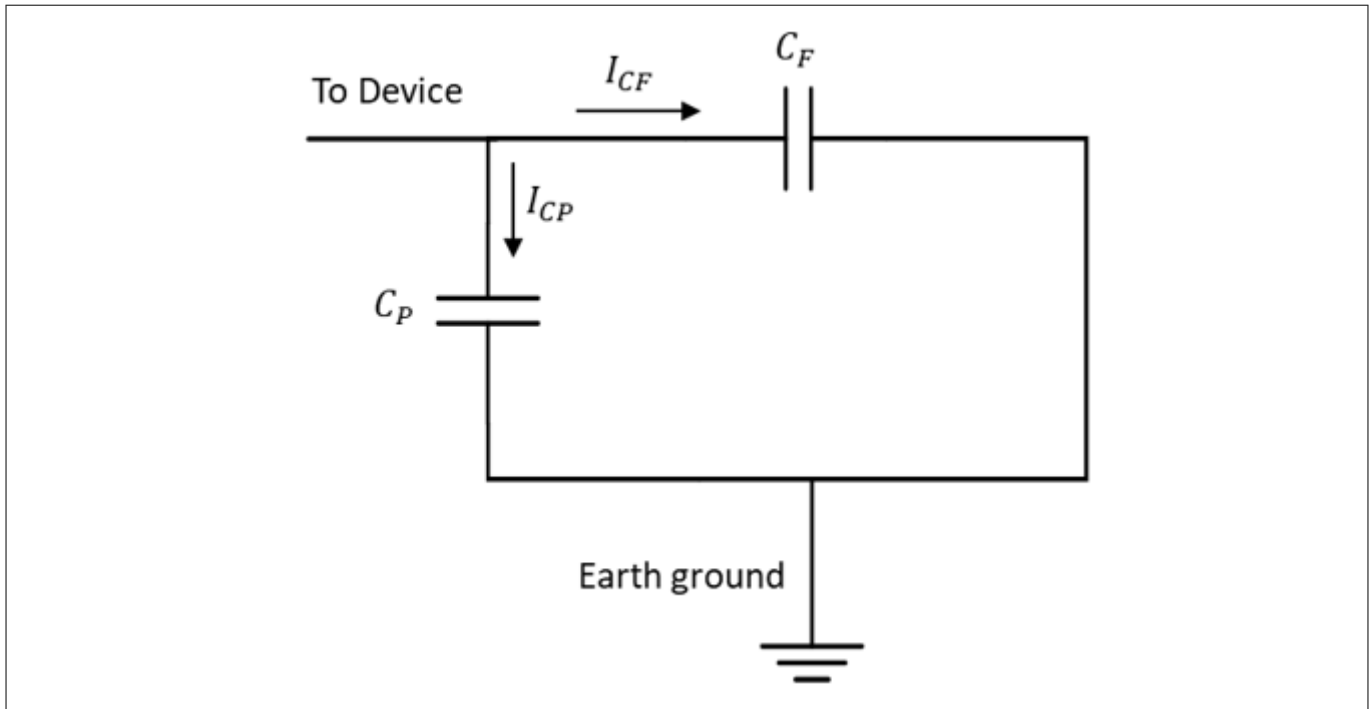

Figure 186 Equivalent circuit of the CSD sensor for mains-powered application

7.6.2.2 Battery-powered application

In battery-powered portable applications, device ground and earth ground are lightly coupled, thus C_{GE} is small. The resulting equivalent circuit is shown in Figure 187. Thus, in this condition, you get a lower sensitivity; that means you will get a lower signal for a finger touch, which is due to a decrease in capacitance seen at the device.

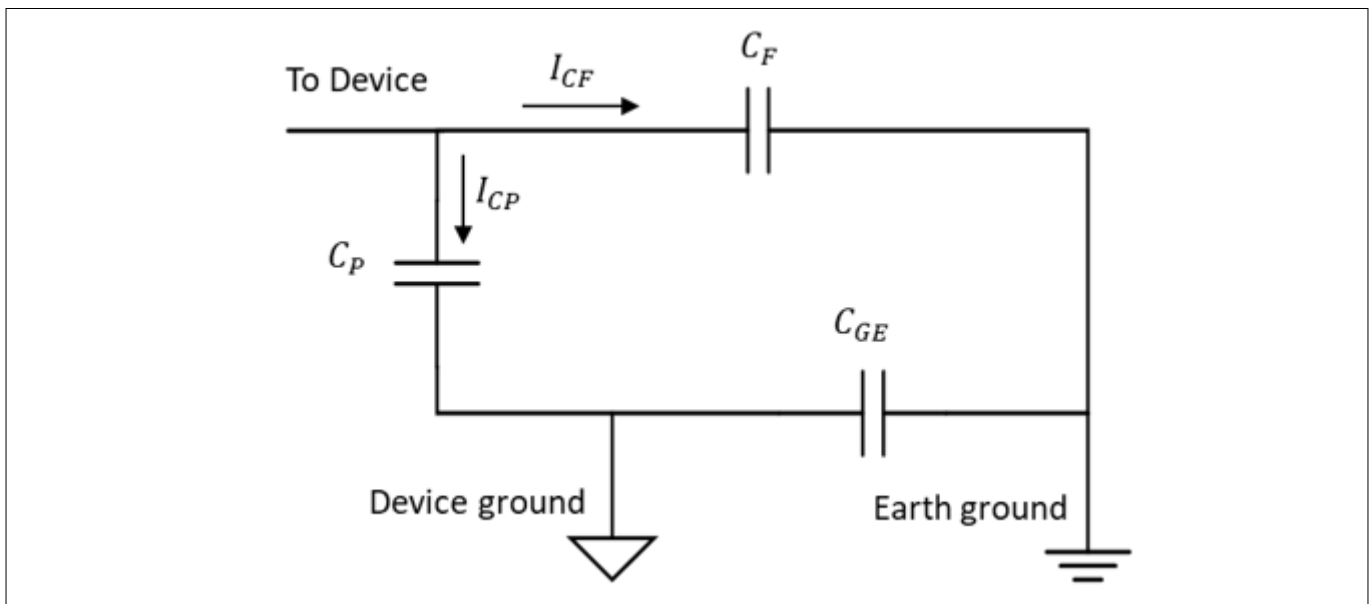

Figure 187 Equivalent circuit of the CSD for battery-powered application

Following are the recommendations for a CSD system design in a portable application powered by a battery:

8 CAPSENSE™ Plus

1. Add a large ground plane to the system. The ground plane should be away from the sensing element such that it does not increase the parasitic capacitance of the sensor. Follow the best practices for the [PCB layout guidelines](#) described in this chapter
2. Use a driven shield to improve the sensitivity of portable devices. Refer to the [Layout guidelines for shield electrode](#) for more details
3. Reduce the thickness of the overlay material or use an overlay with better dielectric value to improve sensitivity
4. Tune the CAPSENSE™ system with powering it by a battery source

8 CAPSENSE™ Plus

PSoC™ 4 can perform many additional functions along with CAPSENSE™. The wide variety of features offered by this device allows you to integrate various system functions in a single chip, as [Figure 188](#) shows. Such applications are known as CAPSENSE™ Plus applications.

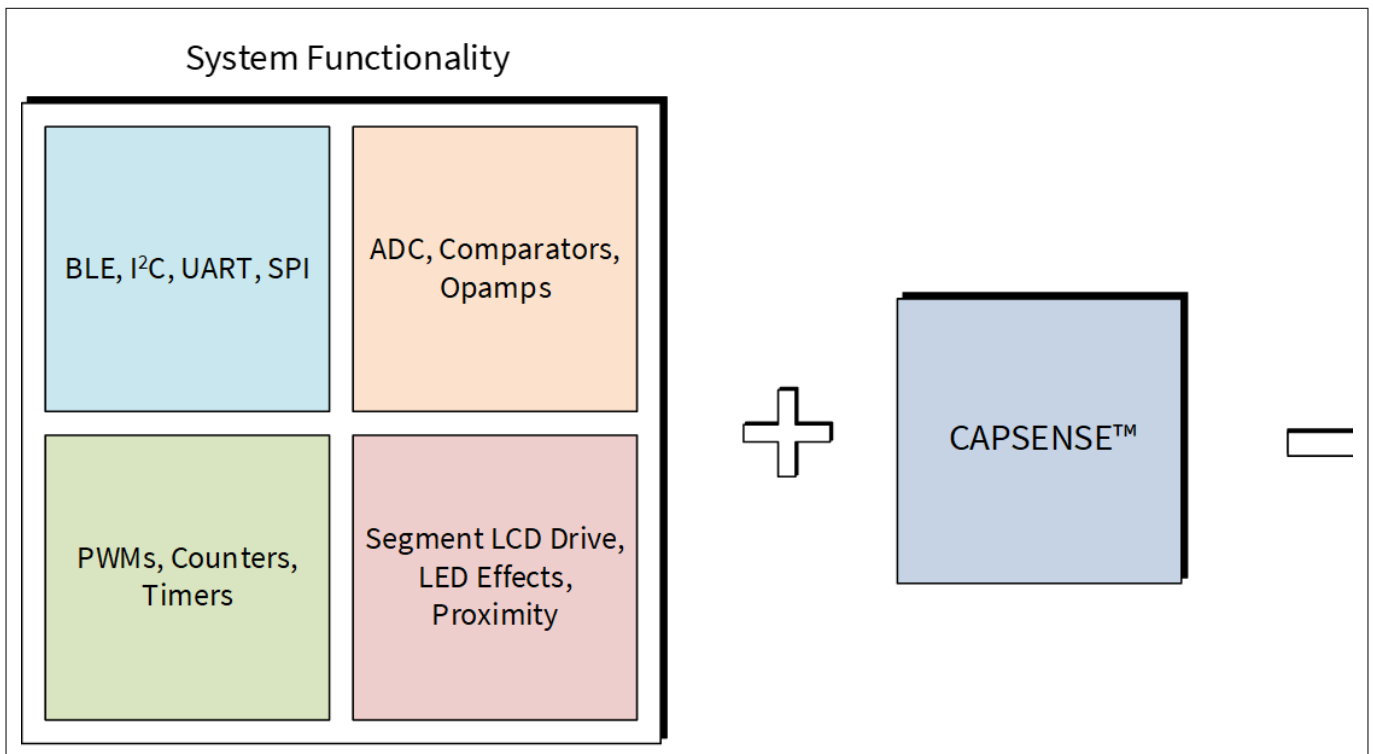

Figure 188 CAPSENSE™ Plus

The additional features available in a PSoC™ 4 device include:

- Communication: Bluetooth® LE, I²C, UART, SPI, CAN, and LIN
- Analog functions: ADC, comparators, and opamps
- Digital functions: PWMs, counters, timers, and UDBs
- Segment LCD drive
- Bootloaders
- Different power modes: Active, sleep, deep sleep, hibernate, and stop

While using above mentioned additional features, it is recommended to configure it in sinking mode as applicable.

For more information on PSoC™ 4, see [AN79953 - Getting started with PSoC™ 4](#), or [AN91267 - Getting started with PSoC™ 4 Bluetooth® LE](#).

8 CAPSENSE™ Plus

The flexibility of the PSoC™ 4 and the unique PSoC™ Creator IDE allow you to quickly make changes to your design, which accelerates time-to-market. Integrating other system functions significantly reduces overall system cost. Table 45 shows a list of example applications, where using CAPSENSE™ Plus can result in significant cost savings.

Table 45 Examples of CAPSENSE™ Plus

Application	CAPSENSE™	Opamp	ADC	Comp	PWM, Counter, Timer, UDBs	Comm(Bluetooth®, I2C, SPI, UART)	LCD drive	GPIOs
Heart rate monitor (wrist band)	User interface: buttons, linear sliders	TIA, Buffer	Heart Rate Measurement, Battery voltage measurement		LED Driving	Bluetooth® LE	Segment LCD	LED indication
LED bulb	User interface: buttons, radial sliders	Amplifier	LED current measurement	Short circuit protection	LED color control (PrISM*)	Bluetooth® LE		LED indication
Washing machine	User interface: buttons, radial sliders		Temperature sensor	Water level monitor	Buzzer, FOC** motor control	I ² C LCD display, UART network interface	Segment LCD	LED indication
Water heater	User interface: buttons, linear sliders		Temperature sensor, water flux sensor	Water level monitor	Buzzer	I ² C LCD display, UART Network Interface	Segment LCD	LED indication
IR remote controllers	User interface: buttons, linear and radial sliders, touchpads				Manchester encoder			LED indication
Induction cookers	User interface: buttons, linear sliders		Temperature sensor				Segment LCD	LED indication

(table continues...)

8 CAPSENSE™ Plus

Table 45 (continued) Examples of CAPSENSE™ Plus

Application	CAPSENSE™	Opamp	ADC	Comp	PWM, Counter, Timer, UDBs	Comm(Bluetooth®, LE, I2C, SPI, UART)	LCD drive	GPIOs
Motor control systems	User interface: buttons, linear sliders				BLDC*** and FOC motor control			LED indication
Gaming/simulation controllers	User interface: buttons, touchpads		Reading analog joysticks			I ² C/SPI/UART communication interface	Segment LCD	LED indication
Thermal printers	User interface: buttons		Overheat protection, paper sensor		Stepper motor control	SPI communication interface		LED indication

* PrISM = Precision illumination signal modulation

** FOC = Field oriented control

*** BLDC = Brushless DC motor

Figure 189 shows a general block diagram of a CAPSENSE™ Plus application, such as an induction cooker or a microwave oven.

8 CAPSENSE™ Plus

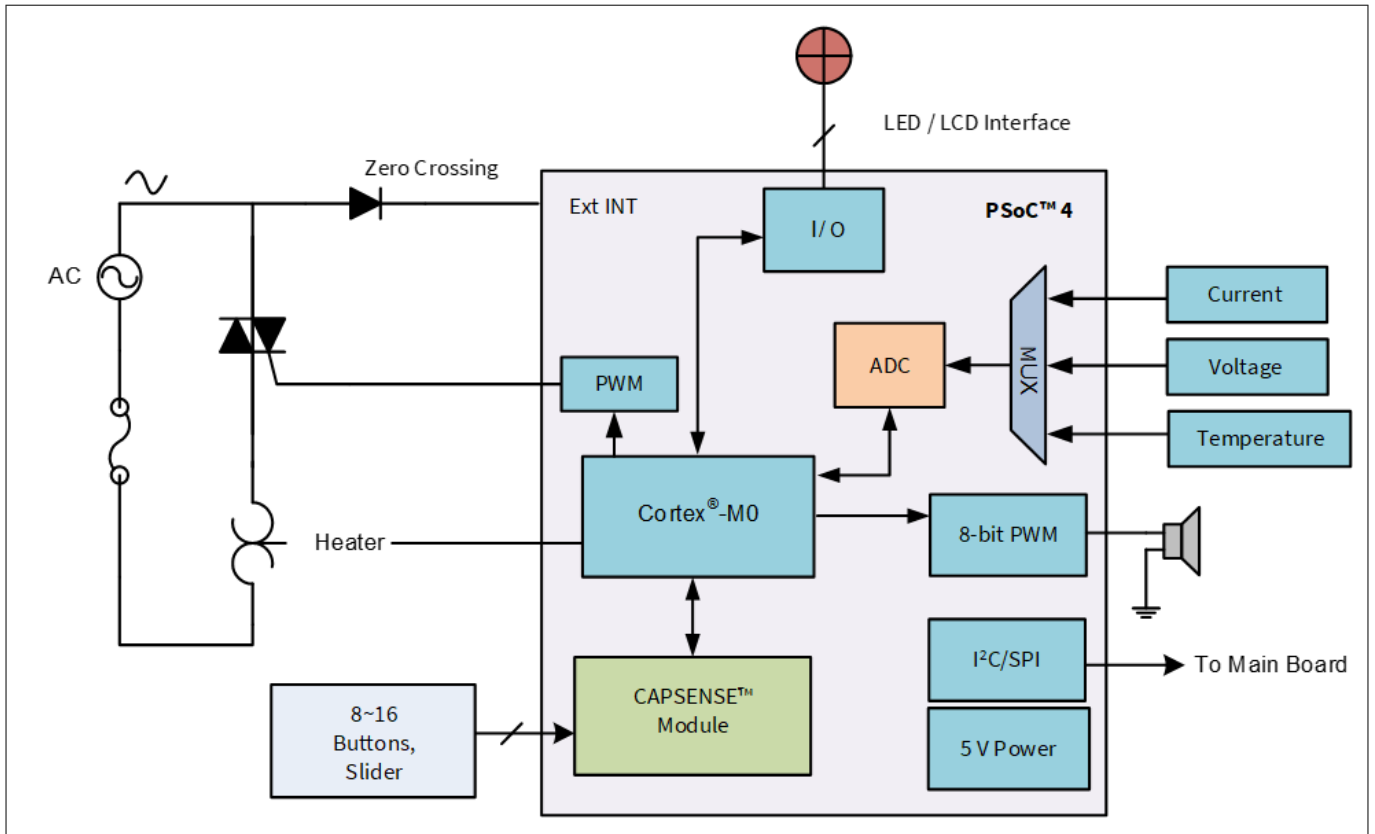

Figure 189 CAPSENSE™ Plus system with PSoC™ 4

In this application, the 12-bit 1 Msps SAR ADC in the PSoC™ 4 detects over-current, overvoltage, and high temperature conditions. The PWM output drives the speaker for status and alarm tones. Another PWM controls the heating element in the system. The CAPSENSE™ buttons and slider constitute the user interface. PSoC™ 4 can also drive a segment LCD for visual outputs. PSoC™ 4 has a serial communication block that can connect to the main board of the system.

Figure 190 shows the application-level block diagram of a fitness tracker based on PSoC™ 6 MCU with Bluetooth® LE Connectivity. The device provides a one-chip solution and includes features like activity monitoring, environment monitoring, CAPSENSE™ for user interface, Bluetooth® LE connectivity, and so on. For more information on PSoC™ 6 MCU, see [AN210781 – Getting started with PSoC™ 6 MCU with Bluetooth® LE connectivity](#).

8 CAPSENSE™ Plus

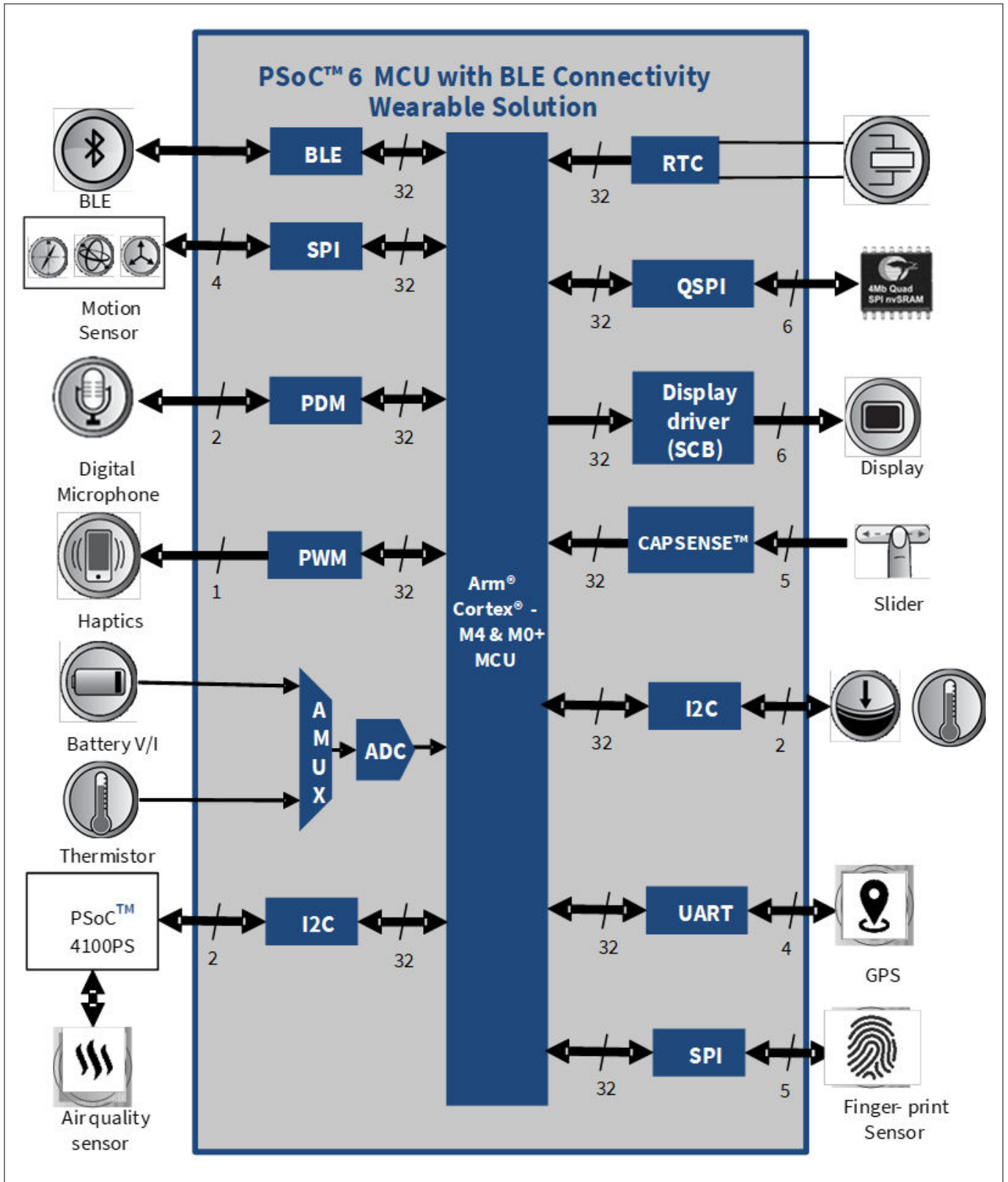

Figure 190 Fitness tracker application with PSoC™ 6 MCU with Bluetooth® LE connectivity block diagram

9 Resources

9 Resources

9.1 Website

Visit the [Getting started with PSoC™ 4](#), [Getting started with PSoC™ 4 Bluetooth® LE](#), [Getting started with PSoC™ 6 MCU](#), and [Getting started with PSoC™ 6 MCU with Bluetooth® LE connectivity](#) website to understand the PSoC™ 4, PSoC™ 6 MCU with Bluetooth® LE connectivity.

9.2 Device datasheet

- [PSoC™ 4 datasheet](#)
- [PSoC™ 4 Bluetooth® LE datasheet](#)
- [PSoC™ 6 MCU devices](#)

9.3 Component datasheet/middleware document

- [PSoC™ 4 Capacitive Sensing](#)
- [PSoC™ 6 capacitive sensing](#)
- [CAPSENSE™ middleware library](#)
- [ModusToolbox™ CAPSENSE™ configurator guide](#)

9.4 Technical reference manual

The [PSoC™ 4 Technical reference manual \(TRM\)](#) and [PSoC™ 6 Technical reference manual \(TRM\)](#) provide quick and easy access to information on PSoC™ 4 and PSoC™ 6 architecture including top-level architectural diagrams, register summaries, and timing diagrams.

9.5 Development kits

[Table 7](#) lists Infineon® development kits that support PSoC™ 4 and PSoC™ 6 CAPSENSE™.

9.6 PSoC™ Creator

PSoC™ Creator is a state-of-the-art, easy-to-use integrated development environment. See the [PSoC™ Creator home page](#).

9.7 ModusToolbox™

ModusToolbox™ software suite is used for the development of PSoC™ 4 and PSoC™ 6 based CAPSENSE™ applications. You can download the ModusToolbox™ software [here](#). The related documents are as follows:

- [ModusToolbox™ release notes](#)
- [ModusToolbox™ install guide](#)
- [ModusToolbox™ user guide](#)
- [ModusToolbox™ quick start guide](#)
- [ModusToolbox™ software training](#)
- [ModusToolbox™ CAPSENSE™ configurator](#)
- [ModusToolbox™ CAPSENSE™ tuner](#)

9 Resources

- [ModusToolbox™ device configurator](#)
- [ModusToolbox™ SmartIO configurator](#)
- [PSoC™ Creator to ModusToolbox™](#)
- [ModusToolbox™ command line](#)

9.8 Application notes and design guides

° A large collection of application notes are available to get your design up and running fast. See [PSoC™ 4 application notes](#), [PSoC™ 4 Bluetooth® LE application notes](#), [CAPSENSE™ application notes and design guides](#).

Following is the list of CAPSENSE™ specific applications notes:

Design guide for PSoC™ 3 and PSoC™ 5LP devices

- [PSoC™ 3 and PSoC™ 5LP CAPSENSE™ design guide](#)

Design guides for the CAPSENSE™ Express family

- [CY8CMBR3XXX CAPSENSE™ design guide](#)
- [CY8CMBR2110 CAPSENSE™ design guide](#)
- [CY8CMBR2016 CAPSENSE™ design guide](#)
- [CY8CMBR2010 CAPSENSE™ design guide](#)
- [CY8CMBR2044 CAPSENSE™ design guide](#)
- [CAPSENSE™ Express™: CY8C201XX application notes](#)

Design guides for PSoC™ 1 devices

- [CY8C20XX7/S design guide](#)
- [CY8C20XX6A/H CAPSENSE™ design guide](#)
- [CY8C21X34/B CAPSENSE™ design guide](#)
- [CY8C20X34 CAPSENSE™ design guide](#)

Getting started application note

- [AN79953 - Getting started with PSoC™ 4](#)
- [AN210781 – Getting started with PSoC™ 6 MCU with Bluetooth® LE connectivity](#)
- [AN221774 – Getting started with PSoC™ 6 MCU](#)

9.9 Design support

- [Knowledge base articles](#) – Browse technical articles by product family or perform a search on CAPSENSE™ topics
- [White papers](#) – Learn about advanced capacitive-touch interface topics
- [Infineon developer community](#) – Connect with the technical community and exchange information
- [Video library](#) – Quickly get up to speed with tutorial videos
- [Quality and reliability](#) – We are committed to complete customer satisfaction. At our Quality website, you can find reliability and product qualification reports
- <https://www.infineon.com/cms/en/about-infineon/company/contacts/support/> – Submit your design for review by creating a support case. You need to register and login at the website to be able to contact [technical support](#). It is recommended to use PDF prints for the schematic and Gerber files with layer information for the layout

Glossary

Glossary

AMUXBUS

Analog multiplexer bus available inside PSoC™ that helps to connect I/O pins with multiple internal analog signals.

Baseline

A value resulting from a firmware algorithm that estimates a trend in the Raw Count when there is no human finger present on the sensor. The Baseline is less sensitive to sudden changes in the Raw Count and provides a reference point for computing the Difference Count.

Button or button widget

A widget with an associated sensor that can report the active or inactive state (that is, only two states) of the sensor. For example, it can detect the touch or no-touch state of a finger on the sensor.

Capacitive sensor

A conductor and substrate, such as a copper button on a printed circuit board (PCB), which reacts to a touch or an approaching object with a change in capacitance.

CAPSENSE™

Infineon® Touch-sensing user interface solution. The industry's No. 1 solution in sales by 4x over No. 2.

CAPSENSE™ Mechanical Button Replacement (MBR)

Configurable solution to upgrade mechanical buttons to capacitive buttons, requires minimal engineering effort to configure the sensor parameters and does not require firmware development. These devices include the CY8CMBR3XXX and CY8CMBR2XXX families.

CAPSENSE™ signal

signal (CAPSENSE™ signal)

Difference Count is also called Signal. See Difference Count.

Centroid or Centroid Position

A number indicating the finger position on a slider within the range given by the Slider Resolution. This number is calculated by the CAPSENSE™ centroid calculation algorithm.

CMOD

Modulation capacitor (CMOD)

An external capacitor required for the operation of a CSD block in Self-Capacitance sensing mode.

Compensation IDAC

A programmable constant current source, which is used by CSD to compensate for excess sensor C_p . This IDAC is not controlled by the Sigma-Delta Modulator in the CSD block unlike the Modulation IDAC.

CP

Parasitic capacitance (CP)

Parasitic capacitance is the intrinsic capacitance of the sensor electrode contributed by PCB trace, sensor pad, vias, and air gap. It is unwanted because it reduces the sensitivity of CSD.

Glossary

CSD

CAPSENSE™ Sigma Delta

CAPSENSE™ Sigma Delta (CSD) is a patented method of performing self-capacitance (also called self-cap) measurements for capacitive sensing applications.

In CSD mode, the sensing system measures the self-capacitance of an electrode, and a change in the self-capacitance is detected to identify the presence or absence of a finger.

CSH

Shield tank capacitor (CSH)

An optional external capacitor (C_{SH} Tank Capacitor) used to enhance the drive capability of the CSD shield, when there is a large shield layer with high parasitic capacitance.

current-output digital-to-analog converter

IDAC (current-output digital-to-analog converter)

Programmable constant current source available inside PSoC™, used for CAPSENSE™ and ADC operations.

Debounce

A parameter that defines the number of consecutive scan samples for which the touch should be present for it to become valid. This parameter helps to reject spurious touch signals.

A finger touch is reported only if the Difference Count is greater than Finger Threshold + Hysteresis for a consecutive Debounce number of scan samples.

Difference count

The difference between Raw Count and Baseline. If the difference is negative, or if it is below Noise Threshold, the Difference Count is always set to zero.

Driven-shield

A technique used by CSD for enabling liquid tolerance in which the Shield Electrode is driven by a signal that is equal to the sensor switching signal in phase and amplitude.

Electrode

A conductive material such as a pad or a layer on PCB, ITO, or FPCB. The electrode is connected to a port pin on a CAPSENSE™ device and is used as a CAPSENSE™ sensor or to drive specific signals associated with CAPSENSE™ functionality.

Finger threshold

A parameter used with Hysteresis to determine the state of the sensor. Sensor state is reported ON if the Difference Count is higher than Finger Threshold + Hysteresis, and it is reported OFF if the Difference Count is below Finger Threshold – Hysteresis.

Ganged sensors

The method of connecting multiple sensors together and scanning them as a single sensor. Used for increasing the sensor area for proximity sensing and to reduce power consumption.

To reduce power when the system is in low-power mode, all the sensors can be ganged together and scanned as a single sensor taking less time instead of scanning all the sensors individually. When you touch any of the sensors, the system can transition into active mode where it scans all the sensors individually to detect which sensor is activated.

PSoC™ supports sensor-ganging in firmware, that is, multiple sensors can be connected simultaneously to AMUXBUS for scanning.

Glossary

Gesture

Gesture is an action, such as swiping and pinch-zoom, performed by the user. CAPSENSE™ has a gesture detection feature that identifies the different gestures based on predefined touch patterns. In the CAPSENSE™ Component, the Gesture feature is supported only by the Touchpad Widget.

Guard sensor

Copper trace that surrounds all the sensors on the PCB, similar to a button sensor and is used to detect a liquid stream. When the Guard Sensor is triggered, firmware can disable scanning of all other sensors to prevent false touches.

Hatch fill or hatch ground or hatched ground

While designing a PCB for capacitive sensing, a grounded copper plane should be placed surrounding the sensors for good noise immunity. But a solid ground increases the parasitic capacitance of the sensor which is not desired. Therefore, the ground should be filled in a special hatch pattern. A hatch pattern has closely-placed, crisscrossed lines looking like a mesh and the line width and the spacing between two lines determine the fill percentage. In case of liquid tolerance, this hatch fill referred as a shield electrode is driven with a shield signal instead of ground.

Hysteresis

A parameter used to prevent the sensor status output from random toggling due to system noise, used in conjunction with the Finger Threshold to determine the sensor state.

Linear slider

A widget consisting of more than one sensor arranged in a specific linear fashion to detect the physical position (in single axis) of a finger.

Liquid tolerance

The ability of a capacitive sensing system to work reliably in the presence of liquid droplets, streaming liquids or mist.

Low baseline reset

A parameter that represents the maximum number of scan samples where the Raw Count is abnormally below the Negative Noise Threshold. If the Low Baseline Reset value is exceeded, the Baseline is reset to the current Raw Count.

Manual-tuning

The manual process of setting (or tuning) the CAPSENSE™ parameters.

Matrix buttons

A widget consisting of more than two sensors arranged in a matrix fashion, used to detect the presence or absence of a human finger (a touch) on the intersections of vertically and horizontally arranged sensors.

If M is the number of sensors on the horizontal axis and N is the number of sensors on the vertical axis, the Matrix Buttons Widget can monitor a total of M x N intersections using ONLY M + N port pins.

When using the CSD sensing method (self-capacitance), this Widget can detect a valid touch on only one intersection position at a time.

Modulation IDAC

Modulation IDAC is a programmable constant current source, whose output is controlled (ON/OFF) by the sigma-delta modulator output in a CSD block to maintain the AMUXBUS voltage at V_{REF} . The average current supplied by this IDAC is equal to the average current drawn out by the sensor capacitor.

Glossary

Modulator clock

A clock source that is used to sample the modulator output from a CSD block during a sensor scan. This clock is also fed to the Raw Count counter. The scan time (excluding pre and post processing times) is given by $(2^N - 1) / \text{Modulator Clock Frequency}$, where N is the Scan Resolution.

MSC

Multi sense converter (MSC)

The multi sense converter is the analog to digital converter used in Fifth-Generation CAPSENSE™ technology also known as Ratiometric sensing technology.

Mutual-capacitance

Capacitance associated with an electrode (say Tx) with respect to another electrode (say Rx) is known as mutual-capacitance.

Negative noise threshold

A threshold used to differentiate usual noise from the spurious signals appearing in negative direction. This parameter is used in conjunction with the Low Baseline Reset parameter.

Baseline is updated to track the change in the Raw Count as long as the Raw Count stays within Negative Noise Threshold, that is, the difference between Baseline and Raw count (Baseline – Raw count) is less than Negative Noise Threshold.

Scenarios that may trigger such spurious signals in a negative direction include: a finger on the sensor on power-up, removal of a metal object placed near the sensor, removing a liquid-tolerant CAPSENSE™-enabled product from the water; and other sudden environmental changes.

Noise threshold

A parameter used to differentiate signal from noise for a sensor. If Raw Count – Baseline is greater than Noise Threshold, it indicates a likely valid signal. If the difference is less than Noise Threshold, Raw Count contains nothing but noise.

Noise

CAPSENSE™ noise (Noise)

The variation in the Raw Count when a sensor is in the OFF state (no touch), measured as peak-to-peak counts.

Overlay

A non-conductive material, such as plastic and glass, which covers the capacitive sensors and acts as a touch-surface. The PCB with the sensors is directly placed under the overlay or is connected through springs. The casing for a product often becomes the overlay.

Proximity sensor

A sensor that can detect the presence of nearby objects without any physical contact.

Radial slider

A widget consisting of more than one sensor arranged in a specific circular fashion to detect the physical position of a finger.

Raw count

The unprocessed digital count output of the CAPSENSE™ hardware block that represents the physical capacitance of the sensor.

Refresh interval

The time between two consecutive scans of a sensor.

Glossary

Scan resolution

Resolution (in bits) of the Raw Count produced by the CSD block.

Scan time

Time taken for completing the scan of a sensor.

Self-capacitance

The capacitance associated with an electrode with respect to circuit ground.

Sense clock

A clock source used to implement a switched-capacitor front-end for the CSD sensing method.

Sensitivity

The change in Raw Count corresponding to the change in sensor capacitance, expressed in counts/pF. Sensitivity of a sensor is dependent on the board layout, overlay properties, sensing method, and tuning parameters.

Sensor

See [Capacitive sensor](#).

Sensor auto reset

A setting to prevent a sensor from reporting false touch status indefinitely due to system failure, or when a metal object is continuously present near the sensor.

When Sensor Auto Reset is enabled, the Baseline is always updated even if the Difference Count is greater than the Noise Threshold. This prevents the sensor from reporting the ON status for an indefinite period of time. When Sensor Auto Reset is disabled, the Baseline is updated only when the Difference Count is less than the Noise Threshold.

Sensor ganging

See [Ganged sensors](#).

Shield electrode

Copper fill around sensors to prevent false touches due to the presence of water or other liquids. Shield Electrode is driven by the shield signal output from the CSD block. See [Driven-shield](#).

Slider resolution

A parameter indicating the total number of finger positions to be resolved on a slider.

SmartSense™ auto-tuning

A CAPSENSE™ algorithm that automatically sets sensing parameters for optimal performance after the design phase and continuously compensates for system, manufacturing, and environmental changes.

SNR

Signal-to-noise ratio

The ratio of the sensor signal, when touched, to the noise signal of an untouched sensor.

Touchpad

A Widget consisting of multiple sensors arranged in a specific horizontal and vertical fashion to detect the X and Y position of a touch.

Trackpad

See [Touchpad](#).

Glossary

Tuning

The process of finding the optimum values for various hardware and software or threshold parameters required for CAPSENSE™ operation.

VREF

Programmable reference voltage block available inside PSoC™ used for CAPSENSE™ and ADC operation.

Widget

A user-interface element in the CAPSENSE™ Component that consists of one sensor or a group of similar sensors. Button, proximity sensor, linear slider, radial slider, matrix buttons, and touchpad are the supported widgets.

Revision history

Revision history

Document version	Date of release	Description of changes
2013-04-19	**	New Design Guide.
2013-07-29	*A	Added dual IDAC support. Updated some schematics in chapter 6. Other minor changes to chapters 3, 5, and 6.
2013-11-13	*B	Added support of CY8C4000 devices. Minor fixes throughout the document.
2014-02-24	*C	Updated the table of device features. Changed IDAC names to sync with new PSoC™ Creator Component terms. Added a schematic checklist. Changed screenshots to match the new Component version.
2014-02-27	*D	Updated Table 1-1 per PSoC™ 4000 datasheet.
2014-03-20	*E	Added firmware design considerations to Chapter 6. Added power supply layout and schematic considerations to Chapter 6. Updated the IMO range for PSoC™ 4000
2014-04-15	*F	Updated to support PSoC™ 4000 and PSoC™ Creator 3.0 SP1.
2014-08-29	*G	Added Reference to Getting started with CAPSENSE™ in Proximity (three-dimensional) Renamed Chapter 2.5 to Liquid tolerance and re-wrote this section. Updated the recommendations for Shield drive that is Csh_tank precharge and C _{MOD} precharge in Chapter 3.2.7 CAPSENSE™ CSD shielding . Added recommendation for setting “API resolution” in Chapter Added guidelines on how to select value of “Sensitivity” parameter in Chapter Updated recommended values of threshold and hysteresis parameters in Chapter Manual tuning trade-offs Added Section Manual Tuning Slider Example. Updated maximum overlay thickness value for sliders in Table 29 . Added guideline on maximum thickness for overlays of materials other than acrylic in Chapter 7.3.2 Overlay thickness . Re-wrote Chapter Slider design . Added recommendations on DC loads in Chapter 7.4.5 Renamed and rewrote Chapter 7.4.12 to Layout guidelines for liquid tolerance . Added Chapter 7.4.13.1 External capacitors pin selection . Updated slider related recommendations in Layout rule Updated Electromagnetic compatibility (EMC) considerations , added extensive data on hardware and firmware considerations.
2014-12-19	*H	Added information for the PSoC™ 4 Bluetooth® LE family of devices. Added information for the PSoC™ 6 Bluetooth® LE family of devices. Updated ground and power layout guidelines in Chapter 7.4.10 and Chapter 7.4.11 .
2015-01-21	*I	Added information for PSoC™ 4200-M family of devices. Added footnote in chapter Slider . Added GPIO source/sink current limit in Table 36 . Changed document title to PSoC™ 4 CAPSENSE™ Design Guide – AN85951

Revision history

Document version	Date of release	Description of changes
2015-06-02	*J	<p>Changed Document Title to “AN85951 – PSoC™ 4 CAPSENSE™ Design Guide”.</p> <p>Updated Design considerations</p> <p>Updated Preventing ESD discharge.</p> <p>Updated Figure 162.</p> <p>Updated Redirect.</p> <p>Replaced "Guard Ring" with "Ground Ring".</p>
2015-08-20	*K	<p>Added Table 3-1.</p> <p>Removed chapter 3.2.1 C_{MOD} Precharge.</p> <p>Added chapter CAPSENSE™ in PSoC™ 4xxxM/4xxxL-Series.</p> <p>Updated chapter Trace routing.</p> <p>Added reference of AN2397.</p> <p>Added recommendation for modulator clock divider in chapter Manual tuning trade-offs.</p> <p>Added Figure 159</p>
2015-09-16	*L	<p>Updated Chapter 1.1.</p> <p>Updated 11 Figure 1.</p> <p>Updated Table 7, Table 34, Table 35, Table 37.</p>
2016-01-19	*M	<p>Updated Introduction.</p> <p>Moved Signal-to-noise ratio (SNR) to Chapter 2.</p> <p>Updated Chapters PSoC™ 4 and PSoC™ 6 MCU and for CAPSENSE™ performance details.</p> <p>Added section to Chapter 4.</p> <p>Added Glossary.</p>
2016-02-23	*N	<p>Added information on mutual-capacitance sensing in PSoC™ 4 device series.</p> <p>Added information on CAPSENSE™ 3.0 changes.</p> <p>Added following sections:</p> <ul style="list-style-type: none"> • Mutual-capacitance sensing • CAPSENSE™ Architecture in PSoC 4 S-series <p>Updated following sections:</p> <ul style="list-style-type: none"> • Introduction • CAPSENSE™ • CAPSENSE™ design and development tools • CAPSENSE™ performance tuning
2016-03-04	*O	<p>Added PSoC™ Analog Coprocessor references.</p> <p>Updated External capacitors pin selection.</p> <p>Updated Development kits chapter.</p> <p>Updated document title.</p> <p>Updated Copyright notice.</p>
2016-06-14	*P	<p>Updated IDAC sinking mode recommendation.</p> <p>Updated template.</p>
2016-11-18	*Q	<p>Updated Recommended pins for external capacitors.</p>
2017-04-19	*R	<p>Updated logo and copyright.</p>

Revision history

Document version	Date of release	Description of changes
2017-09-22	*S	<p>Added references to PSoC™ 4100S Plus throughout the document.</p> <p>Updated Chapter 1.2 CAPSENSE™ features with PSoC™ 4100S Plus features.</p> <p>Updated PSoC™ 4 and PSoC™ 6 CAPSENSE™ development kits with CY8CKIT-149 PSoC™ 4100S Plus prototyping kit.</p> <p>Updated Chapter 9.8 Application notes and design guides with specific list of CAPSENSE™ Application Notes</p>
2018-01-18	*T	<p>Changed document title</p> <p>Added references to PSoC™ 6 MCU features throughout the document</p> <p>Updated CAPSENSE™ generations in PSoC™ 4 and PSoC™ 6 CAPSENSE™ generations in PSoC™ 4 and PSoC™ 6 with generalized architecture block diagram for CSD sensing.</p> <p>Added Gesture in CAPSENSE™ Gesture in CAPSENSE™.</p> <p>Updated Table 7, Table 17, Table 38.</p>
2018-02-28	*U	<p>Added references to PSoC™ 4100PS throughout the document.</p>
2018-11-08	*V	<p>Updated the entire document with references to CY8C62x8 and CY8C62xA devices.</p> <p>Updated the entire document with references to ModusToolbox™.</p> <p>Updated Table 7 with the information of PSoC™ 6 kits.</p> <p>Updated chapter Mutual-capacitance button design with the information of additional mutual cap key.</p> <p>Removed all references to PSoC™ Bluetooth® LE devices.</p>
2019-04-11	*W	<p>Updated SmartSense and Manual tuning with respect to the latest component.</p> <p>Removed details on different shield drive mode from CAPSENSE™ CSD</p> <p>Updated CAPSENSE™ CSX sensing</p> <ul style="list-style-type: none"> Updated figures in PSoC™ Creator SmartSense, and Gesture in CAPSENSE™ with respect to the latest component <p>Removed a table in External capacitors pin selection chapter</p> <p>Updated Table 3</p>
2020-01-07	*X	<p>Added Liquid tolerance for Mutual Capacitance Sensing section</p> <p>Removed Mutual Capacitance Button Design section</p> <p>Updated Table 3-2 and Table 3-3</p> <p>Updated CAPSENSE™ CSX Sensing Method</p> <p>Added ModusToolBox™ section in Chapter 4</p> <p>Updated SmartSense and Manual Tuning section with respect to the latest component.</p> <p>Updated Slider Tuning Guidelines section</p> <p>Added Tuning Shield Electrode section</p> <p>Updated Gesture chapter with gesture tuning guidelines</p> <p>Updated the Low Power design section</p> <p>Updated Sensor and Device placement section</p> <p>Updated Slider Design section</p> <p>Added Effect of Grounding in CSX method and Effect of Grounding in CSD method section</p>

Revision history

Document version	Date of release	Description of changes
2020-03-18	*Y	Updated Sensor pin selection and chapters.
2020-10-08	*Z	<p>Added CAPSENSE™ configurator CAPSENSE™ configurator.</p> <p>Moved Tuning Shield Electrode section under Chapter 5.3.2 CSD sensing method (third- and fourth-generation).</p> <p>Added Chapter 5.3.7.12 I am observing a low CM for my CSX button.</p> <p>Added Chapter 7.4.3.2 Mutual-capacitance button design.</p> <p>Added additional layout guidelines in Chapter 7.4.5 Sensor and device placement.</p> <p>Added additional trace routing guidelines in Chapter 7.4.7 Trace routing.</p> <p>Added additional guard trace guidelines in Crosstalk Crosstalk .</p> <p>Added new Chapter 7.5 Noise in CAPSENSE™ system.</p> <p>Added a single line description on self cap buttons in Self-capacitance button Self-capacitance button .</p> <p>Moved ESD and Electromagnetic compatibility (EMC) considerations under Chapter 7.5.3 External noise.</p> <p>Moved Effect of grounding on CSX method and effect of grounding on CSD method under Effect of grounding.</p>
2021-10-01	AA	<p>Updated to IFX template.</p> <p>Updated CAPSENSE™ features with new Fifth-Generation CAPSENSE™ block and PSoC™ 4100S Max features.</p> <p>Update Table 2.</p> <p>Added new section CAPSENSE™ CSD-RM sensing method (fifth-generation) and CAPSENSE™ CSX-RM sensing method (fifth-generation).</p> <p>Added new section for features Autonomous scanning and Usage of multiple channels.</p> <p>Removed “5.3.2.4 Button widget example” and replaced with Button widget tuning.</p> <p>Added new chapter Touchpad widget tuning.</p> <p>Added new section for Fifth-generation CAPSENSE™ sensing method - CSD-RM sensing method (fifth-generation and fifth-generation low-power) and CSX-RM sensing method (fifth-generation and fifth-generation low-power).</p> <p>Updated Table 29, Table 37, and Table 38.</p> <p>Updated Copyright information.</p>
2022-07-21	AB	Template update
2022-12-20	AC	In the Table 2 , in the Feature column, updated "Noise floor (pk-pk)" to "Noise floor (rms)".
2023-08-04	AD	<p>Updated link references</p> <p>Deleted CSD Finger Detection Criteria</p> <p>Deleted CSX Finger Detection Criteria</p> <p>Added Synchronized scanning section</p> <p>Added CIC2 section</p> <p>Added the section title Advantages of fifth generation and fifth generation low-power</p>

Trademarks

All referenced product or service names and trademarks are the property of their respective owners.

Edition 2023-08-04

Published by

Infineon Technologies AG

81726 Munich, Germany

© 2023 Infineon Technologies AG

All Rights Reserved.

Do you have a question about any aspect of this document?

Email: erratum@infineon.com

Document reference

IFX-jaz1649247577419

Important notice

The information contained in this application note is given as a hint for the implementation of the product only and shall in no event be regarded as a description or warranty of a certain functionality, condition or quality of the product. Before implementation of the product, the recipient of this application note must verify any function and other technical information given herein in the real application. Infineon Technologies hereby disclaims any and all warranties and liabilities of any kind (including without limitation warranties of non-infringement of intellectual property rights of any third party) with respect to any and all information given in this application note.

The data contained in this document is exclusively intended for technically trained staff. It is the responsibility of customer's technical departments to evaluate the suitability of the product for the intended application and the completeness of the product information given in this document with respect to such application.

Warnings

Due to technical requirements products may contain dangerous substances. For information on the types in question please contact your nearest Infineon Technologies office.

Except as otherwise explicitly approved by Infineon Technologies in a written document signed by authorized representatives of Infineon Technologies, Infineon Technologies' products may not be used in any applications where a failure of the product or any consequences of the use thereof can reasonably be expected to result in personal injury.