

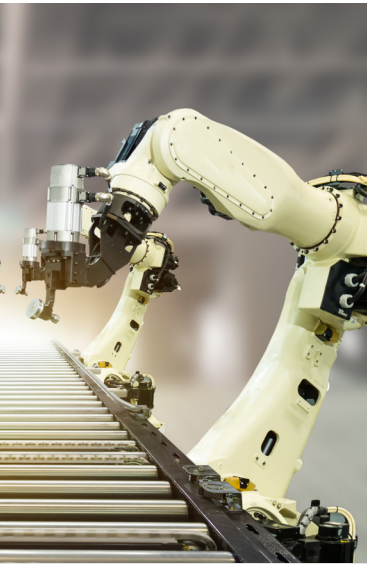

Go with gate drive  
optocoupler



# Isolation Technologies and Comparisons

## Contents

- 1 Isolation Technologies and Comparisons
- 2 Robust and reliable optical isolation technology
- 4 Leading gate drive solutions for industrial applications
- 6 Product Selection Trees
- 8 Driving SiC and GaN power semiconductors
- 10 Reference designs for SiC and GaN power semiconductors
- 12 Improve motor lifetime with slew rate control gate driver
- 16 Functional safety for motor drive
- 18 New product highlights
- 22 Product Selection



| Isolator / Coupler Types                   | Broadcom Optocoupler  | Magnetic Isolator  | Capacitive Isolator  |
|--|---|--|--|
| Isolation Construction                     |   |  |  |
| Insulation Material                        | <b>3 layers</b><br>(Silicone / Kapton / Silicone)   | <b>1 layer</b><br>(Polyimide)  | <b>1 layer</b><br>(Silicon Dioxide)  |
| Insulation Thickness                       | <b>0.08mm to 2mm</b>  | Up to -0.02mm for single coil; -0.04mm for double coil   | Up to -0.014mm for single cap; -0.028mm for double cap                           |
| Insulation Strength                        | <b>Very Good</b>  | Fair   | Weak   |
| Component Certification   Test Method      | <b>IEC-60747-5-5</b><br>(reinforced - passed min. 10kV surge)<br><b>Partial Discharge</b>                           | <b>IEC-60747-17</b><br>(basic or reinforced - passed min. 10kV surge)<br><b>Partial Discharge</b><br>Lifetime failure mechanism / predictions assessed only in type test |  |
| Lifetime and Reliability Failure Mechanism | <b>Partial Discharge</b><br>No lifetime failures - guaranteed by 100% PD test at final production test (VDE option) | <b>Space Charge Degradation</b><br>Allowable failure in time Reinforced < 1 ppm<br>Basic < 1,000 ppm   | <b>TDDB</b><br>Allowable failure in time Reinforced < 1 ppm<br>Basic < 1,000 ppm |
| Insulation Vulnerability                   | <b>Robust thick insulation</b> with proven track record   | Thin film insulation vulnerable to electrical and thermal stress. Insulation damage due to delamination causing early TDDB   |  |
| UL1577 V <sub>ISO</sub> Withstand Voltage  | <b>Double Protection</b><br>(Passed Type Test min. 20kV 50 discharges)  | Single Protection  | Single Protection  |
| EMI/EMC Susceptibility                     | <b>Very Good</b><br>(Faraday Shield implemented at detector side)   | Weak   | Fair   |

- ✓ Optocoupler is the dominant isolation technology in the industry
- ✓ Optical isolation is preferred choice for high voltage isolation and better noise immunity performance
- ✓ Optical isolation technology proven track record of more than 50 years
- ✗ Broadcom Isolation Products currently not supporting IEC60747-17
- ✗ IEC60747-17 specifies statistical failure rate
- ✗ IEC-60747-17 currently only recognizes Polyimide and Silicon Dioxide as the insulation materials



## Robust and reliable optical isolation technology enables high noise rejection and safety

### Optical Isolation Technology

Figure 2 shows the construction of a Broadcom optical isolator. An infrared LED on the primary side is used to transmit information across the multi-layer insulation barrier to a detector IC over the galvanically isolated secondary side.

The use of optical isolation technology allows for an optimum design tradeoff between low power consumption and separation distance.

The relatively large internal separation distance in turn is a key to (common mode) noise rejection and insulation capability in high voltage environments.

### Common Mode Transient Immunity (CMTI)

The internal separation and Faraday shield covering the detector IC reduces the coupling capacitance across the isolator. This low capacitance, combined with optical isolation technology provide leading industry CMTI performance of up to 150kV/ $\mu$ s.

Figure 2. Optical isolator construction

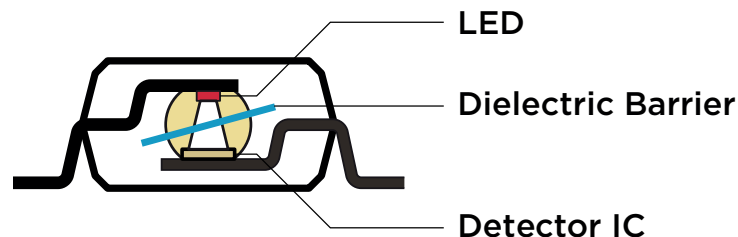

## Reinforced insulation suitable for failsafe design

### Robustness to Long Term High Voltage Stress

As isolators are often used in applications with specific electrical safety requirements, it is extremely important to ensure – by construction and testing - that the insulation capability of products do not degrade over time when subjected to high continuous or transient voltages.

The relevant aging mechanism used for the insulation construction in optical isolators, presented in this booklet is called **Partial Discharge**. All Broadcom gate drive optocouplers (or with VDE option) have 100% partial discharge testing at the rated working and transient voltages.

Other known aging mechanisms, such as space charge degradation (thin spin-on polyimides) or time dependent break down ( $\text{SiO}_2$ ) are not activated or applicable to Broadcom optically isolated products.

More information on safety and isolation technologies can be found in the Broadcom white paper “*Safety Considerations When Using Optocouplers and Alternative Isolators for Providing Protection Against Electrical Hazards*”, available at [www.broadcom.com](http://www.broadcom.com) under the Support, then Product Resources tab.

### Resistance to ESD and Other High Voltage Transients

One important aspect of an isolator is the transient voltage rejection, not only between inputs and ground but also between the two isolated grounds. The surge test for Broadcom optocouplers, measured across the isolation barrier is > 16kV.

### Reliability and Quality of LEDs

The LEDs used in Broadcom gate drive optocouplers are dimensioned so that they pose no limitation on the end product life time. The infrared LED technology used for optocouplers is a core competency for Broadcom that has been developed over 50 years. Broadcom continues to do R&D and LED production in house to maintain its technological leadership, reliability and quality.

Gate drive optocouplers, whose performance and reliability depend on quality LED technology, are available in industrial and automotive grade (125°C), and space/military grade (hermetic, 125°C) versions.

# Leading gate drive solutions for industrial applications

## Target Applications

- IGBT, SiC and GaN MOSFET gate drive
- AC and servo motor drives
- Renewable energy inverter and storage
- Robotics and factor automation
- Heating, ventilation and air conditioning
- Power supply

Broadcom optocouplers have been used in an array of isolation applications ranging from power supply and motor control circuits to data communications and digital logic interface circuits for more than 50 years.

The primary purpose of an optocoupler is to provide both electrical insulation and signal isolation. The popularity of Broadcom optocouplers is due to cost effective innovations in these areas.

In typical motor drive and renewable energy power conversion systems, there are several signals between the power devices and the microcontroller that need isolation and additional customized functions such as gate drive and current/voltage sensing. Broadcom's gate drive optocouplers provide low cost, high performance solutions for such applications.

## Highly integrated gate drive optocouplers

### Introduction

High performance motor drives require precision timing for turning on and off the power devices on the inverter while renewable energy inverter needs to be reliable and efficient when converting DC-link voltage to usable AC power output. The microcontroller that controls these functions needs to be isolated from the high voltage inverter.

Broadcom offers a variety of optocouplers that have built-in gate drive capability. These gate drive optocouplers come in wide range of output current from 0.4A to 12A, and selected parts with integrated protection features such as slew rate control, short circuit or over-current detection, functional safety reporting, active Miller clamp and under voltage lockout.

Beside protection features, Broadcom has also integrated DC-DC controller for floating power supply and LED driver to make design more compact and affordable.

Figure 1. Gate drive optocouplers in a three phase motor drive application

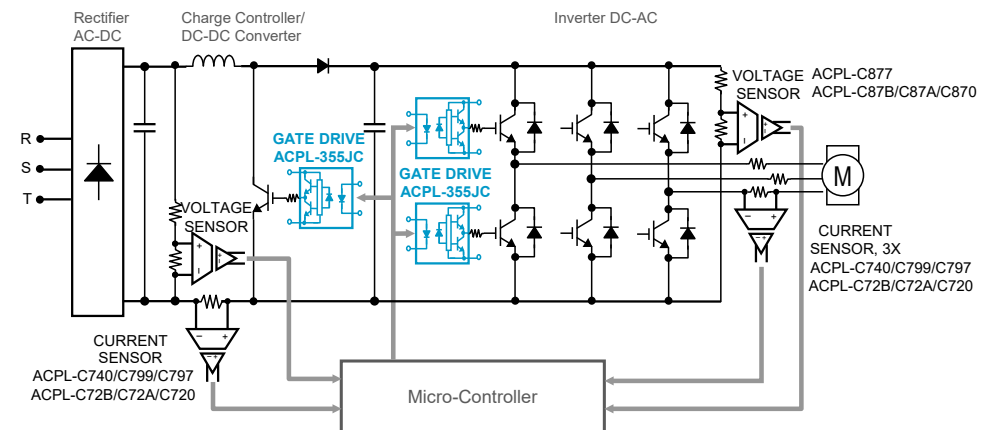

# GO with OPTO!

**BROADCOM® OPTOCOUPLEDERS**

50  
YEARS

# Product Selection Trees

## Highly Integrated Smart Gate Drive Optocoupler NPI Product Tree

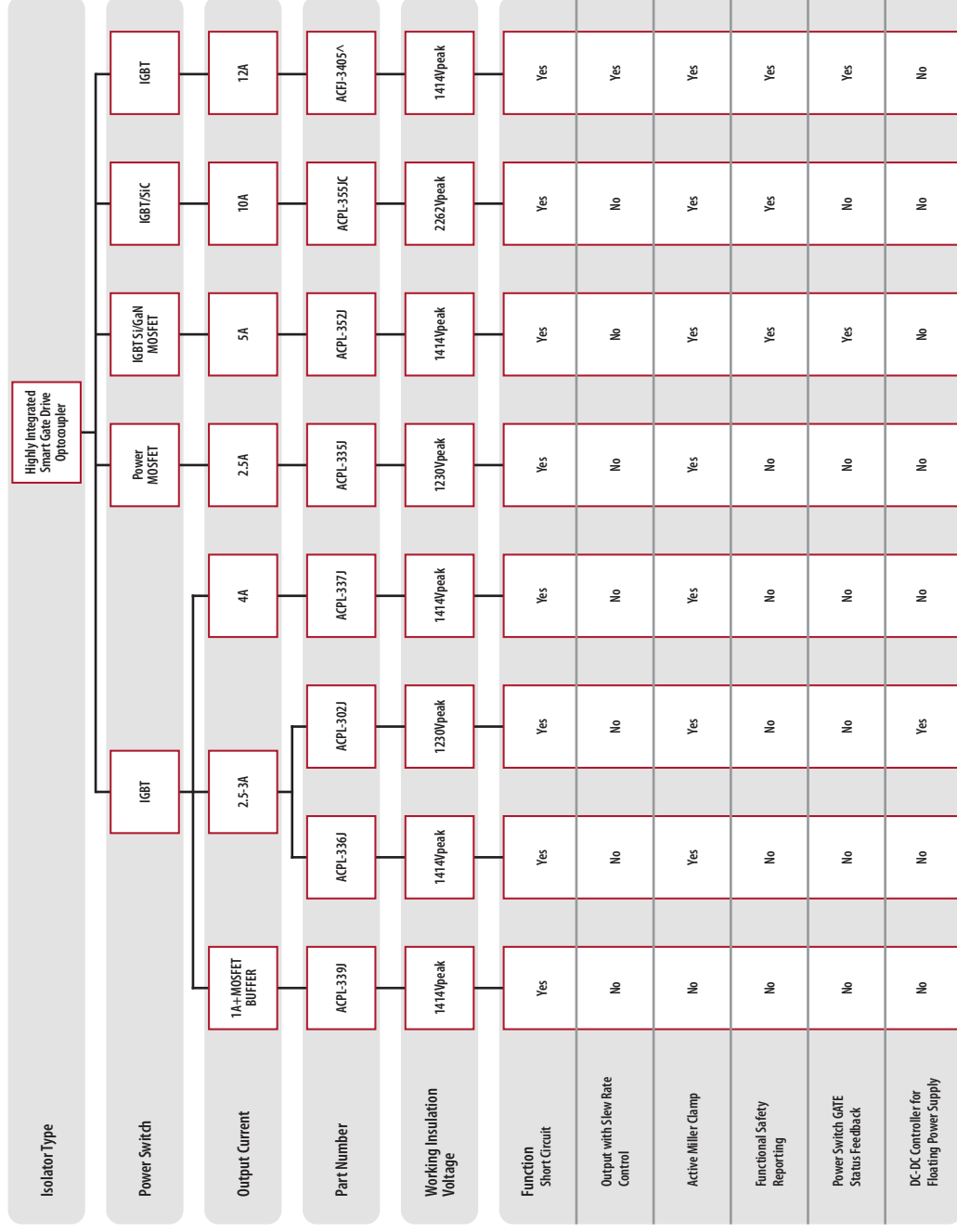

^Advance information subject to change

## Broadcom Gate Drive Optocouplers

### Basic Gate Drive Optocoupler NPI Product Tree

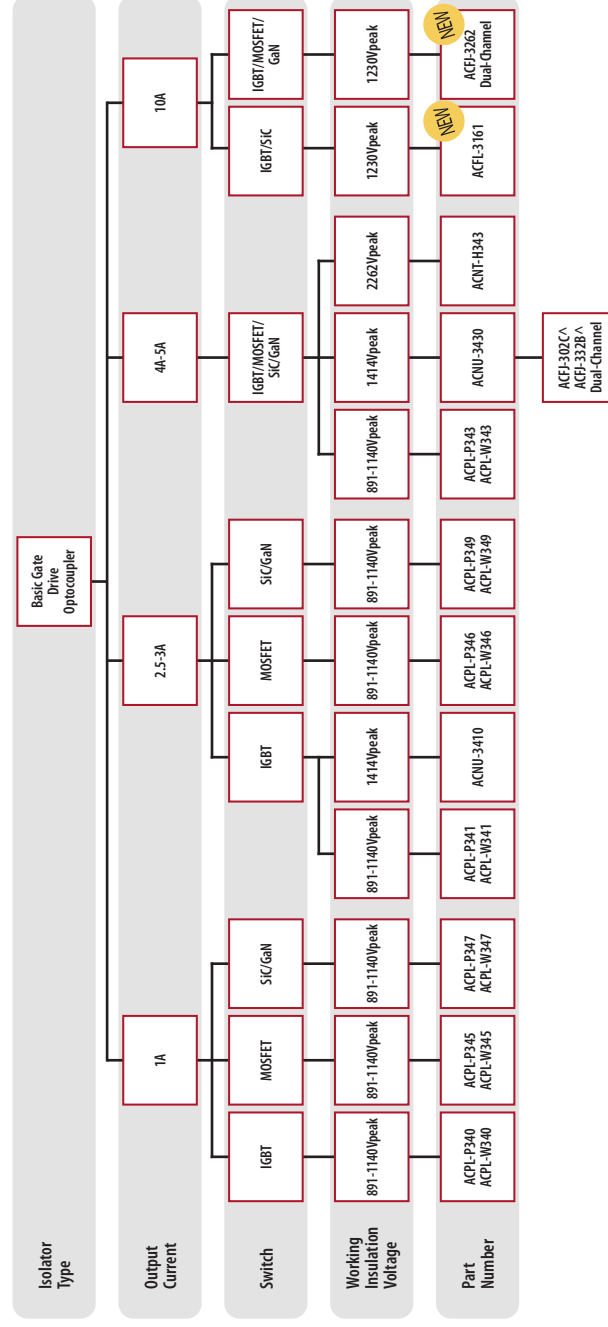

^Advance information subject to change



## Driving SiC and GaN power semiconductors

### The rise of SiC and GaN power semiconductors

SiC and GaN are now widely recognized as a reliable alternative to silicon IGBT. Their ability to increase overall system efficiency and switching speed can help reduce the overall system size and costs. Major suppliers are ramping up their production with packages and pinouts that can replace existing IGBTs easily. This drives the costs of SiC and GaN power semiconductors to a very competitive level, which is probably the most important factor that makes adoption take off.

### The standardization of SiC and GaN power semiconductors

SiC and GaN power semiconductors specifications have evolved to be easily driven and protected by gate drivers.

The first specification would be gate-source voltage,  $V_{GS}$ . The optimum  $V_{GS}$  for SiC FET operations has reduced from 20V to the same level as the  $V_{GE}$  of IGBTs, at 15 V. Likewise, the  $V_{GS}$  of GaN FET has increased from 4V to 10V, the same level as silicon power MOSFET. The difference in  $V_{GS}$  will require the output of gate driver to have different under voltage lockout(UVLO) threshold.

The second specification is the total gate charge,  $Q_G$ .  $Q_G$  of SiC and GaN FETs is more than 2 to 3 times smaller to their equivalent silicon counterparts. This allows them to switch quickly, reducing the switching losses and increasing the operating frequency. A lower  $Q_G$  also implies a lower gate current, which helps to eliminate a current buffer stage.

The third specification is the slew rate or  $dv/dt$  which measures how fast the SiC & GaN FETs switch from zero to the BUS voltage within the shortest time. Although fast switching is critical to reduce switching losses, the high  $dv/dt$  generated can be a nuisance and causes noise to the control. The ability for the gate driver to reject the  $dv/dt$  noise is specified by the common mode transient immunity (CMTI). SiC and GaN FETs are capable to switch 100 V/ns and requires a gate driver with CMTI rating of more than 100 kV/ $\mu$ s.

The last specification is the short circuit withstand time (SCWT). Silicon IGBTs in general have superior SCWTs to SiC or GaN FETs. Hence, any short circuit fault current in the SiC FET needs to be extinguished faster before the switch is destroyed. Typically, the rule of thumb is 1 to 3  $\mu$ s for SiC and GaN FETs, as compared to 5 to 10  $\mu$ s for IGBTs.

## Gate drive optocouplers for SiC and GaN power semiconductors

With the understandings of gate-source voltage, gate charge, slew rate and short circuit withstand time, table 1 shows the gate drive optocouplers and their specifications suitable for driving SiC or GaN power semiconductors. It is to note that these gate drivers can be used to drive the silicon counter parts of IGBT and power MOSFET.

Table 1. Power semiconductors and gate drive optocouplers

| Power Semiconductor  | Gate Drive Optocoupler | Under Voltage Lockout | Output Current (max.) | CMTI (kV/ $\mu$ s) | Features   |
|----------------------|------------------------|-----------------------|-----------------------|--------------------|--|
| SiC MOSFET IGBT      | ACPL-355JC             | 13V                   | 10A                   | 100                | DESAT sensing with adjustable blanking time for SCWT |
|                      | ACFL-3161              | 13V                   | 10A                   | 100                | Separate source and sink outputs                     |
|                      | ACFJ-302C              | 12V                   | 4A                    | 150                | Active Miller Clamp                                  |
| GaN FET Power MOSFET | ACFJ-3262              | 8V                    | 10A                   | 100                | Separate source and sink outputs                     |
|                      | ACFJ-332B              | 8V                    | 4A                    | 150                | Active Miller clamp                                  |

## Reference designs for SiC and GaN power semiconductors

Broadcom develops reference designs to help customers shorten design cycle and speed up time-to-market. Broadcom has partnered with key SiC and GaN FETs suppliers or our channel partners who have in depth system and product knowledge in their respective field, for most of the reference designs. The SiC and GaN FETs reference designs include schematics, layouts, BOMs and test results to demonstrate best engineering and industrial practices.

[www.broadcom.com/products/optocouplers/reference-designs](http://www.broadcom.com/products/optocouplers/reference-designs)

Figure 3. Reference designs for SiC and GaN power semiconductors

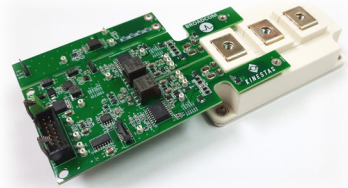

### ACPL-355JC Infineon

62mm SiC 1200/350A-500A Module

- FF2MR12KM1
- FF3MR12KM1
- FF6MR12KM1

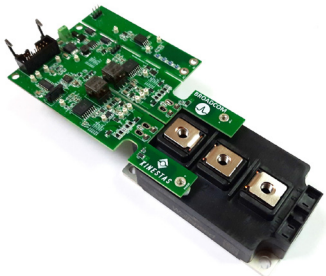

### ACPL-355JC Wolfspeed

62mm SiC 1200/300A-400A Module

- WAB300M12BM3
- WAB400M12BM3

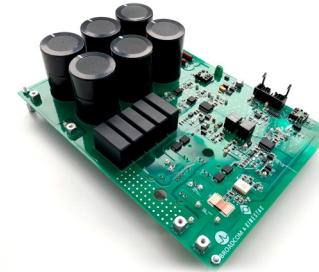

### ACPL-355JC Infineon

Half-Bridge 1200V SiC module

- FF23MR12W1M1\_B11
- FF11MR12W1M1\_B11



### ACPL-355JC Wolfspeed

FM3 Half-Bridge 1200V SiC module

- CAB011M12FM3
- CAB016M12FM3



### ACFL-3161

STM, Wolfspeed and Nexperia

TO247 1200V SiC Discreet

- SCTWA70N120G2V
- C3M002120K
- NSF080120L4AO

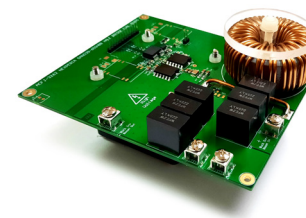

### ACFJ-3262 Nexperia

CCPAK 650V GaN Discreet

- GAN039-650NBB

# Improve motor lifetime with slew rate control gate driver

Figure 4. High dv/dt causes excessive overvoltage with long cable between drive and motor

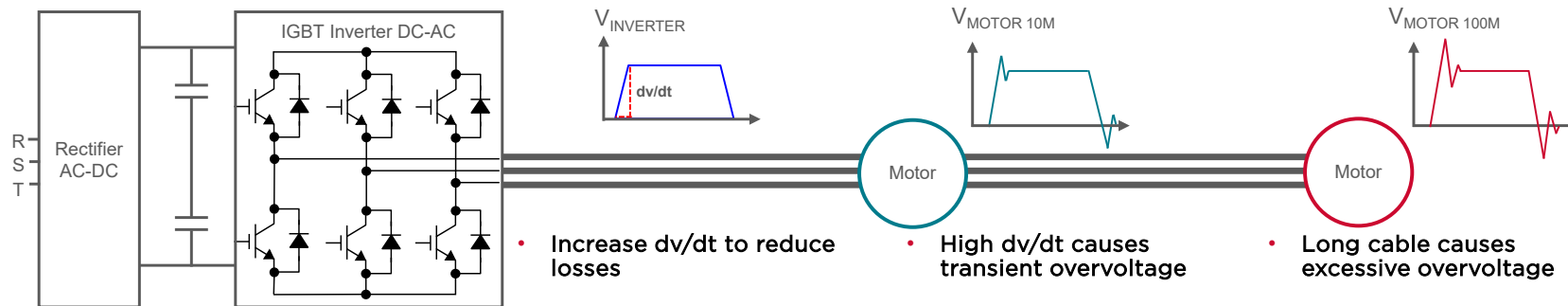

## Excessive overvoltage with long cable between drive and motor

Pulse-width modulation or PWM is a method of reducing the average power delivered by an electrical signal, by effectively converting analog to digital signals. To keep the losses in the inverter low, the switching times of the power semiconductors are kept as short as possible.

This results in the increase of slew rate or  $dv/dt$ , especially with the new generation of IGBTs. In many industrial applications, induction motor and inverter are placed at different locations and need long cable connection. The high  $dv/dt$  of the inverter output pulses, through the long cable, doubles at motor terminal due to voltage reflection phenomena.

The overvoltage appearing across the motor terminal stresses the motor insulation and finally leads to motor insulation failure.

According to IEC and NEMA standards of admissible voltages for various motor type, a  $dv/dt$  of around 5kV/us is considered permissible for most application.

## Slew rate control gate driver

Figure 5. Slew rate control gate driver

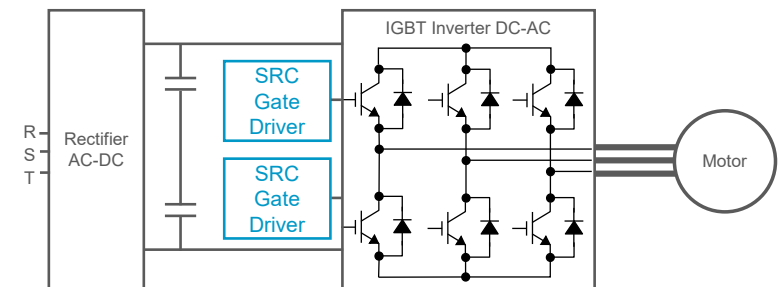

The most commonly used  $dv/dt$  mitigating technique is a passive  $dv/dt$  filter between the inverter and motor. The passive  $dv/dt$  filter consisting of inductor, capacitor and resistor slow down the PWM and reduce the  $dv/dt$ . Such passive filters are usually large, expensive and cause losses.

Slew rate control (SRC) gate driver offers a simple, small and cost-effective alternative to  $dv/dt$  filter. Based on IGBT current feedback loop, the gate driver will control its output current dynamically through the gate resistors. By varying the gate resistors, the  $dv/dt$  of the IGBT can be controlled and not to exceed the permissible  $dv/dt$ .



# Slew rate control gate drive optocoupler

## The operation of slew rate control gate drive optocoupler

Figure 6. The operation of slew rate control gate driver

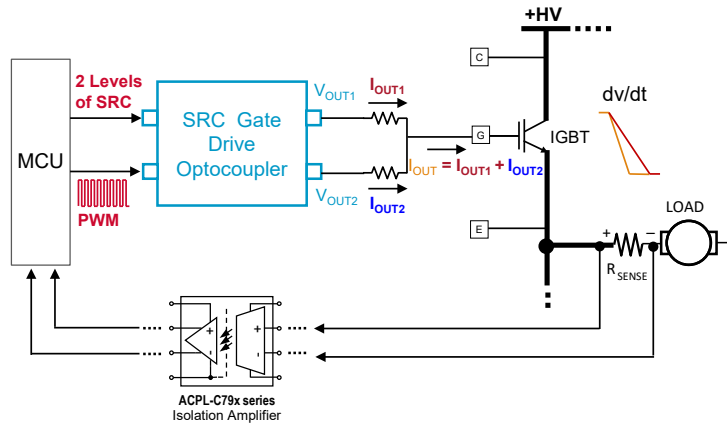

Figure 6 shows typical application diagram of the slew rate control(SRC) gate driver. The SRC gate drive optocoupler receives the PWM and SRC signals from the microcontroller. The PWM signals is then transmitted to across the isolation barrier of the gate driver. The SRC signal will then select the outputs,  $V_{OUT1}$  or  $V_{OUT2}$ , in which the PWM signal will be sent to the gate of the IGBT. The microcontroller decides which mode of SRC levels based on the feedback of the IGBT or load current.

Figure 7 maps the IGBT current,  $I_c$  to the required gate current, in order to keep the  $dv/dt$  below the permissible  $dv/dt$  of 5kV/us. At low IGBT current, for example 40A, the gate driver will deliver a low output current,  $I_{OUT1}$  to keep the IGBT slew rate at 2500V/us. On the other hand, in a design without slew rate control, a high gate current might cause the  $dv/dt$  to exceed the permissible limits at 6kV/us at 40A.

When the IGBT is switching at a higher current, for example 120A.The gate driver will deliver a higher gate current,  $I_{OUT1}+I_{OUT2}$ , to switch the IGBT at a higher slew rate but still within the permissible target. But doing do, the  $dv/dt$  will be higher but optimized(green dotted line), to reduce the switching losses.

Figure 7. The relationship of  $dv/dt$ , IGBT current( $I_c$ ) and gate current

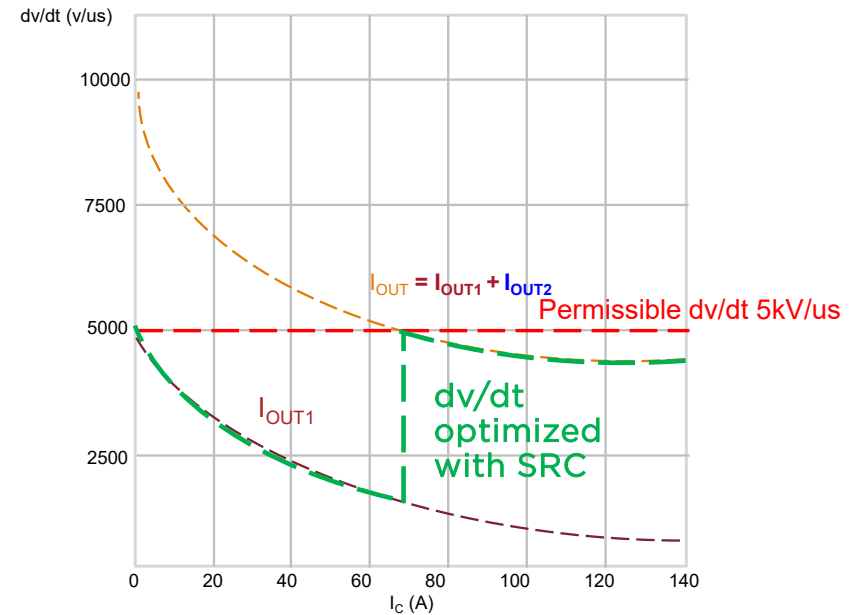

Table 2. Gate drive optocouplers with slew rate control

| Gate Drive Optocoupler | Selectable Output Current (max.) | Other Features  |
|------------------------|----------------------------------|---|
| ^ACFJ-3405             | 12A, 4A                          | <ul style="list-style-type: none"> <li>• DESAT detection with soft shut down</li> <li>• Adaptive DESAT blanking</li> <li>• Deadtime control</li> <li>• Functional safety</li> </ul> |
| ^ACPL-C361             | 5A, 2.5A                         | -   |
| ^ACPL-C362             | 5A, 2.5A                         | Active Miller clamp   |

^ Advance information subject to change.

# Functional safety for motor drive with ACFJ-3405

## Safe Torque Off (STO)

Figure 8. Motor drive functional safety with STO-signal

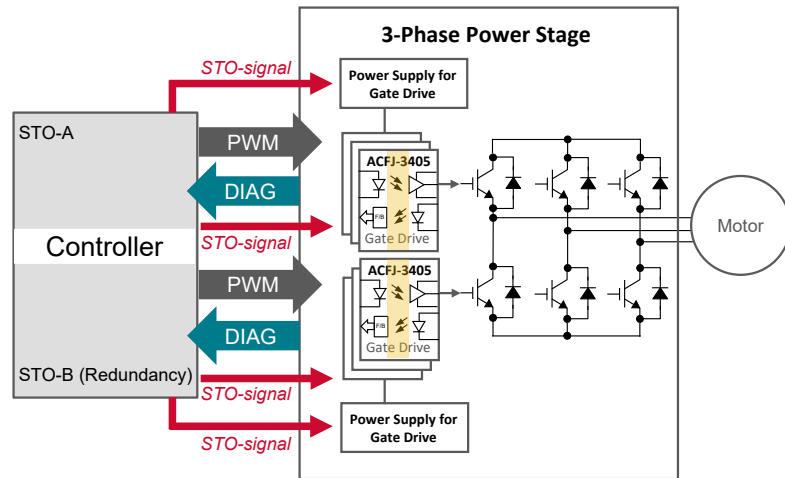

Motor drive functional safety standard, IEC 61800-5-2 defines STO (Safe Torque Off) as the function to prevent force producing power to be provided to the motor. Two of such functions are:

- Function to disable power supply to gate drive
- Function to disable gate drive at the power stage

STO-signal can be sent to these two functions to stop the motor if faults at the power supply or the power stage are detected. The ACFJ-3405, slew rate control gate driver, has integrated functional safety features which can provide diagnostic(DIAG) feedbacks for the controller to issue the necessary STO-signal.

Table 3. ACFJ-3405 features for functional safety

| Power Supply       |  |                |   |
|--------------------|--|----------------|---|
| ACFJ-3405 Features | Description of Fault and Actions   | DIAG Signal    | STO-Signal  |
| UVLO2              | $V_{CC2}$ under voltage. Gate driver locks output and reports status.  | /UVLO<br>/DIAG | Disable secondary power supply  |
| OV2                | $V_{CC2}$ overvoltage. Gate driver reports status.   | /UVLO          |   |
| UVLO1              | $V_{CC1}$ under voltage. Gate driver ignores PWM signal and reports status.  | /UVLO          | EN - Disable gate drive to prevent faulty primary IC PWM signal from driving LED1 |
| Power Stage        |  |                |   |
| DESAT              | Short circuit faults at the IGBT or Motor causing IGBT to desaturate. Gate driver softshuts IGBT and reports status.         | /INT           | EN - Disable gate drive to prevent damaging other IGBTs and motor                 |
| Gate Fault         | Gate(Input) of IGBT is at different logic vs PWM signal. IGBT is not switching according to PWM. Gate driver reports status. | /DIAG          | EN - Disable gate drive to prevent IGBT from driving the motor wrongly            |

The ACFJ-3405 also has a built-in self test (BIST) feature to check the integrity of the DIAG feedbacks. If the LEDs of the PWM or DIAG signaling are not working, LED faults will also be feedback to the controller via /DIAG signal.

# New product highlights – smart gate drive optocouplers

## ^ACFJ-3405

Slew rate control & functional safety

- 2-level(4A & 12A) of output drive
- Adaptive DESAT blanking
- DESAT detection with Soft shutdown protection and fault feedback
- Dead time control
- Gate status fault feedback
- UVLO/OV feedback
- Built-in Self-Test for LED1 & LED2
- -40°C to +125°C operating temperature

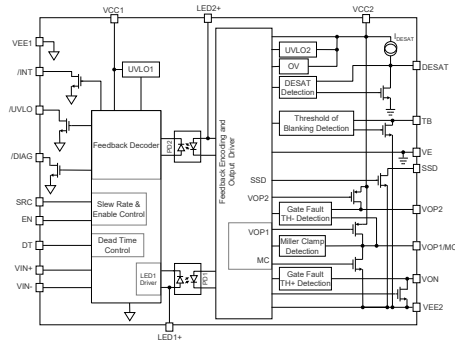

## ACPL-339J

To drive external MOSFET buffer

- Dual rail-to-rail output
- 1A peak output current
- Active timing control to prevent cross conduction in MOSFET buffer
- DESAT and UVLO detection with isolated fault feedback
- Adjustable soft shut down

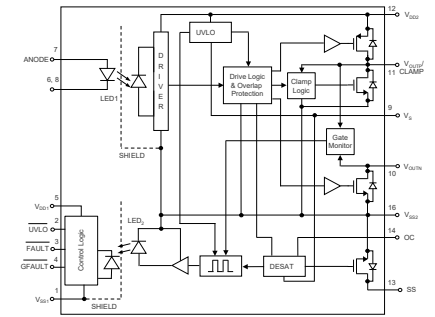

## ACPL-355JC

10A peak output current

- CTI > 600V, material Group I package
- V<sub>IORM</sub> = 2262V<sub>PEAK</sub> continuous working voltage
- Over current FAULT protection & feedback
- UVLO & feedback
- Integrated active Miller clamp
- CMTI >100 kV/μs

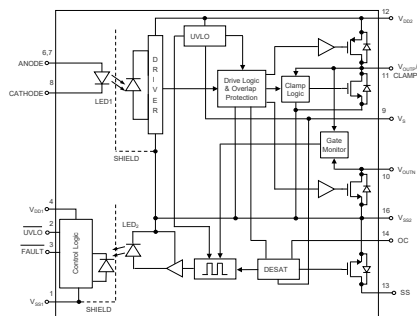

## ACPL-334J/338J

3A peak output current

- Pin-to-pin drop-in to ACPL-332J/331J and ACPL-333J/330J
- Integrated active Miller clamp
- CMTI >100 kV/μs
- -40°C to +125°C operating temperature range

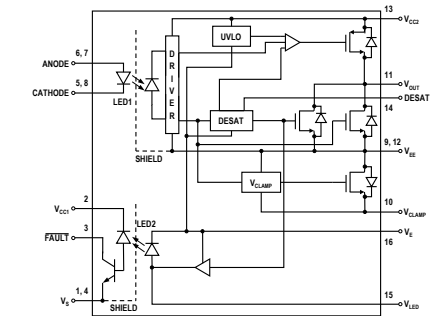

## ACPL-352JC

5A peak output current

- Rail-to-rail dual output
- Over current FAULT protection & feedback
- UVLO & feedback
- Gate status fault feedback
- Adjustable soft shut
- Integrated active Miller clamp
- CMTI >100 kV/μs

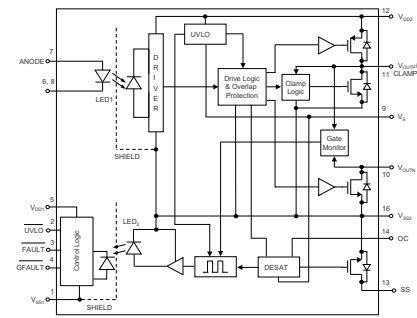

## ACPL-302J

Integrated flyback controller for isolated DC-DC converter

- 2.5 A peak output current
- Rail-to-rail output voltage
- DESAT and UVLO detection with isolated fault feedback
- Integrated active Miller clamp

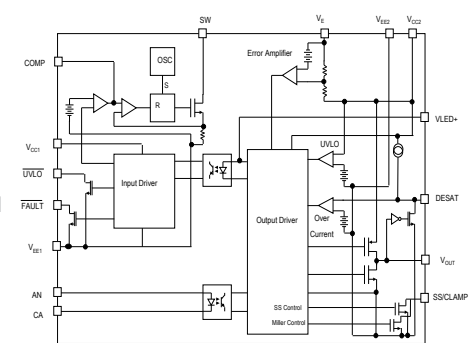

^ Advance information subject to change.

# New product highlights – basic gate drive optocouplers

## ^ ACPL-C361/C362

Slew rate control & miller clamp

- 2-level ON/OFF (2.5A & 5A) of output drive
- Compact SSO-8 package
- ACPL-C362 integrated with active miller clamp
- CMTI >100 kV/μs
- -40°C to +125°C operating temperature

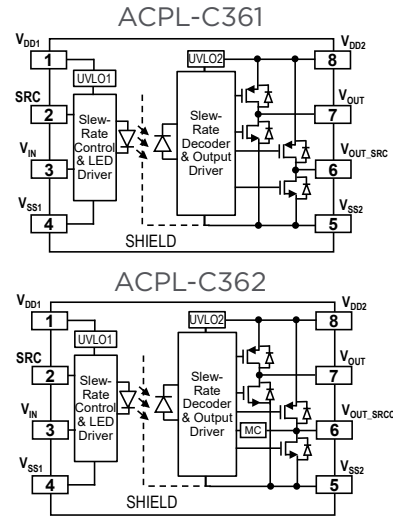

## ACFJ-3262

Dual Channel 10A peak output current

- Dual channel gate drive
- Separate source and sink pins
- Direct LED input
- Fast propagation delay >95ns
- 2.8-mm creepage between 2 output drivers
- CMTI >100 kV/μs
- CTI > 600V, material Group I package
- -40°C to +125°C operating temperature

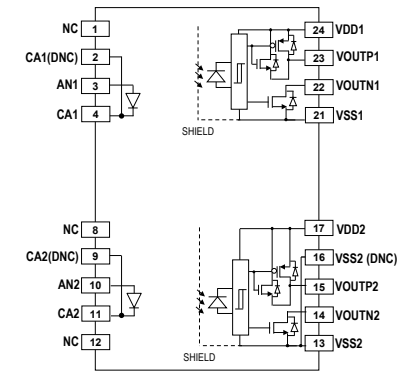

## ^ ACFJ-332B/302C

Dual Channel 4A peak output current with dead time control

- Dual channel gate drive
- Programmable dead time
- Fast propagation delay >65ns
- EN pin for enhanced safety
- Integrated active Miller clamp
- 3.5-mm creepage between 2 output drivers
- $V_{IORM} = 1414 V_{PEAK}$  continuous working voltage
- High CMTI >150 kV/μs
- -40°C to +125°C operating temperature
- UVLO options
  - ACFJ-332B = 8V
  - ACFJ-302C = 12V

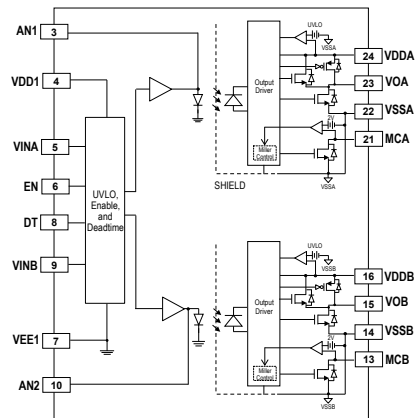

## ACFL-3161

Single Channel 10A peak output current

- Separate source and sink pins
- Direct LED input
- Fast propagation delay >95ns
- CMTI >100 kV/μs
- CTI > 600V, material Group I package
- -40°C to +125°C operating temperature

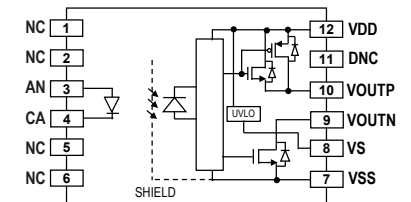

^ Advance information subject to change.





Basic Gate Drive Product Selection

| Part No.             | Package            | I <sub>F(ON)</sub><br>mA<br>Min. | I <sub>OUT</sub><br>A<br>Min. | I <sub>OUT</sub><br>A<br>Max. | t <sub>PLH</sub><br>μs<br>Max. | t <sub>PHL</sub><br>μs<br>Max. | P <sub>DD</sub><br>μs<br>Max. | V <sub>CC</sub><br>V<br>Max. | CMR - V/μs@V <sub>CM</sub> |                      | V <sub>ISO</sub><br>V <sub>RMS</sub><br>Min. | V <sub>IORM</sub><br>V <sub>PEAK</sub> |
|----------------------|--------------------|----------------------------------|-------------------------------|-------------------------------|--------------------------------|--------------------------------|-------------------------------|------------------------------|----------------------------|----------------------|--|--|
|                      |                    |                                  |                               |                               |                                |                                |                               |                              | CMR<br>V/μs<br>(Min.)      | V <sub>CM</sub><br>V |  |  |
| <b>NEW</b> ACFL-3161 | SSO12              | 10                               | 6.0                           | 10                            | 0.095                          | 0.095                          | 0.035                         | 30                           | 100000                     | 1000                 | 5000   | 1230                                   |
| ACNT-H343            | 15mm Stretched SO8 | 12                               | 4.0                           | 5.0                           | 0.15                           | 0.15                           | 0.09                          | 30                           | 100000                     | 1500                 | 7500   | 2262                                   |
| ACNU-3430            | 11mm SSO8          | 7                                | 4.0                           | 5.0                           | 0.15                           | 0.15                           | 0.09                          | 30                           | 100000                     | 1500                 | 5000   | 1414                                   |
| ACNU-3410            | 11mm SSO8          | 7                                | 2.5                           | 3.0                           | 0.15                           | 0.15                           | 0.09                          | 30                           | 100000                     | 1500                 | 5000   | 1414                                   |
| ACNW-3430            | 400 mil DIP        | 8                                | 4.0                           | 5.0                           | 0.15                           | 0.15                           | 0.09                          | 30                           | 100000                     | 1500                 | 5000   | 1414                                   |
| ACNW-3410            | 400 mil DIP        | 8                                | 2.5                           | 3.0                           | 0.15                           | 0.15                           | 0.09                          | 30                           | 100000                     | 1500                 | 5000   | 1414                                   |
| ACNT-H313            | 15mm Stretched SO8 | 7                                | 2.0                           | 2.5                           | 0.5                            | 0.5                            | 0.35                          | 30                           | 40000                      | 2000                 | 7500   | 2262                                   |
| ACNV-3130            | 500 mil DIP        | 12                               | 2.0                           | 2.5                           | 0.5                            | 0.5                            | 0.35                          | 30                           | 40000                      | 1500                 | 7500   | 2262                                   |
| ACPL-P349            | Stretched SO6      | 7                                | 2.0                           | 2.5                           | 0.11                           | 0.11                           | 0.05                          | 30                           | 100000                     | 1500                 | 3750   | 891*                                   |
| ACPL-W349            | Stretched SO6      | 7                                | 2.0                           | 2.5                           | 0.11                           | 0.11                           | 0.05                          | 30                           | 100000                     | 1500                 | 5000   | 1140*                                  |
| ACPL-P346            | Stretched SO6      | 7                                | 2.0                           | 2.5                           | 0.12                           | 0.12                           | 0.05                          | 20                           | 100000                     | 1500                 | 3750   | 891*                                   |
| ACPL-W346            | Stretched SO6      | 7                                | 2.0                           | 2.5                           | 0.12                           | 0.12                           | 0.05                          | 20                           | 100000                     | 1500                 | 5000   | 1140*                                  |
| ACPL-P347            | Stretched SO6      | 7                                | 0.8                           | 1.0                           | 0.11                           | 0.11                           | 0.05                          | 30                           | 100000                     | 1500                 | 3750   | 891*                                   |
| ACPL-W347            | Stretched SO6      | 7                                | 0.8                           | 1.0                           | 0.11                           | 0.11                           | 0.05                          | 30                           | 100000                     | 1500                 | 5000   | 1140*                                  |
| ACPL-P345            | Stretched SO6      | 7                                | 0.8                           | 1.0                           | 0.12                           | 0.12                           | 0.05                          | 20                           | 100000                     | 1500                 | 3750   | 891*                                   |
| ACPL-W345            | Stretched SO6      | 7                                | 0.8                           | 1.0                           | 0.12                           | 0.12                           | 0.05                          | 20                           | 100000                     | 1500                 | 5000   | 1140*                                  |
| ACPL-P343            | Stretched SO6      | 7                                | 3.0                           | 4.0                           | 0.20                           | 0.20                           | 0.1                           | 30                           | 35000                      | 1500                 | 3750   | 891*                                   |
| ACPL-W343            | Stretched SO6      | 7                                | 3.0                           | 4.0                           | 0.20                           | 0.20                           | 0.1                           | 30                           | 35000                      | 1500                 | 5000   | 1140*                                  |
| ACPL-P341            | Stretched SO6      | 7                                | 2.5                           | 3.0                           | 0.20                           | 0.20                           | 0.1                           | 30                           | 35000                      | 1500                 | 3750   | 891*                                   |
| ACPL-W341            | Stretched SO6      | 7                                | 2.5                           | 3.0                           | 0.20                           | 0.20                           | 0.1                           | 30                           | 35000                      | 1500                 | 5000   | 1140*                                  |
| ACPL-P340            | Stretched SO6      | 7                                | 0.8                           | 1.0                           | 0.20                           | 0.20                           | 0.1                           | 30                           | 35000                      | 1500                 | 3750   | 891*                                   |
| ACPL-W340            | Stretched SO6      | 7                                | 0.8                           | 1.0                           | 0.20                           | 0.20                           | 0.1                           | 30                           | 35000                      | 1500                 | 5000   | 1140*                                  |
| ACPL-H342            | Stretched SO8      | 7                                | 2.0                           | 2.5                           | 0.35                           | 0.25                           | -0.2                          | 30                           | 40000                      | 1500                 | 3750   | 891*                                   |
| ACPL-K342            | Stretched SO8      | 7                                | 2.0                           | 2.5                           | 0.35                           | 0.25                           | -0.2                          | 30                           | 40000                      | 1500                 | 5000   | 1140*                                  |
| ACPL-312U            | 300 mil DIP        | 7                                | 2.0                           | 2.5                           | 0.5                            | 0.5                            | 0.35                          | 30                           | 25000                      | 1500                 | 3750   | 630                                    |
| ACPL-H312            | Stretched SO8      | 7                                | 2.0                           | 2.5                           | 0.5                            | 0.5                            | 0.35                          | 30                           | 15000                      | 1500                 | 3750   | 891*                                   |
| ACPL-K312            | Stretched SO8      | 7                                | 2.0                           | 2.5                           | 0.5                            | 0.5                            | 0.35                          | 30                           | 15000                      | 1500                 | 5000   | 1140*                                  |

| Part No.                             | Package       | I <sub>F(ON)</sub><br>mA<br>Min. | I <sub>OUT</sub><br>A<br>Min. | I <sub>OUT</sub><br>A<br>Max. | t <sub>PLH</sub><br>μs<br>Max. | t <sub>PHL</sub><br>μs<br>Max. | P <sub>DD</sub><br>μs<br>Max. | V <sub>CC</sub><br>V<br>Max. | CMR - V/μs@V <sub>CM</sub> |                      | V <sub>ISO</sub><br>V <sub>RMS</sub><br>Min. | V <sub>IORM</sub><br>V <sub>PEAK</sub> |
|--------------------------------------|---------------|----------------------------------|-------------------------------|-------------------------------|--------------------------------|--------------------------------|-------------------------------|------------------------------|----------------------------|----------------------|--|--|
|                                      |               |                                  |                               |                               |                                |                                |                               |                              | CMR<br>V/μs<br>(Min.)      | V <sub>CM</sub><br>V |  |  |
| ACPL-P302                            | Stretched SO6 | 7                                | 0.2                           | 0.4                           | 0.7                            | 0.7                            | 0.5                           | 30                           | 10000                      | 1000                 | 3750   | 891*                                   |
| ACPL-P314                            | Stretched SO6 | 8                                | 0.4                           | 0.6                           | 0.7                            | 0.7                            | 0.5                           | 30                           | 25000                      | 1000                 | 3750   | 891*                                   |
| ACPL-W302                            | Stretched SO6 | 7                                | 0.2                           | 0.4                           | 0.7                            | 0.7                            | 0.5                           | 30                           | 10000                      | 1000                 | 5000   | 1140*                                  |
| ACPL-W314                            | Stretched SO6 | 8                                | 0.4                           | 0.6                           | 0.7                            | 0.7                            | 0.5                           | 30                           | 25000                      | 1000                 | 5000   | 1140*                                  |
| ACNW3190                             | 400 mil DIP8  | 10                               | 4.0                           | 5.0                           | 0.5                            | 0.5                            | 0.3                           | 30                           | 15000                      | 1500                 | 5000   | 1414                                   |
| ACNW3130                             | 400 mil DIP8  | 10                               | 2.0                           | 2.5                           | 0.5                            | 0.5                            | 0.35                          | 30                           | 40000                      | 1500                 | 5000   | 1414                                   |
| ACPL-3130                            | 300 mil DIP8  | 7                                | 2.0                           | 2.5                           | 0.5                            | 0.5                            | 0.35                          | 30                           | 40000                      | 1500                 | 3750   | 630*                                   |
| ACPL-J313                            | 300 mil DIP8  | 7                                | 2.0                           | 2.5                           | 0.5                            | 0.5                            | 0.35                          | 30                           | 40000                      | 1500                 | 3750   | 1230                                   |
| ACPL-T350                            | 300 mil DIP8  | 7                                | 2.0                           | 2.5                           | 0.5                            | 0.5                            | 0.35                          | 30                           | 15000                      | 1500                 | 3750   | 630*                                   |
| HCNW3120                             | 400 mil DIP8  | 10                               | 2.0                           | 2.5                           | 0.5                            | 0.5                            | 0.3                           | 30                           | 25000                      | 1500                 | 5000   | 1414                                   |
| HCPL-J312                            | 300 mil DIP8  | 7                                | 2.0                           | 2.5                           | 0.5                            | 0.5                            | 0.35                          | 30                           | 25000                      | 1500                 | 3750   | 1230                                   |
| HCPL-J314                            | 300 mil DIP8  | 8                                | 0.4                           | 0.6                           | 0.7                            | 0.7                            | 0.5                           | 30                           | 25000                      | 1500                 | 3750   | 891                                    |
| HCPL-T250                            | 300 mil DIP8  | 7                                | 0.5                           | 1.5                           | 0.5                            | 0.5                            | -                             | 30                           | 5000                       | 600                  | 3750   | 630*                                   |
| HCPL-T251                            | 300 mil DIP8  | 8                                | 0.1                           | 0.4                           | 1.0                            | 1.0                            | -                             | 30                           | 10000                      | 600                  | 3750   | -                                      |
| HCPL-0302                            | SO8           | 7                                | 0.2                           | 0.4                           | 0.7                            | 0.7                            | 0.5                           | 30                           | 10000                      | 1000                 | 3750   | 566*                                   |
| HCPL-0314                            | SO8           | 8                                | 0.4                           | 0.6                           | 0.7                            | 0.7                            | 0.5                           | 30                           | 25000                      | 1000                 | 3750   | 566*                                   |
| HCPL-3020                            | 300 mil DIP8  | 7                                | 0.2                           | 0.4                           | 0.7                            | 0.7                            | 0.5                           | 30                           | 10000                      | 1000                 | 3750   | 630*                                   |
| HCPL-3120                            | 300 mil DIP8  | 7                                | 2.0                           | 2.5                           | 0.5                            | 0.5                            | 0.35                          | 30                           | 25000                      | 1500                 | 3750   | 630*                                   |
| HCPL-3140                            | 300 mil DIP8  | 8                                | 0.4                           | 0.6                           | 0.7                            | 0.7                            | 0.5                           | 30                           | 25000                      | 1000                 | 3750   | 630*                                   |
| HCPL-3150                            | 300 mil DIP8  | 7                                | 0.5                           | 0.6                           | 0.5                            | 0.5                            | 0.35                          | 30                           | 15000                      | 1500                 | 3750   | 630*                                   |
| HCPL-3180                            | 300 mil DIP8  | 10                               | 2.0                           | 2.5                           | 0.2                            | 0.2                            | 0.09                          | 20                           | 10000                      | 1500                 | 3750   | 630*                                   |
| <b>NEW</b> ACFJ-3262                 | SSO24         | 10                               | 6.0                           | 10                            | 0.095                          | 0.095                          | 0.025                         | 25                           | 100000                     | 1000                 | 5000   | 1230                                   |
| ACFJ-332B <sup>^</sup><br>(8V UVLO)  | SSO24         | --                               | 2.4                           | 4.0                           | 0.065                          | 0.065                          | 0.03                          | 25                           | 150000                     | 1500                 | 5000   | 1414*                                  |
| ACFJ-302C <sup>^</sup><br>(12V UVLO) | SSO24         | --                               | 2.4                           | 4.0                           | 0.065                          | 0.065                          | 0.03                          | 25                           | 150000                     | 1500                 | 5000   | 1414*                                  |
| HCPL-314J                            | SO16          | 8                                | 0.4                           | 0.6                           | 0.7                            | 0.7                            | 0.5                           | 30                           | 25000                      | 1500                 | 5000   | 1414                                   |
| HCPL-315J                            | SO16          | 7                                | 0.5                           | 0.6                           | 0.5                            | 0.5                            | 0.35                          | 30                           | 15000                      | 1500                 | 5000   | 1414                                   |

\*with IEC/EN 60747-5-5 Option 060.

<sup>^</sup> Advance information subject to change.



## Optoisolation Products

Broadcom Inc. offers the industry's best optical isolation technology along with the industry's leading CMR performance. Broadcom also provides a broad range of isolation products with performance features and benefits that are unmatched in the industry for industrial, automotive and EV charging, renewable energy and storage, robotics, data center and mission critical power supply, communications, medical, military and aerospace markets.

Broadcom is focused on technology leadership and category-leading semiconductor and infrastructure software solutions. The company is a global leader in numerous product segments serving the world's most successful companies.

Broadcom combines global scale, engineering depth, broad product portfolio diversity, superior execution and operational focus to deliver category-leading semiconductor and infrastructure software solutions so its customers can build and grow successful businesses in a constantly changing environment.

## Optocoupler Publications and Resources

Selection Guide  
Designer's Guide  
Regulatory Guide  
Application Notes and White Papers

## Product Portfolio

- Multi-Channel Bi-Directional Digital Optocoupler
- High Speed Digital CMOS Logic Gate Optocoupler
- 20 MBd Logic Gate Optocoupler
- 10 MBd Logic Gate/ CMOS Optocoupler
- 8 MBd Logic Gate Optocoupler
- 5 MBd Logic Gate/CMOS Optocoupler
- 1 MBd Transistor Output Optocoupler
- 100 kBd Darlington Transistor Output Optocoupler
- Automotive Grade Optocoupler (R2Coupler®)
- Digital Isolator
- Isolation Amplifier
- Fully Integrated, Hall Effect-Based Linear Current Sensor IC
- Integrated Gate Drive Optocoupler
- Intelligent Power Module Interface Optocoupler
- Industrial Photo MOSFET Relay and Photo Voltaic Driver Products
- Isolated Line Receiver
- Isolated 20 mA Current Loop Transmitter/Receiver
- Isolated Voltage/Current Detector
- High Linearity Analog Optocoupler
- Wideband Analog/Video Optocoupler
- Hermetic High Performance Optocouplers



For more product information: [broadcom.com](https://www.broadcom.com)

Copyright © 2023 Broadcom. All Rights Reserved. Broadcom, the pulse logo, Connecting everything, Avago Technologies, and R<sup>2</sup>Coupler are among the trademarks of Broadcom. The term "Broadcom" refers to Broadcom Inc. and/or its subsidiaries. December 15, 2023