

FH67 Series

0.5mm Pitch, 3.57mm Width, One Action Lock, Vertical Connection FFC/FPC/Shield FFC Connector



OneAction

Flip-Lock Pioneer **H**irose



One Action



Robust



High Temp

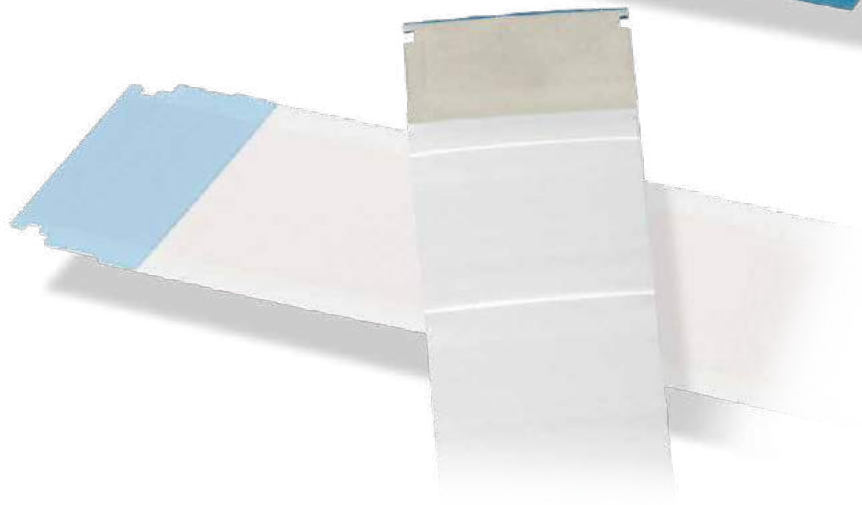
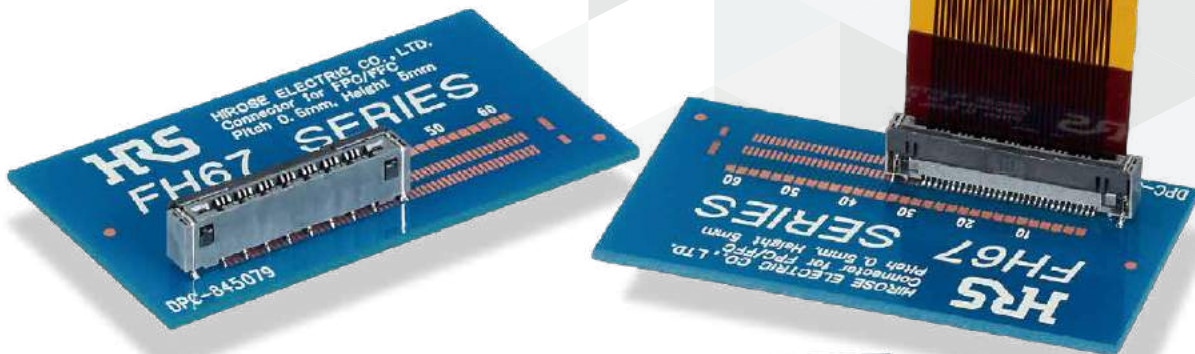

Features

1. Automatic one action lock design

- One action locking by simply inserting FPC after mounting contributes to enhanced workability. (Use the lock lever to release the lock during removal.)
- Operation of the lock lever is not required at the time of mating FPC. Can be inserted with one hand. Contributes to reduced assembly time. The lock lever will not be damaged by operation. Mating failure due to FPC displacement does not occur during lock lever operation.

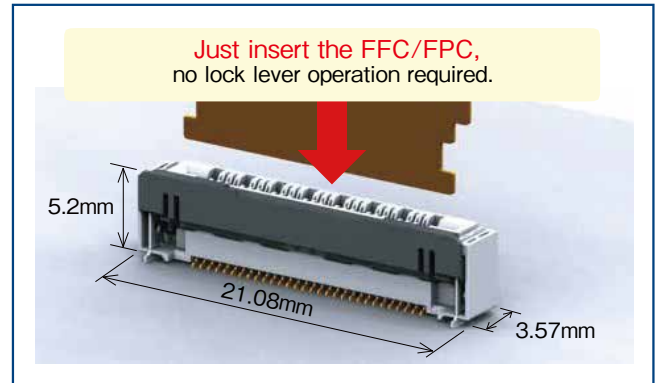

One Action Lock (Dimensions Shown : 30pos.)

2. Two-point contact prevents contact failure by dust

- 2-point contact design with independent springs prevent contact failure due to dust for high contact reliability.

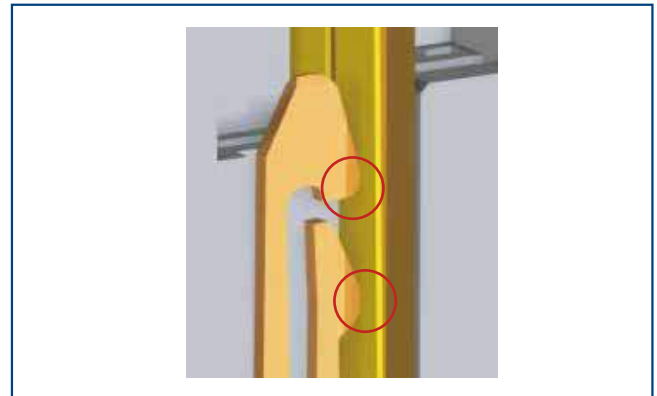

Two-point Independent Spring Contact

3. Supports FFC/FPC/Shield FFC

- FH67 allows you to choose from FFC/FPC/Shield FFC.
- Compatible with shield FFC for EMI prevention.

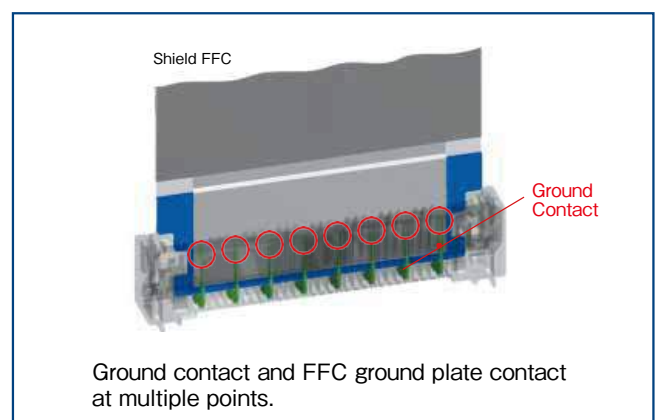

Shield FFC Compatible for EMI Prevention

4. High FPC retention force

- After the FFC/FPC insertion is completed in one action, the circuit automatically locks. The lock lever holds the notches on both sides of the FPC, generating a high FPC retention force even at low pin counts.

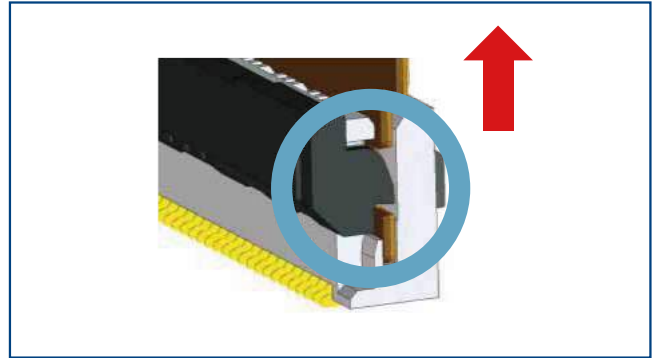

Robust Lock Firmly Secures FFC/FPC

5. Visual FFC/FPC Insertion Status Confirmation

- Insufficient insertion during assembly is prevented due to lock lever protrusion visible after FFC/FPC insertion.

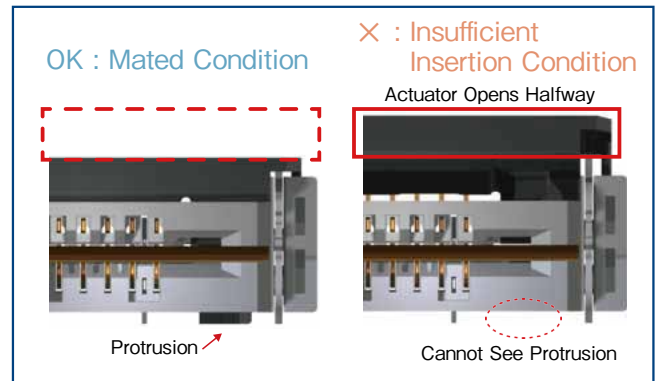

FFC/FPC can be checked from the top surface after mating.

6. Environmental Compatibility

- Halogen Free

*As defined by IEC 61249-2-21.

Br : 900ppm max, Cl : 900ppm max, Br+Cl : 1,500ppm max

Product Specifications

Rated Current	0.5A
Rated Voltage	50V AC/DC
Operating Temperature (Note 1)	-55 to +125°C
Operating Humidity Range	Relative Humidity 90% Max.(No Condensation)
Storage Temperature (Note 2)	-10 to +60°C
Storage Humidity Range	Relative Humidity 90% Max.(No Condensation)
Adaptive FPC Contact Specifications	Thickness : = 0.33 ± 0.03mm Signal Layout : Gold Plated, GND plate : Tin Pated

Note 1 : Includes temperature rise due to current flow.

Note 2 : The term "storage" refers to products stored for long period of time prior to mounting and use.

Operating Temperature and Humidity Range covers non-conducting condition of installed connectors in storage, shipment or during transportation.

Item	Specification	Condition
Insulation Resistance	500M Ω Min.	100V DC
Withstanding Voltage	No flashover or insulation breakdown	150V AC for 1 min.
Contact Resistance	[FPC] First cycle : 60m Ω Max. After testing : 80m Ω Max. (Including FPC 8mm conductor resistance) [FFC] First cycle : 80m Ω Max. After testing : 100m Ω Max. (Including FFC 26mm conductor resistance)	Measured at 1mA AC
Mating Durability (Insertion/Withdrawal)	Contact resistance : 80m Ω Max. (FPC) 100m Ω Max. (FFC) No damage, cracks, or parts dislocation	10 cycles
Vibration	No electrical discontinuity of 1 μs or more Contact resistance : 80m Ω Max. (FPC) 100m Ω Max. (FFC) No damage, cracks, or parts dislocation	Frequency : 10 to 55Hz, single amplitude of 0.75mm, 10 cycles in each of the 3 directions
Shock	No electrical discontinuity of 1 μs or more Contact resistance : 80m Ω Max. (FPC) 100m Ω Max. (FFC) No damage, cracks, or parts dislocation	Acceleration of 981m/s ² , duration of 6 ms, sine half-wave waveform, 3 cycles in each of the 3 axes
Damp Heat (Steady State)	Contact resistance : 80m Ω Max.(FPC) 100m Ω Max.(FFC) Insulation resistance : 50M Ω Min. No damage, cracks, or parts dislocation	96 hours at temperature of 60°C and humidity of 90% to 95%
Temperature Cycle	Contact resistance : 80m Ω Max.(FPC) 100m Ω Max.(FFC) Insulation resistance : 50M Ω Min. No damage, cracks, or parts dislocation	Temperature : -55 → +15 to +35 → +125 → +15 to +35°C Time : 30 → 2 to 3 → 30 → 2 to 3 (Minutes) 1000 cycles
Resistance to Soldering Heat	No deformation of components affecting performance	Reflow : Recommended Temperature Profile Manual Soldering : 350 ± 10°C for 5 seconds

Note 1 : Includes temperature rise due to current flow. The heat resistance when using FFC is 105°C .

When the heat resistance temperature is less than 125°C for FPC and 105°C for FFC, the heat resistance temperature of the FPC/FFC is applicable.

Note 2 : The term "storage" refers to products stored for long period of time prior to mounting and use.

Operating Temperature and Humidity Range covers non-conducting condition of installed connectors in storage, shipment or during transportation.

Materials / Finish

Part	Materials	Finish	UL Standard
Insulator	LCP	Grey	UL94V-0
	LCP	Black	UL94V-0
Signal Contact	Copper Alloy	Nickel Barrier Gold Plated	-
Ground Contact	Copper Alloy	Pure Tin Reflow Plated	-
Reinforcing Retention Tabs	Copper Alloy	Pure Tin Reflow Plated	-

Product Number Structure

Refer to the chart below when determining the product specifications from the product number.
Please select from the product numbers listed in this catalog when placing orders.

FH67 - 30S - 0.5 SV (99)

① ② ③ ④ ⑤

① Series Name	FH67	④ Terminal Type	SV : SMT Vertical Mounting Type
② No. of Pos.	10-40	⑤ Specification	Blank : Standard 1,000pcs/reel
③ Contact Pitch	0.5mm		(99) : 500pcs/reel

Connector Dimensions

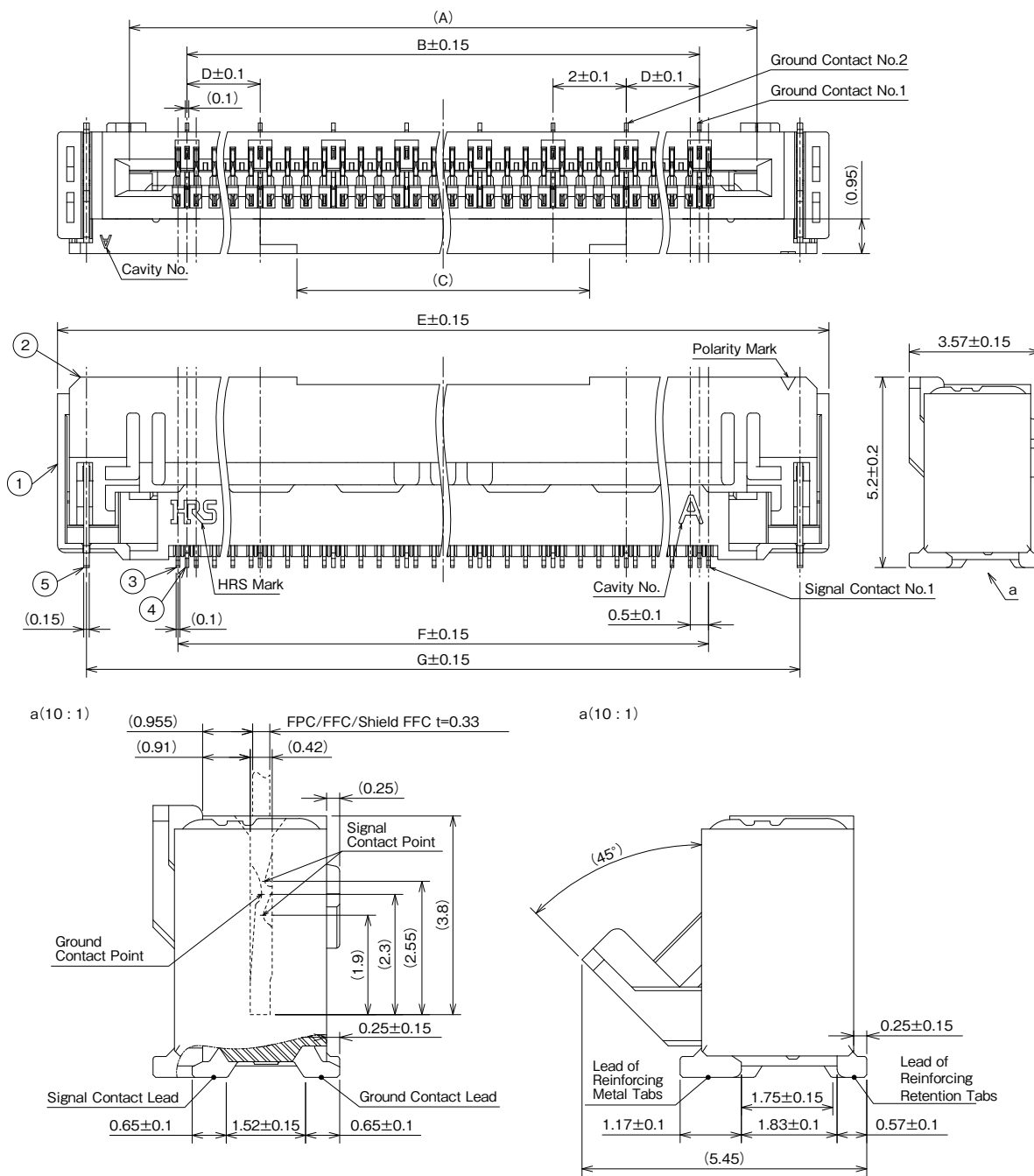

- Note 1 : The dimensions in parentheses are for reference.
 Note 2 : Lead co-planarity including lead of reinforcing metal tabs shall be 0.1mm max.
 Note 3 : Delivered in tape and reel packaging.
 See the packaging specifications for details.
 Note 4 : Note that a preventive hole for sink mark or slit could be added for improvement.
 Note 5 : Dark spots may appear on the molded plastic, however this does not represent a quality issue.
 Note 6 : This product satisfies halogen free requirements defined as 900ppm maximum chlorine, 900ppm maximum bromine, and 1500ppm maximum total of chlorine and bromine.

Unit : mm

Part No.	HRS No.	No. of Pos.	A	B	C	D	E	F	G	Purchase Unit	
										(#):(00)	(#):(99)
FH67-10S-0.5SV	CL0580-4900-0-##	10	7.15	4.0	5.0	2.0	11.08	4.5	9.5	1000pcs per reel	500pcs per reel
FH67-20S-0.5SV	CL0580-4906-0-##	20	12.15	9.0	7.5	1.5	16.08	9.5	14.5		
FH67-30S-0.5SV	Under Planning (Note)	30	17.15	14.0	8.0	2.0	21.08	14.5	19.5		
FH67-40S-0.5SV	CL0580-4903-0-##	40	22.15	19.0	17.0	1.5	26.08	19.5	24.5		
FH67-50S-0.5SV	Under Planning (Note)	50	27.15	24.0	17.0	1.5	31.08	24.5	29.5		

Note : Contact positions without HRS No. are currently under planning.
 Please contact HRS for detailed information about product variations.

● Recommended PCB Mounting Pattern

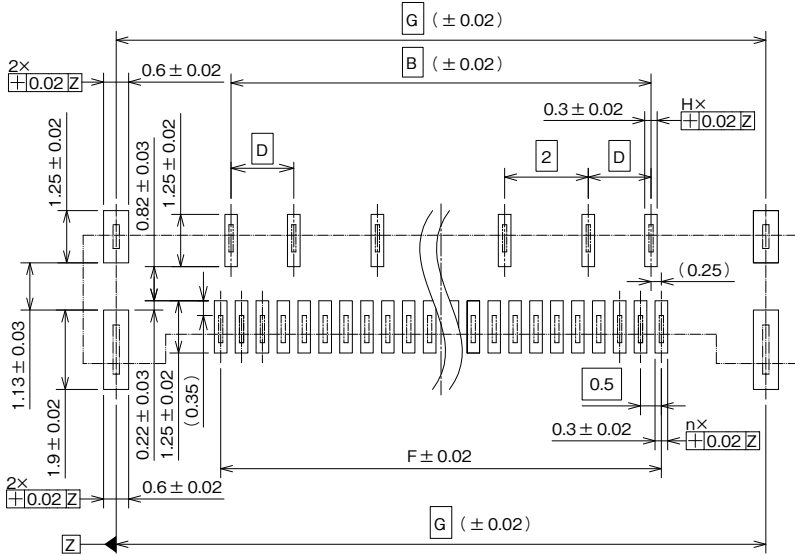

Note : The value 'n' indicates the number of pos.

● Recommended Stencil Pattern

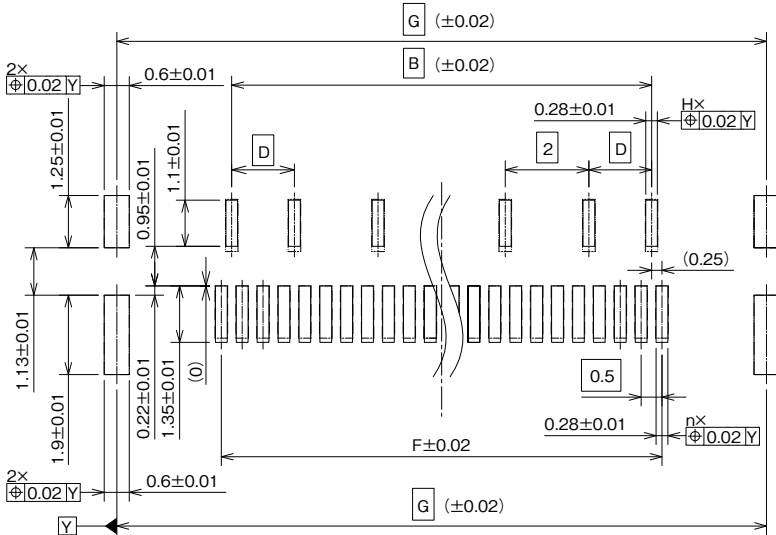

Note : The value 'n' indicates the number of pos.

Unit : mm

Part No.	HRS No.	No. of Pos.	B	D	E	G	H
FH67-10S-0.5SV	CL0580-4900-0-##	10	4.0	2.0	11.08	9.5	3.0
FH67-20S-0.5SV	CL0580-4906-0-##	20	9.0	1.5	16.08	14.5	6.0
FH67-30S-0.5SV	Under Planning (Note)	30	14.0	2.0	21.08	19.5	8.0
FH67-40S-0.5SV	CL0580-4903-0-##	40	19.0	1.5	26.08	24.5	11.0
FH67-50S-0.5SV	Under Planning (Note)	50	24.0	1.5	31.08	29.5	13.0

Note : Contact positions without HRS No. are currently under planning.
Please contact HRS for detailed information about product variations.

Recommended FFC/FPC/Shield FFC Dimensions

● Recommended FFC/FPC Dimensions

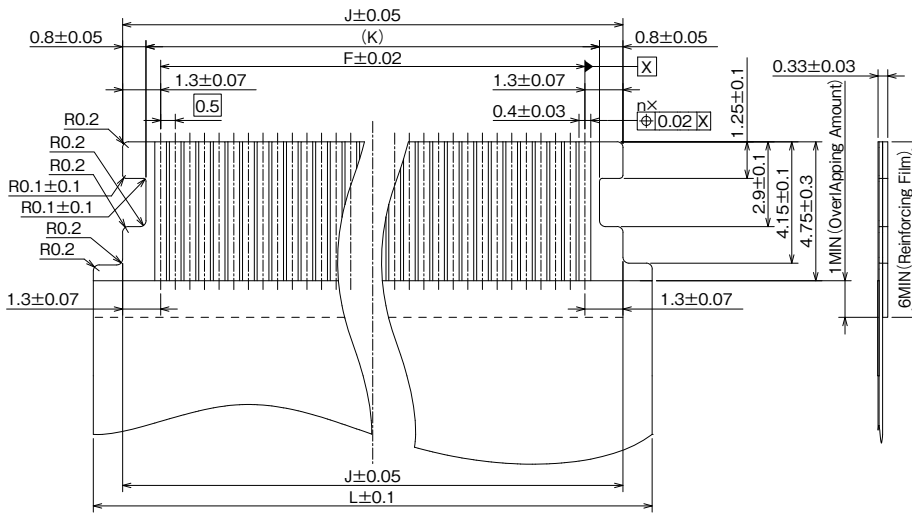

Note : The value 'n' indicates the number of pos.

● Recommended Shield FFC Dimensions

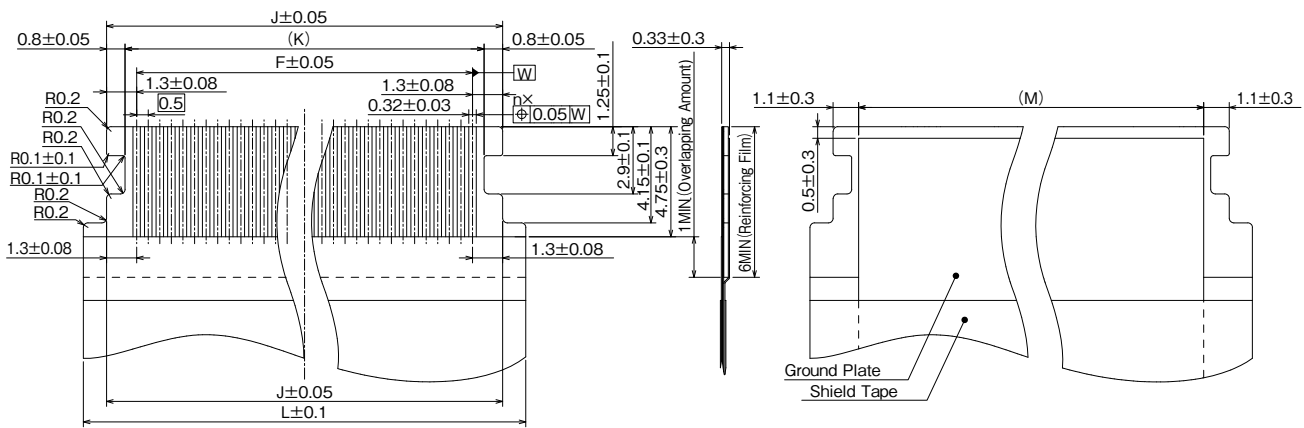

Note 1 : The value 'n' indicates the number of pos.
 Note 2 : Place the shield tape on top of the grounding plate.

Unit : mm

Part No.	HRS No.	No. of Pos.	F	J	K	L	M
FH67-10S-0.5SV	CL0580-4900-0-##	10	4.5	7.1	5.5	9.1	4.9
FH67-20S-0.5SV	CL0580-4906-0-##	20	9.5	12.1	10.5	14.1	9.9
FH67-30S-0.5SV	Under Planning (Note)	30	14.5	17.1	15.5	19.1	14.9
FH67-40S-0.5SV	CL0580-4903-0-##	40	19.5	22.1	20.5	24.1	19.9
FH67-50S-0.5SV	Under Planning (Note)	50	24.5	27.1	25.5	29.1	24.9

Note : Contact positions without HRS No. are currently under planning.
 Please contact HRS for detailed information about product variations.

Recommended FFC/FPC/Shield FPC Composition

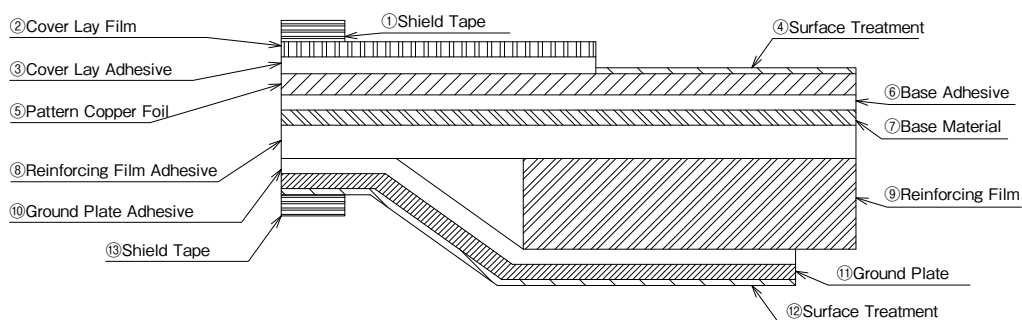

	Material Name	FPC		FFC		
		Materials	Thickness (μm)	Materials	Shield FFC Thickness (μm)	FFC Thickness (μm)
①	Shield Tape	—	—	—	—	—
②	Cover Lay Film	Polyimide 1mil	25	Polyester	25	25
③	Cover Lay Adhesive	Thermosetting Adhesive	28	Adhesive	25	25
④	Surface Treatment	Nickel Underplated 1 to 6μm +Gold Plated 0.2μm	(3.7)	Nickel Underplated 0.5 to 5μm +Gold Plated 0.05 to 1μm	(3.275)	(3.275)
⑤	Pattern Copper Foil	Rolled Copper 1oz	35	Annealed Copper foil	35	35
⑥	Base Adhesive	Thermosetting Adhesive	8	Adhesive	25	25
⑦	Base Material	Polyimide 1mil	25	Polyester	25	50
⑧	Reinforcing Film Adhesive	Thermosetting Adhesive	55	Adhesive	30	30
⑨	Reinforcing Film	Polyimide 8mil	200	Polyester	150	188
⑩	Ground Plate Adhesive	—	—	Adhesive	30	—
⑪	Ground Plate	—	—	Copper foil	37	—
⑫	Surface Treatment	—	—	Tin plated 1 to 5μm	—	—
⑬	Shield Tape	—	—	—	—	—

Note 1 : This specification is recommendation for the construction of the FH67 Series FFC/FPC/Shield FFC (t=0.33 ± 0.03mm)

Note 2 : For details about the construction, please contact FFC/FPC/Shield FFC manufacturers.

Packaging Specifications

● Embossed Carrier Tape Dimensions

Tape Width : 24mm or less

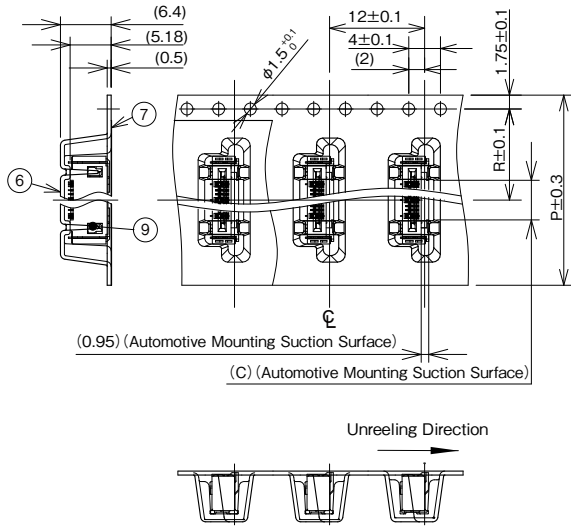

Tape Width : 32mm or less

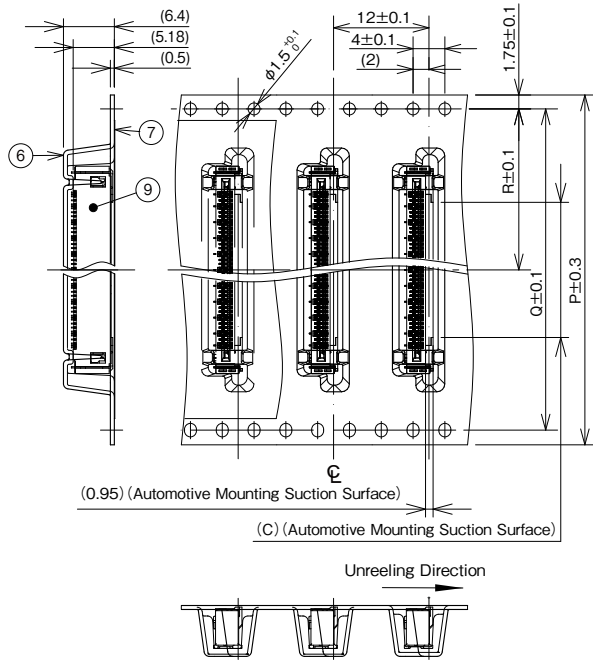

● Reel Dimensions

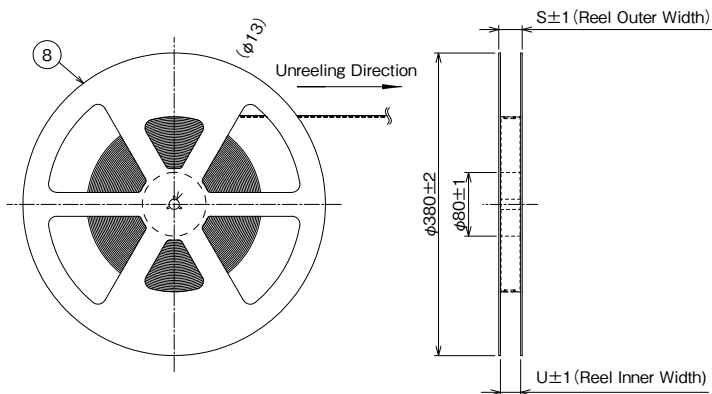

● Leader, Trailer Dimensions

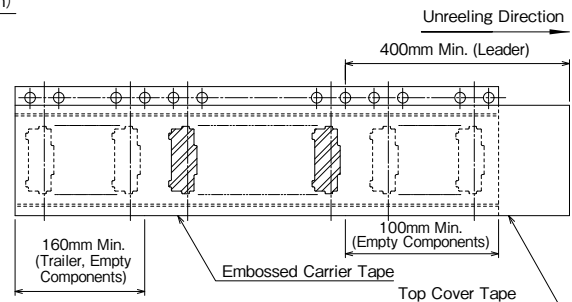

Note : 1000pcs per reel (standard product).
 The package complies with JIS C 0806 and IEC 60286-3
 (Packaging of components for automatic handling).

Unit : mm

Part No.	HRS No.	No. of Pos.	C	P	Q	R	S	U
FH67-10S-0.5SV	CL0580-4900-0-##	10	5.0	24.0	-	11.5	29.4	25.4
FH67-20S-0.5SV	CL0580-4906-0-##	20	7.5	32.0	28.4	14.2	37.4	33.4
FH67-30S-0.5SV	Under Planning (Note)	30	8.0	44.0	40.4	20.2	49.4	45.4
FH67-40S-0.5SV	CL0580-4903-0-##	40	17.0	44.0	40.4	20.2	49.4	45.4
FH67-50S-0.5SV	Under Planning (Note)	50	17.0	56.0	52.4	26.2	61.4	57.4

Note : Contact positions without HRS No. are currently under planning.
 Please contact HRS for detailed information about product variations.

Temperature Profile

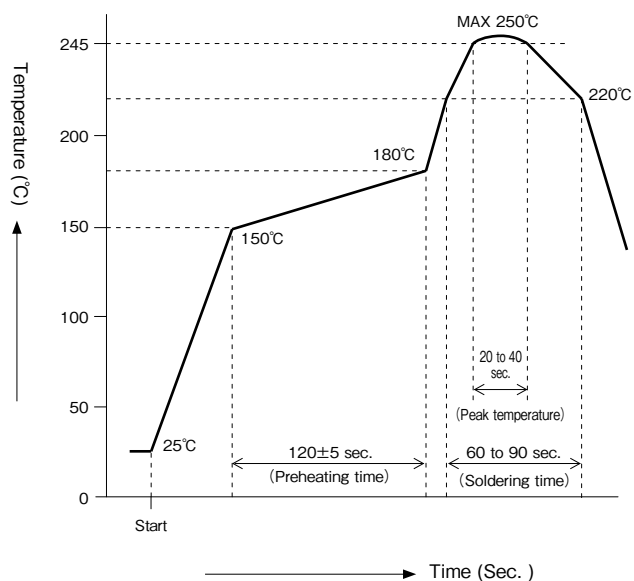

Applicable Conditions

Reflow method : IR/Hot air

Reflow environment : Room air

Solder : Paste type Sn/3.0Ag/0.5Cu

(M705-GRN360-K2-V made by Senju Metal Industry Co.)

Test PCB : PCB material and size

Glass epoxy 45×25×1mm

As Listed in Recommended PCB Mounting Pattern

Metal mask : Thickness and opening size

As Listed in Recommended Metal Mask Dimensions

This temperature profile is based on the above conditions.

It may vastly depending on solder paste type, manufacturer, PCB size and mounting materials. Please use only after checking the mounting conditions.

Connector Operation and Precautions

● Operation Method

Handle this connector with care. To prevent damage to the connector and contact failure (incomplete mating, FPC pattern disconnection), confirm the following before use.

This connector supports FFC/FPC/Shield FFC, however, for convenience, only FPC is listed.

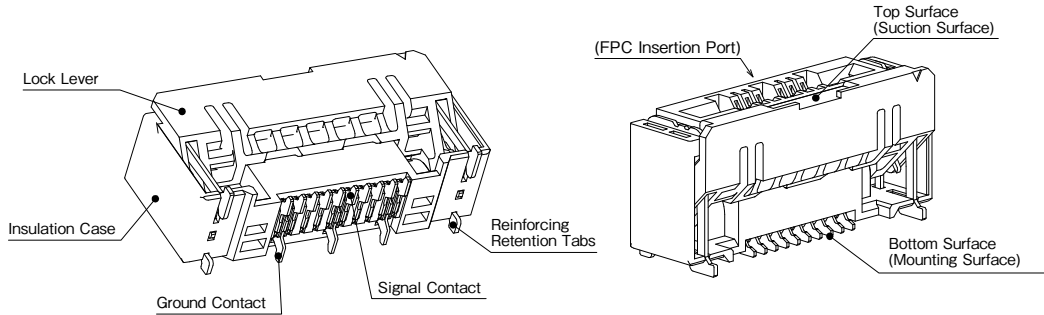

1. Initial Delivery State

This product is delivered with the lock lever closed. The lock lever does not need to be operated before FPC insertion.

[Caution]

- Do not open the lock lever when FPC is not inserted. Additionally, the lock lever does not need to be opened except to remove the FPC. (Ex.1)
- Do not operate the connector until it is mounted on the board. (Ex.1)

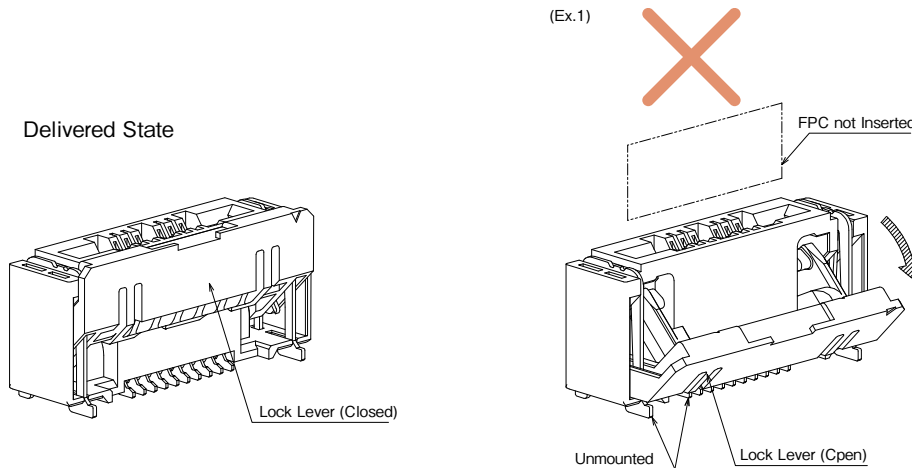

2. FPC Insertion

Insert the FPC fully perpendicular in respect to the board surface (Ex.2).

[Caution]

- Please confirm that the lock lever is closed during FPC insertion.
Do not insert FPC while the lock lever is open. (Ex.3)
Product is designed so that the FPC cannot be inserted when the lock lever is opened. However forcing insertion causes damage.
- Do not insert FPC while at the same time pressing the lock lever. (Ex.4)
- Insert FPC pattern side facing opposite of the operating portion of the lock lever. (Ex.5)
- Insert FPC straight after positioning its tip vertically in reference to the guides on both ends of the connector mating port. (Ex.6)
- Do not insert at an angle to the insertion direction. (Ex.7)
- When inserting, do not move the FPC in a vertical, lateral or diagonal direction. (Ex.8)
(Recommended Insertion Angle $\pm 2.5^\circ$)
- Refrain from opening the lock level with a finger when inserting the FPC. (Ex.9)

(Ex.2)

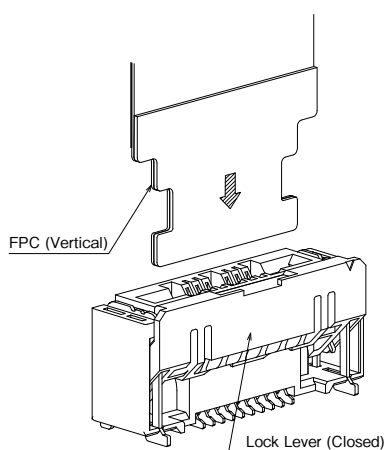

(Ex.3)

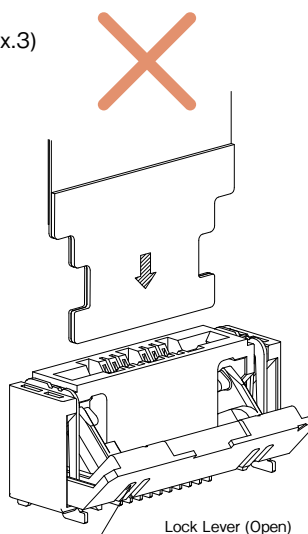

(Ex.4)

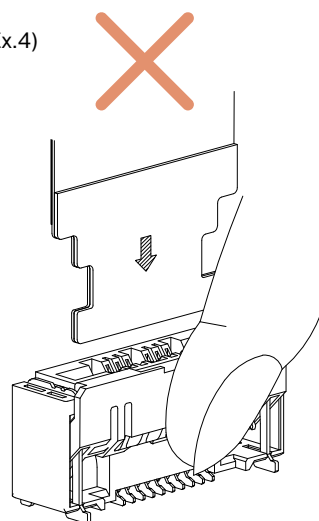

(Ex.5)

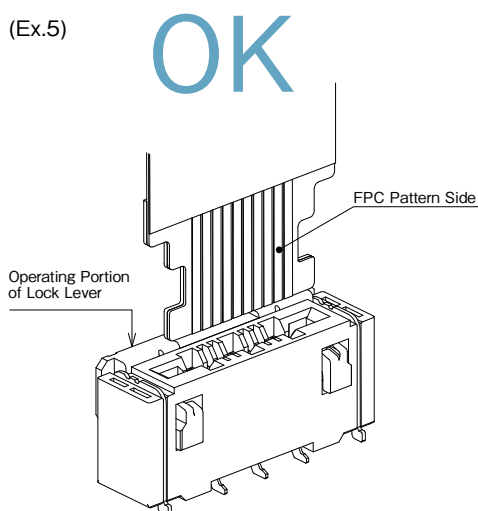

(Ex.6)

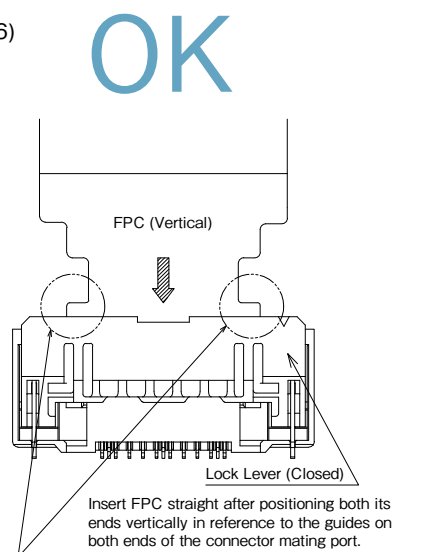

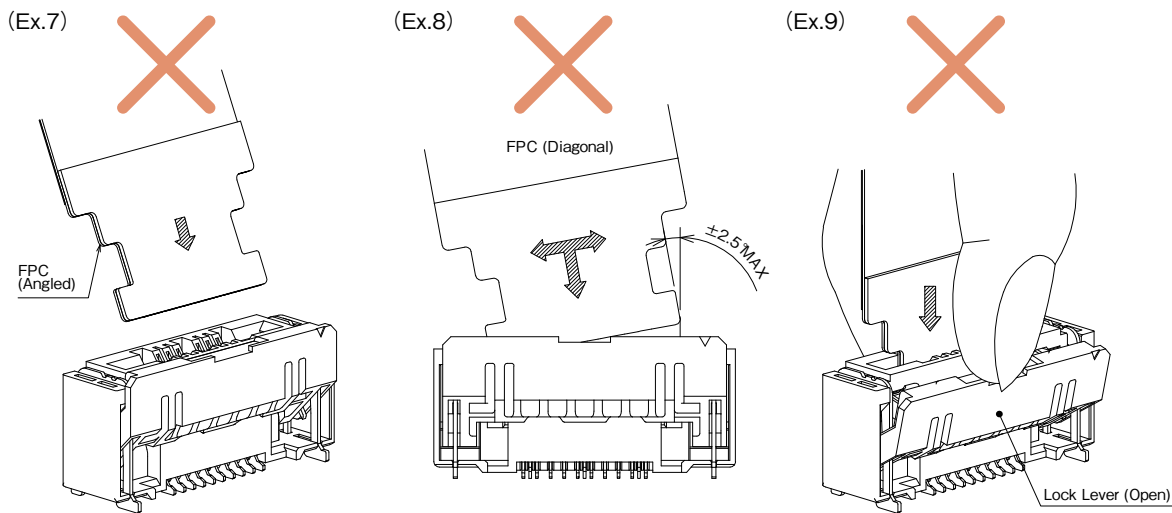

3. FPC Mated State Confirmation

When FPC is completely inserted, visually inspect the inserted status of FPC. (Ex.10)
 (This connector uses the lock protrusion of the lock lever for FPC positioning.)

[Caution]

- Avoid shallow FPC insertion or insertion at a slant. (Ex.11)(Ex.12)
- The lock lever does not need to be operated after FPC insertion due to the one action lock design.

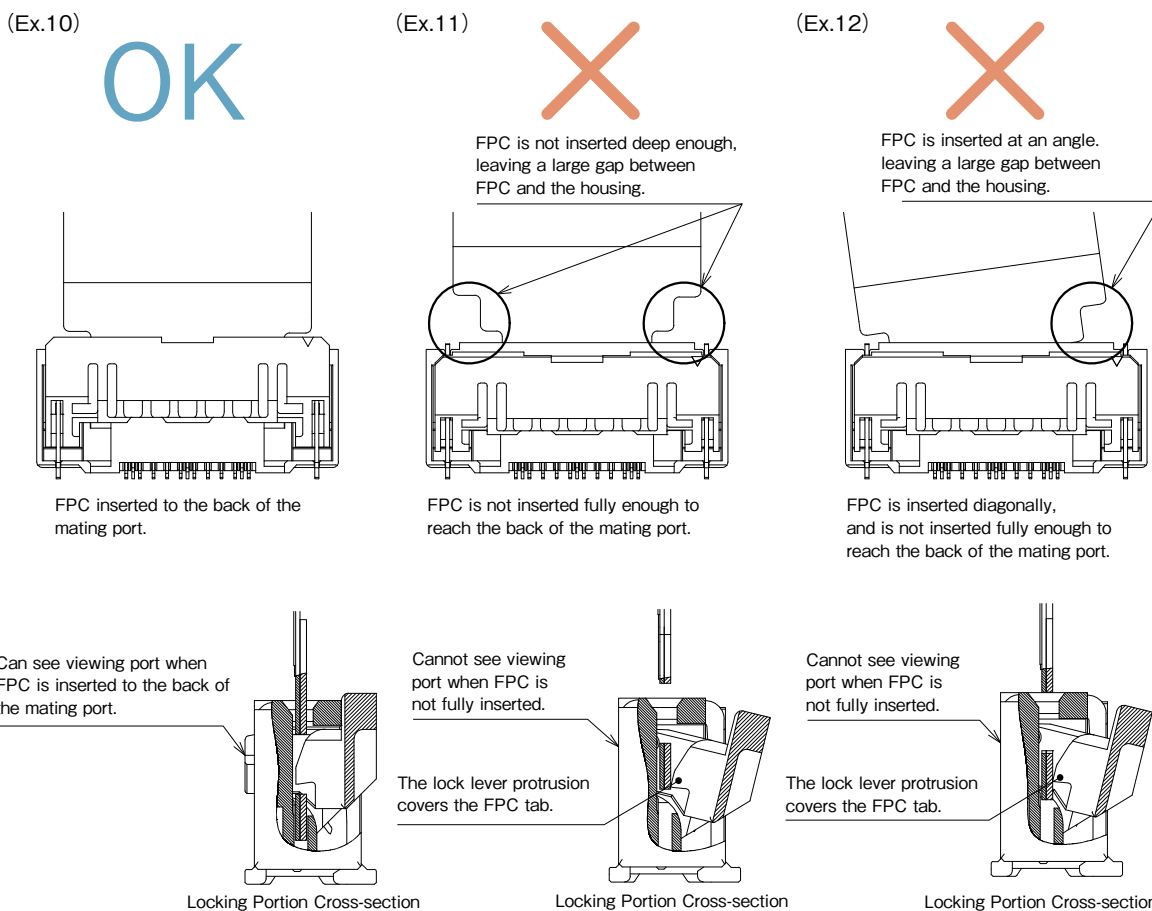

4. How to Unlock the Lock Lever

Push down the lock lever slowly, and release the lock. (Ex.13)

[Caution]

- When releasing the lock operate the lock lever around the center. (Ex.14)
- When releasing the lock do not operate only one side of the lock lever. (Ex.15)
- As the lock lever cannot be opened to over 45°, do not open it over this angle. (Ex.16)
- Do not pick and raise the lock lever or pull it. (Ex.17)
- Be sure to operate the lock lever by hand, and do not operate it with sharp-edged tools such as tweezers etc. (Ex.18)
- Don't apply an excessive force to the housing during operation. (Ex.19)

(Ex.13)

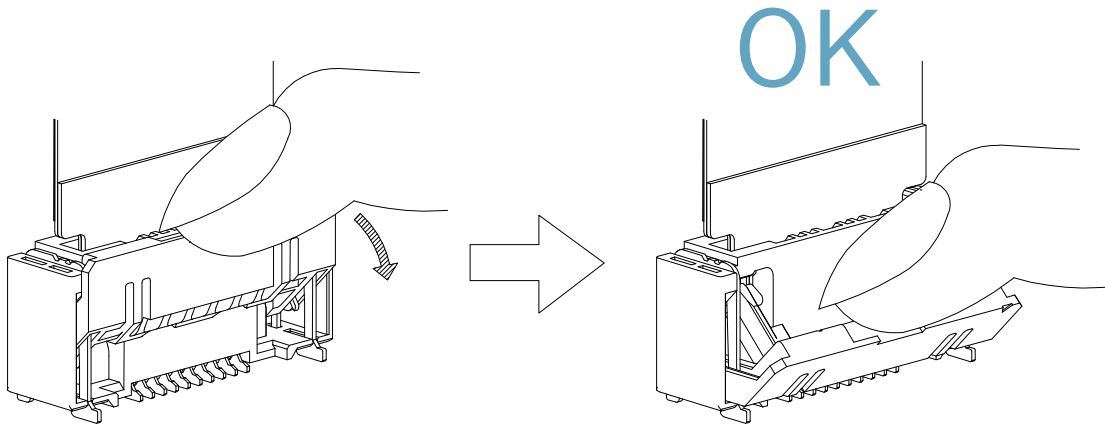

(Ex.14)

OK

Operate the lock lever around the center.

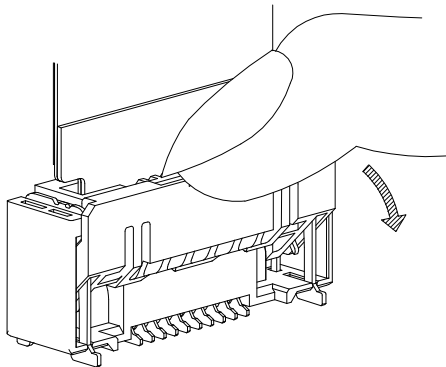

(Ex.15)

X

Operate the lock lever on one side.

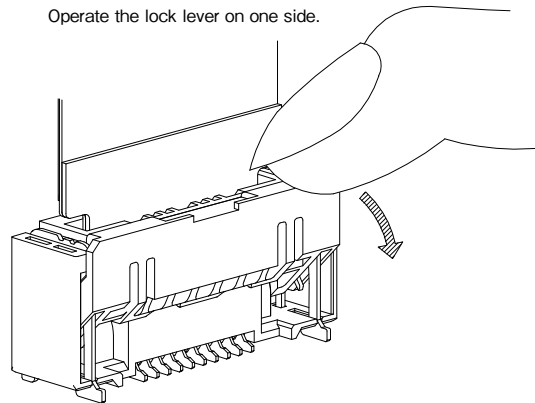

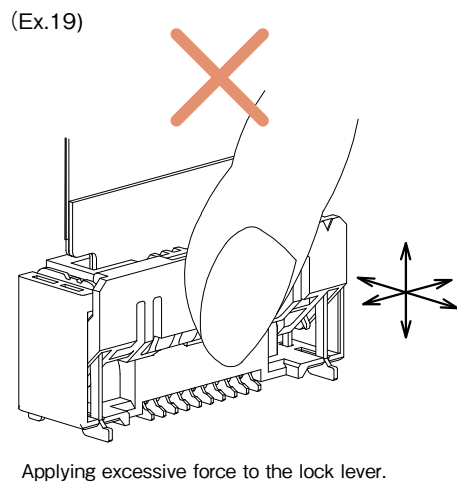
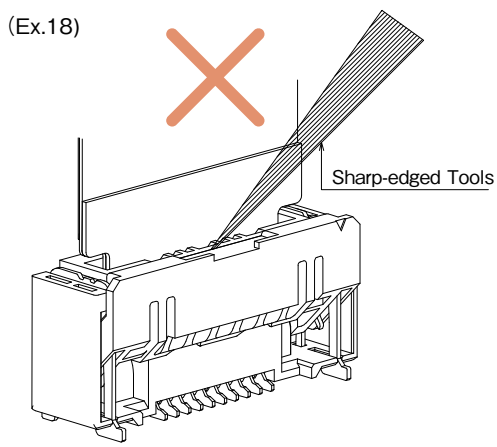
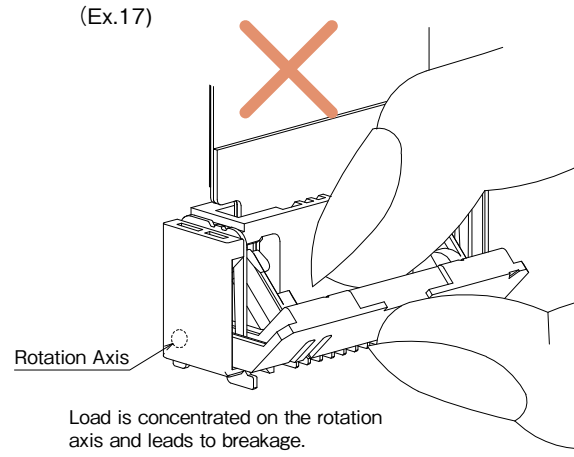
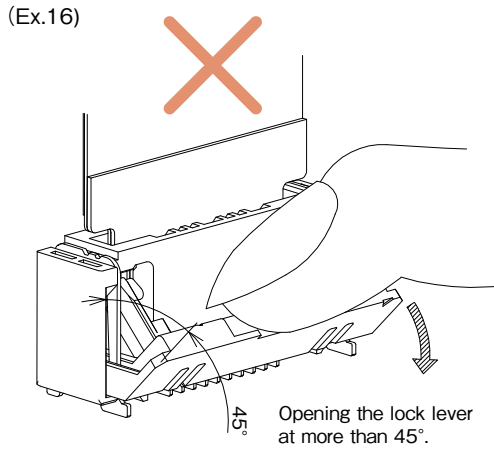

5. FPC Removal Method

After releasing the lock lever, remove the FPC perpendicular to the board surface. (Ex.20)

When removing the FPC do not press the lock lever. (Ex.21)

The released lock lever may close automatically upon removal but this is not a product defect. (Ex.22)

[Caution]

· Do not pull out FPC while the lever is locked. (Ex.23)

There is a possibility of decrease in the FPC's retention force after forcefully removing the FPC.

· The lock lever provides the FPC retention mechanism.

When pulling out FPC, do not apply load in any direction other than perpendicular to the board surface. (Ex.24)

(Ex.20)

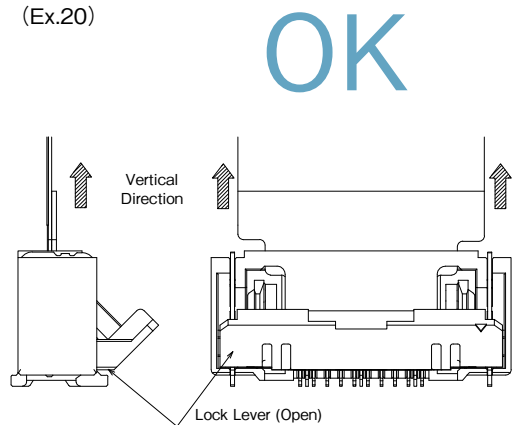

(Ex.21)

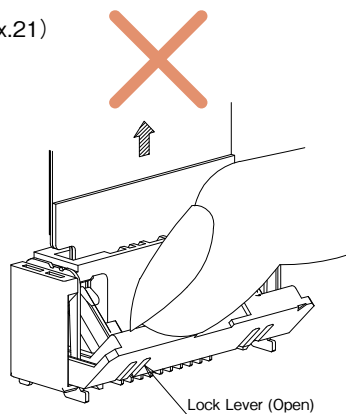

(Ex.22)

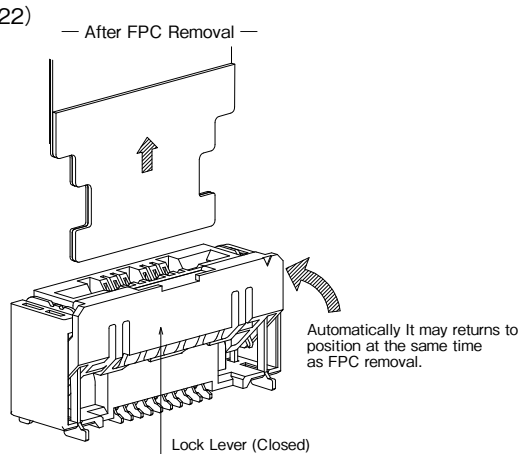

(Ex.23)

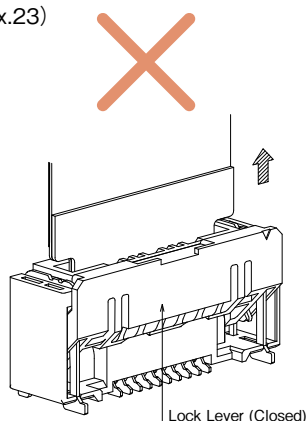

(Ex.24)

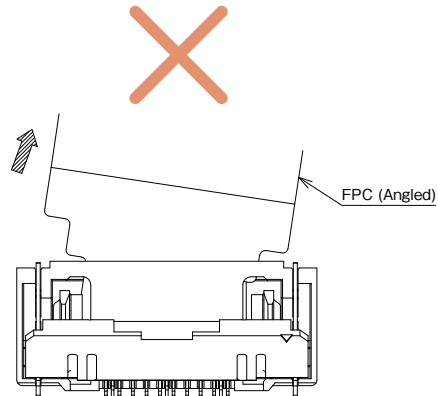
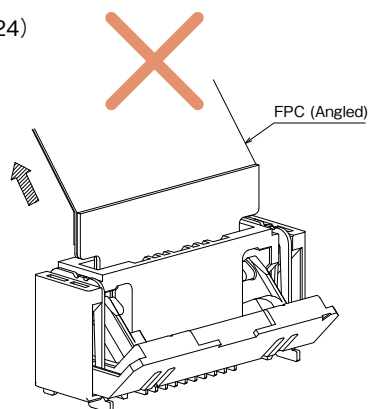

● PCB Layout Precautions

Stress leading to contact failure may be applied to the connector depending on the routing of the FPC the connector will be mated with.

In order to prevent failure, please consider the following during mechanical design.

[Caution]

- When routing the FPC for use, make sure it has enough slack and do not pull tightly.
Please check that the reinforcing film is placed vertical to the board surface. (Ex.25)
- Please ensure there is no load applied to the connector in the pulling, inserting or lateral direction.
Using an FPC bent close to the connector may cause contact failure or FPC damage/disconnection.
Therefore, please take some measure to secure the FPC etc. (Ex.26)(Ex.27)
- Do not place panels or mounted parts that interfere with the FPC.(Ex.28)
- Please make adjustments with FPC manufacturer for FPC flexibility.
- Please ensure the FPC has adequate insertion space when designing the layout so that it is not inserted diagonally.
Additionally, insertion becomes difficult if the FPC is too short, so please ensure an adequate FPC length and component layout.
- When you design the board/layout, please secure required space for operation.

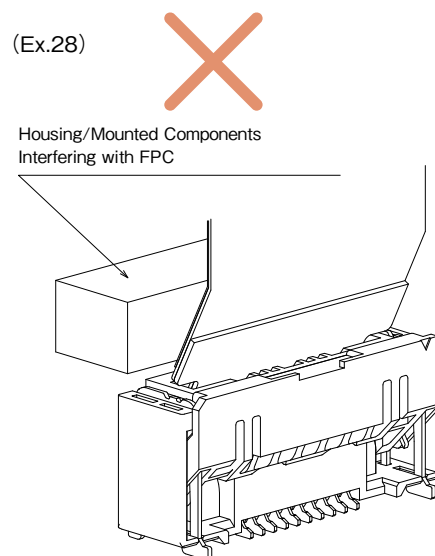
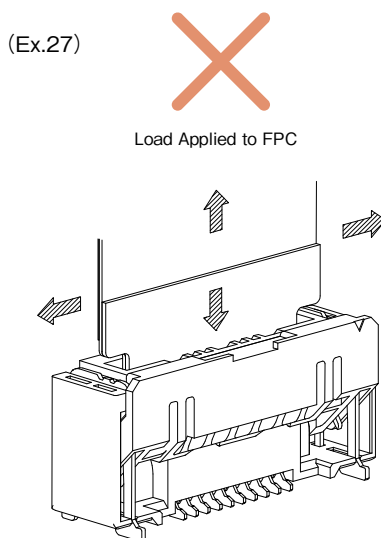
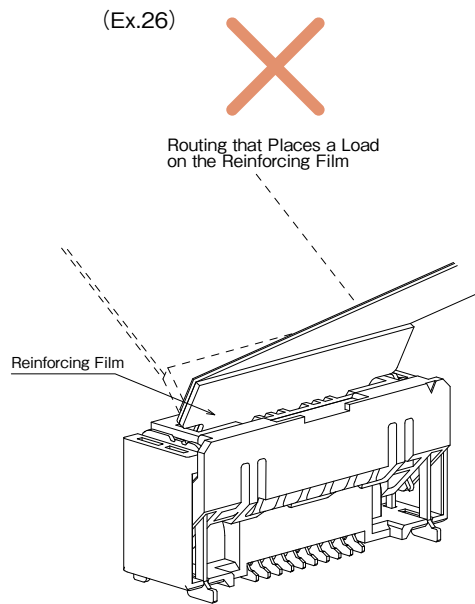
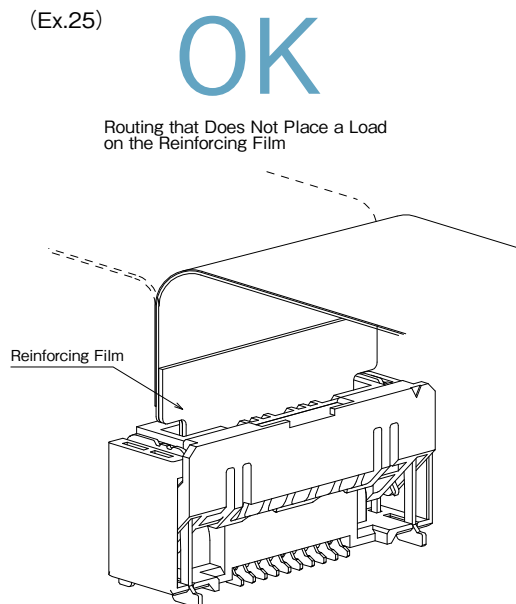

Notes for Board Mounting and After Board Mounting

● Board Mounting Notes

Please be careful of the following at the time of board mounting.

[Caution]

- Please confirm the recommended PCB mounting pattern, metal mask opening size and FPC design.
- If the PCB mounting pattern is narrower than recommended or the metal mask opening is wider than recommended, solder (flux) wicking is more likely to occur.
If there is difference from the recommendation, please use after checking the mounting state.
- The level difference between the bottom surfaces of contact lead and the mold is designed to be minimal. When there is silk print etc. on the bottom surface of the connector, the lower surface of the connector may be pushed up, resulting in solder not applied or defective fillet formation. When there is silk print etc. on the bottom surface of the connector, please use after checking the mounted state.
- Use the reflow conditions within the specifications designated by Hirose. The mounted status may vary due to external conditions such as the paste solder type, manufacturer, and board size. Please use it after checking the mounted state.
- Please control the board warpage as much as possible. While the coplanarity of this connector is 0.1mm or less, defective soldering could occur if the board warpage is considerable.
- When mounted on FPC, be sure to provide a reinforcing plate to ease handling. We recommend a reinforcing plate of 0.3mm or thicker made of glass epoxy material.
- Do not apply excessive force (1N or more) when pulling out the emboss from the reel or suctioning the connector from the emboss.

● Cautions When Handling the Board After Mounting

Please be careful of the following when handling the board after mounting operation.

[Caution]

- Refrain from handling that may put strain on the board during the assembly process, such as splitting a board into several pieces or screwing the board to a frame. Otherwise the connector may be damaged.
- Board deflection should be 1mm or less when the board width is 100mm. (Ex.29) Board deflection may cause stress to the connector resulting in damage.

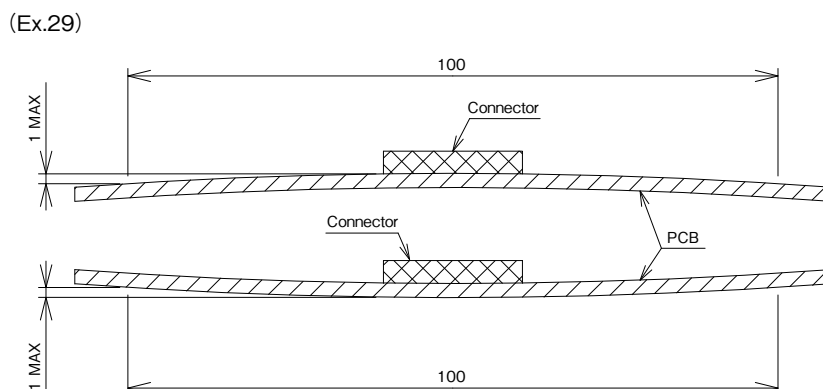

● Cautions for Manual Soldering

Please be careful of the following when hand-soldering for repair work etc.

[Caution]

- Do not perform manual soldering with the FPC inserted in the connector.
- Please be careful not to apply excessive heat or allow the solder iron to touch any place other than the connector contact lead. Failure to do so may result in connector deformation or melting.
- Do not supply an excessive amount of solder (flux). If too much solder (flux) is supplied to the contact, the solder or flux could adhere on the contact point and cause contact failure. Additionally, supplying excessive solder to the retention tabs may result in actuator rotation failure, causing connector damage.

While Taking into Consideration

Specifications mentioned in this catalog are reference values.

When considering to order or use this product, please confirm the Drawing and Product Specifications sheets.

Use an appropriate cable when using the connector in combination with cables.

If considering usage of a non-specified cable, please contact your sales representative.

If assembly process is done by jigs & tools which are not identified by Hirose, assurance will not be given.

If considering usage for below mentioned applications, please contact your sales representative.

In cases where the application will demand a high level of reliability, such as automotive, medical instruments, public infrastructure, aerospace/ defense etc. Hirose must review before assurance of reliability can be given.