

# Protect IGBTs by Sensing Current Using Optical Isolation Amplifiers

## White Paper

By Hong Lei Chen, *Product Manager, Avago Technologies*

### Abstract

Insulated-gate bipolar transistors (IGBTs) require full protection to avoid damage and failures resulting from conditions such as short circuits, overloads and overvoltages. The protection is key to ensuring safe and stable power-converter operations in applications such as motor drives and solar and wind power generation systems. To detect over-current and overload conditions, isolation amplifiers featuring fast response or fast fault feedback can be used on the output phases and the DC bus.

### Introduction

Figure 1a shows a typical block diagram of a power converter in an AC motor drive. It consists of an inverter that converts the DC bus voltage to AC power at a variable frequency to drive the motor. IGBTs are expensive power switches that form the heart of the inverter. These power devices must operate at a high frequency and must be able to withstand high voltages.

Isolation amplifiers (iso-amps), such as the ACPL-C79A<sup>[1]</sup> shown in Figure 1b (see inset), work in conjunction with shunt resistors to provide accurate current measurements in power converters even in the presence of high switching noise. When used with a resistive divider, iso-amps work as precision voltage sensors to monitor the DC bus voltage. The current and voltage information from the iso-amps are collected by the microcontroller, which uses the data to calculate the feedback values and output signals needed to provide effective control and fault management in the power converters.

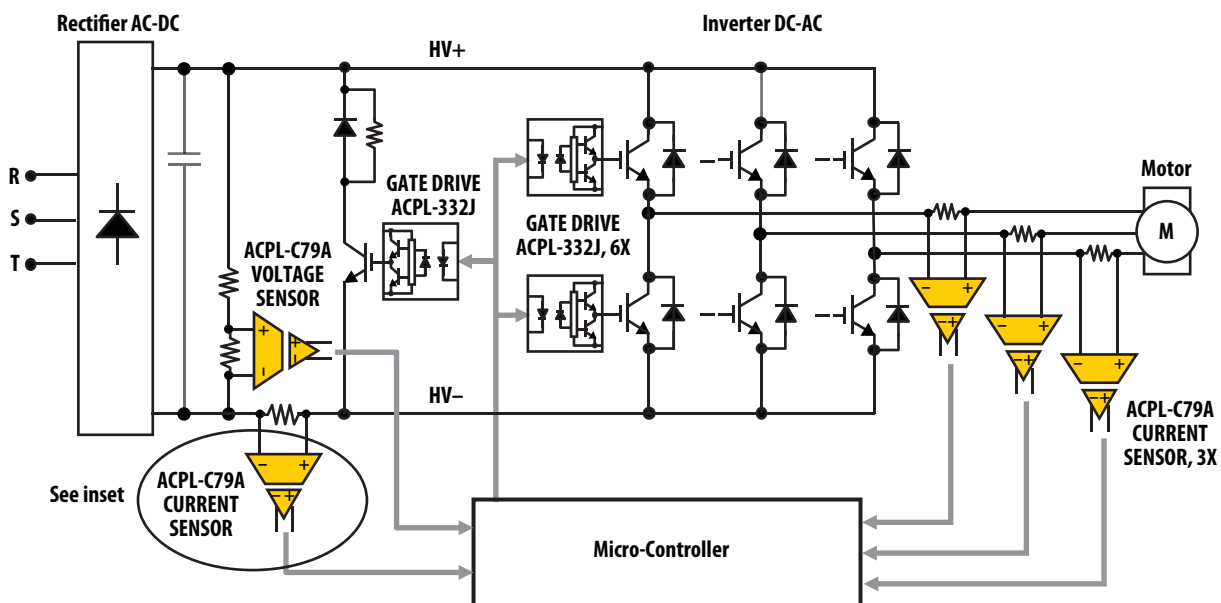

Figure 1a. Block diagram of power converter in a motor drive.

## Fault Protection Requirements

In an inverter, the IGBTs are the most costly components and it thus makes sense to provide as much protection as possible to protect them from damage. The Avago iso-amps provide quick sensing of fault conditions and the algorithms the microcontroller executes can prevent the fault conditions from causing the IGBTs to fail. Additionally, the optical isolation in the iso-amps prevents the fault conditions from overloading the microcontroller and causing it to fail.

However, the IGBT protection must be cost effective – the market continues to demand sufficient IGBT protection from fault conditions at a cost that does not significantly affect the total cost of the motor drive system. To meet this demand, IGBT gate drivers (such as the ACPL-332J<sup>[1]</sup>) and current sensors with protection features have been introduced to carry out essential fault detection in addition to their driving and sensing functions. These products provide a cost-effective scheme to implement IGBT protection and eliminate the need for separate detection and feedback components. Refer to References<sup>[2, 3]</sup> for details of those protection features integrated with the Avago gate drivers and how to use those features in IGBT protection applications. The remainder of this paper will focus on some of the fault protection functions that can be implemented with current/voltage sensors as listed in Table 1.

## Over-Current Detection

Over-current conditions in an IGBT can occur due to a phase-to-phase short, a ground short or a shoot through. The shunt + iso-amp current sensing devices on the output phases and DC bus provide fault detection in addition to current measurement (see Figure 1). Typical IGBT short-circuit survival times are rated up to 10  $\mu\text{s}$ <sup>[4, 5]</sup>. To ensure effective protection, this limit should not be exceeded. Within this limit, the fault must be detected, fed back to controller and the shutdown procedure completed within this period. To achieve this requirement, iso-amps use different methods.

For instance, the ACPL-C79A has a fast, 1.6  $\mu\text{s}$  response time for a step input. That allows the iso-amp to capture transients during short-circuit and overload conditions (see Figure 2)<sup>[6]</sup>. The signal propagation delay from input to output at mid point is only 2  $\mu\text{s}$ , while it takes just 2.6  $\mu\text{s}$  for the output signal to catch up with input, reaching 90% of the final levels.

Besides fast response time, the ACPL-C79A provides  $\pm 1\%$  gain accuracy, excellent nonlinearity of 0.05% and a signal-to-noise ratio (SNR) of 60 dB. Also available are the ACPL-C79B, which offers a higher-precision gain accuracy of  $\pm 0.5\%$ , and the ACPL-C790, which has a  $\pm 3\%$  gain tolerance. All devices in the ACPL-C79A family are certified to withstand a 1230  $V_{\text{peak}}$  working insulation voltage, and can reject high common-mode transient noise of up to 15  $\text{kV}/\mu\text{s}$ . These features are delivered in a stretched SO-8 package that has a footprint 30% smaller than the standard DIP-8 package.

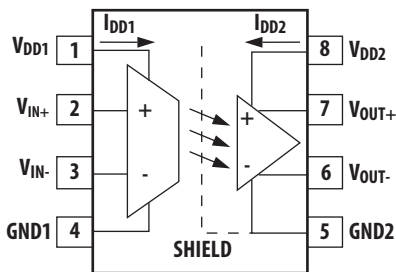

Figure 1b. (inset) Simplified diagram of the ACPL-C79A isolation amplifier.

Table 1. Fault-protection conditions and issues

Condition	Possible Cause	Potential Damage	Protection Feature
Over-current	Phase-to-phase short circuit, ground short, shoot through	Inverter, motor thermal overstress	Current sensor over-current detection
Overloading	Motor stalling, overloading	Inverter, motor over heating	Current sensor overload detection
DC bus overvoltage	Regenerative current flow generates high surge voltage	Power devices and other components	Use iso-amp as voltage sensor to monitor DC bus voltage

Another example is Avago's HCPL-788J, which takes a different approach to achieve fast response in over-current detection (Figure 3)[7,8]. In addition to the signal output pin, it comes with a Fault pin that toggles quickly from High to Low level to indicate an over-current condition. This iso-amp provides  $\pm 3\%$  measurement accuracy.

In the fault feedback design, one issue that the design must deal with is nuisance tripping. Nuisance tripping is a false triggering of the fault detection in the absence of any apparent fault condition that will damage the IGBTs. To avoid false triggering, the HCPL-788J employs a pulse discriminator circuit to effectively blank out the influence of the di/dt and dv/dt glitches. The advantage of this method is that the rejection is independent of amplitude, which means the fault threshold can be set to a much lower level without increasing the risk of nuisance tripping.

In the circuit implementation to achieve the fast fault detection, two comparators in the Fault Detection block are used to detect the negative and positive fault thresholds. The switching threshold is equal to the sigma-delta modulator reference of 256 mV. The outputs of these comparators are connected to blanking filters with a blanking period of 2  $\mu\text{s}$ , and then sent to the Encoder block.

To ensure that the fault status is transmitted across the isolation boundary as quickly as possible, two unique digital coding sequences are used to represent the fault condition, one code for the negative level, one for the positive. When a fault is detected, the normal data transfer through the optical channel is interrupted and the bit stream replaced with the fault code. These two fault codes deviate significantly from the normal coding scheme, so on the detector side, the decoder immediately recognizes the codes as fault conditions[8].

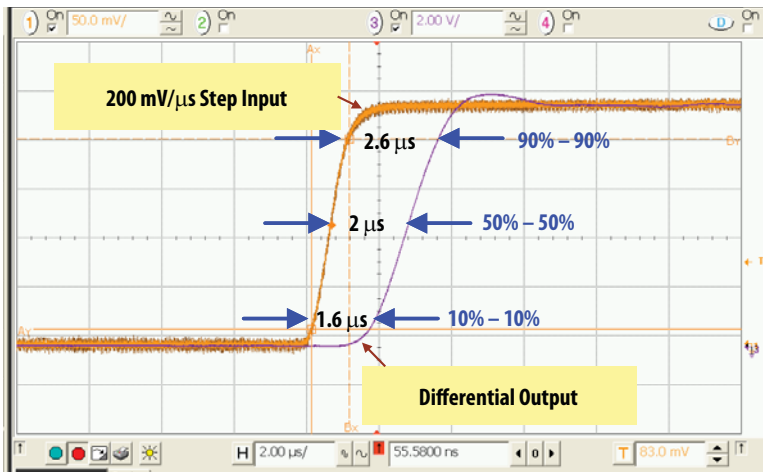

Figure 2. The ACPL-C79A with 1.6  $\mu\text{s}$  fast transient response tracks overload and short circuit current.

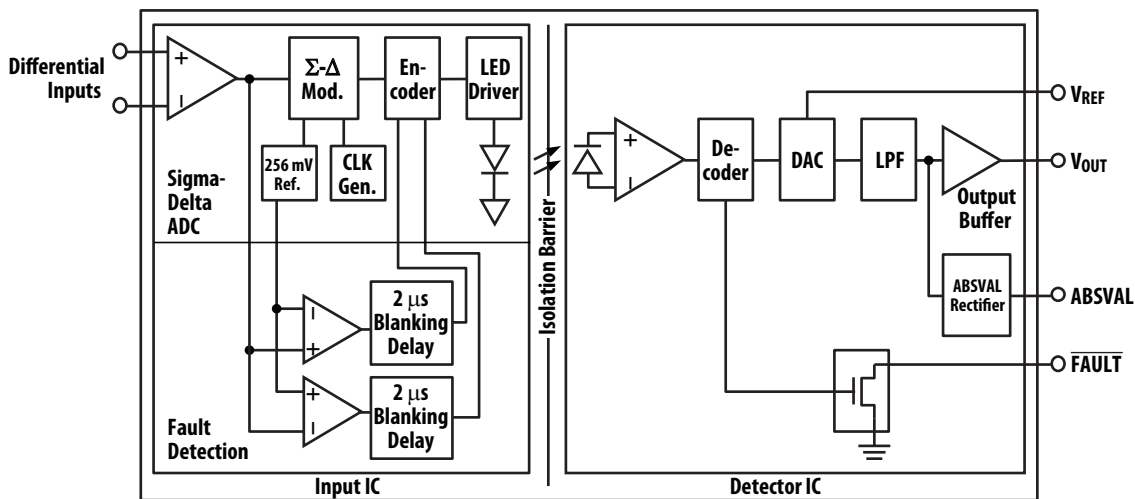

Figure 3. In the HCPL-788J iso-amp, the differential input voltage is digitally encoded by a sigma-delta a-d converter and then fed to the LED driver, which sends the data across the isolation barrier to a detector and d-a converter that transforms the data back to a voltage and a fault signal.

The time required by the decoder to detect and communicate the fault condition across the isolation boundary is around  $1 \mu\text{s}$ . Adding the anti-aliasing filter delay of  $400 \text{ ns}$  gives propagation delay of  $1.4 \mu\text{s}$ . The delay between the fault event and the output fault signal is the sum of the propagation delay and the blanking period ( $2 \mu\text{s}$ ), resulting in an overall fault detection time of  $3.4 \mu\text{s}$  (see Figure 4).

The Fault output pin allows fault signals from several devices to be connected together, enabling multiple parts to be wire-ORed together to create a single fault signal (see the upper right portion of Figure 5)<sup>[7]</sup>. This signal may then be used to directly disable the PWM inputs through the controller.

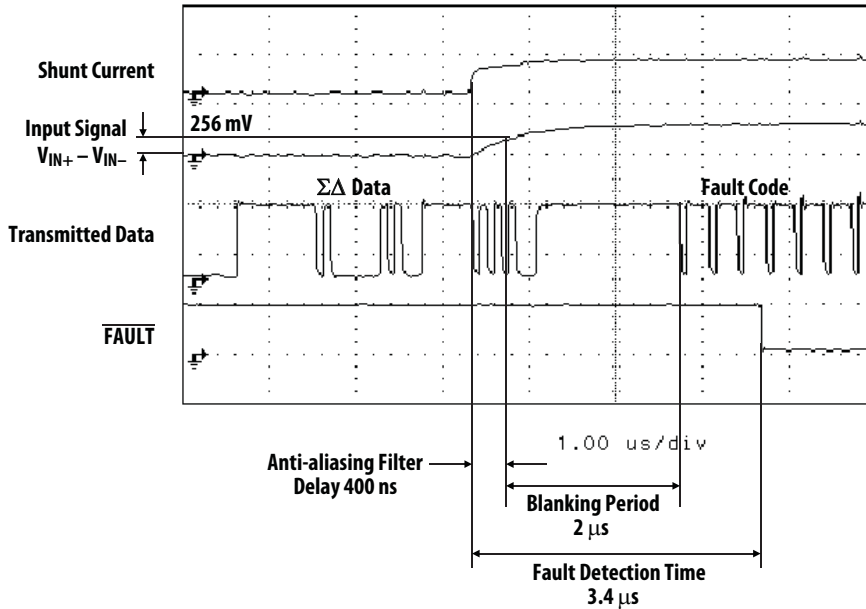

Figure 4. Fault detection timing for the HCPL-788J iso-amp.

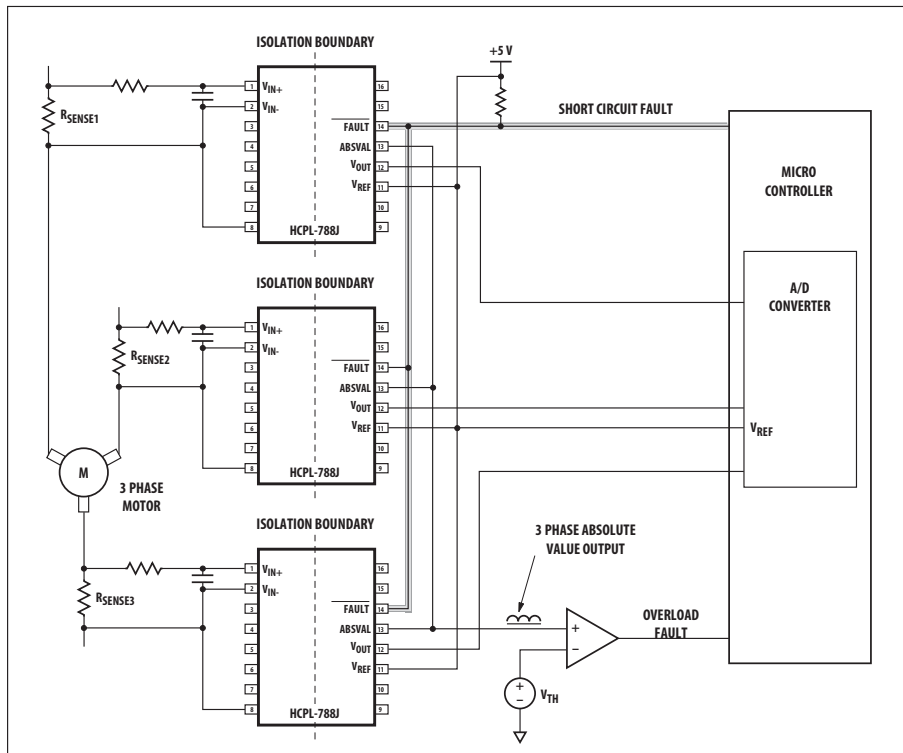

Figure 5. Connection diagram of using HCPL-788J with fault detection signals wire-ORed together.

## Overload Detection

An overload condition refers to a situation where the motor current exceeds the rated current of the drive, but not so far as to put the inverter or motor in immediate danger of failure, e.g. if the motor is mechanically overloaded or a motor stalling situation, as a result of a bearing failure.

Inverters are usually specified with an overload rating in addition to the nominal rating. The time period of the allowable overload rating is dependent on the interval of time before the problem of overheating becomes an issue. A typical overload rating is 150% of nominal load for a period up to one minute.

The Avago ACPL-C79A accepts full scale input range of  $\pm 300$  mV and the data-sheet specifications are based on  $\pm 200$  mV nominal input range. A designer has the flexibility to choose the overload threshold at either of the two figures, or in between. If the measurement accuracy of the overload current is less stringent compared to that of the normal operating current, which is usually the case, setting the threshold near 300 mV is a good choice as this allows full use of the iso-amp's dynamic input range. However, setting the threshold at 200 mV ensures measurement accuracy of the overload current. Once the voltage levels are decided, the designer needs to choose appropriate sense resistor value according to corresponding current level.

The Avago HCPL-788J includes an additional feature, the ABSVAL output, which can be used to simplify the overload detection circuit. The ABSVAL circuit rectifies the output signal, providing an output signal proportional to the absolute level of the input signal according to the formula:

$$ABSVAL = |V_{IN}| \times \frac{V_{REF\ EXT}}{252\ mV}$$

This output is also wire OR-able. When three sinusoidal motor phases are combined, the rectified output (ABSVAL) is essentially a DC signal representing the RMS motor current. This DC signal and a threshold comparator can indicate motor overload conditions before damage to the motor or drive occurs (see the lower right portion of Figure 5).

## Overvoltage Detection

The DC bus voltage must also be continuously kept under control. Under certain operating conditions, a motor can act as a generator, delivering a high voltage back into the DC bus through the inverter's power device and/or the recovery diodes. This high voltage is added to the DC bus voltage and forms a very high surge applied to the IGBTs. That surge may exceed the maximum IGBT collect-emitter voltage and cause damage.

The miniature iso-amp (ACPL-C79A) is often used as a voltage sensor in DC bus monitoring applications (Figure 6). A designer needs to scale down the DC bus voltage to fit the input range of the iso-amp by choosing R1 and R2 values according to appropriate ratio.

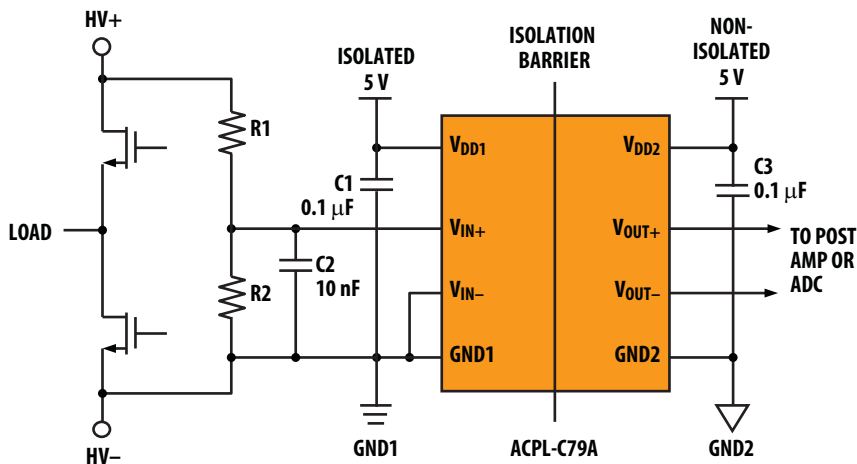

Figure 6. Using the Avago ACPL-C79A for voltage sensing.

## Conclusion

Avago Technologies' isolation amplifiers provide an effective method to protect IGBTs against over-current, overload and overvoltage conditions in addition to their current/voltage sensing function. Using the ACPL-C79A iso-amps together with feature-rich gate drivers such as the ACPL-332J, a cost-effective yet full IGBT protection scheme can be implemented.

## References

1. ACPL-C79A Data Sheet, Avago Technologies, AV02-2460EN.
2. ACPL-332J Data Sheet, Avago Technologies, AV02-0120EN.
3. Hong Lei Chen and Chun Keong Tee, "Using gate drive Optocouplers in IGBT protections," EETimes Europe, December 2010, pp. 28-31.
4. Terje Rogne, "Short-Circuit Capability of IGBT (COMFET) Transistors," IEEE, 1988.
5. J. Li, R. Herzer, R. Annacker, B. Koenig, "Modern IGBT/FWD Chip Sets For 1200 V Applications," Semikron Elektronik GmbH, 2007.
6. ACPL-C79B, ACPL-C79A, ACPL-C790 Precision Miniature Isolation Amplifiers Data Sheet. Avago Technologies, AV02-2460EN.
7. HCPL-788J Data Sheet, Avago Technologies, AV02-1546EN.
8. Patrick Sullivan, Denis Kobasevic, "Smart Current Sensor For Motor Drive Control." PCIM Europe, 1998, Vol. 10 no. 4, pp. 182-186.

For product information and a complete list of distributors, please go to our web site: [www.avagotech.com](http://www.avagotech.com)

Avago, Avago Technologies, and the A logo are trademarks of Avago Technologies in the United States and other countries. Data subject to change. Copyright © 2005-2012 Avago Technologies. All rights reserved.  
AV02-3457EN - April 16, 2012

**AVAGO**  
TECHNOLOGIES