



# AN90024

## Resistor Equipped Transistors (RETs): Key parameters and application insights

Rev. 1.1 — 3 August 2021

application note

### Document information

Information	Content
Keywords	RET, polysilicon resistors, digital transistor, pre-biased transistor
Abstract	This application note explains specific product and application aspects of Resistor Equipped Transistors (RETs)

## 1. Introduction

Bipolar transistors are controlled via the base current applied. Because of high temperature dependency of the voltage drop across the base-emitter path, it is required to add at least a series resistors at the base for stable and safe operation of a transistor in most applications. This is required to keep base current at a desired level.

To reduce the number of components and to make board designs less complex, Resistor-Equipped Transistors (RET) have been introduced. These are single or dual transistors with resistors integrated on the same die. The integrated resistors have higher tolerances than commonly used external resistors. This fact makes RETs most suitable for switching applications where the transistor operates either in on-state or off-state. This is the reason also, why RETs are often referred to as digital transistors.

## 2. RET basics: topologies and nomenclature

RETs are available with NPN and PNP transistors. The most simple resistor configuration is a series resistor applied at the base as shown in [Fig. 1](#). Another option are RETs with a base divider. Then there is a base series resistor R1 integrated and a second resistor R2 in parallel to the base-emitter path.

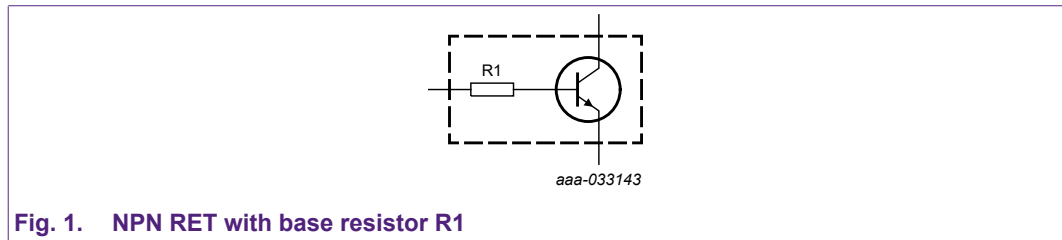

**Fig. 1. NPN RET with base resistor R1**

[Fig. 2](#) shows this topology with the base divider integration of R1 and R2. Both topologies can be found for PNP transistors as well of course.

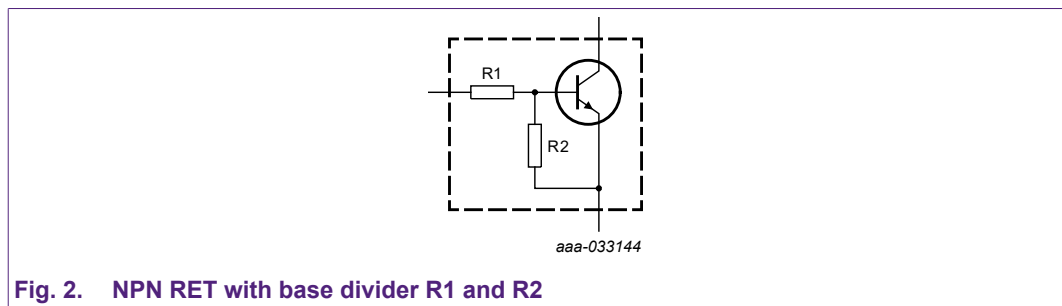

**Fig. 2. NPN RET with base divider R1 and R2**

For R1 the value can be chosen from a list starting at 2.2 k $\Omega$ . Additional options are 4.7 k $\Omega$ , 10 k $\Omega$ , 22 k $\Omega$  and 47 k $\Omega$ . R2 option list starts with 10 k $\Omega$  with the additional choices of 22 k $\Omega$  and 47 k $\Omega$ . For the ratio of the resistors there are several options from R2/R1 equal 1, 2.13, 4.55, 10 and 21.

**Resistor Equipped Transistors (RETs): Key parameters and application insights**

[Table 1](#) explains the nomenclature for single RETs. An example type name is NHDTA124ET which can be decoded with the table below. Most important is the character indicating the Bipolar Junction Transistor (BJT) type and collector current rating. The current clusters are lower or equal higher than 500 mA. The characters A and B stand for PNP device whereas C and D are used for NPN types. For the base resistor network, the series resistor R1 is defined by a base number followed by a multiplier indication number. The character that follows informs the resistor ratio R1/R2. Finally there is a character which tells the package variant. RETs are available in conventional leaded packages such as SOT23 and SOT323 but also in leadless packages like SOT1215 which is a DFN1010 or SOT883 which the same as DFN1006 so a 1 mm x 0.6 mm device.

**Table 1. Nomenclature single RETS**

1 <sup>st</sup> letter Company Indicator	2 <sup>nd</sup> letter Voltage Indicator	2 <sup>nd</sup> 3 <sup>rd</sup> letter	Polarity and Current	1 <sup>st</sup> number	Base number for R1	Multiplier for R1	Resistor Ratio R2/R1	Package Indicator
N = Nexperia	H = high voltage	DT = Digital Transistor	A = PNP, < 500 mA	1 = no meaning	1 = 1	3 = x 10E3	T = R1 only	T = SOT23
P = Philips (legacy)		BR = Low V <sub>CEsat</sub> RET	B = PNP, ≥ 500 mA		2 = 2.2	4 = x 10E4	E = 1 R1 = R2	U = SOT323
			C = NPN, < 500 mA		4 = 4.7	5 = x 10E5	V = 0.213	M = SOT883
			D = NPN, ≥ 500 mA		Comp. only:	Comp. only:	W = 0.46	MB = SOT883B
					3 = 3.3	2 = x 10E2	X = 2.13	QA = SOT1215
					5 = 5.6		Y = 4.55	QC = SOT8009
							Z = 10	QB = SOT8015

[Table 2](#) shows an equivalent table for dual RETs. The naming structure is quite different from the one for single RETs. Very important is the 3<sup>rd</sup> letter which informs the topology of the dual RET, so if two NPNs or PNPs or a complementary pair can be found in the device.

**Table 2. Nomenclature Double RETS**

1 <sup>st</sup> letter Company Indicator	2 <sup>nd</sup> letter Voltage Indicator	Package Indicator	2 <sup>nd</sup> letter	3 <sup>rd</sup> letter	Number(s)
N = Philips (legacy)	H = High voltage	I = SOT457	M = no meaning	B = 2 x PNP	Consecutive numbering
P = Nexperia		U = SOT363		C = NPN/ PNP ≥ 500 mA	
		E = SOT666		D = NPN/PNP	
		Q = SOT1216		H = 2 x NPN	
		R = SOT1268		N = 2 x NPN >0 = 500 mA	
				P = 2 x PNP 500 mA	
				T = 2 x PNP	
				X = 2 x NPN	
				Z = NPN/PNP	

### 3. Application Examples

RETs are used as switches mainly, thus in the two states “on” and “off”. This is why they are referred to as digital transistors often. A basic example is shown in schematic diagram in using an NPN-RET with integrated base series resistor.  $V_1$  is the control voltage and provides the base current for the BJT. If  $V_1$  is below  $V_{off}$  the transistor is turned off.  $V_{out}$  is almost equal to  $V_2$ . Once  $V_1$  reaches the turn-on level, base current flows and  $V_{out}$  decreases. The switch changes into the on-state and  $V_{out}$  becomes equal to  $V_{CEsat}$ .

The circuit has the behavior of an inverter with voltage translation.  $V_2$  can be chosen within the datasheet limits of  $V_{CE}$  of the chosen RET. The output voltage swing can be higher and lower than the control voltage  $V_1$ . So voltage translation can be in provided up and down direction.

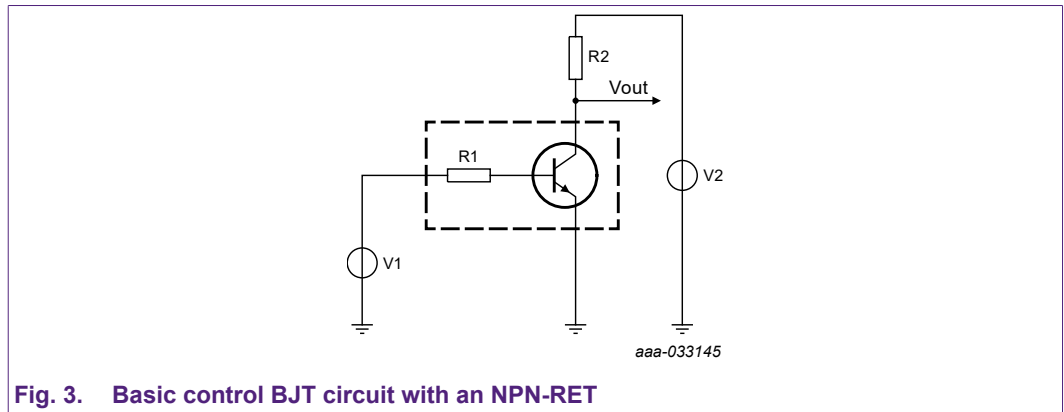

**Fig. 3. Basic control BJT circuit with an NPN-RET**

[Fig. 4](#) is the equivalent circuit created with a PNP-RET. The control voltage  $V_1$  has to be negative against the emitter of  $Q_1$  to get the RET turned on.

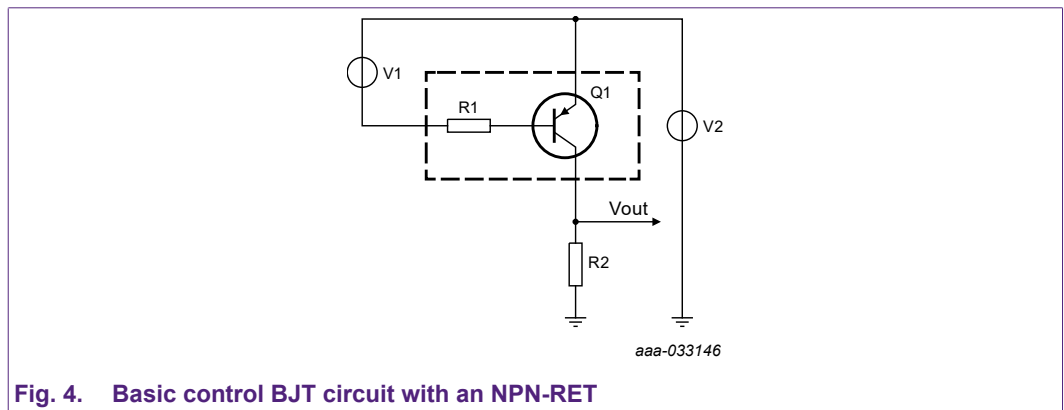

**Fig. 4. Basic control BJT circuit with an NPN-RET**

Resistor Equipped Transistors (RETs): Key parameters and application insights

A very common load switch application with RETs is depicted in Fig. 5. The BJT Q2 switches the load current through the load resistor RL. Q2 conducts if Q1 is turned on. The control RET Q1 requires a positive base voltage to enable the load switch. The topology does not require high base current nor high voltages for the control signal. Q2 can switch higher load voltages in compliance to the rating of the chosen component ( $\leq 80\text{ V}$ ) and also comparably high load currents of up to 500 mA. Low  $V_{CEsat}$  RETs also called **Performance-Based RETs (PBR)**, provide low residual collector-emitter voltages in on-state and therefore achieve high power-efficiency of the load switch. For RET Q2 a product with a base resistor divider achieves a far better turn-off performance compared to a RET with a series resistor in the base-path only. R4 accelerates turn-off time significantly because Q2 is driven by an open-collector stage realized by Q1

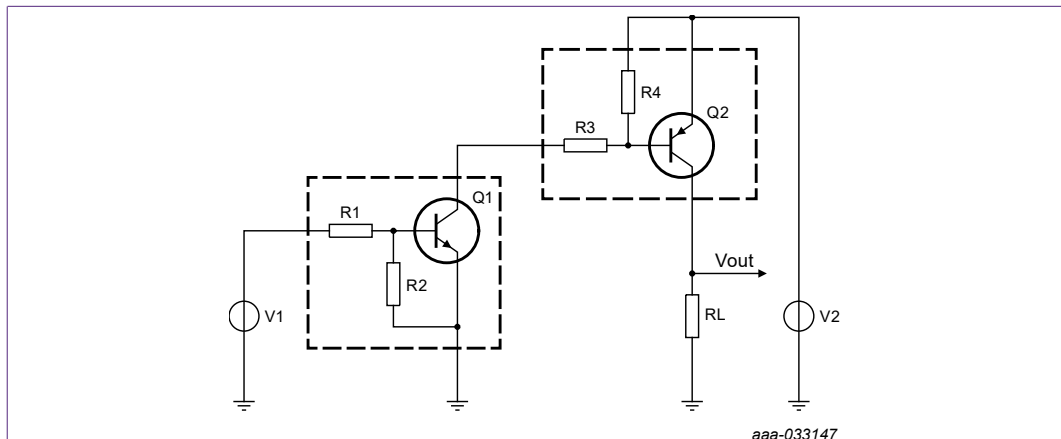

Fig. 5. Load switch with PNP RET in load path and NPN RET in control path

RETs can be used to combine multiple control signals towards one control signal output. Fig. 6 shows two input signals V1 and V2 as base drive for two RETs that share one collector resistor. This circuit behaves like a NOR logic function. If one of the inputs is at a high level or both, the output is providing a low state. Only if both input signals are low the output provides a high-level signal. The advantage of such RET solution against a standard logic gate is that the output can support high voltages up to 80 V that cannot be found for logic families. The input drive can also be designed very flexible via the selection of a suitable base resistor or base voltage divider. If required, the NOR function can be changed into an OR function by adding an inverter stage as shown in Fig. 1 behind the output of the discussed circuit.

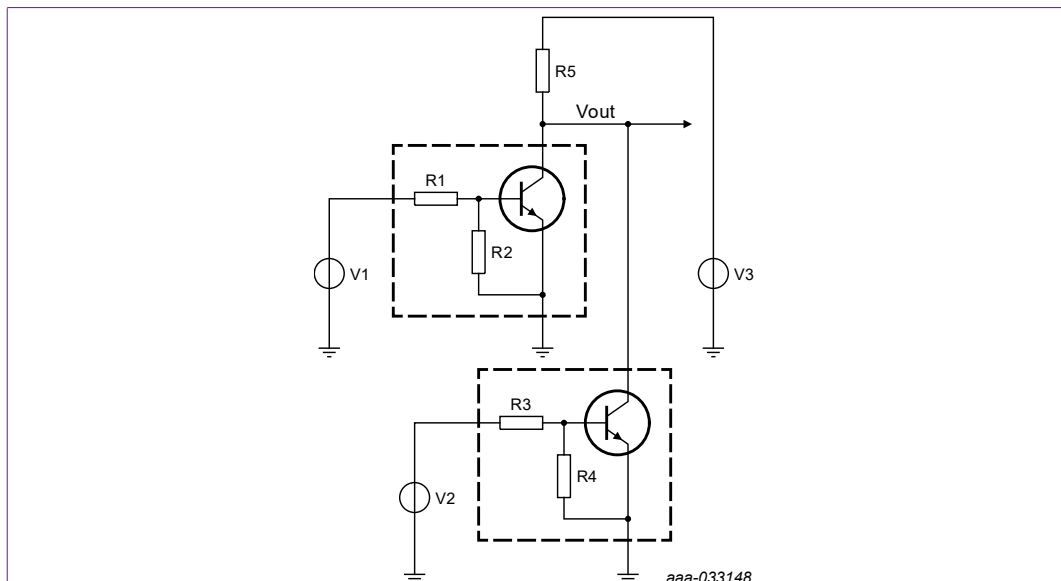
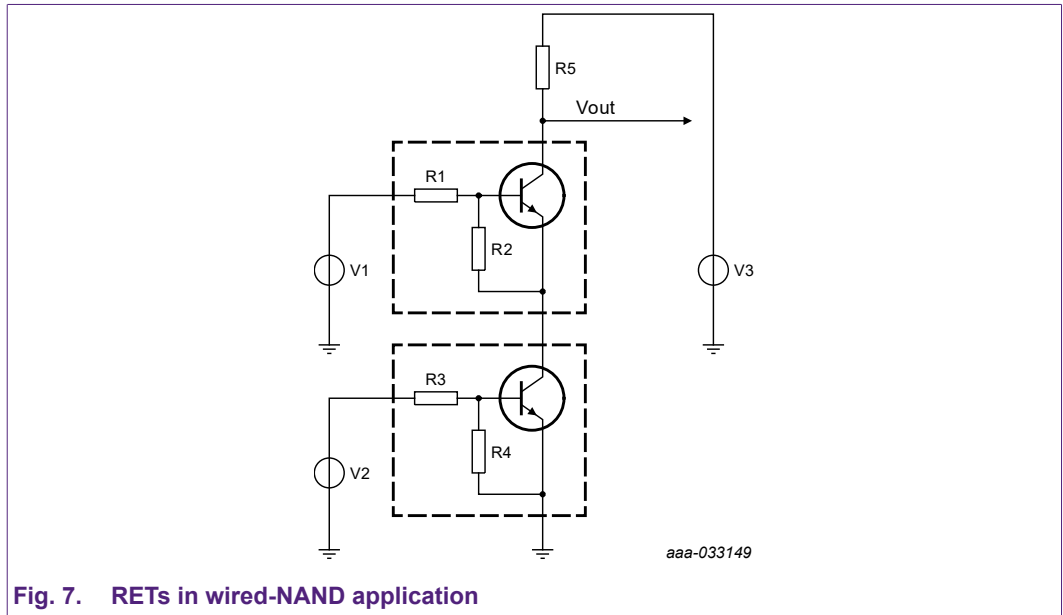

Fig. 6. RETs in wired-NOR application

**Resistor Equipped Transistors (RETs): Key parameters and application insights**

In a similar way, a NAND function can be implemented if RETs are connected in series for the collector-emitter path like shown in Fig. 7. Only if both RETs are turned on at the same time, the output signal  $V_{out}$  provides a low level. If the output is inverted by another RET, an AND function has been created.



**Fig. 7. RETs in wired-NAND application**

In Fig. 8 an application example for a push-pull stage is shown. The circuit is powered by two voltage sources  $V_2$  and  $V_3$ , providing a negative and positive polarity supply.  $V_{out}$  is terminated to ground via  $R_{load}$ , which is the connection between the two voltage sources.  $Q_1$  and  $Q_2$  work as emitter followers and amplify current provided by the input source  $V_1$ .

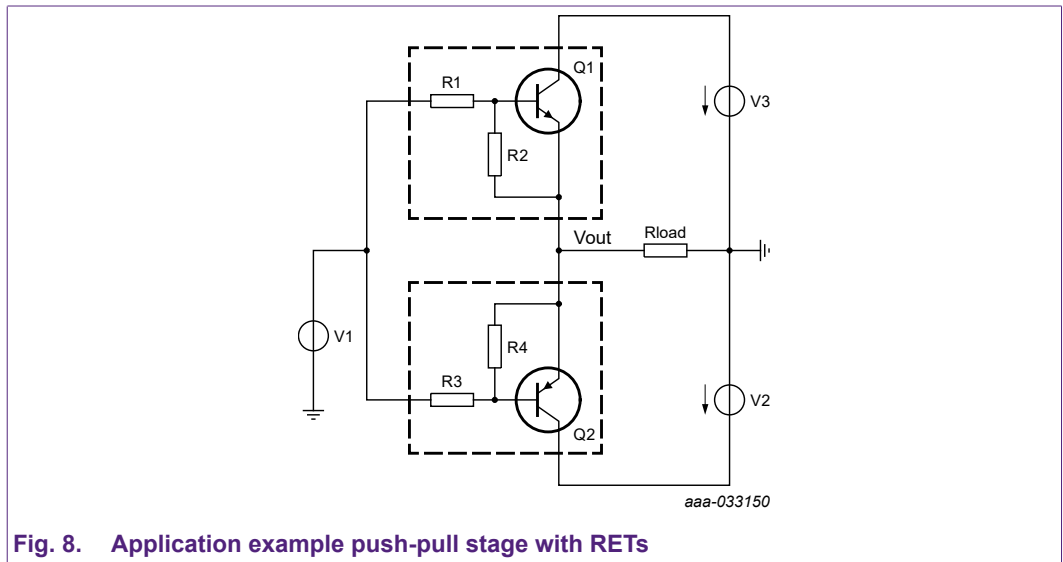

**Fig. 8. Application example push-pull stage with RETs**

## 4. Data sheet parameters

In this chapter the Nexperia data sheets for RETs are explained in detail. The major focus is on the electrical parameters. For the discussion in this chapter a rather new Nexperia high voltage RET has been chosen from an 80 V product series for reference.

The first chapter is the “General Description”. It informs the BJT polarity of the RET and the packages available. [Table 3](#) shows the product overview with the resistor variants R1/R2 of the chosen component. The complementary parts are mentioned if applicable.

**Table 3. Product overview**

Type number	R1	R2	Package		PNP complement:
	kΩ	kΩ	Nexperia	JEITA	
NHDTC114EU	10	10	SOT323	SC-70	NHDTA114EU
NHDTC124EU	22	22			NHDTA124EU
NHDTC144EU	47	47			NHDTA144EU

A list of “Features and benefits” follows in the next section with. The major features like current capability, high break down voltage and automotive qualification are mentioned here.

### Features and benefits

- 100 mA output current capability
- High breakdown voltage
- Built-in resistors
- Simplifies circuit design
- Reduces component count
- Reduces pick and place costs
- AEC-Q101 qualified

The following section informs major application areas, . These are digital or switching applications as discussed in more detail the prior chapter.

### Applications

- Digital applications
- Cost saving alternative for BC846 series in digital applications
- Controlling IC inputs
- Switching loads

“Quick reference data” are depicted in a brief table with electrical key parameters such as maximum allowed  $V_{CE0}$  and output current  $I_O$ .

**Table 4. Quick reference data**

$T_{amb} = 25\text{ °C}$  unless otherwise specified.

Symbol	Parameter	Conditions	Min	Typ	Max	Unit
$V_{CE0}$	collector-emitter voltage	open base	-	-	80	V
$I_O$	output current		-	-	100	mA

## Resistor Equipped Transistors (RETs): Key parameters and application insights

The pinout of the RET is informed with the emitter, collector and input connections as shown below. The input pin is also referred to as base although there are resistors integrated in between.

**Table 5. Pinning**

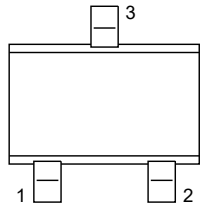
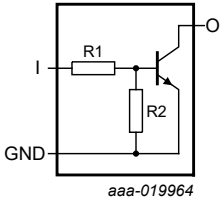
Pin	Symbol	Description	Simplified outline	Graphic symbol
1	I	input (base)		 aaa-019964
2	GND	GND (emitter)		
3	O	output (collector)		

The next section contains the ordering information.

**Table 6. Ordering information**

Type number	Package		
	Name	Description	Version
NHDTTC114EU	SC-70	plastic surface-mounted package; 3 leads	SOT323
NHDTTC124EU			
NHDTTC144EU			

The marking table in informs the marking of the devices. The last character “%” is a placeholder for the manufacturing site.

**Table 7. Marking**

Type number	Marking code [1]
NHDTTC114EU	5M%
NHDTTC124EU	5Q%
NHDTTC144EU	5S%

[1] % = placeholder for manufacturing site code



## Resistor Equipped Transistors (RETs): Key parameters and application insights

The limiting values follow in the next section of the RET data sheet in [Table 8](#).

$V_{CB0}$  is the maximum collector-base voltage with an open emitter pin.  $V_{CE0}$  is the maximum allowed collector-emitter voltage with an open base. For a RET where a resistor is placed between base and emitter it could be called  $V_{CER}$  as well because the input of the RET is open, but not the base of the BJT. There is the relation to be considered for the breakdown voltage of the collector-emitter path of a BJT as shown below:

$$V_{CES} \geq V_{CER} \geq V_{CE0}$$

$V_{CES}$  is tested with the base being short-circuit to the emitter. For RETs the integrated resistors are not taken into account for the nomenclature of parameters. Despite of integrated resistors the term  $V_{CE0}$  is used still. This is important to be taken into account for other key parameters as well like leakage current ratings.

$V_I$  has a maximum rating of 10 V for the example data sheet of a PNP RET with a divider ratio of 1. The BJT as a stand-alone device would have the limitation of  $V_{EBO} = 5$  V. Due to the input divider this value is doubled. The base-emitter diode is driven reverse and therefore does not conduct below the limit value. For further details please refer to chapter 5.

For the other polarity of  $V_I$ , base current flows, so there is a forward voltage drop across the base-emitter diode to be considered whereas the rest of the input voltage is present at the base series resistor R1. The voltage limit is mainly defined by the maximum power dissipation of the integrated resistor R1. Therefore maximum base current is limited by R1 and thus  $V_I$ .

Total power dissipation  $P_{tot}$  is informed for two mounting conditions. One is meant for a single layer FR4-PCB using a standard footprint. The second value is provided for a 4-layer FR4-PCB, where bottom layer and the inside layers are solid copper planes.

**Table 8. Limiting values**

In accordance with the Absolute Maximum Rating System (IEC 60134).

$T_{amb} = 25$  °C unless otherwise specified.

Symbol	Parameter	Conditions	Min	Max	Unit	
$V_{CB0}$	collector-base voltage	open emitter	-	80	V	
$V_{CE0}$	collector-emitter voltage	open base	-	80	V	
$V_{EBO}$	emitter-base voltage	open collector	-	10	V	
$V_I$	input voltage					
	NHDTC114EU		-10	+40	V	
	NHDTC124EU		-10	+60	V	
	NHDTC144EU		-10	+80	V	
$I_O$	output current		-	100	mA	
$P_{tot}$	total power dissipation	$T_{amb} \leq 25$ °C	[1]	-	235	mW
			[2]	-	315	mW
$T_j$	junction temperature		-	150	°C	
$T_{amb}$	ambient temperature		-55	150	°C	
$T_{stg}$	storage temperature		-65	150	°C	

[1] Device mounted on an FR4 Printed-Circuit-Board (PCB); single-sided copper; tin-plated and standard footprint.

[2] Device mounted on an FR4 Printed-Circuit-Board (PCB); 4-layer copper; tin-plated and standard footprint.

The maximum junction temperature for gold wire products is 150°C because otherwise the alumina layer of the bond wire joint would be consumed up by diffusion processes of the alumina into the gold. For longer exposure to temperatures above 150°C the wire joint becomes unstable and can fail. Copper wire products can be specified up to 175°C. Storage and ambient temperature have the same limits. With rising ambient temperature the maximum power that can be applied degrades with a linear curve as shown in [Fig. 9](#) below. A RET which is designed for  $T_j(\max) = 175$ °C has a derating curve which reaches the x-axis at 175°C, so higher power can be dissipated comparably.

Resistor Equipped Transistors (RETs): Key parameters and application insights

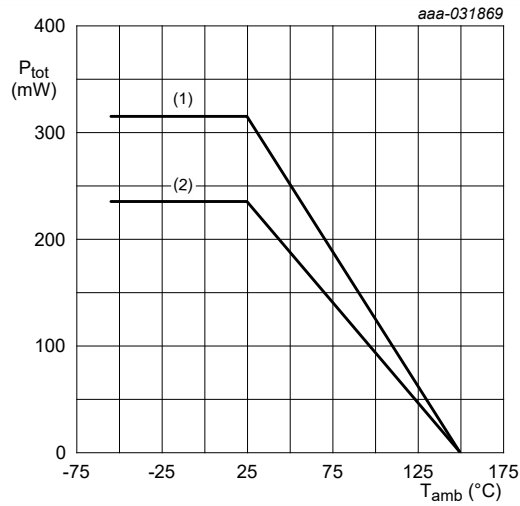

- (1) FR4 PCB, 4-layer copper, standard footprint
- (2) FR4 PCB, single-sided copper, standard footprint

Fig. 9. Power derating curves SOT323 (SC-70)

## Resistor Equipped Transistors (RETs): Key parameters and application insights

Further thermal characteristics are provided in [Table 9](#) in the example RET data sheet. Thermal resistance  $R_{th}$  is informed for different mounting conditions. The values provided could also be calculated from the related  $P_{tot}$  ratings in Tab. 6 with:

$$R_{th(j-a)} = (T_{j(max)} - 25^{\circ}\text{C})/P_{tot}$$

For example for  $R_{th(j-a)}$  the calculation delivers:

$$(150^{\circ}\text{C} - 25^{\circ}\text{C})/0.235\text{ W} = 532\text{ K/W}$$

**Table 9. Thermal characteristics**

$T_{amb} = 25^{\circ}\text{C}$  unless otherwise specified.

Symbol	Parameter	Conditions		Min	Typ	Max	Unit
$R_{th(j-a)}$	thermal resistance from junction to ambient	in free air	[1]	-	-	532	K/W
			[2]	-	-	397	K/W
$R_{th(j-sp)}$	thermal resistance from junction to solder point			-	-	150	K/W

[1] Device mounted on an FR4 Printed-Circuit-Board (PCB); single-sided copper; tin-plated and standard footprint.

[2] Device mounted on an FR4 Printed-Circuit Board (PCB), 4-layer copper, tin-plated and standard footprint.

$R_{th(j-sp)}$  is the thermal resistance from junction to the solder point of the pin for the major thermal path of the SMD package discussed. For RETs in SOT23 or SOT323 this is the collector lead. The other two terminals for the emitter and base are connected via bond wires, so they do not contribute to heat dissipation.  $R_{th(j-a)}$  informs about the thermal resistance from junction to ambient. This value depends significantly on the mounting condition, for example PCB layout and type as well as copper thickness.

$Z_{th(j-a)}$  is the transient thermal impedance from junction to ambient as depicted in Fig.8 and Fig.9. These diagrams help to calculate a thermal scenario for applications where the RET is not run in DC condition but where it operates in switching mode.

The  $Z_{th}$  diagrams are provided for different mounting conditions.  $Z_{th}$  is provided versus the pulse length of the on-state for the RET. Curves are depicted for different duty cycles  $d$  from single events with  $d = 0$  up to DC mode with  $d = 1$ . Duty cycle  $d$  is defined as:

$$d = t_{on} / T, \text{ where } t_{on} \text{ is the on-state duration and } T \text{ the cycle time.}$$

The value for the DC-case is identical to the  $R_{th(j-a)}$  parameter in the data sheet. For long pulses with about more than 10 seconds duration rather small SMD components get heated up to the same temperature like for a constant on-state. This is why all curves start at the same level on the right side of the diagrams. If short pulses are applied, the values for  $Z_{th}$  are becoming smaller, so higher pulse power can be handled. The curves are getting flat for very short pulses and  $d > 0.05$  in the diagram. This is the case because switching frequency is becoming quite high in this region and the heat generation is averaging out in the crystal. There is almost no time for temperature changes between on-state and off-state.

Resistor Equipped Transistors (RETs): Key parameters and application insights

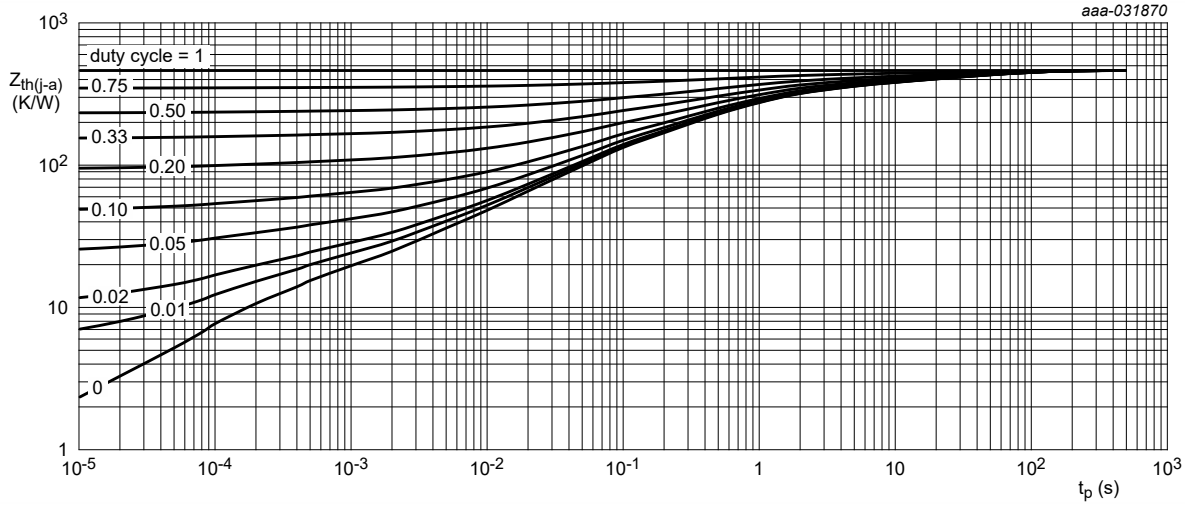

FR4 PCB, single-sided copper, tin-plated and standard footprint

Fig. 10. Transient thermal impedance from junction to ambient as a function of pulse duration; typical values

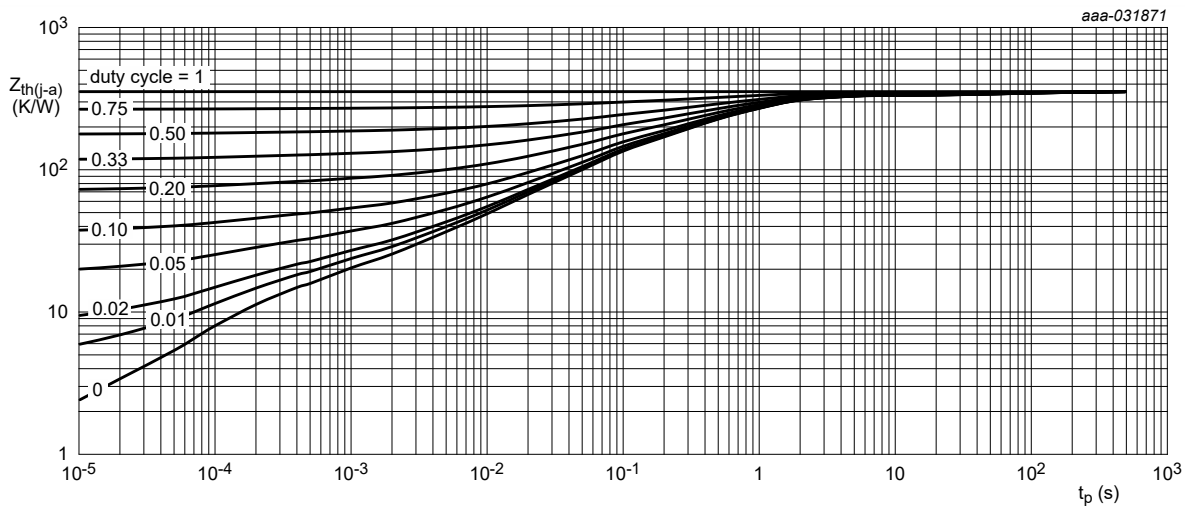

FR4 PCB, 4-layer copper, tin-plated and standard footprint

Fig. 11. Transient thermal impedance from junction to ambient as a function of pulse duration; typical values

Every  $Z_{th}$ -curve is valid for a specific mounting condition. Fig. 10 represents operation with a standard footprint on a single layer FR4 PCB and 35  $\mu\text{m}$  copper layer whereas Fig. 11 is based on a 4-layer FR4 PCB with the RET mounted on a standard footprint. All other three layers of the test PCB are realized as solid copper areas.

If a very good thermal performance of a board design is required it can be recommended to have an extra thermal pad for the collector on the top layer with about 1  $\text{cm}^2$  to improve the thermal path into the second layer. The second layer should provide a bigger copper area in order to get heat spread and dissipated via the PCB.

For calculation of the temperature increase of a RET in an application first the pulse power needs to be derived. The  $Z_{th}$ -curves are valid for rectangular-shaped power pulses. In many applications the shape of the power pulse can deviate from this. Then it is possible in most cases to convert the measured power pulse into a rectangular pulse with an equivalent pulse power.

The correct  $Z_{th}$  value is derived by reading the thermal resistance at the given pulse length  $t_p$  in the curve with the relevant duty cycle. The temperature increase of the junction against ambient temperature is calculated then with:

$$\Delta T = Z_{th(j-a)} * P_p \text{ (} P_p = \text{Pulse Power in Watt)}$$

$T_{amb} + \Delta T$  may not exceed the defined  $T_{j(max)}$  found in the specification.

## Resistor Equipped Transistors (RETs): Key parameters and application insights

The next chapter in data sheets of RETs informs the electrical characteristics of the components. Most characteristics are tested at an ambient temperature of 25° C unless another temperature is informed for the test conditions. If the test condition can heat up the device significantly, the related value is measured in a pulsed test mode in order to avoid self-heating.

Table 10. Characteristics

$T_{amb} = 25\text{ °C}$  unless otherwise specified.

Symbol	Parameter	Conditions	Min	Typ	Max	Unit
$V_{(BR)CBO}$	collector-base breakdown voltage	$I_C = 100\ \mu\text{A}; I_E = 0\ \text{A}$	80	-	-	V
$V_{(BR)CEO}$	collector-emitter breakdown voltage	$I_C = 2\ \text{mA}; I_B = 0\ \text{A}$	80	-	-	V
$I_{CBO}$	collector-base cut-off current	$V_{CB} = 80\ \text{V}; I_E = 0\ \text{A}$	-	-	100	nA
$I_{CEO}$	collector-emitter cut-off current	$V_{CE} = 60\ \text{V}; I_B = 0\ \text{A}$	-	-	100	nA
		$V_{CE} = 60\ \text{V}; I_B = 0\ \text{A}; T_J = 150\text{ °C}$	-	-	5	$\mu\text{A}$
$I_{EBO}$	emitter-base cut-off current					
	NHDTC114EU	$V_{EB} = 7\ \text{V}; I_C = 0\ \text{A}$	-	-	600	$\mu\text{A}$
	NHDTC124EU		-	-	270	$\mu\text{A}$
	NHDTC144EU		-	-	130	$\mu\text{A}$
$h_{FE}$	DC current gain					
	NHDTC114EU	$V_{CE} = 5\ \text{V}; I_C = 10\ \text{mA}$	50	-	-	
	NHDTC124EU		70	-	-	
	NHDTC144EU		100	-	-	
$V_{CEsat}$	collector-emitter saturation voltage	$I_C = 10\ \text{mA}; I_B = 0.5\ \text{mA}$	-	-	100	mV
$V_{I(off)}$	off-state input voltage	$V_{CE} = 5\ \text{V}; I_C = 100\ \mu\text{A}$	-	1.15	0.8	V
$V_{I(on)}$	on-state input voltage					
	NHDTC114EU	$V_{CE} = 0.3\ \text{V}; I_C = 10\ \text{mA}$	2.5	1.8	-	V
	NHDTC124EU		3	2.3	-	V
	NHDTC144EU		5	3.3	-	V
R1	bias resistor 1 (input)	[1]				
	NHDTC114EU		7	10	13	k $\Omega$
	NHDTC124EU		15.4	22	28.6	k $\Omega$
	NHDTC144EU		33	47	61	k $\Omega$
R2/R1	bias resistor ratio	[1]	0.8	1	1.2	
$f_T$	transition frequency	$V_{CE} = 5\ \text{V}; I_C = 10\ \text{mA}; f = 100\ \text{MHz}$	[2]	-	170	MHz
$C_c$	collector capacitance	$V_{CB} = 10\ \text{V}; I_E = i_e = 0\ \text{A}; f = 1\ \text{MHz}$	-	-	2.5	pF

[1] See section "Test information" for resistor calculation and test conditions

[2] Characteristics of built-in transistor

Table 10 starts with the break down voltages  $V_{(BR)CBO}$  and  $V_{(BR)CEO}$ , means break down voltages of the collector-base path with an open emitter respectively collector-emitter path with an open base.

Maximum leakage currents  $I_{CBO}$ ,  $I_{CEO}$  and  $I_{EBO}$  are informed next. These are the cut-off currents for the collector-base, collector emitter and base-emitter path. The emitter-base cut-off current values appear quite high compared to a stand-alone BJT. The reason for this is that the integrated base resistors are located across this path. If an R2 resistor is present, the leakage current is proportional to the sum of R1 and R2 at the specified conditions.

**Resistor Equipped Transistors (RETs): Key parameters and application insights**

The  $h_{FE}$  parameters for RETs are defined as  $I_C/I_{IN}$ .  $I_{IN}$  is divided into the base current and the current which flows through R2 which is  $I_{R2} = V_{BE}/R2$ . Due to this fact  $h_{FE}$  is smaller compared to a RET with a series base resistor R1 only. And of course  $h_{FE}$  is getting smaller the lower the resistance of R2 is, because input current is drained away. This fact can be seen in [Table 10](#) clearly.

$V_{CEsat}$  is the residual collector-emitter voltage in on-state of the RET switch. The test condition is to apply 0.5 mA base drive and 10 mA collector current.

**$V_I$  considerations**

$V_{I(off)}$  informs at which input voltage the RET turns off. The test condition for off-state is to have a collector leakage current of 100  $\mu A$  at a collector-emitter voltage of 5 V. The lower value provided in the table as  $V_{I(off)max}$  has to be considered as maximum allowed output level of the stage which drives the RET. This condition has to be fulfilled for safe off-state of the RET.

For the other direction, the on-state, there is the important parameter  $V_{I(on)min}$  to be considered. The circuit controlling the RET has to provide this voltage for a safe turn on at least. As on-state condition a collector current of 10 mA is defined while the collector-emitter voltage is 0.3 V. The data sheet  $V_I$  rating is valid for the test condition defined only. If a bigger collector current shall be switched the RET requires more base drive voltage  $V_{I(on)}$ .

In [Fig. 12](#) the switching characteristic of a RET is shown with a graph of  $V_{CE}$  versus  $V_I$ .

$V_I < V_{I(off)max}$ : a RET is in off-state for every device shipped.

$V_I < V_{I(off)typ}$ : a typical RET is in off-state.

$V_I > V_{I(on)typ}$ : a typical RET is in on-state.

$V_I > V_{I(on)min}$ : a RET is in on-state for every device shipped.

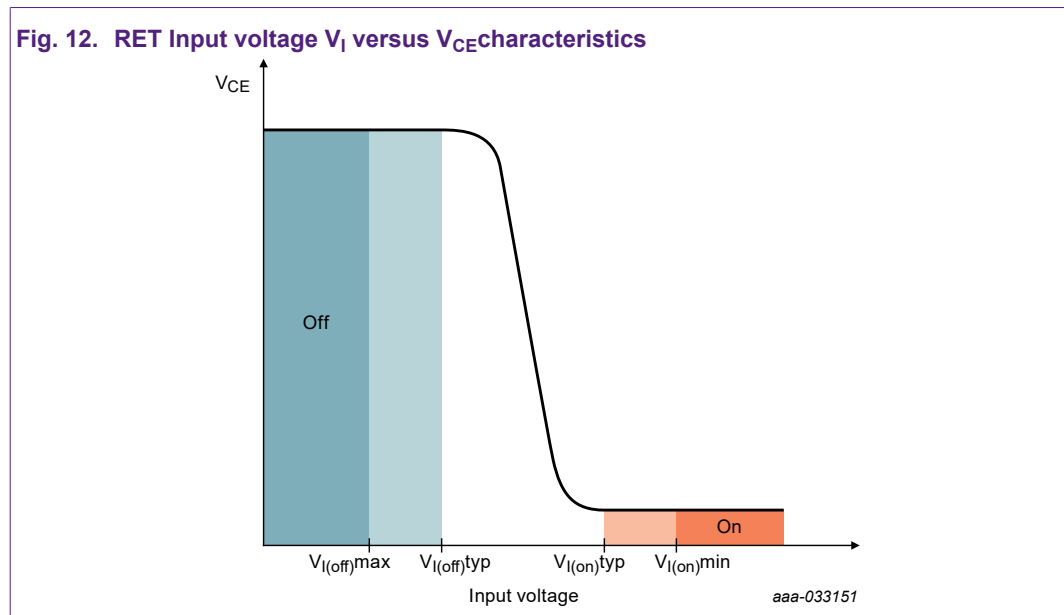

## Resistor Equipped Transistors (RETs): Key parameters and application insights

[Table 11](#) shows the dependency of the on- and off-state input voltages on the resistor divider configuration in RETs from the NHDTc series.

For the  $V_{I(off)}$  condition a very small base current flows into the BJT (about 0.3  $\mu\text{A}$ ). So the typical value to turn off a RET is coupled almost directly to the resistor ratio  $R1/R2$ . It can be calculated with a voltage drop target across  $R2$  or the base-emitter diode where the transistor is turned off. This voltage is about 580 mV for the NHDTc series discussed. Therefore  $V_{I(off)}$  values for a resistor ratio equal 1 show the same voltages (rows 1-3 in [Table 11](#)).

The typical off-state voltages for  $R2$  equal 47 k $\Omega$  and different  $R1$  (2.2 k $\Omega$ , 4.7 k $\Omega$  and 10 k $\Omega$ ) are lower in accordance with the above described background. For  $V_{I(off)}$  max an even value has been defined which safeguards operation in the very left area of [Fig. 12](#).

**Table 11.  $V_{I(on)}$  and  $V_{I(off)}$  dependency on resistor configuration  $R1/R2$**

$R1 / R2$ (k $\Omega$ )	$V_{I(on)}$ min (V)	$V_{I(on)}$ typ (V)	$V_{I(on)}$ max (V)	$V_{I(off)}$ max (V)	RET Type
10 / 10	2.5	1.8	1.15	0.8	NHDTc114ET
22 / 22	3	2.3	1.15	0.8	NHDTc124ET
47 / 47	5	3.3	1.15	0.8	NHDTc144ET
2.2 / 47	1.2	0.81	595	0.5	NHDTc123JT
4.7 / 47	1.4	0.95	625	0.5	NHDTc114YT
10 / 47	1.6	1.22	690	0.5	NHDTc143ZT

The selection of a proper resistor divider option is important so that the control voltage window of the RET fits well to the driving stage. The desired collector or load current has an impact on the base current to be provided for the on-state. For a higher collector current a lower value for  $R1$  and/or less bypass current through  $R2$  is the direction to go.

For an application, temperature drift of the  $V_I$  parameters needs some attention.  $V_{BE}$  of BJTs decreases over temperature with a coefficient of about -1.7 mV/K to -2.1 mV/K dependent on chosen silicon diffusion details.

Current amplification  $h_{FE} = I_C/I_B$  increases with about 1% per Kelvin for a stand-alone BJT.

Resistor Equipped Transistors (RETs): Key parameters and application insights

In Fig. 13 the typical DC current gain as a function of collector current is shown for the ambient temperatures 100 °C, 25 °C and -40 °C. Also for a RET with integrated poly-silicon resistor base divider,  $h_{FE}$  shows higher values the warmer  $T_{amb}$  becomes.

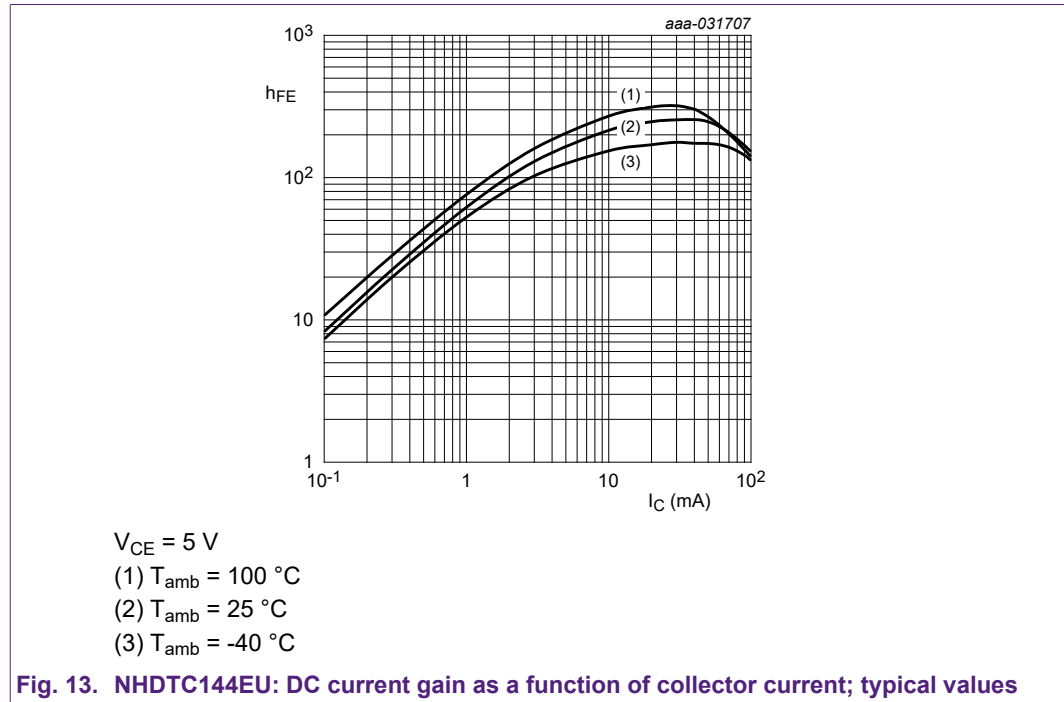

In Fig. 14 of the data sheet, the typical On-state input voltage  $V_{I(on)}$  is shown as a function of  $I_C$ . As to be expected a higher input voltage is required to drive more collector current at same  $V_{CE}$ . A low ambient temperature requires higher input voltage because  $V_{BE}$  increases and  $h_{FE}$  drops. So turning on a RET switch at low temperature is the most critical operating condition for an application and the user has to apply enough input voltage in order to turn on the device properly.

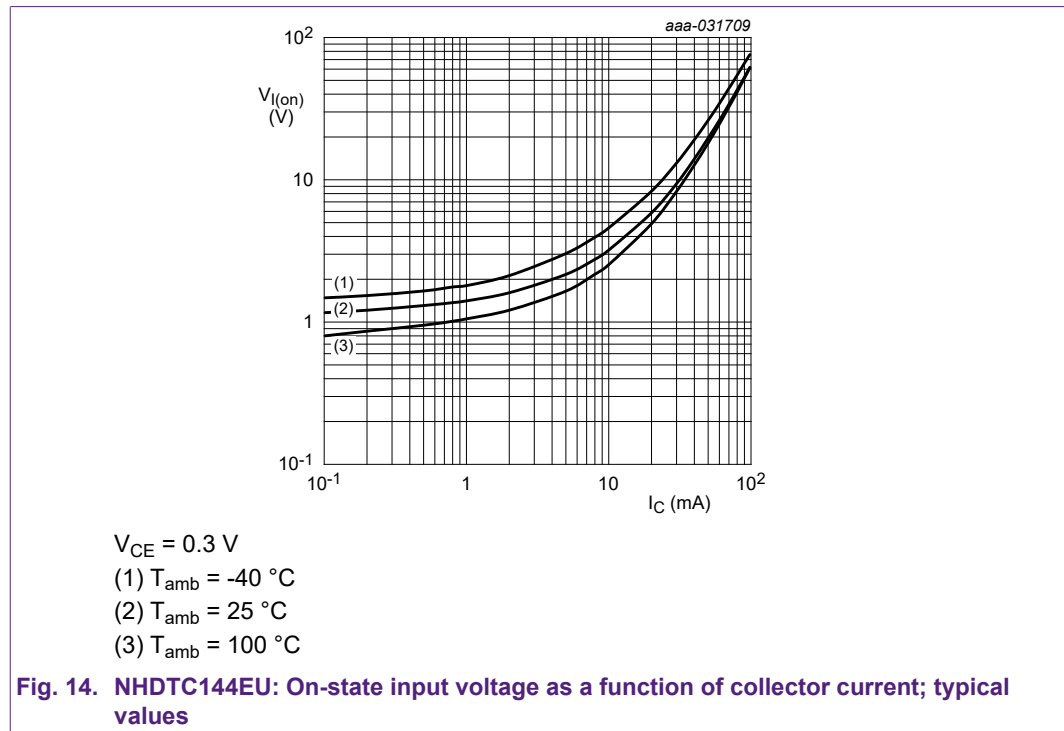



Resistor Equipped Transistors (RETs): Key parameters and application insights

Fig. 15 of the data sheet shows which  $V_{I(off)}$  has to be applied typically to guarantee a safe turn off of a RET switch. For this switching direction the input voltage has to be low enough for safe operation. For the off-state high temperature condition is the most critical scenario. In this case the driver circuit has to be designed in a way that it outputs a voltage well below typical  $V_{I(off)}$  for the highest temperature in the application.

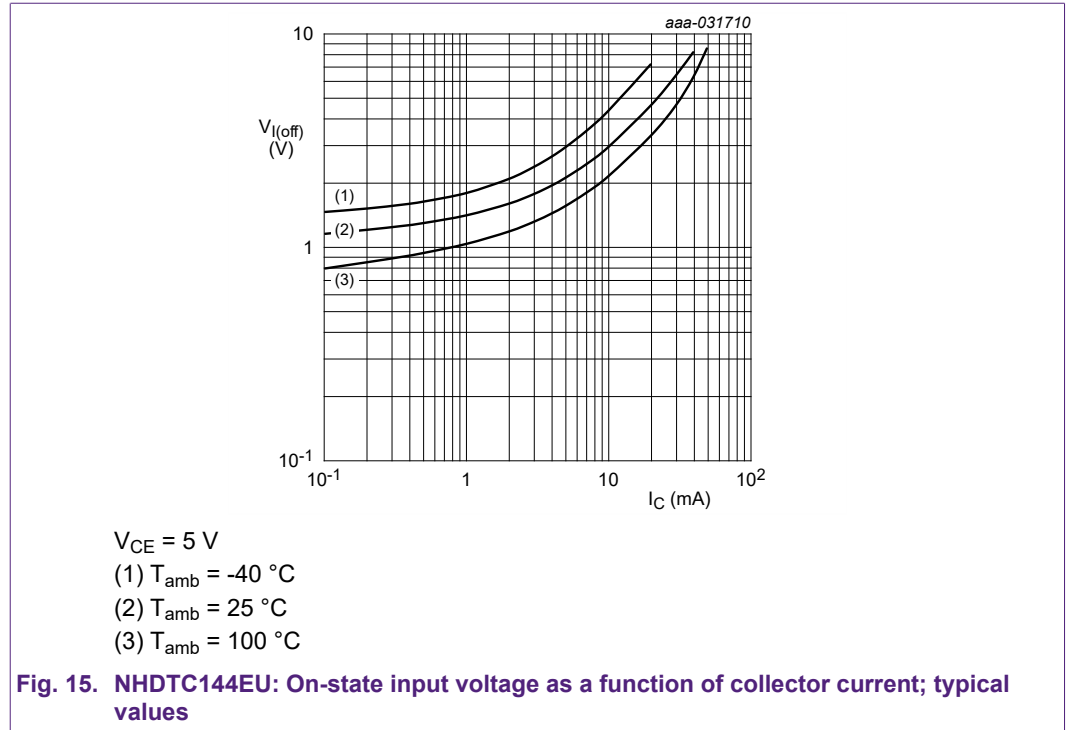

### 5. RET resistor specifics

R1, the series resistor towards the base of the BJT has a tolerance of typically +/- 30 %.

R2 is not defined directly but via a ratio R2/R1. This has a tolerance of ± 20% for 100 mA RETs and ± 10% for 500 mA RETs as depicted in Table 12 below.

**Table 12. Tolerances of integrated resistors in RETs**

Resistor specification	Typical tolerances	RET types
R1	± 30%	all
R2/R1	± 20%	100 mA RETs
	± 10%	500 mA RETs

This means for the range of R1:

$$R1_{min} = 0.7 * R1_{typ}$$

$$R1_{max} = 1.3 * R1_{typ}$$

For calculating the minimum and maximum values of R2, the tolerance for the resistor ratio has to be considered. For 100 mA RETs it can be calculate with ± 20% tolerance according Tab.9:

$$R2_{min} = 0.7 * R1_{typ} * 0.8 * R2_{typ}/R1_{typ} = 0.56 * R2_{typ}$$

$$R2_{max} = 1.3 * R1_{typ} * 1.2 * R2_{typ}/R1_{typ} = 1.56 * R2_{typ}$$

The temperature dependency of the integrated polysilicon resistors can be described with the quadratic equation below. T0 is 25°C for the values provided in Tab. 10.

$$R(T) = R(T_0) * ( 1 + \alpha * (T - T_0) + \beta * (T - T_0)^2)$$

**Resistor Equipped Transistors (RETs): Key parameters and application insights**

Table 13 informs the coefficients  $\alpha$  and  $\beta$  for Phosphorus-doped Poly-Silicon which is used for generation 1 RETs in Nexperia and Boron-doped Poly-Silicon used for generation 2 wafers. Fig. 16 shows the normalized resistance over temperature for these two process options. The resistance of the integrated resistors decreases over temperature. The Boron-doped Poly-Silicon resistor show a smaller temperature dependence compared to the Phosphorus doping.

**Table 13. Coefficients for thermal dependency of Poly-Silicon resistor values in RETs**

	$\alpha$	$\beta$
Phosphorus-doped Poly-Si	-0.00229	7.26 * 10E-6
Boron-doped Poly-Si	-0.00161	3.7275 * 10E-6

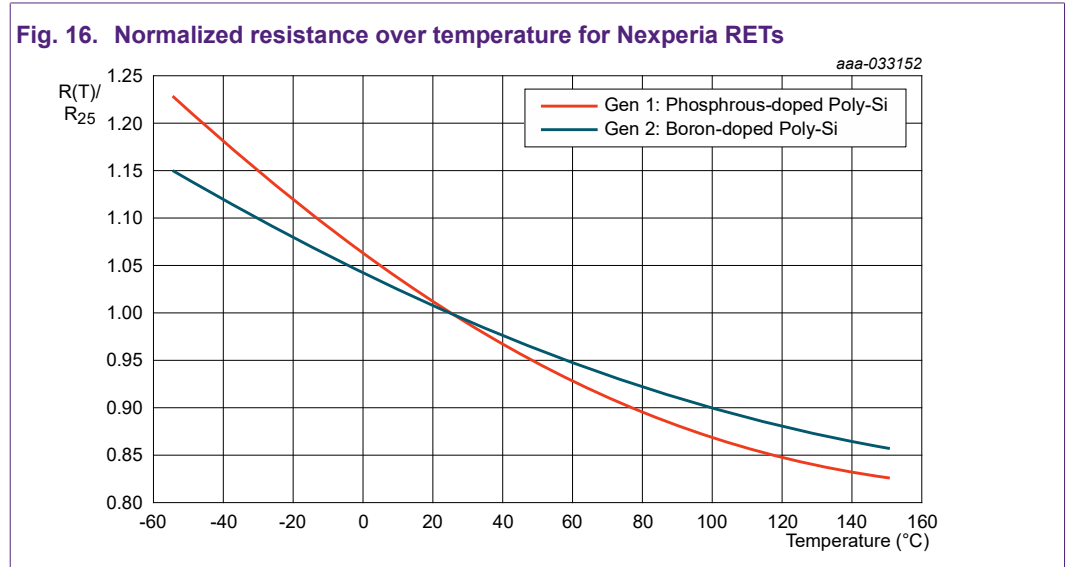

There are two more parameters in RET data sheets, (see Table 10) which are related to the dynamic performance of these components; transition frequency  $f_T$  and collector capacitance  $C_c$ .  $f_T$  is the frequency where the current amplification of the BJT becomes equal to 1 for the test condition defined.

## 6. Testing of RET resistors

The integrated resistors of RETs cannot be tested directly, because there is no access to the node of the base of the BJT. The resistors need to be tested between the contacts 1 and 2 as assigned in Fig. 17. The collector contact is left floating.

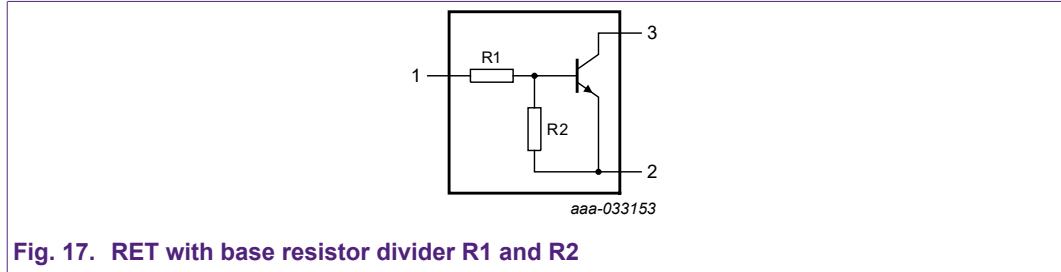

Fig. 17. RET with base resistor divider R1 and R2

For this test set up, an equivalent circuit can be depicted as shown in Fig. 18. The BJT is replaced by a diode  $D_{BE}$  representing the base-emitter path. The integrated resistors of the RET are present with R1 and R2. The related voltages  $V_{BE}$  representing the input voltage of the RET and the voltage drop V1 at R1 respectively V2 at R2 are depicted.

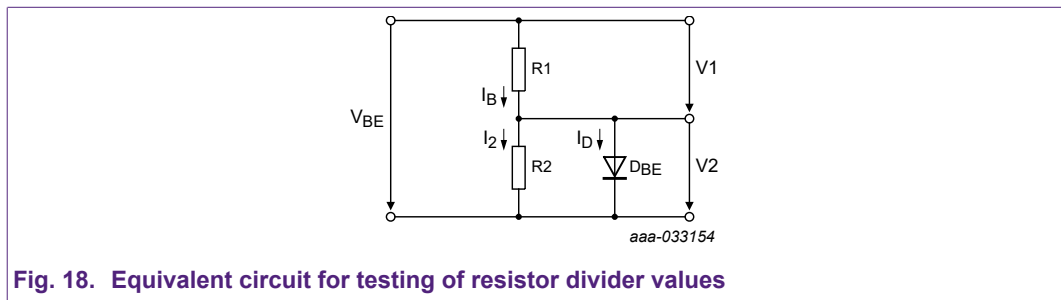

Fig. 18. Equivalent circuit for testing of resistor divider values

Fig. 19 simplifies the circuit further if the polarity of  $V_{BE}$  is taken into account. In case the voltage applied has a positive polarity R2 is much bigger than  $R_{BE}$ , so R2 can be neglected. In reverse direction the base-emitter diode does not conduct, so the resistors themselves dominate the test circuit.

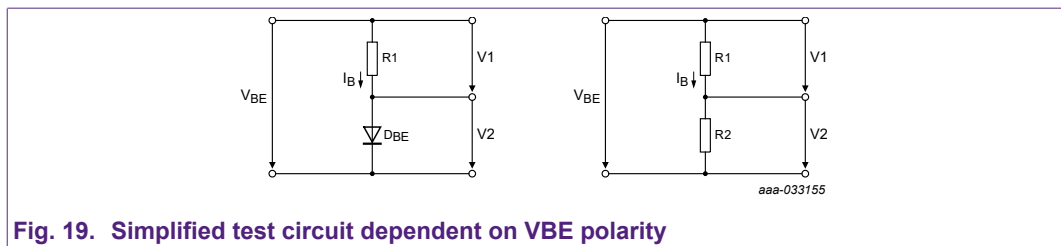

Fig. 19. Simplified test circuit dependent on VBE polarity

Resistor Equipped Transistors (RETs): Key parameters and application insights

Fig. 20 shows an I-V-curve of the base-emitter path, so  $V_{BE}$  versus the input current  $I_B$ , for an NPN-RET with an  $R1$  of 2.2 k $\Omega$  and  $R2$  of 47 k $\Omega$ . The diagram is separated into 4 regions.

Region IV corresponds to reverse direction  $V_{BE}$ , where in addition breakdown voltage of the base-emitter diode is exceeded. The steepness or dynamic resistance  $\Delta V/\Delta I$  in this part of the curve is  $R1$ , because the emitter-base diode clamps to the breakdown voltage.

Region III is the reverse blocking voltage range equivalent to the right part of Fig. 18. The steepness is equivalent to  $R1 + R2$ . This value is tested in mass production under this condition. Nexperia uses a two point testing method for a more exact measurement result, so  $R1 + R2 = \Delta V_{BE}/\Delta I_B$ .

In Region II the  $V_{BE}$  path is biased in forward direction but the base-emitter diode is not conducting significantly yet. The steepness of the curve is proportional to  $R1 + R2$  like for Region III.

In Region I the diode conducts as depicted on the right side of Fig. 18. The curve ramps up with  $R1$  as steepness. To measure the steepness two operating points have to be chosen in order to calculate  $\Delta V_{BE}/\Delta I_B$ .  $R1$  is measured following this test method in mass production. In Region I single operating point measurement would not be sufficient because  $V_f$  of the base-emitter diode creates an voltage offset of the curve that needs to be eliminated for resistor calculation. Fig. 21 shows an example where the two test points provide a good result for  $R1$ , with  $R1 = (V2 - V1) / (I_{B2} - I_{B1})$  as they are in the linear region of the curve.

With the value for  $R1 + R2$  derived from Region III,  $R2$  can be calculated easily and the ratio  $R2/R1$  as well.

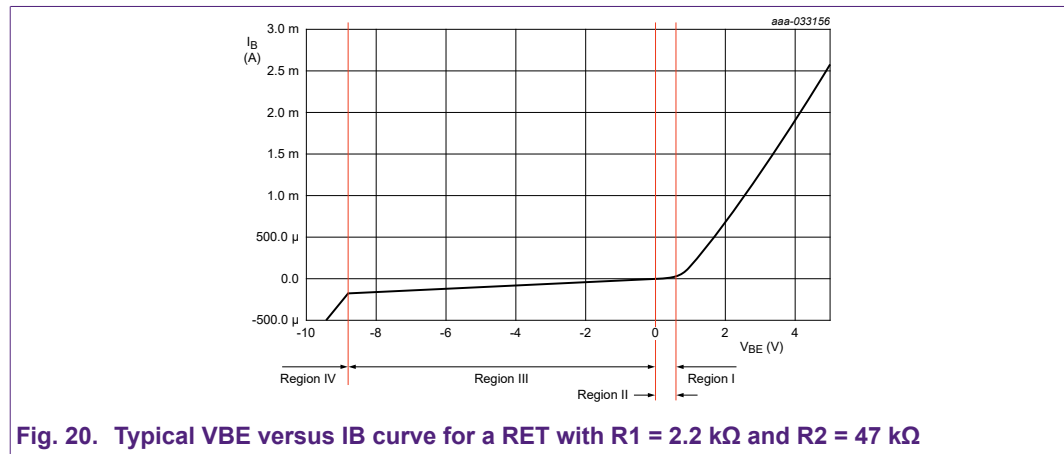

Fig. 20. Typical  $V_{BE}$  versus  $I_B$  curve for a RET with  $R1 = 2.2\text{ k}\Omega$  and  $R2 = 47\text{ k}\Omega$

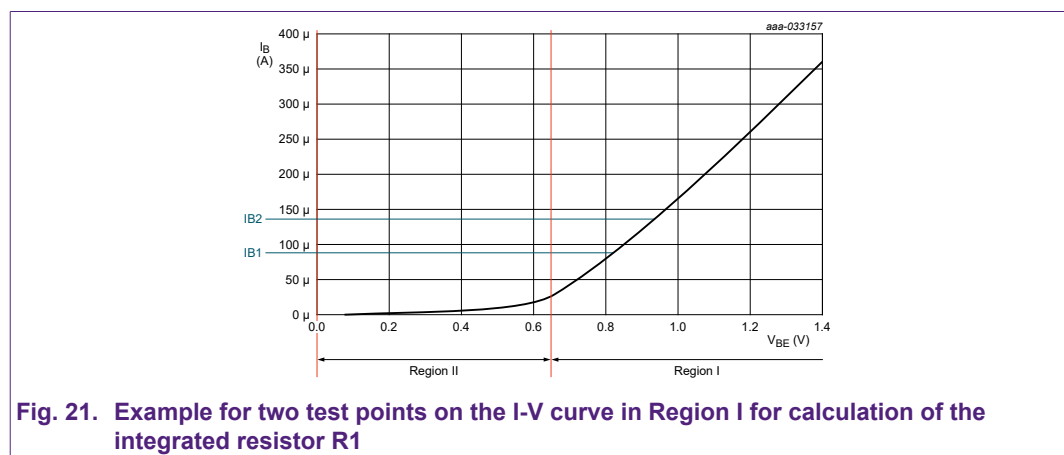

Fig. 21. Example for two test points on the I-V curve in Region I for calculation of the integrated resistor  $R1$

## 7. RETs exposed to ESD events

Bipolar transistors have a rather good ESD robustness compared to small size MOSFET transistors. For MOSFETs the gate is the most vulnerable pin because gate oxide can get damaged quite easily without a recovery from an exposure to surge events above the breakthrough voltage. This is why most small-signal MOSFETs have an integrated gate-source ESD protection nowadays. The ESD robustness level which is targeted for electronic components has the goal to secure safe handling in mounting and board production. A standard level of robustness is a 2 kV HBM (human body model) rating for ICs and discrete electronic components.

Discrete BJTs meet the target of a 2 kV HBM robustness without problems normally because pn-junctions facing a breakdown are not damaged if current and energy applied is comparably low.

In contrast RETs require some attention for ESD events because the integrated poly-silicon resistors tend to be sensitive to surge pulses. This fact is not specific for any semiconductor manufacturer in the market but requires general attention.

ESD damages can be seen at the resistor R1 most often. R2 is protected via the base-emitter diode of the BJT which does either conduct in forward direction or clamps an incoming surge event to a non-destructive level in reverse direction. [Fig. 22](#) shows typical ESD related crystal damages in the base resistor R1.

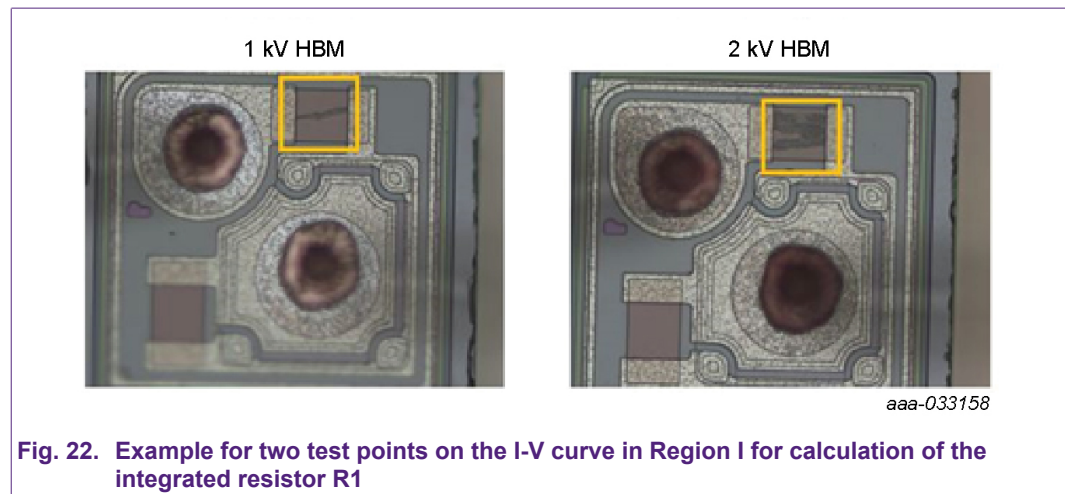

**Fig. 22.** Example for two test points on the I-V curve in Region I for calculation of the integrated resistor R1

In modern ESD-safe manufacturing environment RETs can be mounted safely. If the base is attached to an interface for external connections, an additional external ESD protection might be considered.

## 8. Package overview for Nexperia RETs

Nexperia offers RETs in various package options. [Table 14](#) shows the package types available clustered into leaded and leadless types. The size of the package body is informed as well as the power rating for a standard footprint on a single layer FR4 PCB.

The table shows that leadless packages provide a very good thermal performance while saving board space. A DFN1006 RET performs as well as a much bigger SOT23 device. With a DFN1412-6 RET up to 480 mW can be dissipated with a package area of 1.4 mm x 1.2 mm = 1.68 mm<sup>2</sup> compared to 400 mW for a SOT457 and a much bigger package area of 4.35 mm<sup>2</sup>. The DFN1412 is 40% of the size of a SOT457 for the package body. In a design the occupied area is even more important to be compared. For DFN1412 the occupied area is 1.6 mm x 1.71 mm = 2.736 mm<sup>2</sup>. For SOT457 the area 5.3 mm x 5.05 mm = 26.765 mm<sup>2</sup> needs to be provided on a board. So space saving is enormous for the DFN package as the factor is close to 10. The reason is that the leads itself and the landing pads of a leaded package require significant extra space compared to a leadless device where the landing pads are almost under the package with small areas outside the package body.

The thermal path from the crystal down into the PCB is short and direct. This is why  $R_{th(j-sp)}$  is very small for DFN devices. Leadless packages allow a more compact design combined with a high power density. This helps designers to have a suitable solution for the industry trend towards further miniaturization.

**Table 14. Package options for RETs**

Package cluster	Package name	RET type	Size (mm)	P <sub>tot</sub> (mW) [1]
leaded	SOT23	single	2.9 x 1.3 x 1	250
	SOT323	single	2 x 1.25 x 0.95	235
	SOT457	dual	2.9 x 1.5 x 1	400 (250)
	SOT363	dual	2 x 1.25 x 0.95	350 (235)
	SOT666	dual	1.6 x 1.2 x 0.55	300 (200)
leadless	DFN1006-3 (SOT883)	single	1 x 0.6 x 0.48	250
	DFN1006B-3 (SOT883B)	single	1 x 0.6 x 0.37	250
	DFN1010D-3 (SOT1215)	single	1.1 x 1 x 0.37	325
	DFN1010B-6 (SOT1216)	dual	1.1 x 1 x 0.37	350 (230)
	DFN1412-6 (SOT1268-1)	dual	1.4 x 1.2 x 0.47	480 (325)

[1] For dual types the first value is maximum power per device and the value in brackets is valid per transistor.

## 9. Revision history

Table 15. Revision history

Revision number	Date	Description
1.1	20210803	Minor formatting corrections.
1.0	20210303	AN90024 initial version

## 10. Legal information

### Definitions

**Draft** — The document is a draft version only. The content is still under internal review and subject to formal approval, which may result in modifications or additions. Nexperia does not give any representations or warranties as to the accuracy or completeness of information included herein and shall have no liability for the consequences of use of such information.

### Disclaimers

**Limited warranty and liability** — Information in this document is believed to be accurate and reliable. However, Nexperia does not give any representations or warranties, expressed or implied, as to the accuracy or completeness of such information and shall have no liability for the consequences of use of such information. Nexperia takes no responsibility for the content in this document if provided by an information source outside of Nexperia.

In no event shall Nexperia be liable for any indirect, incidental, punitive, special or consequential damages (including - without limitation - lost profits, lost savings, business interruption, costs related to the removal or replacement of any products or rework charges) whether or not such damages are based on tort (including negligence), warranty, breach of contract or any other legal theory.

Notwithstanding any damages that customer might incur for any reason whatsoever, Nexperia's aggregate and cumulative liability towards customer for the products described herein shall be limited in accordance with the Terms and conditions of commercial sale of Nexperia.

**Right to make changes** — Nexperia reserves the right to make changes to information published in this document, including without limitation specifications and product descriptions, at any time and without notice. This document supersedes and replaces all information supplied prior to the publication hereof.

**Suitability for use** — Nexperia products are not designed, authorized or warranted to be suitable for use in life support, life-critical or safety-critical systems or equipment, nor in applications where failure or malfunction of an Nexperia product can reasonably be expected to result in personal injury, death or severe property or environmental damage. Nexperia and its suppliers accept no liability for inclusion and/or use of Nexperia products in such equipment or applications and therefore such inclusion and/or use is at the customer's own risk.

**Applications** — Applications that are described herein for any of these products are for illustrative purposes only. Nexperia makes no representation or warranty that such applications will be suitable for the specified use without further testing or modification.

Customers are responsible for the design and operation of their applications and products using Nexperia products, and Nexperia accepts no liability for any assistance with applications or customer product design. It is customer's sole responsibility to determine whether the Nexperia product is suitable and fit for the customer's applications and products planned, as well as for the planned application and use of customer's third party customer(s). Customers should provide appropriate design and operating safeguards to minimize the risks associated with their applications and products.

Nexperia does not accept any liability related to any default, damage, costs or problem which is based on any weakness or default in the customer's applications or products, or the application or use by customer's third party customer(s). Customer is responsible for doing all necessary testing for the customer's applications and products using Nexperia products in order to avoid a default of the applications and the products or of the application or use by customer's third party customer(s). Nexperia does not accept any liability in this respect.

**Export control** — This document as well as the item(s) described herein may be subject to export control regulations. Export might require a prior authorization from competent authorities.

**Translations** — A non-English (translated) version of a document is for reference only. The English version shall prevail in case of any discrepancy between the translated and English versions.

### Trademarks

Notice: All referenced brands, product names, service names and trademarks are the property of their respective owners.



## List of Tables

---

Table 1. Nomenclature single RETS.....	3
Table 2. Nomenclature Double RETs.....	3
Table 3. Product overview.....	7
Table 4. Quick reference data.....	7
Table 5. Pinning.....	8
Table 6. Ordering information.....	8
Table 7. Marking.....	8
Table 8. Limiting values.....	9
Table 9. Thermal characteristics.....	11
Table 10. Characteristics.....	13
Table 11. VI(on) and VI(off) dependency on resistor configuration R1/R2.....	15
Table 12. Tolerances of integrated resistors in RETs.....	17
Table 13. Coefficients for thermal dependency of Poly-Silicon resistor values in RETs.....	18
Table 14. Package options for RETs.....	22
Table 15. Revision history.....	23

## List of Figures

Fig. 1. NPN RET with base resistor R1.....	2
Fig. 2. NPN RET with base divider R1 and R2.....	2
Fig. 3. Basic control BJT circuit with an NPN-RET.....	4
Fig. 4. Basic control BJT circuit with an NPN-RET.....	4
Fig. 5. Load switch with PNP RET in load path and NPN RET in control path.....	5
Fig. 6. RETs in wired-NOR application.....	5
Fig. 7. RETs in wired-NAND application.....	6
Fig. 8. Application example push-pull stage with RETs.....	6
Fig. 9. Power derating curves SOT323 (SC-70).....	10
Fig. 10. Transient thermal impedance from junction to ambient as a function of pulse duration; typical values.....	12
Fig. 11. Transient thermal impedance from junction to ambient as a function of pulse duration; typical values.....	12
Fig. 12. RET Input voltage $V_I$ versus $V_{CE}$ characteristics..	14
Fig. 13. NHDTC144EU: DC current gain as a function of collector current; typical values.....	16
Fig. 14. NHDTC144EU: On-state input voltage as a function of collector current; typical values.....	16
Fig. 15. NHDTC144EU: On-state input voltage as a function of collector current; typical values.....	17
Fig. 16. Normalized resistance over temperature for Nexperia RETs.....	18
Fig. 17. RET with base resistor divider R1 and R2.....	19
Fig. 18. Equivalent circuit for testing of resistor divider values.....	19
Fig. 19. Simplified test circuit dependent on $V_{BE}$ polarity..	19
Fig. 20. Typical $V_{BE}$ versus $I_B$ curve for a RET with $R_1 = 2.2 \text{ k}\Omega$ and $R_2 = 47 \text{ k}\Omega$ .....	20
Fig. 21. Example for two test points on the I-V curve in Region I for calculation of the integrated resistor R1.....	20
Fig. 22. Example for two test points on the I-V curve in Region I for calculation of the integrated resistor R1.....	21

## Contents

---

1. Introduction.....	2
2. RET basics: topologies and nomenclature.....	2
3. Application Examples.....	4
4. Data sheet parameters.....	7
5. RET resistor specifics.....	17
6. Testing of RET resistors.....	19
7. RETs exposed to ESD events.....	21
8. Package overview for Nexperia RETs.....	22
9. Revision history.....	23
10. Legal information.....	24

---

© Nexperia B.V. 2021. All rights reserved

For more information, please visit: <http://www.nexperia.com>

For sales office addresses, please send an email to: [salesaddresses@nexperia.com](mailto:salesaddresses@nexperia.com)

Date of release: 3 August 2021

---