

Conductive Polymer Hybrid Aluminum Electrolytic Capacitors

Products Catalog

Hybrid



Guidelines and precautions regarding the technical information and use of our products described in this online catalog.

- If you want to use our products described in this online catalog for applications requiring special qualities or reliability, or for applications where the failure or malfunction of the products may directly jeopardize human life or potentially cause personal injury (e.g. aircraft and aerospace equipment, traffic and transportation equipment, combustion equipment, medical equipment, accident prevention, anti-crime equipment, and/or safety equipment), it is necessary to verify whether the specifications of our products fit to such applications. Please ensure that you will ask and check with our inquiry desk as to whether the specifications of our products fit to such applications use before you use our products.
- The quality and performance of our products as described in this online catalog only apply to our products when used in isolation. Therefore, please ensure you evaluate and verify our products under the specific circumstances in which our products are assembled in your own products and in which our products will actually be used.
- If you use our products in equipment that requires a high degree of reliability, regardless of the application, it is recommended that you set up protection circuits and redundancy circuits in order to ensure safety of your equipment.
- The products and product specifications described in this online catalog are subject to change for improvement without prior notice. Therefore, please be sure to request and confirm the latest product specifications which explain the specifications of our products in detail, before you finalize the design of your applications, purchase, or use our products.
- The technical information in this online catalog provides examples of our products' typical operations and application circuits. We do not guarantee the non-infringement of third party's intellectual property rights and we do not grant any license, right, or interest in our intellectual property.
- If any of our products, product specifications and/or technical information in this online catalog is to be exported or provided to non-residents, the laws and regulations of the exporting country, especially with regard to security and export control, shall be observed.

<Regarding the Certificate of Compliance with the EU RoHS Directive/REACH Regulations>

- The switchover date for compliance with the RoHS Directive/REACH Regulations varies depending on the part number or series of our products.
- When you use the inventory of our products for which it is unclear whether those products are compliant with the RoHS Directive/REACH Regulation, please select "Sales Inquiry" in the website inquiry form and contact us.

We do not take any responsibility for the use of our products outside the scope of the specifications, descriptions, guidelines and precautions described in this online catalog.

Notices

■ Applicable laws and regulations

- This product complies with the RoHS Directive (Restriction of the use of certain hazardous substances in electrical and electronic equipment (DIRECTIVE 2011/65/EU and (EU)2015/863)).
- No Ozone Depleting Chemicals(ODC's), controlled under the Montreal Protocol Agreement, are used in producing this product.
We do not use PBBs or PBDEs as brominated flame retardants.
- Export procedure which followed export related regulations, such as foreign exchange and a foreign trade method, on the occasion of export of this product.
- These products are not dangerous goods on the transportation as identified by UN(United Nations) numbers or UN classification.

■ Limited applications

- This capacitor is designed to be used for electronics circuits such as audio/visual equipment, home appliances, computers and other office equipment, optical equipment, measuring equipment.
- High reliability and safety are required [be / a possibility that incorrect operation of this product may do harm to a human life or property] more. When use is considered by the use, the delivery specifications which suited the use separately need to be exchanged.

■ Intellectual property rights and licenses

- The technical information in this specification provides examples of our products' typical operations and application circuits. We do not guarantee the non-infringement of third party's intellectual property rights and we do not grant any license, right, or interest in our intellectual property.

Items to be observed

■ For specification

- This specification guarantees the quality and performance of the product as individual components. The durability differs depending on the environment and the conditions of usage. Before use, check and evaluate their compatibility with actual conditions when installed in the products. When safety requirements cannot be satisfied in your technical examination, inform us immediately.
- Do not use the products beyond the specifications described in this document.

■ Upon application to products where safety is regarded as important

Install the following systems for a failsafe design to ensure safety if these products are to be used in equipment where a defect in these products may cause the loss of human life or other signification damage, such as damage to vehicles (automobile, train, vessel), traffic lights, medical equipment, aerospace equipment, electric heating appliances, combustion/ gas equipment, rotating rotating equipment, and disaster/crime prevention equipment.

- (1) The system is equipped with a protection circuit and protection device.
- (2) The system is equipped with a redundant circuit or other system to prevent an unsafe status in the event of a single fault.

■ Conditions of use

- Before using the products, carefully check the effects on their quality and performance, and determined whether or not they can be used. These products are designed and manufactured for general-purpose and standard use in general electronic equipment. These products are not intended for use in the following special conditions.
 - (1) In liquid, such as Water, Oil, Chemicals, or Organic solvent.
 - (2) In direct sunlight, outdoors, or in dust.
 - (3) In vapor, such as dew condensation water of resistive element, or water leakage, salty air, or air with a high concentration corrosive gas, such as Cl₂, H₂S, NH₃, SO₂, or NO_x.
 - (4) In an environment where strong static electricity or electromagnetic waves exist.
 - (5) Mounting or placing heat-generating components or inflammables, such as vinyl-coated wires, near these products.
 - (6) Sealing or coating of these products or a printed circuit board on which these products are mounted, with resin and other material.
 - (7) Using solvent, water or water-soluble cleaner for flux cleaning agent after soldering. (In particular, when using water or a water-soluble cleaning agent, be careful not to leave water residues)
 - (8) Using in the atmosphere where strays acid or alkaline.
 - (9) Using in the atmosphere where there are excessive vibration and shock.
- Please arrange circuit design for preventing impulse or transitional voltage. Do not apply voltage, which exceeds the full rated voltage when the capacitors receive impulse voltage, instantaneous high voltage, high pulse voltage etc.
- Our products there is a product are using an electrolyte solution. Therefore, misuse can result in rapid deterioration of characteristics and functions of each product. Electrolyte leakage damages printed circuit and affects performance, characteristics, and functions of customer system.

! Application guidelines (Hybrid)

1. Circuit design

1.1 Operating temperature and frequency

Electrical characteristics of the capacitor are likely to change due to variation in temperature and/or frequency. Circuit designers should take these changes into consideration.

(1) Effects of operating temperature on electrical parameters

At higher temperatures : leakage current and capacitance increase while equivalent series resistance (ESR) decreases.

At lower temperatures : leakage current and capacitance decrease while equivalent series resistance (ESR) increases.

(2) Effects of frequency on electrical parameters

At higher frequencies : capacitance and impedance decrease while tan d increases.

At lower frequencies : heat generated by ripple current will rise due to an increase in equivalent series resistance (ESR).

1.2 Operating temperature and life expectancy

(1) Expected life is affected by operating temperature. Generally, each 10 °C reduction in temperature will double the expected life. Use capacitors at the lowest possible temperature below the upper category temperature.

(2) If operating temperatures exceed the upper category limit, rapid deterioration of electrical parameter will occur and irreversible damage will result.

Check for the maximum capacitor operating temperatures including ambient temperature, internal capacitor temperature rise due to ripple current, and the effects of radiated heat from power transistors, IC's or resistors.

Avoid placing components, which could conduct heat to the capacitor from the back side of the circuit board.

(3) The formula for calculating expected life at lower operating temperatures is as follows ;

$$L_2 = L_1 \times 2^{\frac{T_1 - T_2}{10}}$$

L₁ : Guaranteed life (h) at temperature, T₁ °C

L₂ : Expected life (h) at temperature, T₂ °C

T₁ : Upper category temperature + temperature rise due to rated ripple current (°C)

T₂ : Actual operating temperature, ambient temperature + temperature rise due to ripple current (°C)

(4) Please use according to the lifetime as noted in this specification. Using products beyond end of the lifetime may change characteristics rapidly, short-circuit, operate pressure relief vent, or leak electrolyte.

1.3 Common application conditions to avoid

The following misapplication load conditions will cause rapid deterioration of a capacitor's electrical parameters. In addition, rapid heating and gas generation within the capacitor can occur, causing the pressure relief vent to operate and resultant leakage of electrolyte. Under extreme conditions, explosion and fire ignition could result. The leaked electrolyte is combustible and electrically conductive.

(1) Reverse voltage

DC capacitors have polarity. Therefore, please do not apply the reverse voltage. Verify correct polarity before insertion.

(2) Charge / Discharge applications

Standard capacitors are not suitable for use in repeating charge/discharge applications. For charge/discharge applications, consult us with your actual application condition.

For rush current, please do not exceed 100 A.

(3) ON-OFF circuit

Do not use capacitors in circuit where ON-OFF switching is repeated more than 10000 times/per day.

In case of applying to the theses ON-OFF circuit, consult with us about circuit condition and so on.

(4) Over voltage

Do not apply voltages exceeding the maximum specified rated voltage. Voltages up to the surge voltage rating are acceptable for short periods of time.

Ensure that the sum of the DC voltage and the superimposed AC ripple voltage does not exceed the rated voltage.

(5) Ripple current

Do not apply ripple currents exceeding the maximum specified value. For high ripple current applications, use a capacitor designed for high ripple currents. In addition, consult us if the applied ripple current is to be higher than the maximum specified value. Ensure that rated ripple currents that superimposed on low DC bias voltages do not cause reverse voltage conditions.

Even if it is within a rated ripple current, in case the practical use is over the pre described endurance lifetime, it causes the increase of deterioration of ESR characteristic and the internal generation heat by ripple current. Due to this, there is some possibility of vent open, bulging of sleeve and rubber, electrolyte leakage, and shot circuit, explosion and ignition in the worst case.

1.4 Using two or more capacitors in parallel

The circuit resistance can closely approximate the series resistance of the capacitor, causing an imbalance of ripple current loads within the capacitors. Careful wiring methods can minimize the possible application of an excessive ripple current to a capacitor.

Moreover, please do not use it in series.

1.5 Capacitor mounting considerations

(1) Double-sided circuit boards

Avoid wiring pattern runs, which pass between the mounted capacitor and the circuit board.

(2) Clearance for case mounted pressure relief ($\geq \phi 10$ mm)

Capacitors with case mounted pressure relief require sufficient clearance to allow for proper pressure relief operation.

The minimum clearance are dependent on capacitor diameters as follows.

- $\geq \phi 10$ mm : 2 mm minimum

(3) Wiring near the pressure relief ($\geq \phi 10$ mm)

Avoid locating high voltage or high current wiring or circuit board paths above the pressure relief.

Flammable, high temperature gas that exceeds 100 °C may be released which could dissolve the wire insulation and ignite.

(4) Circuit board patterns under the capacitor

Avoid circuit board runs under the capacitor, as an electrical short can occur due to an electrolyte leakage.

1.6 Electrical isolation of the capacitor

Completely isolate the capacitor as follows.

- Between the cathode and the case and between the anode terminal and other circuit paths.

1.7 Capacitor coating

The laminate coating is intended for marking and identification purposes and is not meant to electrically insulate the capacitor.

2. Capacitor handling techniques

2.1 Considerations before using

(1) Capacitors have a finite life. Do not reuse or recycle capacitors from used equipment.

(2) Transient recovery voltage may be generated in the capacitor due to dielectric absorption.

If required, this voltage can be discharged with a resistor with a value of about 1 k Ω .

(3) Capacitors stored for a long period of time may exhibit an increase in leakage current.

This can be corrected by gradually applying rated voltage in series with a resistor of approximately 1 k Ω .

(4) If capacitors are dropped, they can be damaged mechanically or electrically. Avoid using dropped capacitors.

(5) Dented or crushed capacitors should not be used.

The seal integrity can be damaged and loss of electrolyte/ shortened life can result.

2.2 Capacitor insertion

(1) Verify the correct capacitance and rated voltage of the capacitor.

(2) Verify the correct polarity of the capacitor before insertion.

(3) Verify the correct terminal dimension and land pattern size before mount to avoid stress on the terminals.

(4) Excessive mounting pressure can cause high leakage current, short circuit, or disconnection.

2.3 Reflow soldering

(1) Surface-mount type capacitor are exclusively for reflow soldering.

When reflow solder is used an ambient heat condition system such as the simultaneous use of infrared and hot-air is recommended.

(2) Observe proper soldering conditions (temperature, time, etc.). Do not exceed the specified limits.

If the peak temperature is high or if the heating time is long, it may cause deterioration of the electrical characteristics and life characteristics.

Recommended soldering condition is a guideline for ensuring the basic characteristics of the components, but not for the stable soldering conditions. Conditions for proper soldering should be set up according to individual conditions.

* The Temperature on capacitor top shall be measured by using thermal couple that is fixed firmly by epoxy glue.

(3) In case of use in 2 times reflow, 2nd reflow must be done when the capacitor's temperature return back to normal level.

(4) In our recommended reflow condition, the case discoloration and the case swelling might be slightly generated. But please acknowledge that these two phenomena do not influence the reliability of the product.

(5) The crack on top marking might be occurred by reflow heat stress.

But please acknowledge that it does not influence the reliability of the product.

(6) VPS (Vapor Phase Soldering) reflow can cause significant characteristics change and/ or mounting failure due to deformation by acute temperature rise.

VPS is acceptable provided that the process does not exceed recommended reflow profile and temperature rise is less than 3 degC/sec. Please contact Panasonic for detailed conditions.

2.4 Manual soldering

- (1) Observe temperature and time soldering specifications or do not exceed temperature of 350 °C for 3 seconds or less.
- (2) If a soldered capacitor must be removed and reinserted, avoid excessive stress on the capacitor leads.
- (3) Avoid physical contacts between the tip of the soldering iron and capacitors to prevent or capacitor failure.

2.5 Capacitor handling after soldering

- (1) Avoid moving the capacitor after soldering to prevent excessive stress on the lead wires where they enter the seal. The capacitor may break from element portion due to a torque at outer rim, causing a large stress to terminals.
- (2) Do not use the capacitor as a handle when moving the circuit board assembly. The total weight of the board would apply to element portion through terminals, and the capacitor may break.
- (3) Avoid striking the capacitor after assembly to prevent failure due to excessive shock. The capacitor may break due to excessive shock or load above specified range.

2.6 Circuit board cleaning

- (1) Circuit boards can be immersed or ultrasonically cleaned using suitable cleaning solvents for up to 5 minutes and up to 60 °C maximum temperatures. The boards should be thoroughly rinsed and dried. The use of ozone depleting cleaning agents is not recommended for the purpose of protecting our environment.

【Target solvent】

Pine Alpha ST-100S, Aqua Cleaner 210SEP, Clean-thru 750H / 750L / 710M, Sunelec B-12, Sunelec B-12, Cold Cleaner P3-375, Techno Cleaner 219, DK Be-clear CW-5790, Telpene Cleaner EC-7R, Technocare FRW-17 / FRW-1 / FRV-1

- (2) Avoid using the following solvent groups unless specifically allowed in the specification ;
 - (a) Halogenated cleaning solvents : except for solvent resistant capacitor types, halogenated solvents can permeate the seal and cause internal capacitor corrosion and failure.
For solvent resistant capacitors, carefully follow the temperature and time requirements based on the specification. 1,1,1-trichloroethane should never be used on any aluminum electrolytic capacitor.
 - (b) Alkaline solvents : could react and dissolve the aluminum case.
 - (c) Petroleum based solvents : deterioration of the rubber seal could result.
 - (d) Xylene : deterioration of the rubber seal could result.
 - (e) Acetone : removal of the ink markings on the vinyl sleeve could result.
- (3) A thorough drying after cleaning is required to remove residual cleaning solvents that may be trapped between the capacitor and the circuit board. Avoid drying temperatures, which exceed the upper category temperature of the capacitor.
- (4) Monitor the contamination levels of the cleaning solvents during use in terms of electrical conductivity, pH, specific gravity, or water content.
Chlorine levels can rise with contamination and adversely affect the performance of the capacitor.
Control the flux density in the cleaning agent to be less than 2 mass%.
- (5) Depending on the cleaning method, the marking on a capacitor may be erased or blurred.
※ Please consult us if you are not certain about acceptable cleaning solvents or cleaning methods.

2.7 Mounting adhesives and coating agents

When using mounting adhesives or coating agents to control humidity, avoid using materials containing halogenated solvents.

Also, avoid the use of chloroprene based polymers.

Harden on dry adhesive or coating agents well lest the solvent should be left.

After applying adhesives or coatings, dry thoroughly to prevent residual solvents from being trapped between the capacitor and the circuit board.

2.8 Fumigation

In exporting electronic appliances with aluminum electrolytic capacitors, in some cases fumigation treatment using such halogen compound as methyl bromide is conducted for wooden boxes.

If such boxes are not dried well, the halogen left in the box is dispersed while transported and enters in the capacitors inside.

This possibly causes electrical corrosion of the capacitors. Therefore, after performing fumigation and drying make sure that no halogen is left.

Don't perform fumigation treatment to the whole electronic appliances packed in a box.

Leave more than 1/3 of the sealing portion open, and do not cover that portion with any adhesives or coating.

2.9 Flux

If you use a halogen type (Chlorine type, Bromine type, etc.) high-activity flux, please use it after confirmation in advance, as it may have an impact on performance and reliability of this product due to the residue of the flux.

3. Precautions for using capacitors

3.1 Environmental conditions

Capacitors should not be stored or used in the following environments.

- (1) Exposure to temperatures above the upper category or below the lower category temperature of the capacitor.
- (2) Direct contact with water, salt water, or oil.
- (3) High humidity conditions where water could condense on the capacitor.
- (4) Exposure to toxic gases such as hydrogen sulfide, sulfuric acid, nitric acid, chlorine, chlorine compound, bromine, bromine compound or ammonia.
- (5) Exposure to ozone, radiation, or ultraviolet rays.
- (6) Vibration and shock conditions exceeding specified requirements.

Even within the specified requirements, a large vibration acceleration may be applied due to resonance, so be sure to evaluate and confirm with the actual product.

3.2 Electrical precautions

- (1) Avoid touching the terminals of a capacitor as a possible electric shock could result. The exposed aluminum case is not insulated and could also cause electric shock if touched.
- (2) Avoid short circuiting the area between the capacitor terminals with conductive materials including liquids such as acids or alkaline solutions.
- (3) A low-molecular-weight-shiroxane which is included in a silicon material shall causes abnormal electrical characteristics.

4. Emergency procedures

- (1) If the pressure relief of the capacitor operates, immediately turn off the equipment and disconnect from the power source.
This will minimize an additional damage caused by the vaporizing electrolyte.
- (2) Avoid contact with the escaping electrolyte gas, which can exceed 100 °C temperatures.
If electrolyte or gas enters the eye, immediately flush the eye with large amounts of water.
If electrolyte or gas is ingested by mouth, gargle with water.
If electrolyte contacts the skin, wash with soap and water.

5. Long term storage

- (1) Leakage current of a capacitor increases with long storage times. The aluminum oxide film deteriorates as a function of temperature and time.
If used without reconditioning, an abnormally high current will be required to restore the oxide film.
This surge current could cause the circuit or the capacitor to fail.
Expiration date is 42 months from outgoing inspection date.
For storage condition, keep room temperature (5 °C to 35 °C) and humidity (45 % to 85 %) where direct sunshine doesn't reach.
- (2) Environmental conditions
Do not store under condition outside the area described in the specification, and also under conditions listed below.
 - (a) Exposure to temperatures above the upper category or below the lower category temperature of the capacitor.
 - (b) Direct contact with water, salt water, or oil.
 - (c) High humidity conditions where water could condense on the capacitor.
 - (d) Exposure to toxic gases such as hydrogen sulfide, sulfuric acid, nitric acid, chlorine, Chlorine compound, Bromine, Bromine compound or ammonia.
 - (e) Exposure to ozone, radiation, or ultraviolet rays.
 - (f) Vibration and shock conditions exceeding specified requirements.

6. Capacitor disposal

When disposing capacitors, use one of the following methods.

- (1) Incinerate after crushing the capacitor or puncturing the can wall (to prevent explosion due to internal pressure rise).
- (2) Dispose as solid waste.

NOTE : Local laws may have specific disposal requirements which must be followed.

The precautions in using aluminum electrolytic capacitors follow the "Safety application guide for the use in fixed aluminum electrolytic capacitors for electronic equipment", RCR-2367D issued by JEITA in October 2017.
Please refer to the above application guide for details.

■ AEC-Q200 compliant

The products are tested based on all or part of the test conditions and methods defined in AEC-Q200. Please consult with Panasonic for the details of the product specification and specific evaluation test results, etc., and please review and approve Panasonic's product specification before ordering.

* Intellectual property right

We, Panasonic Group are providing the product and service that customers can use without anxiety, and are working positively on the protection of our products under intellectual property rights.

Representative patents relating to Conductive Polymer Hybrid Aluminum Electrolytic Capacitors are as follows:

US Patent	No.7497879, No.7621970, No.9208954
JP Patent	No.5360250
EP Patent	No.1808875

Line up

Surface mount type

Series	Part No.	Features	Small size	Large cap.	High ripple	High temp.	Long life	Category temperature range (°C)	Rated voltage range (V)	ESR (mΩ)	Capacitance range (μF)	Size code	Size (mm)									
													φD	L								
UPGRADE ZA	EEHZA---	Low ESR High ripple current Long life 105 °C 10000 h	●					-55 to 105	25 to 50	80 to 120	10 to 33	C	5.0	5.8								
									25 to 63	50 to 120	10 to 56	D	6.3	5.8								
										30 to 80	22 to 100	D8	6.3	7.7								
									25 to 80	27 to 45	22 to 220	F	8.0	10.2								
UPGRADE ZC	EEHZC---	Low ESR High ripple current Long life 125 °C 4000 h	●				-55 to 125	25 to 50	80 to 120	10 to 33	C	5.0	5.8									
								25 to 63	50 to 120	10 to 56	D	6.3	5.8									
									30 to 80	22 to 100	D8	6.3	7.7									
								25 to 80	27 to 45	22 to 220	F	8.0	10.2									
UPGRADE ZK	EEHZK---	Large capacitance High ripple current Long life 125 °C 4000 h	●	●	●	●	-55 to 125	25 to 35	80 to 100	33 to 47	C	5.0	5.8									
									50 to 60	56 to 82	D	6.3	5.8									
									30 to 35	100 to 150	D8	6.3	7.7									
									27	180 to 270	F	8.0	10.2									
NEW ZKU	EEHZK--U-	Large capacitance Long life 125 °C 4000 h	●	●	●	●	-55 to 125	25 to 35	20	330 to 470	G	10.0	10.2									
									80 to 100	39 to 56	C	5.0	5.8									
									50 to 60	68 to 100	D	6.3	5.8									
									30 to 35	120 to 180	D8	6.3	7.7									
UPGRADE ZE	EEHZE---	145 °C 2000 h 135 °C 4000 h				●	●	-55 to 145	25 to 63	27 to 40	33 to 220	F	8.0	10.2								
										20 to 30	56 to 330	G	10.0	10.2								
										ZS	EEHZS---	125 °C 4000 h	●	●	●	-55 to 125	25 to 63	11 to 15	150 to 560	G16	10.0	16.5

Radial lead type

Series	Part No.	Features	Small size	Large cap.	High ripple	High temp.	Long life	Category temperature range (°C)	Rated voltage range (V)	ESR (mΩ)	Capacitance range (μF)	Size code	Size (mm)		
													φD	L	
ZF	EEHAZF---	150 °C 1000 h					●	●	-55 to 150	25 to 63	27 to 40	33 to 150	F	8.0	9.5
											20 to 30	56 to 270	G	10.0	9.5

Diagram

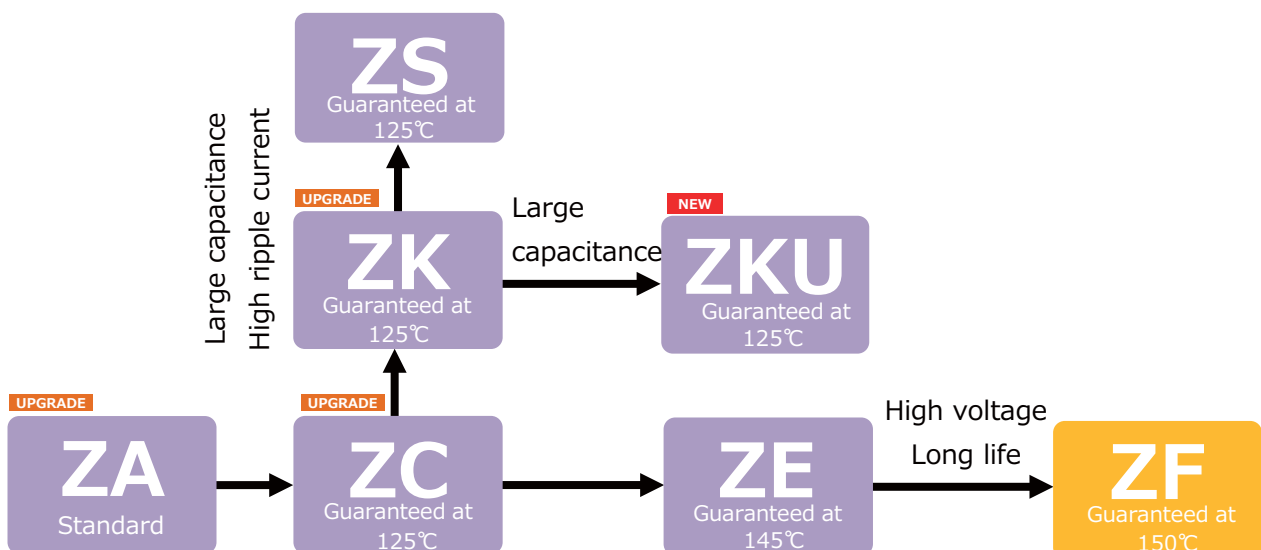

Size · ESR Matrix list

V	Series	10	22	27	33	39	47	56	68	82	100	120	150	180	220	270	330	390	470	560	
25	ZA		C(80)		C(80)		D(50)	D(50)	D8(30)		D8(30)		F(27)		F(27)		G(20)				
	ZC		C(80)		C(80)		D(50)	D(50)	D8(30)		D8(30)		F(27)		F(27)		G(20)				
	ZK						C(80)		D(50)	D(50)			D8(30)			F(27)				G(20)	
	ZKU							C(80)			D(50)			D8(30)							G(20)
	ZE															F(27)		G(20)			
	ZF													F(27)			G(20)				
	ZS																				G16(11)
35	ZA	C(100)	C(100)	D(60)	D(60)		D(60)		D8(35)		F(27)		F(27)		G(20)	G(20)					
	ZC	C(100)	C(100)		D(60)		D(60)		D8(35)		F(27)		F(27)		G(20)	G(20)					
	ZK				C(100)			D(60)			D8(35)			F(27)			G(20)				
	ZKU					C(100)			D(60)			D8(35)			F(27)			G(20)			
	ZE													F(27)			G(20)				
	ZF										F(30)			G(23)							
	ZS																				G16(11)
50	ZA	C(120)	D(80)		D8(40)		F(30)		F(30)		G(28)										
	ZC	C(120)	D(80)		D8(40)		F(30)		F(30)		G(28)	G(28)									
	ZE								F(30)		G(28)										
	ZF							F(35)			G(28)										
	ZS															G16(13)					
63	ZA	D(120)	D8(80)		F(40)		F(40)	G(30)	G(30)	G(30)											
	ZC	D(120)	D8(80)		F(40)		F(40)	G(30)	G(30)	G(30)											
	ZE				F(40)			G(30)		G(30)											
	ZF				F(40)			G(30)													
	ZS												G16(15)								
80	ZA		F(45)		G(36)																
	ZC		F(45)		G(36)		G(36)														

Size code (ESR mΩ)

New

Size code	Unit : mm		
C	φ5 x L5.8	F	φ8 x L10.2
D	φ6.3 x L5.8	G	φ10 x L10.2
D8	φ6.3 x L7.7	G16	φ10 x L16.5

F	φ8 x L9.5
G	φ10 x L9.5

V type A type

Explanation of part numbers

◇ **Part number system**

• Surface mount type

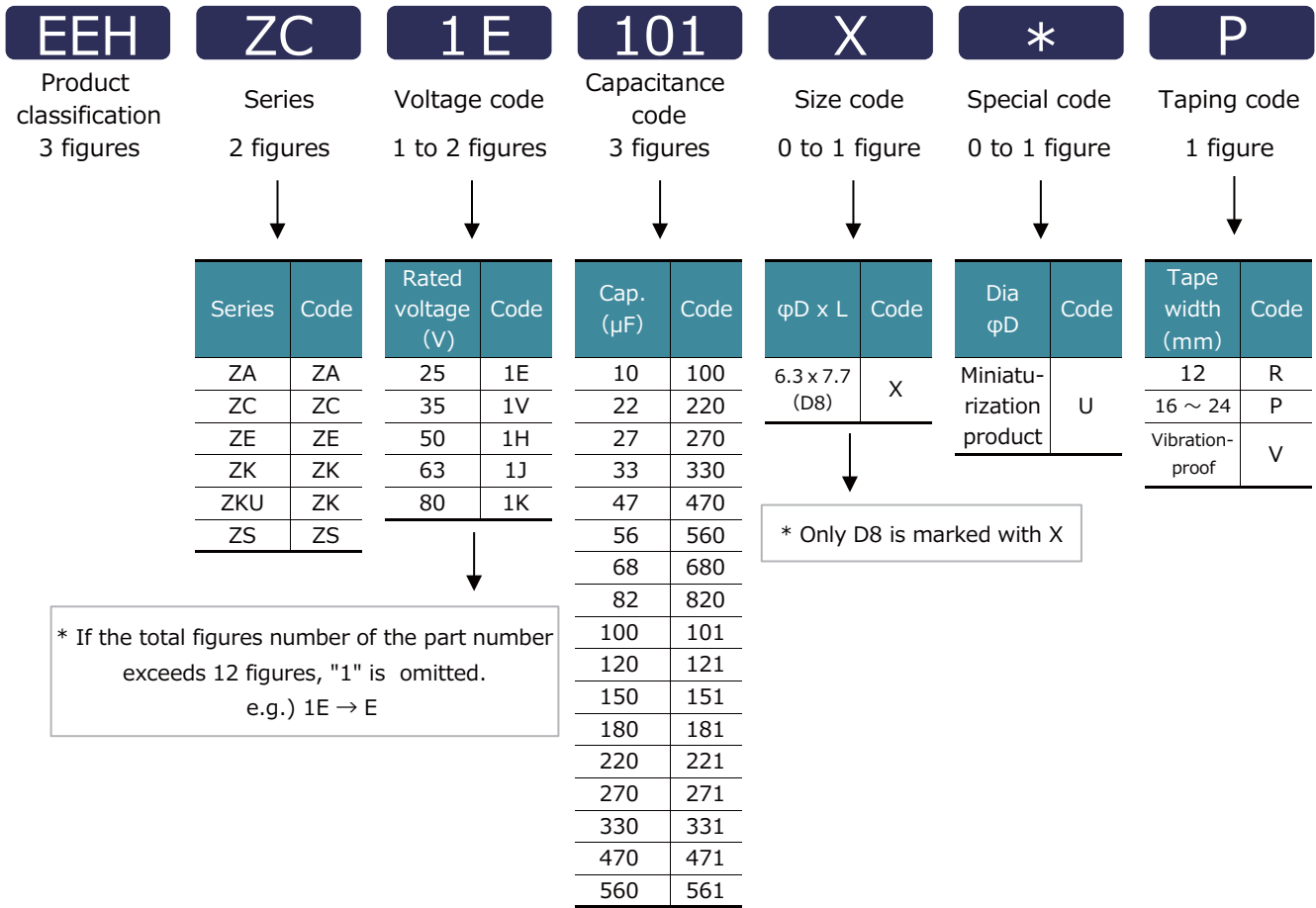

• Radial lead type

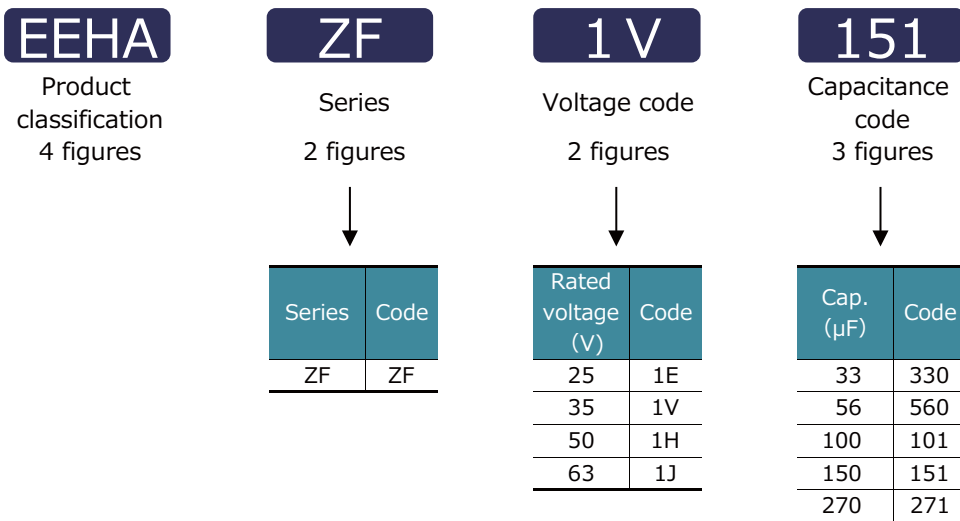

Mounting specification

Specifications for surface mount type

- Reflow guaranteed condition
- < RoHS compliant >

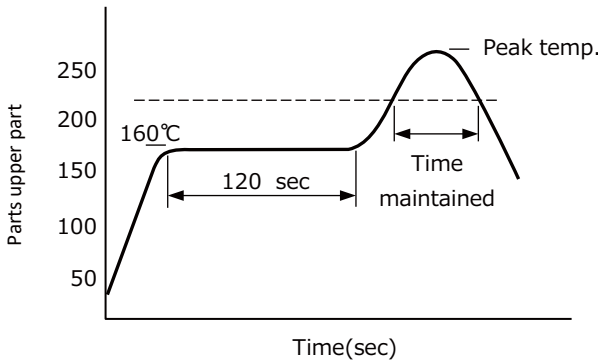

Size code	C, D, D8	F, G, G16	
Peak temp.	260°C (255°C)	245°C	260°C
Time in peak temperature	≥ 250°C 5 s (10 s)	≥ 240°C 10 s	≥ 250°C 5 s
Time maintained	≥ 230°C 30 s	≥ 230°C 30 s	≥ 230°C 30 s
	≥ 217°C 40 s	≥ 217°C 40 s	≥ 217°C 40 s
	≥ 200°C 70 s	≥ 200°C 70 s	≥ 200°C 70 s
Time of reflow	2 times	2 times	1 time

* For reflow, use a thermal condition system such as infrared and radiation (IR) or hot blas
 * Panasonic have several series available for pure Tin terminal ZVEI reflow based on J-STD-020D (JEDEC).
 (Please contact sales for details.)

Specifications for radial lead type

- Flow soldering condition
- < RoHS compliant >

	Temperature	Time	Flow number
Soldering condition	260°C + 5°C or less	10 sec +1 sec or less	1 time

Vibration-proof products

The size and shape are different from standard products.
 Please inquire details of our company.

< Size code : D, D8 >

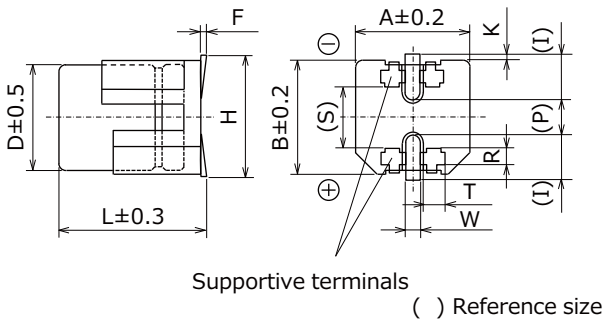

Unit : mm

Size code	φD	L	A, B	H max.	F	I	W
D	6.3	6.1	6.6	7.8	0 to +0.15	2.4	0.65±0.1
D8	6.3	8.0	6.6	7.8	0 to +0.15	2.4	0.65±0.1

Size code	P	K	R	S	T
D	2.2	0.35 ^{+0.15/-0.20}	1.1±0.2	3.3	1.05±0.2
D8	2.2	0.35 ^{+0.15/-0.20}	1.1±0.2	3.3	1.05±0.2

< Size code : F, G, G16 >

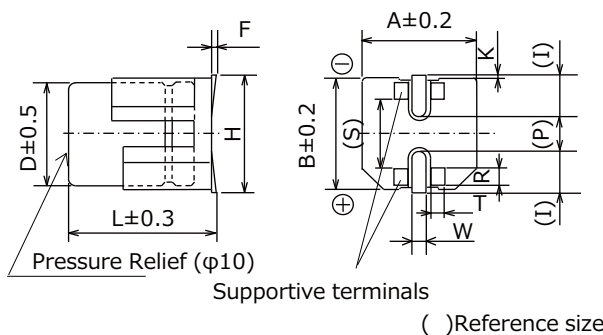

Unit : mm

Size code	φD	L	A, B	H max.	F	I	W
F	8.0	10.5	8.3	10.0	0 to +0.15	3.4	1.2±0.2
G	10.0	10.5	10.3	12.0	0 to +0.15	3.5	1.2±0.2
G16	10.0	16.8	10.3	11.0 ^{*1}	0 to +0.15	3.2	1.2±0.2

*1:±0.2

Size code	P	K	R	S	T
F	3.1	0.70±0.2	0.70±0.2	5.3	1.3±0.2
G	4.6	0.70±0.2	0.70±0.2	6.9	1.3±0.2
G16	4.6	---	0.70±0.2	6.9	1.3±0.2

Mounting specification

Land / Pad pattern

The circuit board land/pad pattern size for chip capacitors is specified in the following table. The land pitch influences installation strength and consider it.

< Standard products >

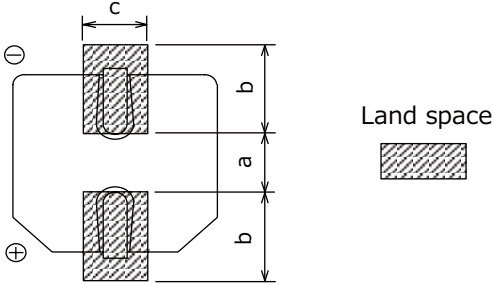

Unit : mm

Size code	a	b	c
C : $\phi 5 \times L5.8$	1.5	2.8	1.6
D : $\phi 6.3 \times L5.8$	1.8	3.2	1.6
D8 : $\phi 6.3 \times L7.7$	1.8	3.2	1.6
F : $\phi 8 \times L10.2$	3.1	4.0	2.0
G : $\phi 10 \times L10.2$	4.6	4.1	2.0
G16 : $\phi 10 \times L16.5$	4.6	4.1	2.0

When size "a" is wide, back fillet can be made, decreasing fitting strength.

*Take mounting conditions, solderability and fitting strength into consideration when selecting parts for your company's design.

< Vibration-proof products >

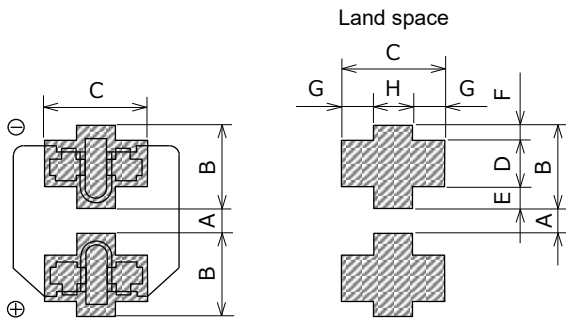

Unit : mm

Size code	A	B	C	D
D : $\phi 6.3 \times L5.8$	1.2	3.6	3.2	2.0
D8 : $\phi 6.3 \times L7.7$	1.2	3.6	3.2	2.0

Size code	E	F	G	H
D : $\phi 6.3 \times L5.8$	0.95	0.65	1.0	1.2
D8 : $\phi 6.3 \times L7.7$	0.95	0.65	1.0	1.2

When size "A" is wide, back fillet can be made, decreasing fitting strength.

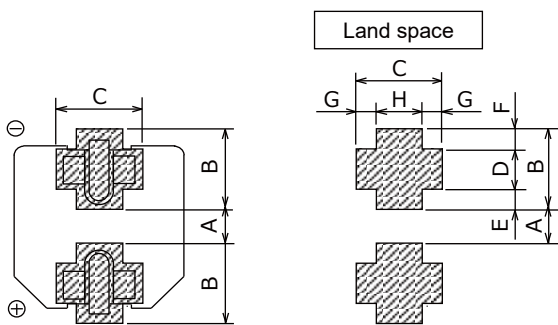

Unit : mm

Size code	A	B	C	D
F : $\phi 8 \times L10.2$	2.7	4.0	4.7	1.3
G : $\phi 10 \times L10.2$	3.9	4.4	4.7	1.3
G16 : $\phi 10 \times L16.5$	3.9	4.4	4.7	1.3

Size code	E	F	G	H
F : $\phi 8 \times L10.2$	1.0	1.7	1.1	2.5
G : $\phi 10 \times L10.2$	1.2	1.9	1.1	2.5
G16 : $\phi 10 \times L16.5$	1.2	1.9	1.1	2.5

When size "A" is wide, back fillet can be made, decreasing fitting strength.

*Take mounting conditions, solderability and fitting strength into consideration when selecting parts for your company's design.

Packaging specifications

Specifications for surface mount type

- Reel dimensions (not to scale)

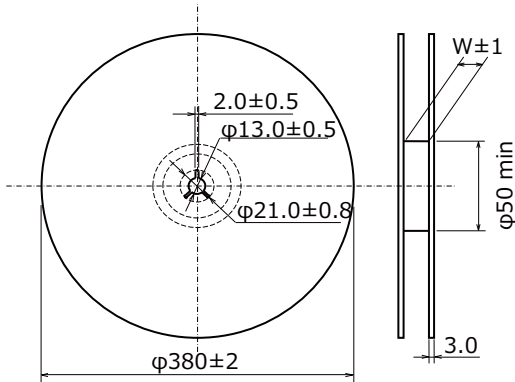

Unit : mm

Size code	W
C	14.0
D, D8	18.0
F, G, G16	26.0

- Dimensions of outer carton box

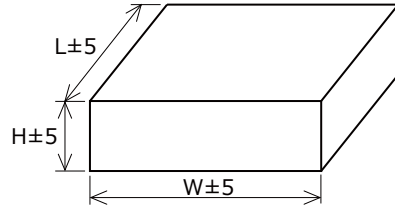

Unit : mm

Size code	H	W, L
C	220	395
D, D8	250	395
F, G, G16	220	395

- Min.packing quantity

Size code	Min.packing (pcs.)
C, D	1000
D8	900
F, G	500
G16	250

- Taping dimensions

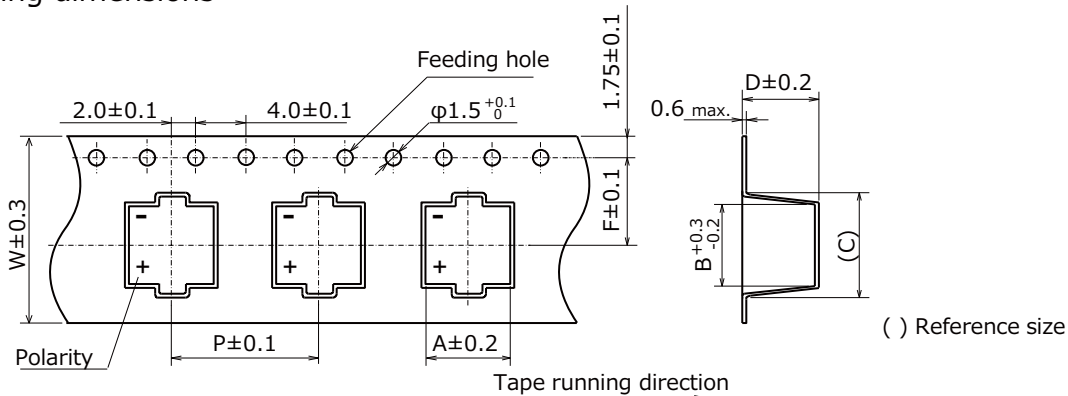

* Ask factory for technical specifications

Unit : mm

Size code	A	B	C	D	P	F	W
C	5.7	5.7	8.0	6.4	12.0	5.5	12.0
D	7.0	7.0	9.0	6.4	12.0	7.5	16.0
D8	7.0	7.0	9.0	8.4	12.0	7.5	16.0
F	8.7	8.7	12.5	11.0	16.0	11.5	24.0
G	10.7	10.7	14.5	11.0	16.0	11.5	24.0
G16	10.7	10.7	14.5	17.5	20.0	11.5	24.0

Specifications for radial lead type

- Packing quantity

Size code	Quantity (pcs. / Bag)	Quantity (pcs. / Box)
F (φ8×L9.5)	200	4000
G (φ10×L9.5)	200	2000

UPGRADE

Surface Mount Type

ZA series **V** type

High temperature lead-free reflow



Hybrid

Features

- Endurance : 10000 h at 105 °C
- Low ESR and high ripple current (70 % over, Lower ESR than current V-FP)
- High voltage (to 80 V)
- Equivalent to conductive polymer type aluminum electrolytic capacitor (There are little characteristics change by temperature and frequency)
- Vibration-proof product is available upon request. New lineup of φ6.3 product. (φ6.3, φ8, φ10)
- AEC-Q200 compliant
- RoHS compliant

Specifications

Size code	C	D	D8	F	G
Category temp. range	-55 °C to +105 °C				
Rated voltage range	25 V to 50 V	25 V to 63 V		25 V to 80 V	
Nominal cap.range	10 μF to 33 μF	10 μF to 56 μF	22 μF to 100 μF	22 μF to 220 μF	33 μF to 330 μF
Capacitance tolerance	±20 % (120 Hz / +20 °C)				
DC leakage current	I ≤ 0.01 CV or 3 (μA) After 2 minutes (whichever is greater)				
Dissipation factor (tan δ)	Please see the attached characteristics list				
Endurance	+105 °C ± 2 °C, 10000 h, apply the rated ripple current without exceeding the rated voltage.				
	Capacitance change	Within ±30% of the initial value			
	Dissipation factor (tan δ)	≤ 200 % of the initial limit			
	ESR	≤ 200 % of the initial limit			
	DC leakage current	Within the initial limit			
ESR after endurance (Ω / 100 kHz)(-40 °C)	Size code				
	C	D	D8	F	G
	2.0	1.4	0.8	0.4	0.3
Shelf life	After storage for 1000 hours at +105 °C ± 2 °C with no voltage applied and then being stabilized at +20 °C, capacitors shall meet the limits specified in endurance. (With voltage treatment)				
Damp heat (Load)	+85 °C ± 2 °C, 85 % to 90 %, 2000 h, rated voltage applied				
	Capacitance change	Within ±30% of the initial value			
	Dissipation factor (tan δ)	≤ 200 % of the initial limit			
	ESR	≤ 200 % of the initial limit			
DC leakage current	Within the initial limit				
Resistance to soldering heat	After reflow soldering and then being stabilized at +20 °C, capacitors shall meet the following limits.				
	Capacitance change	Within ±10% of the initial value			
	Dissipation factor (tan δ)	Within the initial limit			
DC leakage current	Within the initial limit				

Marking

Example : 25 V 33 μF
Marking color : BLACK

Capacitance (μF)
Series identification
Rated voltage code
Lot number

R. voltage code	Unit : V
E	25
V	35
H	50
J	63
K	80

Dimensions (not to scale)

[Standard]

Size code	φD	L	A, B	H max.	I	W	P	K
C	5.0	5.8±0.3	5.3	6.5	2.2	0.65±0.1	1.5	0.35 ^{+0.15} / _{-0.20}
D	6.3	5.8±0.3	6.6	7.8	2.6	0.65±0.1	1.8	0.35 ^{+0.15} / _{-0.20}
D8	6.3	7.7±0.3	6.6	7.8	2.6	0.65±0.1	1.8	0.35 ^{+0.15} / _{-0.20}
F	8.0	10.2±0.3	8.3	10	3.4	0.90±0.2	3.1	0.70±0.2
G	10.0	10.2±0.3	10.3	12.0	3.5	0.90±0.2	4.6	0.70±0.2

[Vibration-proof product]
< Size code : D, D8 >

< Size code : F, G >

Size code	φD	L	A, B	H max.	F	I	W	P	K	R	S	T
D	6.3	6.1±0.3	6.6	7.8	0 to +0.15	2.4	0.65±0.1	2.2	0.35 ^{+0.15} / _{-0.20}	1.1±0.2	3.3	1.05±0.2
D8	6.3	8.0±0.3	6.6	7.8	0 to +0.15	2.4	0.65±0.1	2.2	0.35 ^{+0.15} / _{-0.20}	1.1±0.2	3.3	1.05±0.2
F	8.0	10.5±0.3	8.3	10.0	0 to +0.15	3.4	1.2±0.2	3.1	0.70±0.2	0.70±0.2	5.3	1.3±0.2
G	10.0	10.5±0.3	10.3	12.0	0 to +0.15	3.5	1.2±0.2	4.6	0.70±0.2	0.70±0.2	6.9	1.3±0.2

Characteristics list

Endurance : 105 °C 10000 h

Rated voltage (V)	Capacitance (±20 %) (μF)	Case size (mm)			Size code	Specification			Part number		Min. packaging q'ty
		φD	L			Ripple current*1 (mA rms)	ESR*2 (mΩ)	tan δ*3	Standard Product	Vibration-proof product	Taping (pcs)
			Standard	Vibration-proof							
25	NEW 22	5.0	5.8	-	C	900	80	0.14	EEHZA1E220R	-	1000
	33	5.0	5.8	-	C	900	80	0.14	EEHZA1E330R	-	1000
	NEW 47	6.3	5.8	6.1	D	1300	50	0.14	EEHZA1E470P	EEHZA1E470V	1000
	56	6.3	5.8	6.1	D	1300	50	0.14	EEHZA1E560P	EEHZA1E560V	1000
	NEW 68	6.3	7.7	8.0	D8	2000	30	0.14	EEHZA1E680XP	EEHZA1E680XV	900
	100	6.3	7.7	8.0	D8	2000	30	0.14	EEHZA1E101XP	EEHZA1E101XV	900
	NEW 150	8.0	10.2	10.5	F	2300	27	0.14	EEHZA1E151P	EEHZA1E151V	500
	220	8.0	10.2	10.5	F	2300	27	0.14	EEHZA1E221P	EEHZA1E221V	500
35	330	10.0	10.2	10.5	G	2500	20	0.14	EEHZA1E331P	EEHZA1E331V	500
	NEW 10	5.0	5.8	-	C	900	100	0.12	EEHZA1V100R	-	1000
	22	5.0	5.8	-	C	900	100	0.12	EEHZA1V220R	-	1000
	27	6.3	5.8	6.1	D	1300	60	0.12	EEHZA1V270P	EEHZA1V270V	1000
	NEW 33	6.3	5.8	6.1	D	1300	60	0.12	EEHZA1V330P	EEHZA1V330V	1000
	47	6.3	5.8	6.1	D	1300	60	0.12	EEHZA1V470P	EEHZA1V470V	1000
	68	6.3	7.7	8.0	D8	2000	35	0.12	EEHZA1V680XP	EEHZA1V680XV	900
	NEW 100	8.0	10.2	10.5	F	2300	27	0.12	EEHZA1V101P	EEHZA1V101V	500
50	150	8.0	10.2	10.5	F	2300	27	0.12	EEHZA1V151P	EEHZA1V151V	500
	NEW 220	10.0	10.2	10.5	G	2500	20	0.12	EEHZA1V221P	EEHZA1V221V	500
	270	10.0	10.2	10.5	G	2500	20	0.12	EEHZA1V271P	EEHZA1V271V	500
	10	5.0	5.8	-	C	750	120	0.10	EEHZA1H100R	-	1000
	22	6.3	5.8	6.1	D	1100	80	0.10	EEHZA1H220P	EEHZA1H220V	1000
	33	6.3	7.7	8.0	D8	1600	40	0.10	EEHZA1H330XP	EEHZA1H330XV	900
	NEW 47	8.0	10.2	10.5	F	1800	30	0.10	EEHZA1H470P	EEHZA1H470V	500
	68	8.0	10.2	10.5	F	1800	30	0.10	EEHZA1H680P	EEHZA1H680V	500
63	100	10.0	10.2	10.5	G	2000	28	0.10	EEHZA1H101P	EEHZA1H101V	500
	10	6.3	5.8	6.1	D	1000	120	0.08	EEHZA1J100P	EEHZA1J100V	1000
	22	6.3	7.7	8.0	D8	1500	80	0.08	EEHZA1J220XP	EEHZA1J220XV	900
	33	8.0	10.2	10.5	F	1700	40	0.08	EEHZA1J330P	EEHZA1J330V	500
	NEW 47	8.0	10.2	10.5	F	1700	40	0.08	EEHZA1J470P	EEHZA1J470V	500
	56	10.0	10.2	10.5	G	1800	30	0.08	EEHZA1J560P	EEHZA1J560V	500
	NEW 68	10.0	10.2	10.5	G	1800	30	0.08	EEHZA1J680P	EEHZA1J680V	500
	NEW 82	10.0	10.2	10.5	G	1800	30	0.08	EEHZA1J820P	EEHZA1J820V	500
80	22	8.0	10.2	10.5	F	1550	45	0.08	EEHZA1K220P	EEHZA1K220V	500
	33	10.0	10.2	10.5	G	1700	36	0.08	EEHZA1K330P	EEHZA1K330V	500

*1: Ripple current (100 kHz / +105 °C) *2: ESR (100 kHz / +20 °C) *3: tan δ (120 Hz / +20 °C)

◆ Please refer to the page of "Reflow profile" and "The taping dimensions".

◆ The dimensions of the vibration-proof products, please refer to the page of the mounting specification.

Frequency correction factor for ripple current

Rated capacitance (C)	Frequency (f)	100 Hz ≤ f < 200 Hz	200 Hz ≤ f < 300 Hz	300 Hz ≤ f < 500 Hz	500 Hz ≤ f < 1 kHz
C < 47 μF	Correction factor	0.10	0.10	0.15	0.20
47 μF ≤ C < 150 μF		0.15	0.20	0.25	0.30
150 μF ≤ C		0.15	0.25	0.25	0.30
Rated capacitance (C)	Frequency (f)	1 kHz ≤ f < 2 kHz	2 kHz ≤ f < 3 kHz	3 kHz ≤ f < 5 kHz	5 kHz ≤ f < 10 kHz
C < 47 μF	Correction factor	0.30	0.40	0.45	0.50
47 μF ≤ C < 150 μF		0.40	0.45	0.55	0.60
150 μF ≤ C		0.45	0.50	0.60	0.65
Rated capacitance (C)	Frequency (f)	10 kHz ≤ f < 15 kHz	15 kHz ≤ f < 20 kHz	20 kHz ≤ f < 30 kHz	30 kHz ≤ f < 40 kHz
C < 47 μF	Correction factor	0.60	0.65	0.70	0.75
47 μF ≤ C < 150 μF		0.70	0.75	0.80	0.80
150 μF ≤ C		0.75	0.80	0.85	0.85
Rated capacitance (C)	Frequency (f)	40 kHz ≤ f < 50 kHz	50 kHz ≤ f < 100 kHz	100 kHz ≤ f < 500 kHz	500 kHz ≤ f
C < 47 μF	Correction factor	0.80	0.85	1.00	1.05
47 μF ≤ C < 150 μF		0.85	0.90	1.00	1.00
150 μF ≤ C		0.85	0.90	1.00	1.00

UPGRADE

Surface Mount Type

ZC series **V** type

High temperature lead-free reflow



Hybrid

Features

- Endurance: 4000 h at 125 °C (High temperature / Long life)
- Low ESR and high ripple current (85 % over, Lower ESR than current V-TP)
- High-withstand voltage (to 80 V), Low LC (0.01 CV or 3 μA)
- Equivalent to conductive polymer type aluminum electrolytic capacitor (There are little characteristics change by temperature and frequency)
- Vibration-proof product is available upon request. New lineup of φ6.3 product. (φ6.3, φ8, φ10)
- AEC-Q200 compliant
- RoHS compliant

Specifications

Size code	C	D	D8	F	G
Category temp. range	-55 °C to +125 °C				
Rated voltage range	25 V to 50 V	25 V to 63 V		25 V to 80 V	
Nominal cap.range	10 μF to 33 μF	10 μF to 56 μF	22 μF to 100 μF	22 μF to 220 μF	33 μF to 330 μF
Capacitance tolerance	±20 % (120 Hz / +20 °C)				
DC leakage current	I ≤ 0.01 CV or 3 (μA) After 2 minutes (whichever is greater)				
Dissipation factor (tan δ)	Please see the attached characteristics list				
Endurance 1	+125 °C ± 2 °C, 4000 h, apply the rated ripple current without exceeding the rated voltage.				
	Capacitance change	Within ±30% of the initial value			
	Dissipation factor (tan δ)	≤ 200 % of the initial limit			
	ESR	≤ 200 % of the initial limit			
	DC leakage current	Within the initial limit			
Endurance 2	+125 °C ± 2 °C, 3000 h, apply the rated ripple current without exceeding the rated voltage.				
	Capacitance change	Within ±30% of the initial value			
	Dissipation factor (tan δ)	≤ 200 % of the initial limit			
	ESR	≤ 300 % of the initial limit			
	DC leakage current	Within the initial limit			
Shelf life	After storage for 1000 hours at +125 °C ± 2 °C with no voltage applied and then being stabilized at +20 °C, capacitors shall meet the limits specified in endurance. (With voltage treatment)				
Damp heat (Load)	+85 °C ± 2 °C, 85 % to 90 %, 2000 h, rated voltage applied				
	Capacitance change	Within ±30% of the initial value			
	Dissipation factor (tan δ)	≤ 200 % of the initial limit			
	ESR	≤ 200 % of the initial limit			
	DC leakage current	Within the initial limit			
Resistance to soldering heat	After reflow soldering and then being stabilized at +20 °C, capacitors shall meet the following limits.				
	Capacitance change	Within ±10% of the initial value			
	Dissipation factor (tan δ)	Within the initial limit			
	DC leakage current	Within the initial limit			

Marking

Example : 25 V 33 μF
Marking color : BLACK

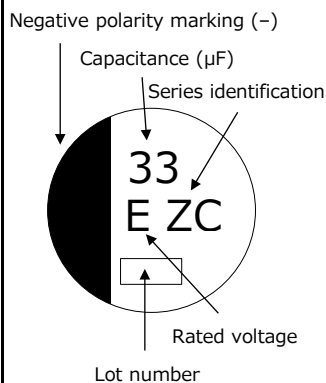

R. voltage code	Unit : V
E	25
V	35
H	50
J	63
K	80

Dimensions (not to scale)

[Standard]

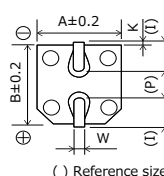
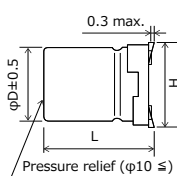

Unit : mm

Size code	φD	L	A, B	H _{max.}	I	W	P	K
C	5.0	5.8±0.3	5.3	6.5	2.2	0.65±0.1	1.5	0.35 ^{+0.15} _{-0.20}
D	6.3	5.8±0.3	6.6	7.8	2.6	0.65±0.1	1.8	0.35 ^{+0.15} _{-0.20}
D8	6.3	7.7±0.3	6.6	7.8	2.6	0.65±0.1	1.8	0.35 ^{+0.15} _{-0.20}
F	8.0	10.2±0.3	8.3	10	3.4	0.90±0.2	3.1	0.70±0.2
G	10.0	10.2±0.3	10.3	12.0	3.5	0.90±0.2	4.6	0.70±0.2

[Vibration-proof product]

< Size code : D, D8 >

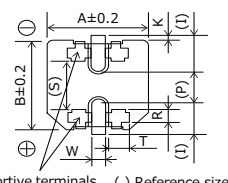
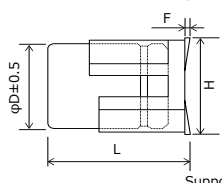

< Size code : F, G >

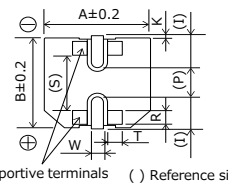
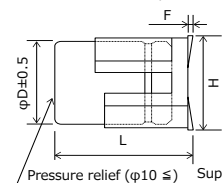

Unit : mm

Size code	φD	L	A, B	H _{max.}	F	I	W	P	K	R	S	T
D	6.3	6.1±0.3	6.6	7.8	0 to +0.15	2.4	0.65±0.1	2.2	0.35 ^{+0.15} _{-0.20}	1.1±0.2	3.3	1.05±0.2
D8	6.3	8.0±0.3	6.6	7.8	0 to +0.15	2.4	0.65±0.1	2.2	0.35 ^{+0.15} _{-0.20}	1.1±0.2	3.3	1.05±0.2
F	8.0	10.5±0.3	8.3	10.0	0 to +0.15	3.4	1.2±0.2	3.1	0.70±0.2	0.70±0.2	5.3	1.3±0.2
G	10.0	10.5±0.3	10.3	12.0	0 to +0.15	3.5	1.2±0.2	4.6	0.70±0.2	0.70±0.2	6.9	1.3±0.2

Characteristics list

Endurance 1 : 125 °C 4000 h

Endurance 2 : 125 °C 3000 h

Rated voltage (V)	Capacitance (±20 %) (μF)	Case size (mm)			Size code	Specification				Part number		Min. packaging q'ty
		φD	L			Ripple current *1 (mA rms)	ESR *2 (mΩ)	tan δ *3	Standard Product	Vibration-proof product	Taping (pcs)	
			Standard	Vibration-proof								Endurance 1
25	NEW 22	5.0	5.8	-	C	550	-	80	0.14	EEHZC1E220R	-	1000
	33	5.0	5.8	-	C	550	-	80	0.14	EEHZC1E330R	-	1000
	NEW 47	6.3	5.8	6.1	D	900	-	50	0.14	EEHZC1E470P	EEHZC1E470V	1000
	56	6.3	5.8	6.1	D	900	-	50	0.14	EEHZC1E560P	EEHZC1E560V	1000
	NEW 68	6.3	7.7	8.0	D8	1400	-	30	0.14	EEHZC1E680XP	EEHZC1E680XV	900
	100	6.3	7.7	8.0	D8	1400	-	30	0.14	EEHZC1E101XP	EEHZC1E101XV	900
	NEW 150	8.0	10.2	10.5	F	1600	1900	27	0.14	EEHZC1E151P	EEHZC1E151V	500
	220	8.0	10.2	10.5	F	1600	1900	27	0.14	EEHZC1E221P	EEHZC1E221V	500
	330	10.0	10.2	10.5	G	2000	2900	20	0.14	EEHZC1E331P	EEHZC1E331V	500
	35	NEW 10	5.0	5.8	-	C	550	-	100	0.12	EEHZC1V100R	-
22		5.0	5.8	-	C	550	-	100	0.12	EEHZC1V220R	-	1000
NEW 33		6.3	5.8	6.1	D	900	-	60	0.12	EEHZC1V330P	EEHZC1V330V	1000
47		6.3	5.8	6.1	D	900	-	60	0.12	EEHZC1V470P	EEHZC1V470V	1000
68		6.3	7.7	8.0	D8	1400	-	35	0.12	EEHZC1V680XP	EEHZC1V680XV	900
NEW 100		8.0	10.2	10.5	F	1600	1900	27	0.12	EEHZC1V101P	EEHZC1V101V	500
150		8.0	10.2	10.5	F	1600	1900	27	0.12	EEHZC1V151P	EEHZC1V151V	500
NEW 220		10.0	10.2	10.5	G	2000	2800	20	0.12	EEHZC1V221P	EEHZC1V221V	500
270		10.0	10.2	10.5	G	2000	2800	20	0.12	EEHZC1V271P	EEHZC1V271V	500
50		10	5.0	5.8	-	C	500	-	120	0.10	EEHZC1H100R	-
	22	6.3	5.8	6.1	D	750	-	80	0.10	EEHZC1H220P	EEHZC1H220V	1000
	33	6.3	7.7	8.0	D8	1100	-	40	0.10	EEHZC1H330XP	EEHZC1H330XV	900
	NEW 47	8.0	10.2	10.5	F	1250	-	30	0.10	EEHZC1H470P	EEHZC1H470V	500
	68	8.0	10.2	10.5	F	1250	-	30	0.10	EEHZC1H680P	EEHZC1H680V	500
	100	10.0	10.2	10.5	G	1600	-	28	0.10	EEHZC1H101P	EEHZC1H101V	500
	120	10.0	10.2	10.5	G	1600	-	28	0.10	EEHZC1H121P	EEHZC1H121V	500
63	10	6.3	5.8	6.1	D	700	-	120	0.08	EEHZC1J100P	EEHZC1J100V	1000
	22	6.3	7.7	8.0	D8	900	-	80	0.08	EEHZC1J220XP	EEHZC1J220XV	900
	33	8.0	10.2	10.5	F	1100	-	40	0.08	EEHZC1J330P	EEHZC1J330V	500
	47	8.0	10.2	10.5	F	1100	-	40	0.08	EEHZC1J470P	EEHZC1J470V	500
	56	10.0	10.2	10.5	G	1400	-	30	0.08	EEHZC1J560P	EEHZC1J560V	500
	68	10.0	10.2	10.5	G	1400	-	30	0.08	EEHZC1J680P	EEHZC1J680V	500
	82	10.0	10.2	10.5	G	1400	-	30	0.08	EEHZC1J820P	EEHZC1J820V	500
80	22	8.0	10.2	10.5	F	1050	-	45	0.08	EEHZC1K220P	EEHZC1K220V	500
	33	10.0	10.2	10.5	G	1360	-	36	0.08	EEHZC1K330P	EEHZC1K330V	500
	47	10.0	10.2	10.5	G	1360	-	36	0.08	EEHZC1K470P	EEHZC1K470V	500

*1: Ripple current (100 kHz / +125 °C) *2: ESR (100 kHz / +20 °C) *3: tan δ (120 Hz / +20 °C)

◆ Please refer to the page of "Reflow profile" and "The taping dimensions".

◆ The dimensions of the vibration-proof products, please refer to the page of the mounting specification.

Frequency correction factor for ripple current

Rated capacitance (C)	Frequency (f)	100 Hz ≤ f < 200 Hz	200 Hz ≤ f < 300 Hz	300 Hz ≤ f < 500 Hz	500 Hz ≤ f < 1 kHz
C < 47 μF	Correction factor	0.10	0.10	0.15	0.20
47 μF ≤ C < 150 μF		0.15	0.20	0.25	0.30
150 μF ≤ C		0.15	0.25	0.25	0.30
Rated capacitance (C)	Frequency (f)	1 kHz ≤ f < 2 kHz	2 kHz ≤ f < 3 kHz	3 kHz ≤ f < 5 kHz	5 kHz ≤ f < 10 kHz
C < 47 μF	Correction factor	0.30	0.40	0.45	0.50
47 μF ≤ C < 150 μF		0.40	0.45	0.55	0.60
150 μF ≤ C		0.45	0.50	0.60	0.65
Rated capacitance (C)	Frequency (f)	10 kHz ≤ f < 15 kHz	15 kHz ≤ f < 20 kHz	20 kHz ≤ f < 30 kHz	30 kHz ≤ f < 40 kHz
C < 47 μF	Correction factor	0.60	0.65	0.70	0.75
47 μF ≤ C < 150 μF		0.70	0.75	0.80	0.80
150 μF ≤ C		0.75	0.80	0.85	0.85
Rated capacitance (C)	Frequency (f)	40 kHz ≤ f < 50 kHz	50 kHz ≤ f < 100 kHz	100 kHz ≤ f < 500 kHz	500 kHz ≤ f
C < 47 μF	Correction factor	0.80	0.85	1.00	1.05
47 μF ≤ C < 150 μF		0.85	0.90	1.00	1.00
150 μF ≤ C		0.85	0.90	1.00	1.00

After endurance ESR (100 kHz, -40 °C)

Size	φ5 x L5.8	φ6.3 x L5.8	φ6.3 x L7.7	φ8 x L10.2	φ10 x L10.2
ESR (Ω)	2	1.4	0.8	0.4	0.3

UPGRADE

Surface Mount Type

ZK series **V** type

High temperature lead-free reflow



Hybrid

Features

- High capacitance and High ripple current compared with ZC series
- Endurance : 4000 h at 125 °C (High temperature / Long life)
- Low ESR (85 % over, Lower ESR than Current V-TP), Low LC (0.01 CV or 3 μA)
- Equivalent to conductive polymer type Aluminum Electrolytic Capacitor (There are little characteristics change by temperature and frequency)
- Vibration-proof product is available upon request. New lineup of φ6.3 product. (φ6.3, φ8, φ10)
- AEC-Q200 compliant
- RoHS compliant

Specifications

Size code	C	D	D8	F	G
Category temp. range	-55 °C to +125 °C				
Rated voltage range	25 V to 35 V				
Nominal cap.range	33 μF to 47 μF	56 μF to 82 μF	100 μF to 150 μF	180 μF to 270 μF	330 μF to 470 μF
Capacitance tolerance	±20 % (120 Hz / +20 °C)				
DC leakage current	I ≤ 0.01 CV or 3 (μA) After 2 minutes (whichever is greater)				
Dissipation factor (tan δ)	Please see the attached characteristics list				
Endurance	+125 °C ± 2 °C, 4000 h, apply the rated ripple current without exceeding the rated voltage.				
	Capacitance change	Within ±30% of the initial value			
	Dissipation factor (tan δ)	≤ 200 % of the initial limit			
	ESR	≤ 200 % of the initial limit			
	DC leakage current	Within the initial limit			
Shelf life	After storage for 1000 hours at +125 °C ± 2 °C with no voltage applied and then being stabilized at +20 °C, capacitors shall meet the limits specified in endurance. (With voltage treatment)				
	+85 °C ± 2 °C, 85 % to 90 %, 2000 h, rated voltage applied				
Damp heat (Load)	Capacitance change				
	Dissipation factor (tan δ)				
	ESR				
	DC leakage current				
Resistance to soldering heat	After reflow soldering and then being stabilized at +20 °C, capacitors shall meet the following limits.				
	Capacitance change				
	Dissipation factor (tan δ)				
	DC leakage current				

Marking

Example : 25 V 47 μF
Marking color : BLACK

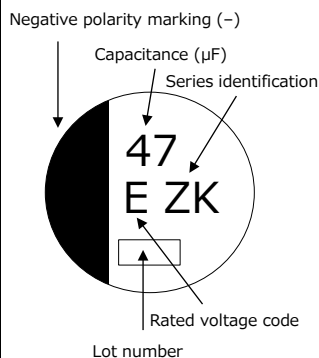

R. voltage code	Unit : V
E	25
V	35

Dimensions (not to scale)

[Standard]

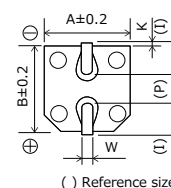
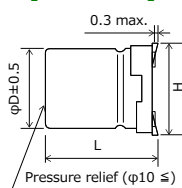

Size code	φD	L	A, B	H max.	I	W	P	K
C	5.0	5.8±0.3	5.3	6.5	2.2	0.65±0.1	1.5	0.35 ^{+0.15} _{-0.20}
D	6.3	5.8±0.3	6.6	7.8	2.6	0.65±0.1	1.8	0.35 ^{+0.15} _{-0.20}
D8	6.3	7.7±0.3	6.6	7.8	2.6	0.65±0.1	1.8	0.35 ^{+0.15} _{-0.20}
F	8.0	10.2±0.3	8.3	10	3.4	0.90±0.2	3.1	0.70±0.2
G	10.0	10.2±0.3	10.3	12.0	3.5	0.90±0.2	4.6	0.70±0.2

[Vibration-proof product]

< Size code : D, D8 >

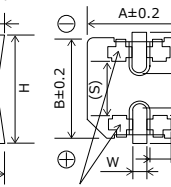
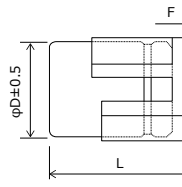

< Size code : F, G >

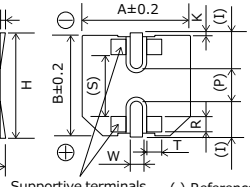
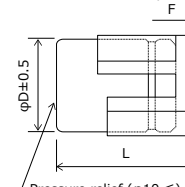

Size code	φD	L	A, B	H max.	F	I	W	P	K	R	S	T
D	6.3	6.1±0.3	6.6	7.8	0 to +0.15	2.4	0.65±0.1	2.2	0.35 ^{+0.15} _{-0.20}	1.1±0.2	3.3	1.05±0.2
D8	6.3	8.0±0.3	6.6	7.8	0 to +0.15	2.4	0.65±0.1	2.2	0.35 ^{+0.15} _{-0.20}	1.1±0.2	3.3	1.05±0.2
F	8.0	10.5±0.3	8.3	10.0	0 to +0.15	3.4	1.2±0.2	3.1	0.70±0.2	0.70±0.2	5.3	1.3±0.2
G	10.0	10.5±0.3	10.3	12.0	0 to +0.15	3.5	1.2±0.2	4.6	0.70±0.2	0.70±0.2	6.9	1.3±0.2

Characteristics list

Endurance : 125 °C 4000 h

Rated voltage (V)	Capacitance (±20 %) (μF)	Case size (mm)			Size code	Specification			Part number		Min. packaging q'ty
		φD	L			Ripple current*1 (mA rms)	ESR*2 (mΩ)	tan δ*3	Standard Product	Vibration-proof product	Taping (pcs)
			Standard	Vibration-proof							
25	47	5.0	5.8	-	C	850	80	0.14	EEHZK1E470R	-	1000
	68	6.3	5.8	6.1	D	1300	50	0.14	EEHZK1E680P	EEHZK1E680V	1000
	NEW 82	6.3	5.8	6.1	D	1300	50	0.14	EEHZK1E820P	EEHZK1E820V	1000
	150	6.3	7.7	8.0	D8	1800	30	0.14	EEHZK1E151XP	EEHZK1E151XV	900
	270	8.0	10.2	10.5	F	2000	27	0.14	EEHZK1E271P	EEHZK1E271V	500
	470	10.0	10.2	10.5	G	2800	20	0.14	EEHZK1E471P	EEHZK1E471V	500
35	33	5.0	5.8	-	C	750	100	0.12	EEHZK1V330R	-	1000
	56	6.3	5.8	6.1	D	1200	60	0.12	EEHZK1V560P	EEHZK1V560V	1000
	100	6.3	7.7	8.0	D8	1700	35	0.12	EEHZK1V101XP	EEHZK1V101XV	900
	180	8.0	10.2	10.5	F	2000	27	0.12	EEHZK1V181P	EEHZK1V181V	500
	330	10.0	10.2	10.5	G	2800	20	0.12	EEHZK1V331P	EEHZK1V331V	500

*1: Ripple current (100 kHz / +125 °C)

*2: ESR (100 kHz / +20 °C)

*3: tan δ (120 Hz / +20 °C)

◆ Please refer to the page of "Reflow profile" and "The taping dimensions".

◆ The dimensions of the vibration-proof products, please refer to the page of the mounting specification.

Frequency correction factor for ripple current

Rated capacitance (C)	Frequency (f)	100 Hz ≤ f < 200 Hz	200 Hz ≤ f < 300 Hz	300 Hz ≤ f < 500 Hz	500 Hz ≤ f < 1 kHz
C < 47 μF	Correction factor	0.15	0.20	0.25	0.35
47 μF ≤ C < 100 μF		0.15	0.25	0.30	0.40
100 μF ≤ C		0.15	0.25	0.30	0.40
Rated capacitance (C)	Frequency (f)	1 kHz ≤ f < 2 kHz	2 kHz ≤ f < 3 kHz	3 kHz ≤ f < 5 kHz	5 kHz ≤ f < 10 kHz
C < 47 μF	Correction factor	0.45	0.55	0.60	0.65
47 μF ≤ C < 100 μF		0.50	0.60	0.65	0.70
100 μF ≤ C		0.50	0.60	0.65	0.70
Rated capacitance (C)	Frequency (f)	10 kHz ≤ f < 15 kHz	15 kHz ≤ f < 20 kHz	20 kHz ≤ f < 30 kHz	30 kHz ≤ f < 40 kHz
C < 47 μF	Correction factor	0.70	0.75	0.75	0.75
47 μF ≤ C < 100 μF		0.75	0.75	0.80	0.80
100 μF ≤ C		0.75	0.80	0.85	0.85
Rated capacitance (C)	Frequency (f)	40 kHz ≤ f < 50 kHz	50 kHz ≤ f < 100 kHz	100 kHz ≤ f < 500 kHz	500 kHz ≤ f
C < 47 μF	Correction factor	0.80	0.85	1.00	1.05
47 μF ≤ C < 100 μF		0.85	0.90	1.00	1.00
100 μF ≤ C		0.85	0.90	1.00	1.00

Surface Mount Type

ZKU series V type

High temperature lead-free reflow



Hybrid

Features

- Endurance : 4000 h at 125 °C (High temperature / Long life)
- Large capacitance compared with ZK series
- Low ESR (85 % over, Lower ESR than Current V-TP), Low LC (0.01 CV or 3 μA)
- Equivalent to conductive polymer type Aluminum Electrolytic Capacitor (There are little characteristics change by temperature and frequency)
- Vibration-proof product is available upon request. (φ6.3, φ8, φ10)
- AEC-Q200 compliant
- RoHS compliant

Specifications

Size code	C	D	D8	F	G
Category temp. range	-55 °C to +125 °C				
Rated voltage range	25 V to 35 V				
Nominal cap.range	39 μF to 56 μF	68 μF to 100 μF	120 μF to 180 μF	220 μF to 330 μF	390 μF to 560 μF
Capacitance tolerance	±20 % (120 Hz / +20 °C)				
DC leakage current	I ≤ 0.01 CV or 3 (μA) After 2 minutes (whichever is greater)				
Dissipation factor (tan δ)	Please see the attached characteristics list				
Endurance	+125 °C ± 2 °C 4000 h, apply the rated ripple current without exceeding the rated voltage.				
	Capacitance change	Within ±30% of the initial value			
	Dissipation factor (tan δ)	≤ 200 % of the initial limit			
	ESR	≤ 200 % of the initial limit			
	DC leakage current	Within the initial limit			
ESR after endurance (Ω / 100 kHz)(-40 °C)	Size code				
	C	D	D8	F	G
	2.0	1.4	0.8	0.4	0.3
Shelf life	After storage for 1000 hours at +125 °C ± 2 °C with no voltage applied and then being stabilized at +20 °C, capacitors shall meet the limits specified in endurance. (With voltage treatment)				
Damp heat (Load)	+85 °C ± 2 °C, 85 % to 90 %, 2000 h, rated voltage applied				
	Capacitance change	Within ±30% of the initial value			
	Dissipation factor (tan δ)	≤ 200 % of the initial limit			
	ESR	≤ 200 % of the initial limit			
DC leakage current	Within the initial limit				

Marking

Example : 25 V 56 μF
Marking color : BLACK

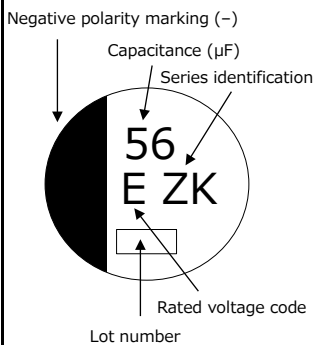

R. voltage code	Unit : V
E	25
V	35

Dimensions (not to scale)

[Standard]

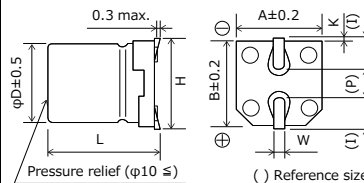

Unit : mm

Size code	φD	L	A, B	H max.	I	W	P	K
C	5.0	5.8±0.3	5.3	6.5	2.2	0.65±0.1	1.5	0.35 ^{+0.15} _{-0.20}
D	6.3	5.8±0.3	6.6	7.8	2.6	0.65±0.1	1.8	0.35 ^{+0.15} _{-0.20}
D8	6.3	7.7±0.3	6.6	7.8	2.6	0.65±0.1	1.8	0.35 ^{+0.15} _{-0.20}
F	8.0	10.2±0.3	8.3	10	3.4	0.90±0.2	3.1	0.70±0.2
G	10.0	10.2±0.3	10.3	12.0	3.5	0.90±0.2	4.6	0.70±0.2

[Vibration-proof product]

< Size code : D, D8 >

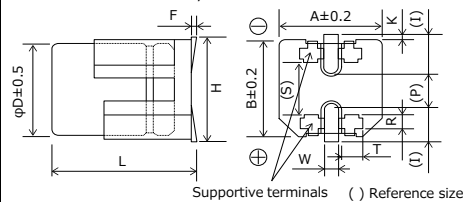

< Size code : F, G >

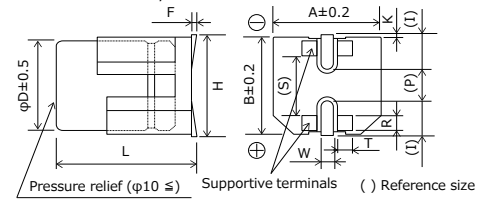

Unit : mm

Size code	φD	L	A, B	H max.	F	I	W	P	K	R	S	T
D	6.3	6.1±0.3	6.6	7.8	0 to +0.15	2.4	0.65±0.1	2.2	0.35 ^{+0.15} _{-0.20}	1.1±0.2	3.3	1.05±0.2
D8	6.3	8.0±0.3	6.6	7.8	0 to +0.15	2.4	0.65±0.1	2.2	0.35 ^{+0.15} _{-0.20}	1.1±0.2	3.3	1.05±0.2
F	8.0	10.5±0.3	8.3	10.0	0 to +0.15	3.4	1.2±0.2	3.1	0.70±0.2	0.70±0.2	5.3	1.3±0.2
G	10.0	10.5±0.3	10.3	12.0	0 to +0.15	3.5	1.2±0.2	4.6	0.70±0.2	0.70±0.2	6.9	1.3±0.2

Characteristics list

Endurance : 125 °C 4000 h

Rated voltage (V)	Capacitance (±20 %) (μF)	Case size (mm)			Size code	Specification			Part number		Min. packaging q'ty
		φD	L			Ripple current*1 (mA rms)	ESR*2 (mΩ)	tan δ*3	Standard Product	Vibration-proof product	Taping (pcs)
			Standard	Vibration-proof							
25	56	5	5.8	-	C	850	80	0.14	EEHZK1E560UR	-	1000
	100	6.3	5.8	6.1	D	1300	50	0.14	EEHZK1E101UP	EEHZK1E101UV	1000
	180	6.3	7.7	8.0	D8	1800	30	0.14	EEHZKE181XUP	EEHZKE181XUV	900
	330	8	10.2	10.5	F	2000	27	0.14	EEHZK1E331UP	EEHZK1E331UV	500
	560	10	10.2	10.5	G	2800	20	0.14	EEHZK1E561UP	EEHZK1E561UV	500
35	39	5	5.8	-	C	750	100	0.12	EEHZK1V390UR	-	1000
	68	6.3	5.8	6.1	D	1200	60	0.12	EEHZK1V680UP	EEHZK1V680UV	1000
	120	6.3	7.7	8.0	D8	1700	35	0.12	EEHZKV121XUP	EEHZKV121XUV	900
	220	8	10.2	10.5	F	2000	27	0.12	EEHZK1V221UP	EEHZK1V221UV	500
	390	10	10.2	10.5	G	2800	20	0.12	EEHZK1V391UP	EEHZK1V391UV	500

*1: Ripple current (100 kHz / +125 °C)

*2: ESR (100 kHz / +20 °C)

*3: tan δ (120 Hz / +20 °C)

◆ Please refer to the page of "Reflow profile" and "The taping dimensions".

◆ The dimensions of the vibration-proof products, please refer to the page of the mounting specification.

Frequency correction factor for ripple current

Rated capacitance (C)	Frequency(f)	100 Hz ≤ f < 200 Hz	200 Hz ≤ f < 300 Hz	300 Hz ≤ f < 500 Hz	500 Hz ≤ f < 1 kHz
C < 47 μF	Correction factor	0.15	0.20	0.25	0.35
47 μF ≤ C < 100 μF		0.15	0.25	0.30	0.40
100 μF ≤ C		0.15	0.25	0.30	0.40
Rated capacitance (C)	Frequency(f)	1 kHz ≤ f < 2 kHz	2 kHz ≤ f < 3 kHz	3 kHz ≤ f < 5 kHz	5 kHz ≤ f < 10 kHz
C < 47 μF	Correction factor	0.45	0.55	0.60	0.65
47 μF ≤ C < 100 μF		0.50	0.60	0.65	0.70
100 μF ≤ C		0.50	0.60	0.65	0.70
Rated capacitance (C)	Frequency(f)	10 kHz ≤ f < 15 kHz	15 kHz ≤ f < 20 kHz	20 kHz ≤ f < 30 kHz	30 kHz ≤ f < 40 kHz
C < 47 μF	Correction factor	0.70	0.75	0.75	0.75
47 μF ≤ C < 100 μF		0.75	0.75	0.80	0.80
100 μF ≤ C		0.75	0.80	0.85	0.85
Rated capacitance (C)	Frequency(f)	40 kHz ≤ f < 50 kHz	50 kHz ≤ f < 100 kHz	100 kHz ≤ f < 500 kHz	500 kHz ≤ f
C < 47 μF	Correction factor	0.80	0.85	1.00	1.05
47 μF ≤ C < 100 μF		0.85	0.90	1.00	1.00
100 μF ≤ C		0.85	0.90	1.00	1.00

Surface Mount Type

ZE series V type
High temperature lead-free reflow



Hybrid

Features

- Endurance: 2000 h at 145 °C (High temperature / Long life)
- Low ESR and high ripple current (85 % over, Lower ESR than current V-TP)
- High-withstand voltage (to 63 V), Low LC (0.01 CV or 3 μA)
- Equivalent to conductive polymer type aluminum electrolytic capacitor (There are little characteristics change by temperature and frequency)
- Vibration-proof product is available upon request. (φ8 mm and larger)
- AEC-Q200 compliant
- RoHS compliant

Specifications

Size code	F	G
Category temp. range	-55 °C to +145 °C	
Rated voltage range	25 V to 63 V	
Nominal cap.range	33 μF to 220 μF	56 μF to 330 μF
Capacitance tolerance	±20 % (120 Hz / +20 °C)	
DC leakage current	I ≤ 0.01 CV or 3 (μA) After 2 minutes (whichever is greater)	
Dissipation factor (tan δ)	Please see the attached characteristics list	
Endurance 1	+145 °C ± 2 °C, 2000 h, apply the rated ripple current without exceeding the rated voltage	
	Capacitance change	Within ±30% of the initial value
	Dissipation factor (tan δ)	≤ 200 % of the initial limit
	E.S.R.	≤ 200 % of the initial limit
Endurance 2	+135 °C ± 2 °C, 4000 h, apply the rated ripple current without exceeding the rated voltage	
	Capacitance change	Within ±30% of the initial value
	Dissipation factor (tan δ)	≤ 200 % of the initial limit
	E.S.R.	≤ 200 % of the initial limit
Shelf life	After storage for 1000 hours at +145 °C ± 2 °C with no voltage applied and then being stabilized at +20 °C, capacitors shall meet the limits specified in endurance 1. (With voltage treatment)	
	85 °C ± 2 °C, 85 % to 90 %, 2000 h, rated voltage applied	
Damp heat (Load)	Capacitance change	
	Dissipation factor (tan δ)	
	E.S.R.	
	DC leakage current	
Resistance to soldering heat	After reflow soldering and then being stabilized at +20 °C, capacitors shall meet the following limits.	
	Capacitance change	
	Dissipation factor (tan δ)	
	DC leakage current	

Marking

Example : 25 V 220 μF
Marking color : BLACK

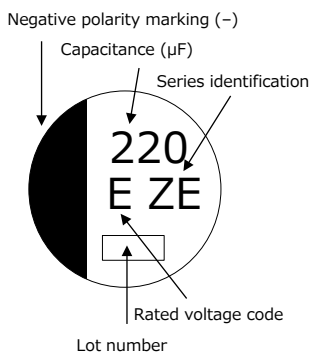

R. voltage code	Unit : V
E	25
V	35
H	50
J	63

Dimensions (not to scale)

[Standard]

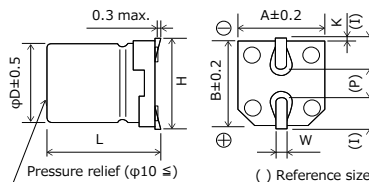

Size code	φD	L	A, B	H max.	I	W	P	K
F	8.0	10.2±0.3	8.3	10	3.4	0.90±0.2	3.1	0.70±0.2
G	10.0	10.2±0.3	10.3	12.0	3.5	0.90±0.2	4.6	0.70±0.2

[Vibration-proof product]

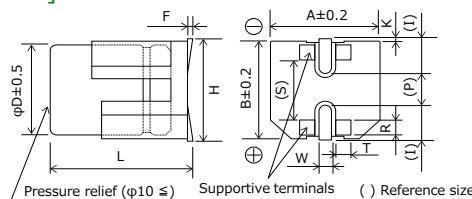

Size code	φD	L	A, B	H max.	F	I	W	P	K	R	S	T
F	8.0	10.5±0.3	8.3	10.0	0 to +0.15	3.4	1.2±0.2	3.1	0.70±0.2	0.70±0.2	5.3	1.3±0.2
G	10.0	10.5±0.3	10.3	12.0	0 to +0.15	3.5	1.2±0.2	4.6	0.70±0.2	0.70±0.2	6.9	1.3±0.2

Characteristics list

Endurance 1 : 145 °C 2000 h

Endurance 2 : 135 °C 4000 h

Rated voltage (V)	Capacitance (±20 %) (μF)	Case size (mm)			Size code	Specification				Part number		Min. packaging q'ty
		φD	L			Ripple current *1 (mA rms)	ESR*2 (mΩ)	tan δ*3	Standard product	Vibration-proof product		
			Standard	Vibration-proof							Endurance 1 (+145°C)	Endurance 2 (+135°C)
25	220	8.0	10.2	10.5	F	700	1600	27	0.14	EEHZE1E221P	EEHZE1E221V	500
	330	10.0	10.2	10.5	G	900	2000	20	0.14	EEHZE1E331P	EEHZE1E331V	500
35	150	8.0	10.2	10.5	F	700	1600	27	0.12	EEHZE1V151P	EEHZE1V151V	500
	270	10.0	10.2	10.5	G	900	2000	20	0.12	EEHZE1V271P	EEHZE1V271V	500
50	68	8.0	10.2	10.5	F	600	1250	30	0.10	EEHZE1H680P	EEHZE1H680V	500
	100	10.0	10.2	10.5	G	800	1600	28	0.10	EEHZE1H101P	EEHZE1H101V	500
63	33	8.0	10.2	10.5	F	600	1100	40	0.08	EEHZE1J330P	EEHZE1J330V	500
	56	10.0	10.2	10.5	G	800	1400	30	0.08	EEHZE1J560P	EEHZE1J560V	500
NEW	82	10.0	10.2	10.5	G	800	1400	30	0.08	EEHZE1J820P	EEHZE1J820V	500

*1: Ripple current (100 kHz / +145 °C or +135°C)

*2: ESR (100 kHz / +20 °C)

*3: tan δ (120 Hz / +20 °C)

◆ Please refer to the page of "Reflow profile" and "The taping dimensions".

◆ The dimensions of the vibration-proof products, please refer to the page of the mounting specification.

Frequency correction factor for ripple current

Rated capacitance (C)	Frequency (f)	100 Hz ≤ f < 200 Hz	200 Hz ≤ f < 300 Hz	300 Hz ≤ f < 500 Hz	500 Hz ≤ f < 1 kHz
C < 47 μF	Correction factor	0.10	0.10	0.15	0.20
47 μF ≤ C < 150 μF		0.15	0.20	0.25	0.30
150 μF ≤ C		0.15	0.25	0.25	0.30

Rated capacitance (C)	Frequency (f)	1 kHz ≤ f < 2 kHz	2 kHz ≤ f < 3 kHz	3 kHz ≤ f < 5 kHz	5 kHz ≤ f < 10 kHz
C < 47 μF	Correction factor	0.30	0.40	0.45	0.50
47 μF ≤ C < 150 μF		0.40	0.45	0.55	0.60
150 μF ≤ C		0.45	0.50	0.60	0.65

Rated capacitance (C)	Frequency (f)	10 kHz ≤ f < 15 kHz	15 kHz ≤ f < 20 kHz	20 kHz ≤ f < 30 kHz	30 kHz ≤ f < 40 kHz
C < 47 μF	Correction factor	0.60	0.65	0.70	0.75
47 μF ≤ C < 150 μF		0.70	0.75	0.80	0.80
150 μF ≤ C		0.75	0.80	0.85	0.85

Rated capacitance (C)	Frequency (f)	40 kHz ≤ f < 50 kHz	50 kHz ≤ f < 100 kHz	100 kHz ≤ f < 500 kHz	500 kHz ≤ f
C < 47 μF	Correction factor	0.80	0.85	1.00	1.05
47 μF ≤ C < 150 μF		0.85	0.90	1.00	1.00
150 μF ≤ C		0.85	0.90	1.00	1.00

After endurance ESR (100 kHz, -40°C)

Size	φ8 x L10.2	φ10 x L10.2
ESR (Ω)	0.4	0.3

Surface Mount Type

ZS series **V** type

High temperature lead-free reflow



Hybrid

Features

- High ripple current and Large capacitance compared with ZC series
- Endurance: 4000 h at 125 °C
- Equivalent to conductive polymer type Aluminum Electrolytic Capacitor (There are little characteristics change by temperature and frequency)
- Vibration-proof product is available upon request.
- AEC-Q200 compliant
- RoHS compliant

Specifications

Size code	G16	
Category temp. range	-55 °C to +125 °C	
Rated voltage range	25 V to 63 V	
Nominal cap.range	150 μF to 560 μF	
Capacitance tolerance	±20 % (120 Hz / +20 °C)	
DC leakage current	I ≤ 0.01 CV or 3 (μA) After 2 minutes (whichever is greater)	
Dissipation factor (tan δ)	Please see the attached characteristics list	
Endurance	+125 °C ± 2 °C, 4000 h, apply the rated ripple current without exceeding the rated voltage.	
	Capacitance change	Within ±30% of the initial value
	Dissipation factor (tan δ)	≤ 200 % of the initial limit
	E.S.R.	≤ 200 % of the initial limit
	DC leakage current	Within the initial limit
ESR after endurance (Ω / 100 kHz)(-40 °C)	Size code	
	G16	0.3
Shelf life	After storage for 1000 hours at +125 °C ± 2 °C with no voltage applied and then being stabilized at +20°C, capacitors shall meet the limits specified in endurance. (With voltage treatment)	
Damp heat (Load)	+85 °C ± 2 °C, 85 % to 90 %, 2000 h, rated voltage applied.	
	Capacitance change	Within ±30% of the initial value
	Dissipation factor (tan δ)	≤ 200 % of the initial limit
	E.S.R.	≤ 200 % of the initial limit
	DC leakage current	Within the initial limit
Resistance to soldering heat	After reflow soldering and then being stabilized at +20°C, capacitors shall meet the following limits.	
	Capacitance change	Within ±10% of the initial value
	Dissipation factor (tan δ)	Within the initial limit
	DC leakage current	Within the initial limit

Marking

Example : 35 V 470 μF
Marking color : BLACK

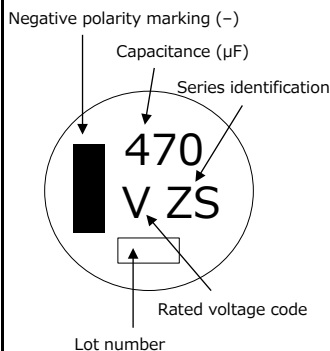

R. voltage code	Unit : V
E	25
V	35
H	50
J	63

Dimensions (not to scale)

[Standard]

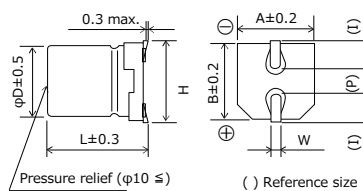

Size code	φD	L	A, B	H	I	W	P
G16	10.0	16.5	10.3	11.0±0.2	3.2	1.2±0.2	4.6

Unit : mm

[Vibration-proof product]

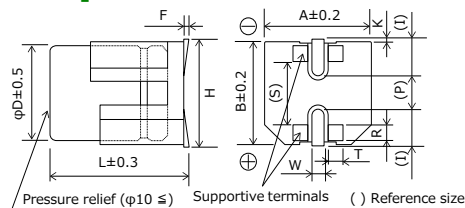

Size code	φD	L	A, B	H	F	I	W	P	K	R	S	T
G16	10.0	16.8	10.3	11.0±0.2	0 to +0.15	3.2	1.2±0.2	4.6	-	0.70±0.2	6.9	1.3±0.2

Unit : mm

Characteristics list

Endurance : 125 °C 4000 h

Rated voltage (V)	Capacitance (±20 %) (μF)	Case size (mm)			Size code	Specification			Part number		Min. packaging q'ty
		φD	L			Ripple current*1 (mA rms)	ESR*2 (mΩ)	tan δ*3	Standard Product	Vibration-proof product	Taping (pcs)
			Standard	Vibration-proof							
25	560	10.0	16.5	16.8	G16	4000	11	0.14	EEHZS1E561P	EEHZS1E561V	250
35	470	10.0	16.5	16.8	G16	4000	11	0.12	EEHZS1V471P	EEHZS1V471V	250
50	220	10.0	16.5	16.8	G16	3700	13	0.10	EEHZS1H221P	EEHZS1H221V	250
63	150	10.0	16.5	16.8	G16	3500	15	0.08	EEHZS1J151P	EEHZS1J151V	250

*1: Ripple current (100 kHz / +125 °C)

*2: ESR (100 kHz / +20 °C)

*3: tan δ (120 Hz / +20 °C)

◆ Please refer to the page of "Reflow profile" and "The taping dimensions".

◆ The dimensions of the vibration-proof products, please refer to the page of the mounting specification.

Frequency correction factor for ripple current

Rated capacitance (C)	Frequency (f)	100 Hz ≤ f < 200 Hz	200 Hz ≤ f < 300 Hz	300 Hz ≤ f < 500 Hz	500 Hz ≤ f < 1 kHz
100 μF ≤ C < 150 μF	Correction factor	0.15	0.20	0.25	0.30
150 μF ≤ C		0.15	0.25	0.25	0.30

Rated capacitance (C)	Frequency (f)	1 kHz ≤ f < 2 kHz	2 kHz ≤ f < 3 kHz	3 kHz ≤ f < 5 kHz	5 kHz ≤ f < 10 kHz
100 μF ≤ C < 150 μF	Correction factor	0.40	0.45	0.55	0.60
150 μF ≤ C		0.45	0.50	0.60	0.65

Rated capacitance (C)	Frequency (f)	10 kHz ≤ f < 15 kHz	15 kHz ≤ f < 20 kHz	20 kHz ≤ f < 30 kHz	30 kHz ≤ f < 40 kHz
100 μF ≤ C < 150 μF	Correction factor	0.70	0.75	0.80	0.80
150 μF ≤ C		0.75	0.80	0.85	0.85

Rated capacitance (C)	Frequency (f)	40 kHz ≤ f < 50 kHz	50 kHz ≤ f < 100 kHz	100 kHz ≤ f < 500 kHz	500 kHz ≤ f
100 μF ≤ C < 150 μF	Correction factor	0.85	0.90	1.00	1.00
150 μF ≤ C		0.85	0.90	1.00	1.00

Radial Lead type

ZF series A type



Hybrid

Features

- Endurance : 1000 h at 150 °C (High temperature)
- High temperature compared with ZC series
- High-withstand voltage (to 63 V), Low LC (0.01 CV or 3 μA)
- Equivalent to conductive polymer type Aluminum Electrolytic Capacitor
(There are little characteristics change by temperature and frequency)
- AEC-Q200 compliant
- RoHS compliant

Specifications

Size code	F	G
Category temp. range	-55 °C to +150 °C	
Rated voltage range	25 V to 63 V	
Nominal cap.range	33 μF to 150 μF	56 μF to 270 μF
Capacitance tolerance	±20 % (120 Hz / +20°C)	
DC leakage current	I ≤ 0.01 CV or 3 (μA) After 2 minutes (whichever is greater)	
Dissipation factor (tan δ)	Please see the attached characteristics list	
Endurance	+150 °C ± 2 °C, 1000 h, apply the rated ripple current without exceeding the rated voltage.	
	Capacitance change	Within ±30% of the initial value
	Dissipation factor (tan δ)	≤ 200 % of the initial limit
	ESR	≤ 200 % of the initial limit
	DC leakage current	Within the initial limit
ESR after endurance (Ω / 100 kHz)(-40 °C)	Size code	
	F	G
	0.4	0.3
Shelf life	After storage for 1000 hours at +150 °C ± 2 °C with no voltage applied and then being stabilized at +20 °C, capacitors shall meet the limits specified in endurance. (With voltage treatment)	
Damp heat (Load)	+85 °C ± 2 °C, 85 % to 90 %, 2000 h, rated voltage applied	
	Capacitance change	Within ±30% of the initial value
	Dissipation factor (tan δ)	≤ 200 % of the initial limit
	ESR	≤ 200 % of the initial limit
DC leakage current	Within the initial limit	

Marking

Example : 25 V 270 μF
Marking color : BLACK

Negative polarity marking (-)

Capacitance (μF)

Series identification

Rated voltage code

Lot number

R. voltage code	Unit : V
E	25
V	35

H	50
J	63

Dimensions (not to scale)

Size code	φD	L	φd	F
F	8.0	9.5	0.6	3.5
G	10.0	9.5	0.6	5.0

Unit : mm

Characteristics list

Endurance : 150 °C 1000 h

Rated voltage (V)	Capacitance (±20 %) (μF)	Case size (mm)		Size code	Specification			Part number	Min. packaging q'ty
		φD	L		Ripple current * ¹ (mA rms)	ESR* ² (mΩ)	tan δ* ³		Long lead (pcs)
25	150	8.0	9.5	F	800	27	0.14	EEHAZF1E151	200
	270	10.0	9.5	G	1000	20	0.14	EEHAZF1E271	200
35	100	8.0	9.5	F	770	30	0.12	EEHAZF1V101	200
	150	10.0	9.5	G	950	23	0.12	EEHAZF1V151	200
50	56	8.0	9.5	F	700	35	0.10	EEHAZF1H560	200
	100	10.0	9.5	G	900	28	0.10	EEHAZF1H101	200
63	33	8.0	9.5	F	650	40	0.08	EEHAZF1J330	200
	56	10.0	9.5	G	840	30	0.08	EEHAZF1J560	200

*1: Ripple current (100 kHz / +150 °C)

*2: ESR (100 kHz / +20 °C)

*3: tan δ (120 Hz / +20 °C)

Frequency correction factor for ripple current

Rated capacitance (C)	Frequency (f)	100 Hz ≤ f < 200 Hz	200 Hz ≤ f < 300 Hz	300 Hz ≤ f < 500 Hz	500 Hz ≤ f < 1 kHz
C < 47 μF	Correction factor	0.10	0.10	0.15	0.20
47 μF ≤ C < 150 μF		0.15	0.20	0.25	0.30
150 μF ≤ C		0.15	0.25	0.25	0.30
Rated capacitance (C)	Frequency (f)	1 kHz ≤ f < 2 kHz	2 kHz ≤ f < 3 kHz	3 kHz ≤ f < 5 kHz	5 kHz ≤ f < 10 kHz
C < 47 μF	Correction factor	0.30	0.40	0.45	0.50
47 μF ≤ C < 150 μF		0.40	0.45	0.55	0.60
150 μF ≤ C		0.45	0.50	0.60	0.65
Rated capacitance (C)	Frequency (f)	10 kHz ≤ f < 15 kHz	15 kHz ≤ f < 20 kHz	20 kHz ≤ f < 30 kHz	30 kHz ≤ f < 40 kHz
C < 47 μF	Correction factor	0.60	0.65	0.70	0.75
47 μF ≤ C < 150 μF		0.70	0.75	0.80	0.80
150 μF ≤ C		0.75	0.80	0.85	0.85
Rated capacitance (C)	Frequency (f)	40 kHz ≤ f < 50 kHz	50 kHz ≤ f < 100 kHz	100 kHz ≤ f < 500 kHz	500 kHz ≤ f
C < 47 μF	Correction factor	0.80	0.85	1.00	1.05
47 μF ≤ C < 150 μF		0.85	0.90	1.00	1.00
150 μF ≤ C		0.85	0.90	1.00	1.00

CAUTION AND WARNING

1. The electronic components contained in this catalog are designed and produced for use in home electric appliances, office equipment, information equipment, communications equipment, and other general purpose electronic devices.
Before use of any of these components for equipment that requires a high degree of safety, such as medical instruments, aerospace equipment, disaster-prevention equipment, security equipment, vehicles (automobile, train, vessel), please be sure to contact our sales representative corporation.
2. When applying one of these components for equipment requiring a high degree of safety, no matter what sort of application it might be, be sure to install a protective circuit or redundancy arrangement to enhance the safety of your equipment. In addition, please carry out the safety test on your own responsibility.
3. When using our products, no matter what sort of equipment they might be used for, be sure to make a written agreement on the specifications with us in advance.
4. Technical information contained in this catalog is intended to convey examples of typical performances and or applications and is not intended to make any warranty with respect to the intellectual property rights or any other related rights of our company or any third parties nor grant any license under such rights.
5. In order to export products in this catalog, the exporter may be subject to the export license requirement under the Foreign Exchange and Foreign Trade Law of Japan.
6. No ozone-depleting substances (ODSs) under the Montreal Protocol are used in the manufacturing processes of Automotive & Industrial Systems Company, Panasonic Corporation.

● Please contact _____

● Factory _____

Device Solutions Business Division
Industrial Solutions Company

Panasonic[®]

1006 Kadoma, Kadoma City, Osaka 571-8506,
JAPAN

The information in this catalog is valid as of December 2019.