

## SMI MEDIUM PRESSURE DIGITAL / ANALOG SENSOR

### SM4000/SM1000 Series

### Gage & Differential Pressure Sensors

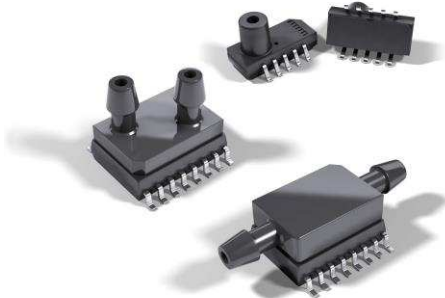

#### Features

- Pressure ranges:  
from 2.5 up to 30 PSI
- Pressure type:
  - ✓ gage
  - ✓ differential
  - ✓ asymmetric differential
- 16-bit I<sup>2</sup>C digital and analog output interface available
- Total error band
  - ✓  $\pm 1\%$  FS (digital)
  - ✓  $\pm 1.5\%$  FS (analog)
- Pressure calibrated and temperature compensated output
- Compensated temperature range:  
-20 to 85°C

#### Applications

- Patient Monitoring
- Ventilators
- Gas Flow Instrumentation
- Air Flow Measurement
- Liquid Level Measurement
- Pressure Transmitters
- Pneumatic Gauges
- Pressure Switches
- Safety Cabinets

The SM4000/SM1000 are medium pressure MEMS sensors offering state-of-the-art pressure transducer technology and CMOS mixed signal processing technology to produce either an analog and/or digital output fully conditioned, multi-order pressure and temperature compensated. This series provide a JEDEC standard SOIC-16 package with vertical or horizontal porting options or a JEDEC SOIC-10 package with a vertical port. It is available in gage, differential and asymmetric differential configurations. With the dual porting, a reference measurement is possible to minimize errors due to changes in ambient pressure.

Combining the pressure sensor with a signal-conditioning ASIC in a single package simplifies the use of advanced silicon micro-machined pressure sensors. The pressure sensor can be mounted directly on a standard printed circuit board and a high level, calibrated pressure signal can be acquired from the digital interface. This eliminates the need for additional circuitry, such as a compensation network or microcontroller containing a custom correction algorithm.

Customer-specified pressure ranges and supply voltages are available.

The SM4000/SM1000 are shipped in sticks or tape & reel.



The SM4000 and SM1000 digital output only sensors earned the AccuStable quality label. The AccuStable brand stands for <1% total error band initially and <1% shift during operation over 10 year lifetime. Qualification is based on 1000 hours HTOL (High-temperature operating life) test at 85°C with 5V.

# MEDIUM PRESSURE DIGITAL AND ANALOG SENSOR

SM4000/SM1000 Series

## Performance Specification

### 1. Calibrated Pressure Ranges

Series	Pressure Type	Output Type	P <sub>MIN</sub> (PSI)	P <sub>MAX</sub> (PSI)
SM4291	Gage	Digital & Analog	0	+2.5 to +14.9
SM4231	Gage	Digital		
SM4391	Differential*	Digital & Analog	-2.5 to -14.9	+2.5 to +14.9
SM4331	Differential*	Digital		
SM4491	Asymmetric**	Digital & Analog	-14.9 to 0	0 to +14.9
SM4431	Asymmetric**	Digital		
SM1291	Gage	Digital & Analog	0	+15 to +30
SM1231	Gage	Digital		
SM1391	Differential*	Digital & Analog	-15 to -30	+15 to +30
SM1331	Differential*	Digital		
SM1491	Asymmetric**	Digital & Analog	-30 to 0	0 to +30
SM1431	Asymmetric**	Digital		

#### Comments:

\*For differential devices the absolute value of P<sub>MIN</sub> must match absolute value of P<sub>MAX</sub>.

\*\*For 4XXX asymmetric devices the delta between P<sub>MAX</sub> and P<sub>MIN</sub> must be at least 2 PSI.

\*\*\* For 1XXX asymmetric devices the delta between P<sub>MAX</sub> and P<sub>MIN</sub> must be at least 15 PSI.

### 2. Absolute Maximum Ratings

All parameters are specified at VDD = 3.3 V / 5.0 V supply voltage at 25°C, unless otherwise noted.

Characteristic	Symbol	Min	Max	Units
Compensated Temperature	T <sub>COMP</sub>	-20	85	°C
Operating Temperature <sup>(a)</sup>	T <sub>OP</sub>	-40	105	°C
Storage Temperature <sup>(a)</sup>	T <sub>STG</sub>	-40	125	°C
Supply Voltage	V <sub>DD</sub>	-0.3	6	V
Media Compatibility <sup>(a)</sup>		Clean, dry air compatible with wetted materials <sup>(b)</sup>		

#### Burst pressure and proof pressure by pressure range and series

Max Operating Pressure Range P <sub>MAX</sub> (PSI)	Series	Proof Pressure <sup>(a, c)</sup> P <sub>Burst</sub> (PSI)	Burst Pressure <sup>(a, d)</sup> P <sub>Proof</sub> (PSI)
2.5 to 7.5	4X91 and 4X31	25	40
7.5 to 15		45	75
15 to 30	1X91 and 1X31	45	75

#### Notes:

- Tested on a sample basis.
- Wetted materials include silicon, epoxy, RTV, gold and aluminum.
- Proof pressure is defined as the maximum pressure to which the device can be taken and still perform within specifications after returning to the operating pressure range.
- Burst pressure is the pressure at which the device suffers catastrophic failure resulting in pressure loss through the device.

### 3. ESD

All parameters are specified at VDD = 3.3 V / 5.0 V supply voltage at 25°C, unless otherwise noted.

Description	Condition	Symbol	Min	Max	Units
ESD HBM Protection at all Pins	AEC Q100-002 (HBM) chip level test	V <sub>ESD(HBM)</sub>	-2	+2	kV

## MEDIUM PRESSURE DIGITAL AND ANALOG SENSOR

SM4000/SM1000 Series

### 4. External Components

Description	Symbol	Min	Typ	Max	Units
Supply bypass capacitor	C <sub>VDD</sub>		100		nF

### 5. Recommended Operating Conditions

The recommended operating conditions must not be exceeded in order to provide proper functionality of the device. All parameters specified in the following sections refer to these recommended operating conditions unless stated otherwise.

Description	Symbol	Min	Typ	Max	Units
Supply Voltage	V <sub>DD</sub>	4.75	5.0	5.25	V
		3.0	0.3	3.6	
Low level input voltage at Digital I/O	V <sub>IN,I2C,lo</sub>	-0.3		0.9	V
High level input voltage at Digital I/O	V <sub>IN,I2C,hi</sub>	0.8 * V <sub>DD</sub>		V <sub>DD</sub> +0.3	V
Current Consumption with analog output (only applicable for XX91)			4.5		mA
Current Consumption without analog output			3		mA

### 6. Operating Characteristics Table

All parameters are specified at V<sub>DD</sub> = 3.3 V / 5.0 V supply voltage at 25°C, unless otherwise noted.

Characteristic	Series	Symbol	Min	Typ	Max	Units
Digital Pressure Output @ P <sub>MIN</sub> <sup>(e)</sup>	All	DOUT <sub>MIN</sub>		-26,215		Counts
Digital Pressure Output @ P <sub>MAX</sub> <sup>(e)</sup>		DOUT <sub>MAX</sub>		26,214		Counts
Digital Full Scale Span <sup>(e)</sup>		DFS		52,429		Counts
Resolution				16		Bits
Digital Output Total Error Band <sup>(f, g, h)</sup>		DACC	-1		+1	%FS
Analog Pressure Output @ P <sub>MIN</sub> <sup>(e)</sup>	XX91	AOUT <sub>MIN</sub>		10		%VDD
Analog Pressure Output @ P <sub>MAX</sub> <sup>(e)</sup>		AOUT <sub>MAX</sub>		90		%VDD
Analog Full Scale Span		AFS		80		%VDD
Analog Output Accuracy <sup>(f, g, h)</sup>		AACC	-1.5			+1.5

#### Notes:

- e) Only the typical values are shown here. However, the output values can be customized or changed upon request.
- f) The total error band specification applies across the compensated temperature range. This specification includes the combination of linearity, repeatability, and hysteresis errors over pressure, temperature, and voltage.
- g) Maximum 10-year zero pressure offset shift < ±2%FS based on 1000 hours of HTOL, TC and THB testing.
- h) For less demanding applications, devices with relaxed accuracy specifications are available.

## MEDIUM PRESSURE DIGITAL AND ANALOG SENSOR

SM4000/SM1000 Series

### 7. Digital Output Transfer Function

$$P_{\text{read}} = P_{\text{min}} + \frac{P_{\text{DOUT}_{\text{read}}} - P_{\text{DOUT}_{\text{min}}}}{P_{\text{DOUT}_{\text{max}}} - P_{\text{DOUT}_{\text{min}}}} (P_{\text{max}} - P_{\text{min}})$$

$$P_{\text{read}} = P_{\text{min}} + \frac{P_{\text{DOUT}_{\text{read}}} - P_{\text{DOUT}_{\text{min}}}}{P_{\text{DOUT}_{\text{max}}} - P_{\text{DOUT}_{\text{min}}}} (P_{\text{max}} - P_{\text{min}})$$

$P_{\text{min}}$  and  $P_{\text{max}}$  are minimum and maximum rating pressure in specified pressure unit on the specification.

$P_{\text{DOUT}_{\text{min}}}$  and  $P_{\text{DOUT}_{\text{max}}}$  are minimum and maximum digital counts on the specification.

$P_{\text{DOUT}_{\text{read}}}$  is digital reading from the output and  $P_{\text{read}}$  is the converted pressure output based on  $P_{\text{DOUT}_{\text{read}}}$ .

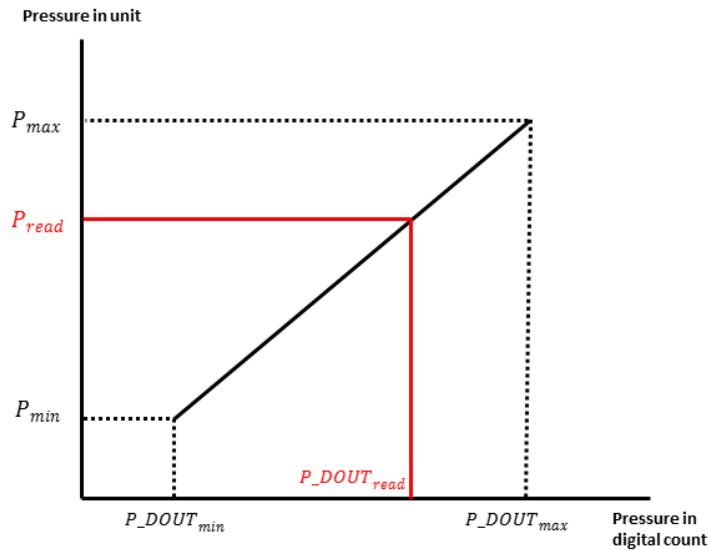

For example, the  $P_{\text{min}}$  and  $P_{\text{max}}$  for the sensor are specified as -15 psi and +15 psi. The  $\text{DOUT}_{\text{min}}$  and  $\text{DOUT}_{\text{max}}$  are 26214 and +26214. So,

$$P_{\text{read}} = -15 + \frac{\text{DOUT}_{\text{read}} + 26214}{52428} \times 30 \text{ psi}$$

# MEDIUM PRESSURE DIGITAL AND ANALOG SENSOR

SM4000/SM1000 Series

## 8. Package Reference

### SOIC-16 (C) Dual Vertical Package Dimensions

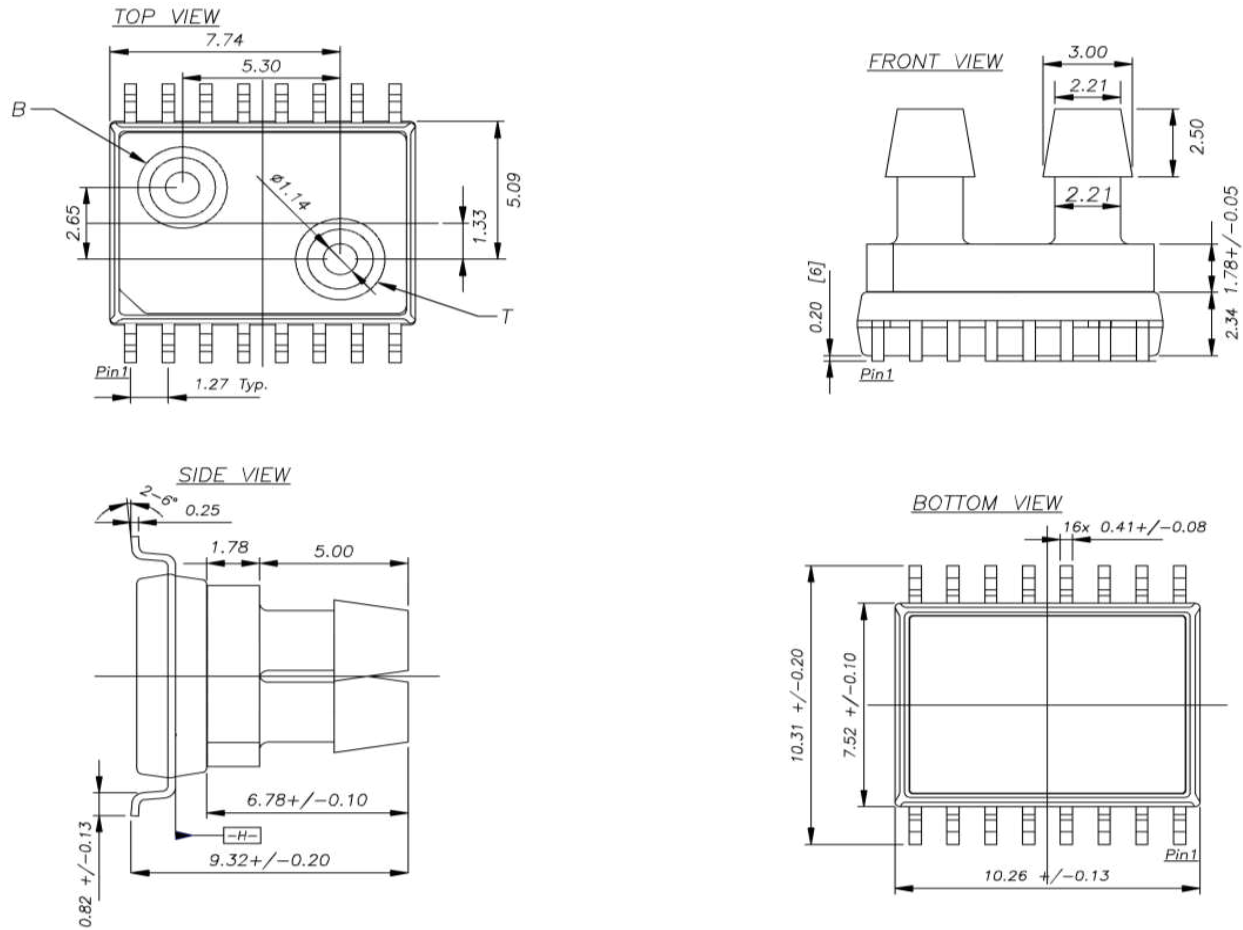

Lot number identification on top side

### Notes:

- All dimensions in units of [mm]
- Moisture Sensitivity Level (MSL): Level 3
- Wetted materials: Silicon, glass, gold, aluminum, copper, silicone, epoxy, mold compound.
- [B] is tube connected to bottom side of sensor die.
- [T] is tube connected to top side of sensor die. Topside pressure is positive pressure. An increase in topside pressure will result in an increase in sensor output.
- Bottom plate is stainless steel.
- Electrically isolate the bottom metal cover, do not connect to the cover and keep the board underneath free from electrical circuits.
- Robust JEDEC SOIC-16 package for automated assembly
- Manufactured according to ISO9001, ISO14001 and ISO/TS 16949 standards

# MEDIUM PRESSURE DIGITAL AND ANALOG SENSOR

SM4000/SM1000 Series

## SOIC-16 (C) Dual Horizontal Package Dimensions

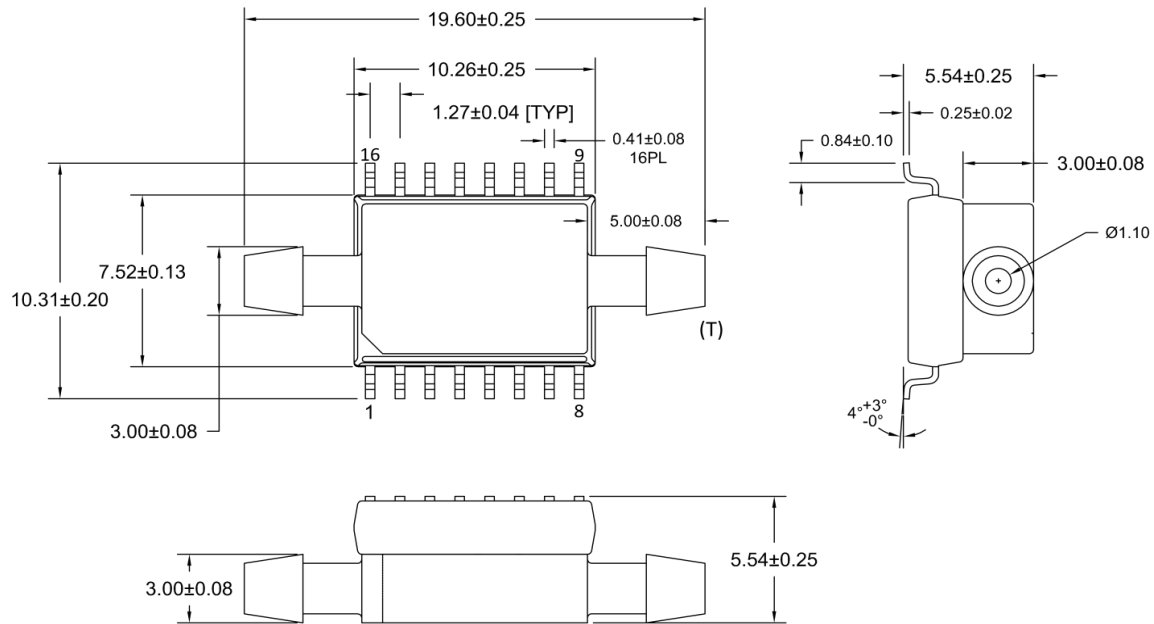

Dimensions are in mm

Lot number identification on top side

### Notes:

- All dimensions in units of [mm]
- Moisture Sensitivity Level (MSL): Level 3
- Wetted materials: Silicon, glass, gold, aluminum, copper, silicone, epoxy, mold compound.
- [B] is tube connected to bottom side of sensor die.
- [T] is tube connected to top side of sensor die. Topside pressure is positive pressure. An increase in topside pressure will result in an increase in sensor output.
- Bottom plate is stainless steel
- Robust JEDEC SOIC-16 package for automated assembly
- Electrically isolate the bottom metal cover, do not connect to the cover and keep the board underneath free from electrical circuits.
- Manufactured according to ISO9001, ISO14001 and ISO/TS 16949 standards

# MEDIUM PRESSURE DIGITAL AND ANALOG SENSOR

SM4000/SM1000 Series

## SOIC-10 Single Vertical Package Dimensions

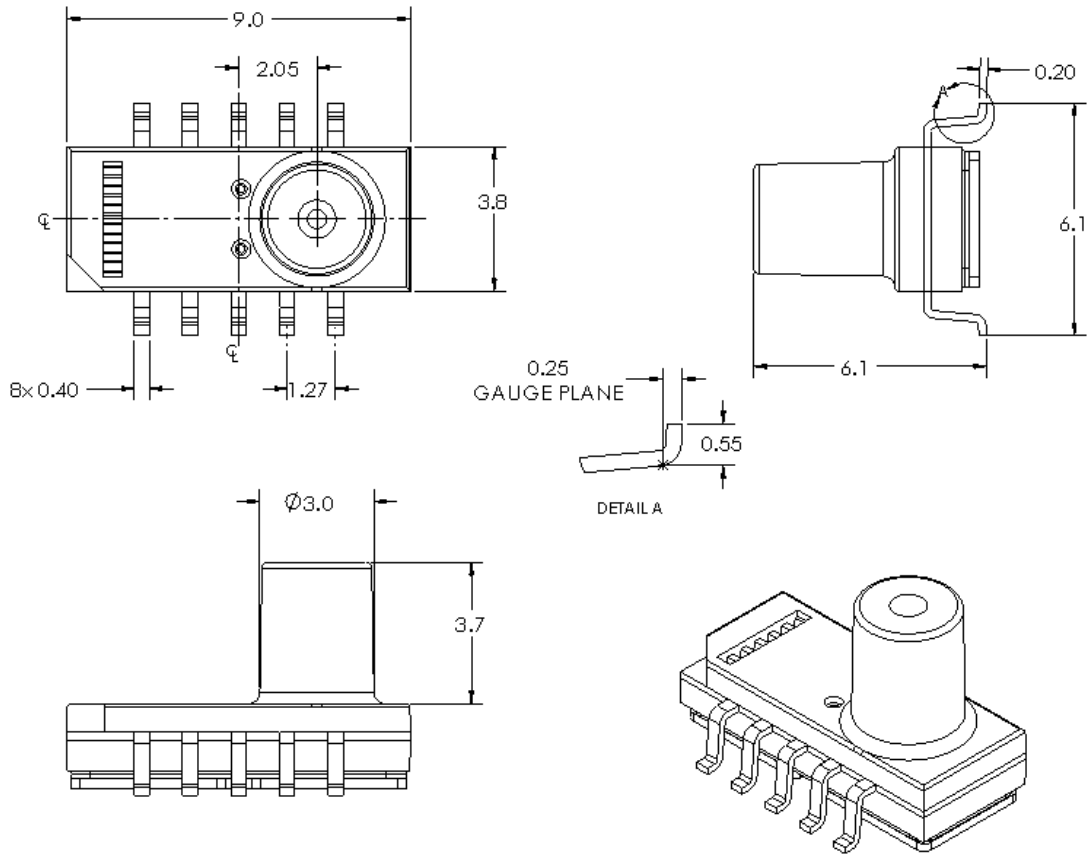

Lot number and part number identification on bottom side

### Notes:

- All dimensions in units of [mm]
- Moisture Sensitivity Level (MSL): Level 1
- Wetted materials: Silicon, RTV, plastic

# MEDIUM PRESSURE DIGITAL AND ANALOG SENSOR

SM4000/SM1000 Series

## Applications Circuit for SOIC-16 Package

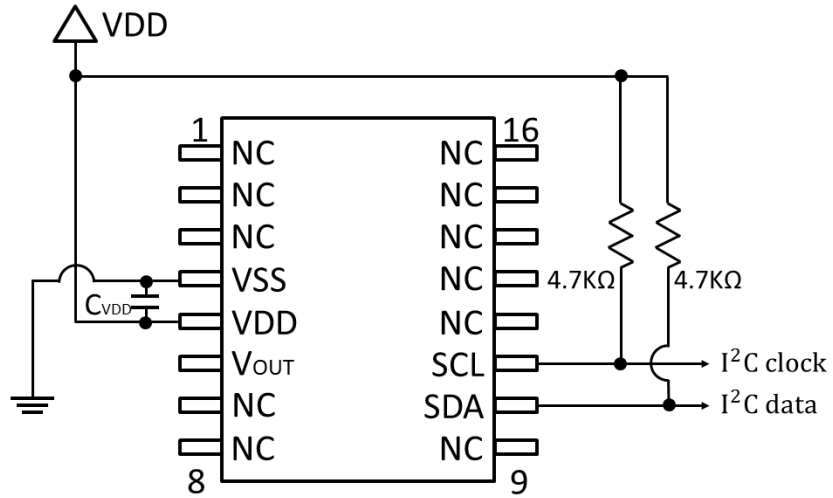

Pin No	Pin Function (XX91)	Pin Function (XX31)
1	NC (No Connect)	NC (No Connect)
2	NC	NC
3	NC	NC
4	VSS	VSS
5	VDD	VDD
6	VOUT (Analog Output)	NC
7	NC	NC
8	NC	NC
9	NC	NC
10	SDA	SDA
11	SCL	SCL
12	NC	NC
13	NC	NC
14	NC	NC
15	NC	NC
16	NC	NC

**Notes:**

- Do not connect to NC pins



# MEDIUM PRESSURE DIGITAL AND ANALOG SENSOR

SM4000/SM1000 Series

## Applications Circuit for SOIC-10 Package

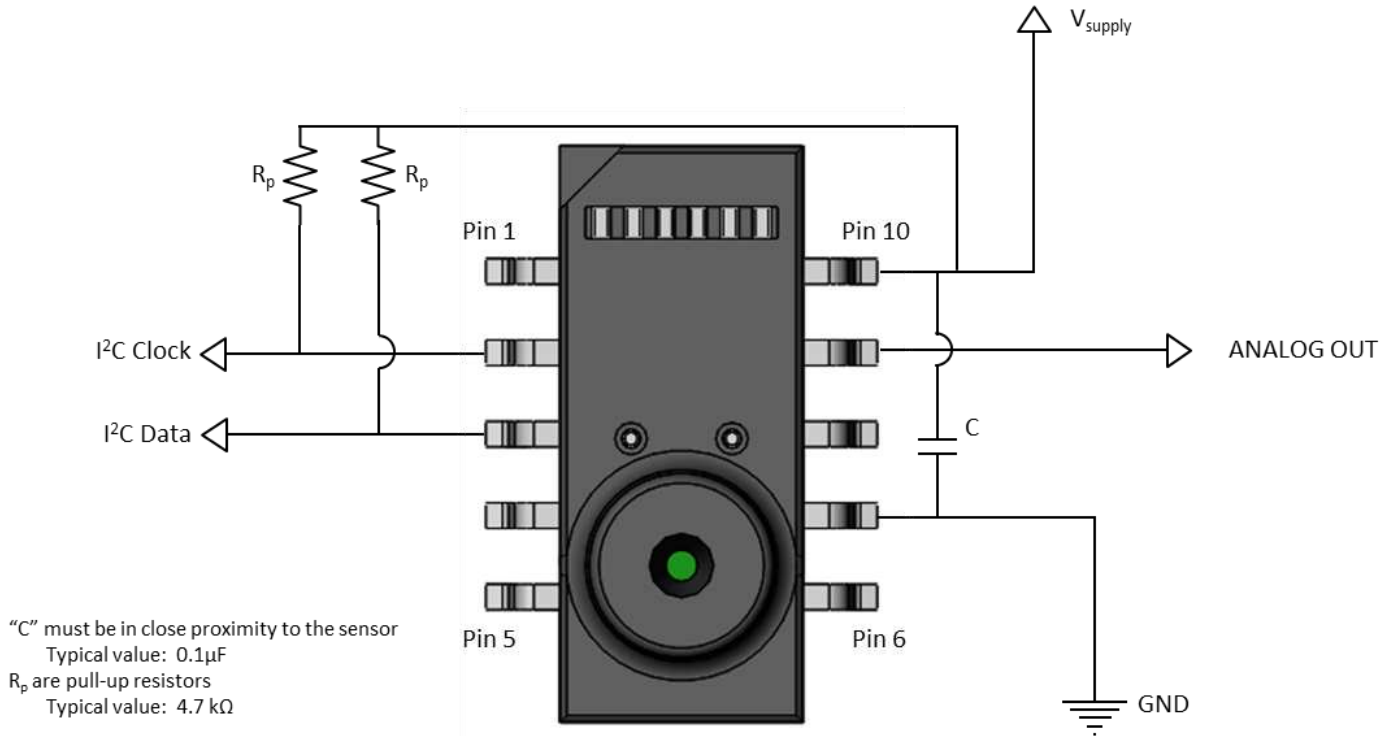

Pin No	Pin Function (XX91)	Pin Function (XX31)
1	NC (No Connect)	NC (No Connect)
2	SCL	SCL
3	SDA	SDA
4	NC	NC
5	NC	NC
6	NC	NC
7	GND	GND
8	NC	NC
9	VOUT (Analog Output)	NC
10	Power	Power

**Notes:**

- Do not connect to NC pins

## MEDIUM PRESSURE DIGITAL AND ANALOG SENSOR

SM4000/SM1000 Series

### 9. Ordering Information (Standard Configurations)

Part Number	Pressure Range	Output Type	Package Configuration	Voltage	Shipping <sup>(a)</sup>
SM4391-BCE-S-005-000	-5 to +5 PSI	Digital & Analog	SOIC-16 Dual Vertical	3.3 V	Sticks (45 parts/stick)
SM4291-BCE-S-005-000	0 to +5 PSI	Digital & Analog			
SM4391-BCE-S-350-000	-350 to +350 mmHg	Digital & Analog			
SM4291-HGE-S-350-000	0 to +350 mmHg	Digital & Analog	SOIC-10 Single Vertical		
SM1391-BCE-S-015-000	-15 to +15 PSI	Digital & Analog	SOIC-16 Dual Vertical		
SM1291-BCE-S-015-000	0 to +15 PSI	Digital & Analog			
SM1291-HGE-S-015-001	0 to +15 PSI	Digital & Analog	SOIC-10 Single Vertical		
SM1291-HGE-S-030-000	0 to +30 PSI	Digital & Analog			

**Notes:**

- a) All parts also available in shipping configuration Tape & Reel (SOIC-16 Dual Horizontal 500 parts/reel; SOIC-16 Dual Vertical 350 parts/reel), see section 10. Part Numbering Key for ordering information

# MEDIUM PRESSURE DIGITAL AND ANALOG SENSOR

SM4000/SM1000 Series

## 10. Part Numbering Key

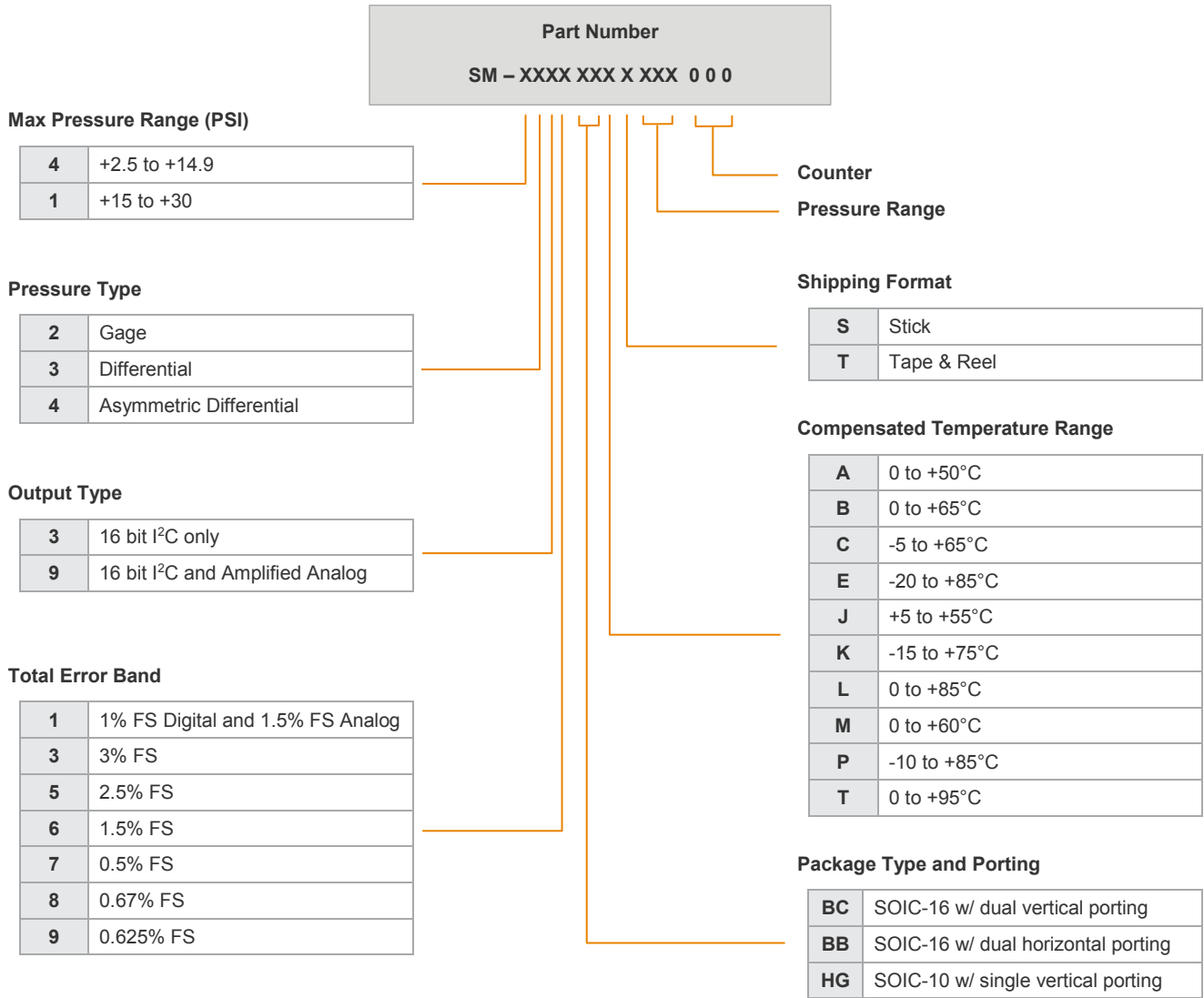

## MEDIUM PRESSURE DIGITAL AND ANALOG SENSOR

SM4000/SM1000 Series

### 11. I<sup>2</sup>C Communication protocol

#### 11.1 I<sup>2</sup>C Electrical Table

Description	Condition	Symbol	Min	Typ	Max	Units
SDA output low voltage	$I_{SDA} = 3 \text{ mA}$	$V_{SDA,OL}$	0		0.4	V
Low-to-High transition threshold	pins SA0, SCL	$V_{SDA,LH}$	0.5	0.6	0.7	*VDD
High-to-Low transition threshold	pins SA0, SCL	$V_{SDA,HL}$	0.3	0.4	0.5	*VDD
I <sup>2</sup> C clock frequency		$f_{SCL}$	0		400	kHz
Bus free time between a START and STOP condition <sup>*)</sup>		$t_{BUSF}$	1300			ns
Clock low time <sup>*)</sup>		$t_{LO}$	1300			ns
Clock high time <sup>*)</sup>		$t_{HI}$	600			ns
START condition hold time <sup>*)</sup>		$t_{SH}$	100			ns
Data setup time <sup>*)</sup>		$t_{SU}$	100			ns
Data hold time <sup>*)</sup>		$t_H$	0			ns
Setup time for repeated START condition <sup>*)</sup>		$t_{RSH}$	600			ns
Setup time for STOP condition <sup>*)</sup>		$t_{PSU}$	600			ns
Rise time of SDA and SCL signals <sup>*)</sup>		$t_R$			300	ns
Fall time of SDA and SCL signals <sup>*)</sup>		$t_F$			300	ns

<sup>\*)</sup> Not tested in production

#### 11.2 I<sup>2</sup>C Interface

The sensor features an I<sup>2</sup>C slave interface. This interface provides direct access to registers of the memory of the pressure sensor. An external I<sup>2</sup>C master (e.g. a microcontroller) can read from and write to memory addresses (registers) of the device using the following commands:

- **Random write:** Sets a memory address and writes data to consecutive memory addresses of the device starting at the set memory address.
- **Random read:** Sets a memory address and reads data from consecutive memory addresses of the device starting at the set memory address.
- **Read last:** Reads data from the device starting at the last memory address set by the master. This facilitates repeated reading of the same memory addresses without transmitting a memory address first.

All reads/writes must start at word aligned addresses (i.e. LSB of memory address equals 0) and read/write an even number of bytes.

I<sup>2</sup>C Interface Timing Diagram:

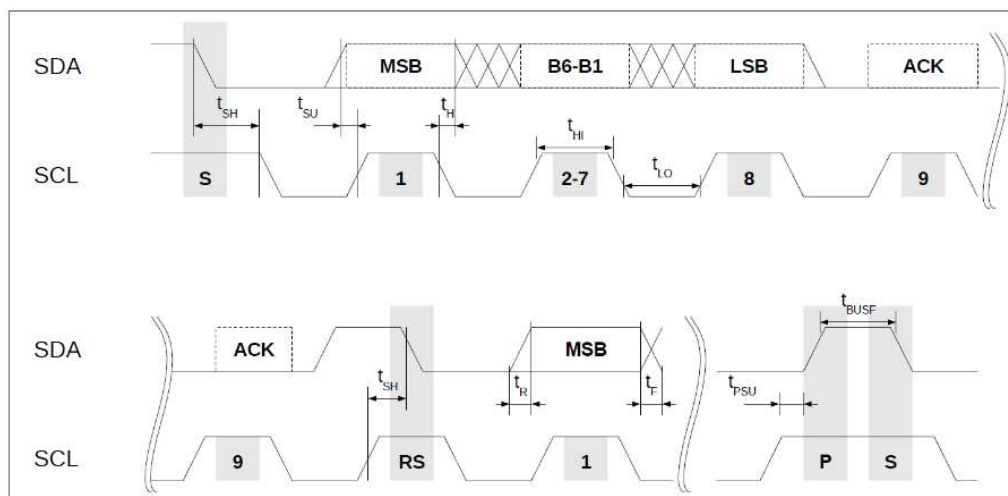

# MEDIUM PRESSURE DIGITAL AND ANALOG SENSOR

SM4000/SM1000 Series

## 11.3 I<sup>2</sup>C Command Format

The sensor uses a standard 7-bit I<sup>2</sup>C slave address field. The LSB of the slave address specifies the frame type used to perform read and write operations.

For LSB = 0 the protocol is compatible to standard I<sup>2</sup>C EEPROMs, for LSB = 1 the protocol is extended by a CRC protection. Thus, each device occupies two I<sup>2</sup>C addresses: even addresses are for standard EEPROM compatible protocols and odd addresses are for CRC protected protocols. Unprotected and CRC protected frames can be interleaved.

The two different frame types - standard EEPROM (without CRC) or CRC protected - are shown in the next two figures.

### I<sup>2</sup>C Read / Write Commands - Standard EEPROM compatible protocol

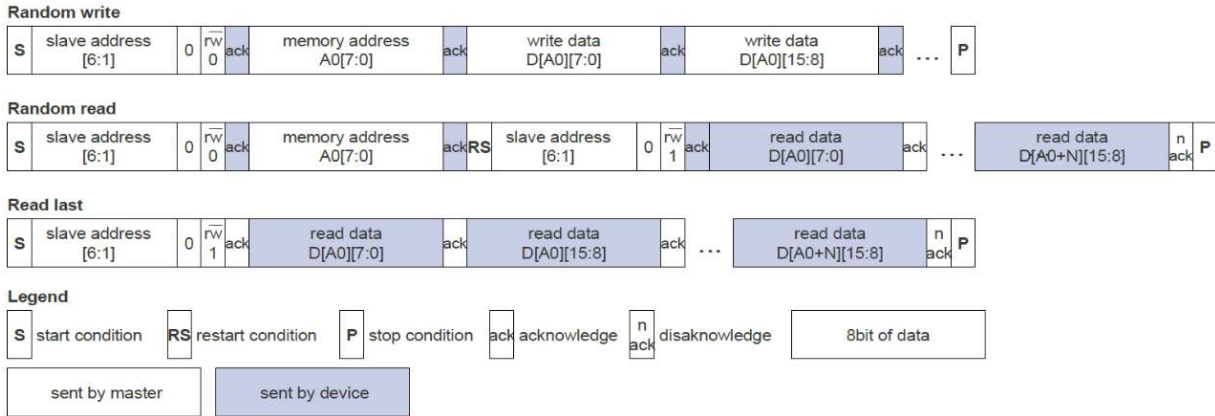

### I<sup>2</sup>C Read / Write Commands - CRC protected protocol

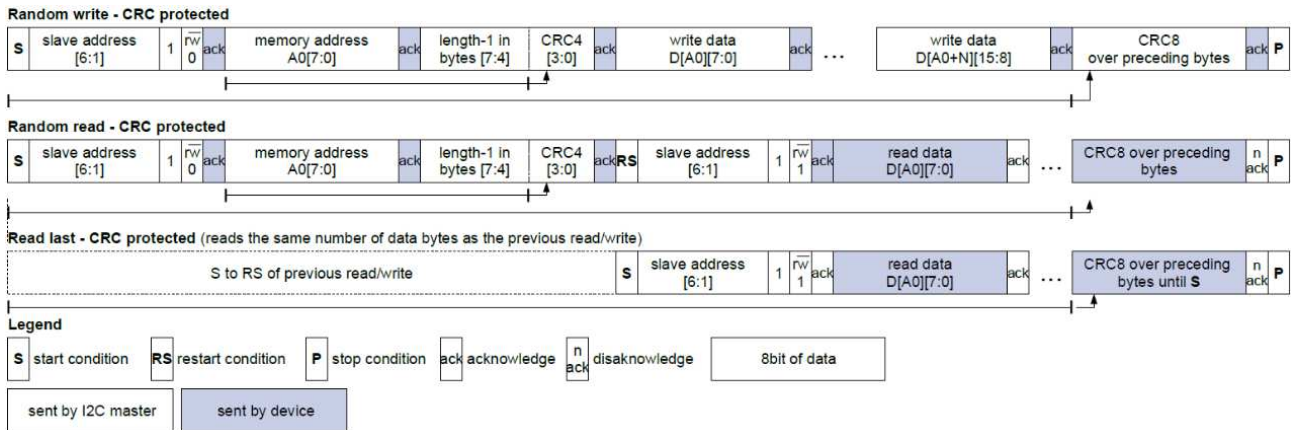

The memory address field sets the byte address of the first memory location to be read from or written to. Only 16-bit-word aligned reads/writes are supported, i.e. the LSB of memory address has to be zero always. The read/write data is transferred MSB first, low byte before high byte.

The length field (bits[7:4]) required for CRC protected frames specifies the number of data bytes to be transferred decremented by one, i.e. a value of 0001b corresponds to two bytes. All frames must transfer an even number of bytes. The maximum length for CRC protected read/write frames is 16/4 bytes. For unprotected frames the length is unlimited.

The CRC4 and CRC8 for redundancy check are computed in the same bit and byte order as the transmission over the bus. The polynomials employed are:

- CRC4: polynomial 0x03; initialization value: 0x0F
- CRC8: polynomial 0xD5; initialization value: 0xFF

If a CRC errors occurs, then the event bit com\_crc\_error in the STATUS register will be set.

## MEDIUM PRESSURE DIGITAL AND ANALOG SENSOR

SM4000/SM1000 Series

### 11.4 I<sup>2</sup>C Command Examples

For all examples below the 7-bit device slave address used is 0x6C for unprotected commands, and 0x6D for CRC protected commands, respectively.

The command sequence following describes an unprotected Read command (without CRC) of 3 subsequent 16-bit words starting at memory address 0x2E to read the corrected IC temperature, corrected pressure signal, and (synchronized) status bits of the sensor.

Byte #	0	1	2	3	4	5	6	7	8
SBM (sent by master)	0xD8	0x2E	0xD9						
SBM comment	slave address 6C + LSB = 0 for Write	memory address	slave address 6C + LSB = 1 for Read						
SBS (sent by sensor)				0xF2	0x7D	0xEA	0x82	0x1E	0x00
SBS comment				DSP_T (Lo-Byte) ad. 0x2E	DSP_T (Hi-Byte)	DSP_S (Lo-Byte) ad. 0x30	DSP_S (Hi-Byte)	sync'ed Status (b7 - b0) ad. 0x32	sync'ed Status (b15 - b8)

Random Read – protected by CRC:

The following sequence describes the CRC protected version of reading 3 subsequent 16-bit words starting at memory address 0x2E to read the corrected IC temperature, corrected pressure signal, and (synchronized) status bits of the sensor.

Byte #	0	1	2	3	4	5	6	7	8	9	10
SBM (sent by master)	0xDA	0x2E	0xDB								
SBM comment	slave address 6D + LSB = 0 for Write	memory address	3: length = 4Byte B: CRC4	slave address 6D + LSB = 1 for Read							
SBS (sent by sensor)					0xF2	0x7D	0xEA	0x82	0x1E	0x00	0x65
SBS comment					DSP_T (Lo-Byte) ad. 0x2E	DSP_T (Hi-Byte)		DSP_S (Hi-Byte)	sync'ed Status (b7 - b0) ad. 0x32	sync'ed Status (b15 - b8)	CRC8 (calc'd)

Random Write:

The following sequence writes one 16-bit word to address 0x22 (without CRC protection). This will copy 0x6C32 into the command register CMD to move the component to Sleep Mode.

Byte #	0	1	2	3
SBM (sent by master)	0xD8	0x22	0x32	0x6C
SBM comment	slave address 6C + LSB = 0 for Write	memory address	Lo-Byte written to CMD[7:0]	Hi-Byte written to CMD[15:8]
SBS (sent by sensor)				
SBS comment				

## MEDIUM PRESSURE DIGITAL AND ANALOG SENSOR

SM4000/SM1000 Series

### 11.5 Register Descriptions

Register Read or Write are performed via the digital communication interface. After power-up of the IC all registers except STATUS and CMD are write protected.

Command register:

0x22	CMD			
bits	name	default	rw	description
15:0	cmd	0	w	Writing to this register controls the state of the device.
				0x6C32: SLEEP Mode Initiate the power state SLEEP, powering down the ASIC
				0xB169: RESET Performs a reset. After reset the power-up sequence will be executed, i.e. the registers are loaded with data from the configuration memory, also a CRC check is performed.

Temperature register:

0x2E	DSP_T			
bits	name	default	rw	description
15:0	dsp_t		r	Corrected temperature measurement value of the sensor. Whenever this register is updated with a new measurement the STATUS.dsp_t_up event bit is set.

Pressure register:

0x30	DSP_S			
bits	name	default	rw	description
15:0	dsp_s		r	Corrected pressure measurement value of the sensor. Whenever this register is updated with a new measurement the STATUS.dsp_s_up event bit is set.

The registers DSP\_T and DSP\_S contain invalid data after power-up until the first temperature and pressure values have been measured by the device and transferred to these registers. In case a NVM CRC error occurred, the DSP\_T and DSP\_S registers would never be updated. Thus, after power up it is necessary to wait until the STATUS.dsp\_s\_up and dsp\_t\_up bits have been set at least once before using the temperature or pressure data. It is not sufficient to wait just for a fixed time delay.

## MEDIUM PRESSURE DIGITAL AND ANALOG SENSOR

SM4000/SM1000 Series

Status register - synchronized:

0x32	STATUS_SYNC					
bits	name	default	rw	type	description	
0	idle	0	rw	status	STATUS.idle	
1	- reserved -	0	rw	event	reserved	
2	- reserved -	0	rw	event	reserved	
3	dsp_s_up	0	rw	event	when DSP_S is read STATUS.dsp_s_up is copied here	
4	dsp_t_up	0	rw	event	when DSP_T is read STATUS.dsp_t_up is copied here	
5	- reserved -	0	rw	status	reserved	
6	- reserved -	0	rw	status	reserved	
7	bs_fail	0	rw	event	STATUS.bs_fail	
8	bc_fail	0	rw	event	STATUS.bc_fail	
9	- reserved -	0	rw	event	reserved	
10	dsp_sat	0	rw	status	STATUS.dsp_sat	
11	com_crc_error	0	rw	event	STATUS.com_crc_error	
12	- reserved -	0	rw	status	reserved	
13	- reserved -	0	rw	status	reserved	
14	dsp_s_missed	0	rw	event	STATUS.dsp_s_missed	
15	dsp_t_missed	0	rw	event	STATUS.dsp_t_missed	

The bits STATUS\_SYNC[15:5,0] are identical to the bits STATUS[15:5,0].

The bits STATUS\_SYNC[4:3] are copied from the STATUS register when the corresponding DSP registers are read. First reading the DSP registers and then STATUS\_SYNC confirms that both values are consistent to each other.

The synchronized status STATUS\_SYNC register can be used to continuously poll the pressure, temperature and status of the device with a single read command by reading three 16 bit words starting at address 0x2E. By evaluating STATUS\_SYNC.dsp\_t\_up and STATUS\_SYNC.dsp\_s\_up it can be determined if the values in DSP\_T and DSP\_S acquired during the same read contain recently updated temperature or pressure values.

Status register:

0x36	STATUS					
bits	name	default	rw	type <sup>1</sup>	description	
0	idle	0	rw	status	0: chip in busy state 1: chip in idle state	
1	- reserved -	0	rw	event	reserved	
2	- reserved -	0	rw	event	reserved	
3	dsp_s_up	0	rw	event	1: DSP_S register has been updated. Cleared when DSP_S is read	
4	dsp_t_up	0	rw	event	1: DSP_T register has been updated. Cleared when DSP_T is read.	
5	- reserved -	0	rw	status	reserved	
6	- reserved -	0	rw	status	reserved	
7	bs_fail	0	rw	event	1: bridge supply failure occurred	
8	bc_fail	0	rw	event	1: sensor bridge check failure occurred	
9	- reserved -	0	rw	event	reserved	
10	dsp_sat	0	rw	status	1:a DSP computataion leading to current DSP_T or DSP_S values was saturated to prevent overflow	
11	com_crc_error	0	rw	event	1:communication CRC error	
12	- reserved -	0	rw	status	reserved	
13	- reserved -	0	rw	status	reserved	
14	dsp_s_missed	0	rw	event	1:dsp_s_up was 1 when DSP_S updated	
15	dsp_t_missed	0	rw	event	1:dsp_t_up was 1 when DSP_T updated	

- "Event" type flags remain set until cleared by writing '1' to the respective bit position in STATUS register (not STATUS\_SYNC). Writing 0xFFFF to the STATUS register will clear all event bits.
- "Status" type flag represents a condition of a hardware module of the IC and persists until the condition has disappeared.



# MEDIUM PRESSURE DIGITAL AND ANALOG SENSOR

SM4000/SM1000 Series

Serial Number register 0:

0x50	SER0			
bits	name	default	rw	description
15:0	ser0		r	Serial number of the IC, Lo-Word

Serial Number register 1:

0x52	SER1			
bits	name	default	rw	description
15:0	ser1		r	Serial number of the IC, Hi-Word

## 12. Qualification Standards

REACH Compliant  
RoHS Compliant  
PFOS/PFOA Compliant  
For qualification specifications



### GLOBAL

Tel +1 408 577 0100  
[customercare.mlpt@te.com](mailto:customercare.mlpt@te.com)

## te.com/sensors

TE Connectivity, TE, TE Connectivity (logo) and Every Connection Counts are trademarks. All other logos, products and/or company names referred to herein might be trademarks of their respective owners

The information given herein, including drawings, illustrations and schematics which are intended for illustration purposes only, is believed to be reliable. However, TE Connectivity makes no warranties as to its accuracy or completeness and disclaims any liability in connection with its use. TE Connectivity's obligations shall only be as set forth in TE Connectivity's Standard Terms and Conditions of Sale for this product and in no case will TE Connectivity be liable for any incidental, indirect or consequential damages arising out of the sale, resale, use or misuse of the product. Users of TE Connectivity products should make their own evaluation to determine the suitability of each such product for the specific application.

© 2020 TE Connectivity Corporation. All Rights Reserved.

Version 04/2020

