

ISL68127

Digital Dual Output, 7-Phase Configurable, PWM Controller with PMBus

FN8748
Rev.2.00
Jul 12, 2019

The [ISL68127](#) is a digital dual output, flexible multiphase ($X+Y \leq 7$) PWM controller supporting the latest PMBus V1.3 specifications. The ISL68127 can be configured to support any desired phase assignments up to a maximum of seven phases across the two outputs ($X+Y$). For example, 6+1, 5+2, 4+2, 3+3, 3+2, or even a single output operation as a 7+0 configuration are supported. The ISL68127 uses the Renesas proprietary linear synthetic digital current modulation scheme to achieve the industry's best combination of transient response and ease of tuning while addressing the challenges of modern multiphase designs.

You can configure the device and monitor telemetry using the intuitive Renesas PowerNavigator GUI. The ISL68127 device supports on-chip nonvolatile memory to store various configuration settings that are user-selectable through pin-strap, giving system designers increased power density to configure and deploy multiple configurations. The automatic phase add/drop feature allows maximum efficiency across all load ranges. Thresholds for automatic phase add/drop are user-programmable using PowerNavigator.

The ISL68127 supports a comprehensive fault management system to enable the design of highly reliable systems. From a multitiered overcurrent protection scheme to the configurable power-good and output overvoltage/undervoltage fault thresholds and temperature monitoring, almost any need is accommodated.

With minimal external components, easy configuration, robust fault management, and highly accurate regulation capability, implementing a high-performance, multiphase regulator has never been easier.

Applications

- Networking equipment
- Telecom and datacom equipment
- Server and storage equipment
- Point-of-load power supply (Memory, DSP, ASIC, FPGA)

Features

- Advanced linear digital modulation scheme
 - Zero latency synthetic current control for excellent HF current balance
 - Dual edge modulation for fastest transient response
- Auto phase add/drop for excellent load vs efficiency profile
- PMBus V1.3 support
 - Telemetry: V_{IN} , V_{OUT} , I_{OUT} , power IN/OUT, temperature, and various fault status registers
 - Up to 1MHz bus interface
- Flexible phase configuration
 - 7+0, 6+1, 5+2, and 4+3 phase operation
 - Operation using fewer than seven phases between two outputs is also supported
- Diode braking for overshoot reduction
- Differential remote voltage sensing supports $\pm 0.5\%$ closed loop system accuracy over load, line, and temperature
- Highly accurate current sensing for excellent load line regulation and accurate OCP
 - Supports the ISL99227 60A smart power stage
 - Supports DCR sense with integrated temperature compensation
- Comprehensive fault management enables high reliability systems
 - Pulse-by-pulse phase current limiting
 - Total output current protection
 - Output and input OV/UV
 - Open voltage sense detect
 - Black box recording capability for faults
- Intuitive configuration using [PowerNavigator](#)
 - NVM to store up to eight configurations
- Pb-free (RoHS compliant)

Related Literature

For a full list of related documents, visit our web page:

- [ISL68127](#) product page

Table of Contents

Ordering Information	3
Pin Configuration	3
Functional Pin Descriptions	4
Driver, DrMOS, and Smart Power Stage Recommendations	4
Internal Block Diagram	5
Typical Application: 6+1 Configuration with ISL99227 SPS	6
Typical Application: 4+3 Configuration with ISL99227 SPS	7
Typical Application: 5+2 Configuration with DCR Sensing	8
Typical Application: Phase Doubler 14-Phase VR with ISL6617A+SPS	9
Absolute Maximum Ratings	10
Thermal Information	10
Recommended Operating Conditions	10
Electrical Specifications	10
Typical Performance Curves	12
Functional Description	12
Overview	12
PWM Modulation Scheme	12
PMBus Address Selection	12
Phase Configuration	12
Automatic Phase Add and Drop	13
Output Voltage Configuration	13
Switching Frequency	13
Current Sensing	13
Temperature Sensing	15
Temperature Compensation	15
Lossless Input Current and Power Sensing	16
Voltage Regulation	16
Current Feedback	16
Power-On Reset (POR)	16
Soft-Start Delay and Ramp Times	16
Stored Configuration Selection	16
Fault Monitoring and Protection	17
Power-Good Signals	17
Output Voltage Protection	17
Output Current Protection	17
Smart Power Stage OC Fault Detect	18
Thermal Monitoring and Protection	18
Layout and Design Considerations	19
PMBus Operation	20
PMBus Protocol	21
PMBus Command Summary	22
PMBus Use Guidelines	23
PMBus Data Formats	23
PMBus Command Detail	24
Revision History	46
Package Outline Drawing	47

Ordering Information

PART NUMBER (Notes 2, 3)	PART MARKING	TEMP. RANGE (°C)	TAPE AND REEL (UNITS) (Note 1)	PACKAGE (RoHS COMPLIANT)	PKG. DWG. #
ISL68127IRAZ	ISL68127 IRZ	-40 to +85	-	48 Ld 6x6 QFN	L48.6x6B
ISL68127IRAZ-T	ISL68127 IRZ	-40 to +85	4k	48 Ld 6x6 QFN	L48.6x6B
ISL68127IRAZ-T7A	ISL68127 IRZ	-40 to +85	250	48 Ld 6x6 QFN	L48.6x6B

NOTES:

1. Refer to [TB347](#) for details about reel specifications.
2. These Pb-free plastic packaged products employ special Pb-free material sets, molding compounds/die attach materials and 100% matte tin plate plus anneal (e3 termination finish, which is RoHS compliant and compatible with both SnPb and Pb-free soldering operations). Pb-free products are MSL classified at Pb-free peak reflow temperatures that meet or exceed the Pb-free requirements of IPC/JEDEC J STD-020.
3. For Moisture Sensitivity Level (MSL), see the [ISL68127](#) device page. For more information about MSL, see [TB363](#).

TABLE 1. KEY DIFFERENCES BETWEEN FAMILY OF PARTS

PART NUMBER	PHASE CONFIGURATION OUTPUT X/OUTPUT Y	SPECIFICATION SUPPORTED	PACKAGE
ISL68127	X+Y ≤ 7	PMBus	QFN 48 Ld, 6x6mm
ISL68137	X+Y ≤ 7	PMBus/AVSBus	QFN 48 Ld, 6x6mm
ISL68134	X+Y ≤ 4	PMBus/AVSBus	TQFN 40 Ld, 5x5mm
ISL68124	X+Y ≤ 4	PMBus	TQFN 40 Ld, 5x5mm

Pin Configuration

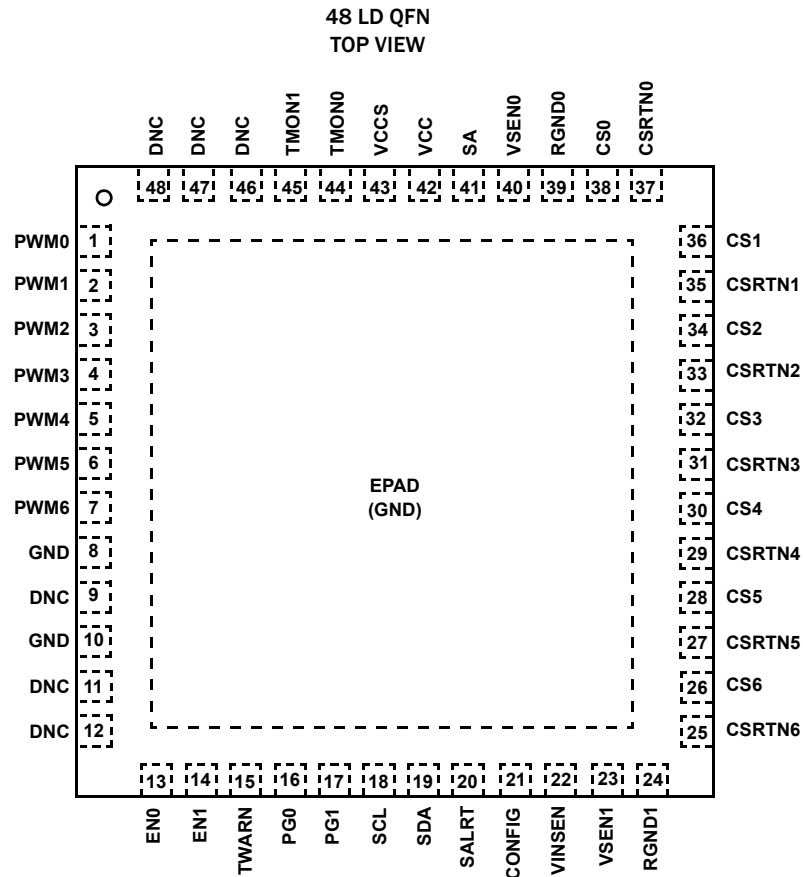

Functional Pin Descriptions

Refer to [Table 4 on page 19](#) for design layout considerations.

PIN NUMBER	PIN NAME	DESCRIPTION
1, 2, 3, 4, 5, 6, 7	PWM[6:0]	Pulse-width modulation (PWM) outputs. Connect these pins to the PWM input pins of 3.3V logic-compatible Renesas smart power stages, driver IC(s), or power stages.
8, 10	GND	Ground pins. Connect directly to a system GND plane.
9, 11, 12, 46, 47, 48	DNC	Do not connect any signals to these pins.
13	EN0	Input pin used as the Output 0 enable control. Active high. Connect to ground if not used.
14	EN1	Input pin used as the Output 1 enable control. Active high. Connect to ground if not used.
15	TWARN	Thermal warning flag. This open-drain output is pulled low without disabling the regulators if the TMON pins sense an over-temperature event. Maximum pull-up voltage is V_{CC} .
16	PG0	Open-drain, power-good indicators for Output 0. Maximum pull-up voltage is V_{CC} .
17	PG1	Open-drain, power-good indicators for Output 1. Maximum pull-up voltage is V_{CC} .
18	SCL	Serial clock signal pin for the SMBus interface. Maximum pull-up voltage is V_{CC} .
19	SDA	Serial data signal pin for the SMBus interface. Maximum pull-up voltage is V_{CC} .
20	SALRT	Serial alert signal pin for the SMBus interface. Maximum pull-up voltage is V_{CC} .
21	CONFIG	Configuration ID selection pin. See Table 3 on page 16 for more details.
22	VINSEN	Input voltage sense pin. Connect to VIN through a resistor divider (typically 40.2k/10k) with a 10nF decoupling capacitor.
23	VSEN1	Positive differential voltage sense input for Output 1. Connect to a positive remote sensing point. Connect to ground if not used.
24	RGND1	Negative differential voltage sense input for Output 1. Connect to a negative remote sensing point. Connect to ground if not used.
25, 27, 29, 31, 33, 35, 37	CSRTN[6:0]	The CS and CSRTN pins are current sense inputs to individual phase differential amplifiers. Ground the current sense input of unused phases. The ISL68127 supports smart power stage, DCR, and resistor sensing. Connection details depend on the current sense method chosen.
26, 28, 30, 32, 34, 36, 38	CS[6:0]	
39	RGND0	Negative differential voltage sense input for Output 0. Connect to a negative remote sensing point. Connect to ground if not used.
40	VSEN0	Positive differential voltage sense input for for Output 0. Connect to a positive remote sensing point. Connect to ground if not used.
41	SA	PMBus address selection pin. See Table 2 on page 12 for more details.
42	VCC	Chip primary bias input. Connect this pin directly to a +3.3V supply with a high quality MLCC bypass capacitor.
43	VCCS	Internally generated 1.2V LDO logic supply from VCC. Decouple with a 4.7 μ F or greater MLCC (X5R or better).
44	TMON0	Input pin for external temperature measurement at Output 0. Supports diode-based temperature sensing and smart power stage sensing. Refer to "Temperature Compensation" on page 15 for more information.
45	TMON1	Input pin for external temperature measurement at Output 1. Supports diode-based temperature sensing and smart power stage sensing. Refer to "Temperature Compensation" on page 15 for more information.
EPAD	GND	The package pad serves as the GND return for all chip functions. Connect directly to the system GND plane with multiple thermal vias.

Driver, DrMOS, and Smart Power Stage Recommendations

PART NUMBER	QUIESCENT CURRENT (mA)	GATE DRIVE VOLTAGE (V)	NUMBER OF DRIVERS	COMMENTS
ISL99227	4.85	5	Single	60A, 5x5 smart power stage
ISL99140	0.19	5	Single	40A, 6x6 DrMOS
ISL6596	0.19	5	Single	Connect ISL6596 VCTRL to 3.3V
ISL6617A	5	N/A	N/A	Phase Doubler with 5V PWM output to be compatible with 60A DrMOS or with 60A smart power stage. Supports up to a 14-phase design.

Internal Block Diagram

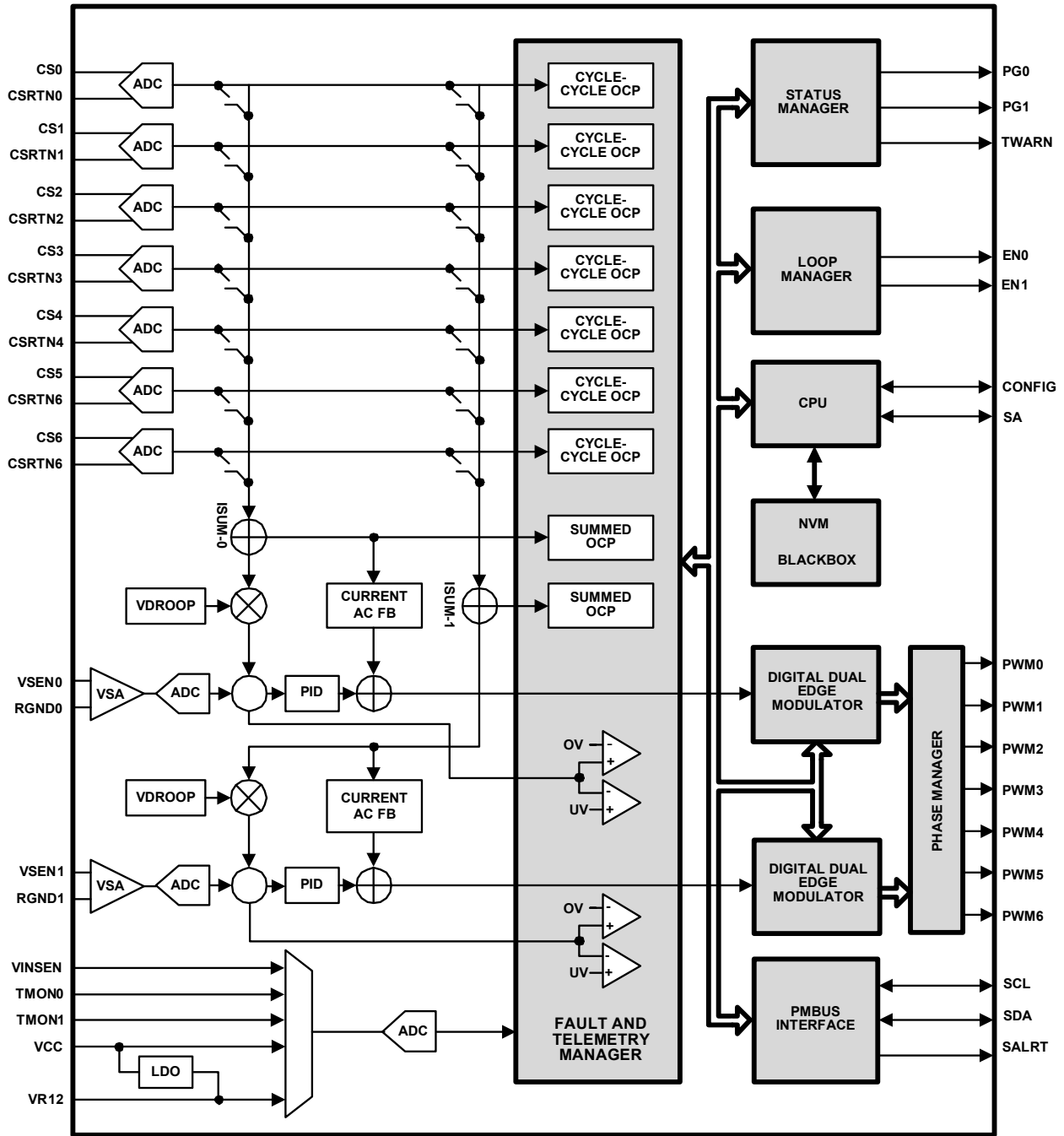

FIGURE 1. INTERNAL BLOCK DIAGRAM

Typical Application: 6+1 Configuration with ISL99227 SPS

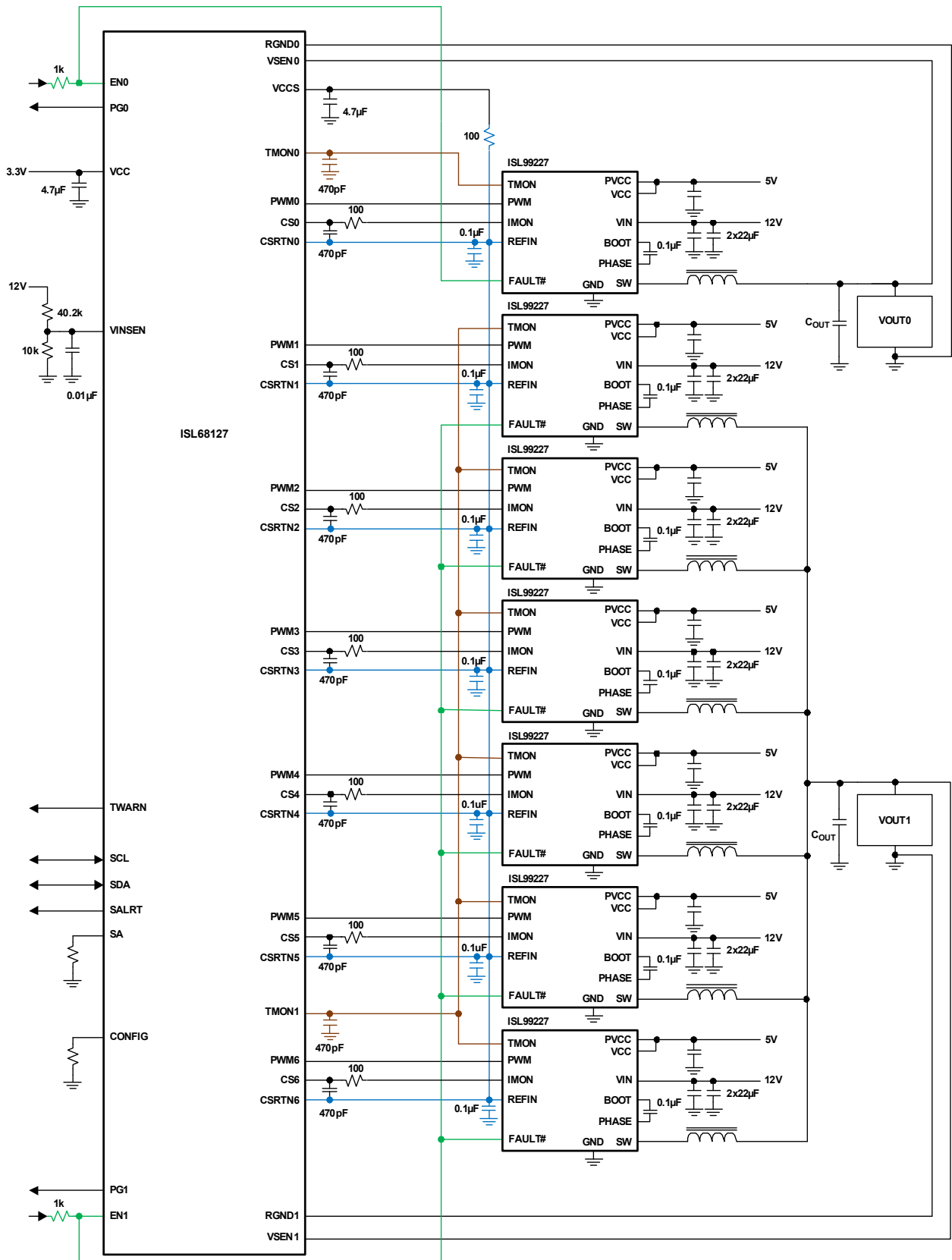

FIGURE 2. TYPICAL APPLICATION: 6+1 CONFIGURATION WITH ISL99227 SPS

Typical Application: 4+3 Configuration with ISL99227 SPS

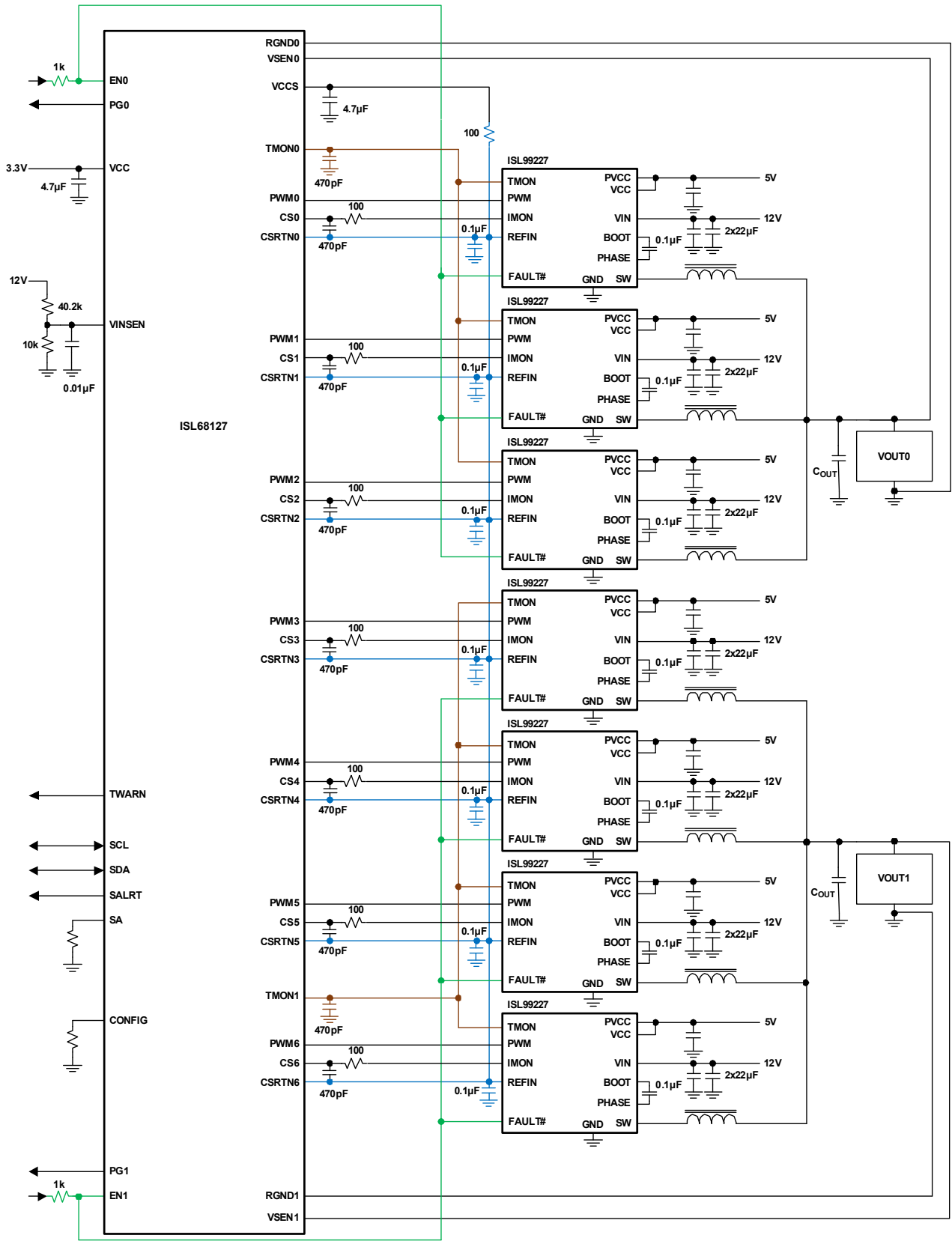

FIGURE 3. TYPICAL APPLICATION: 4+3 CONFIGURATION WITH ISL99227 SPS

Typical Application: 5+2 Configuration with DCR Sensing

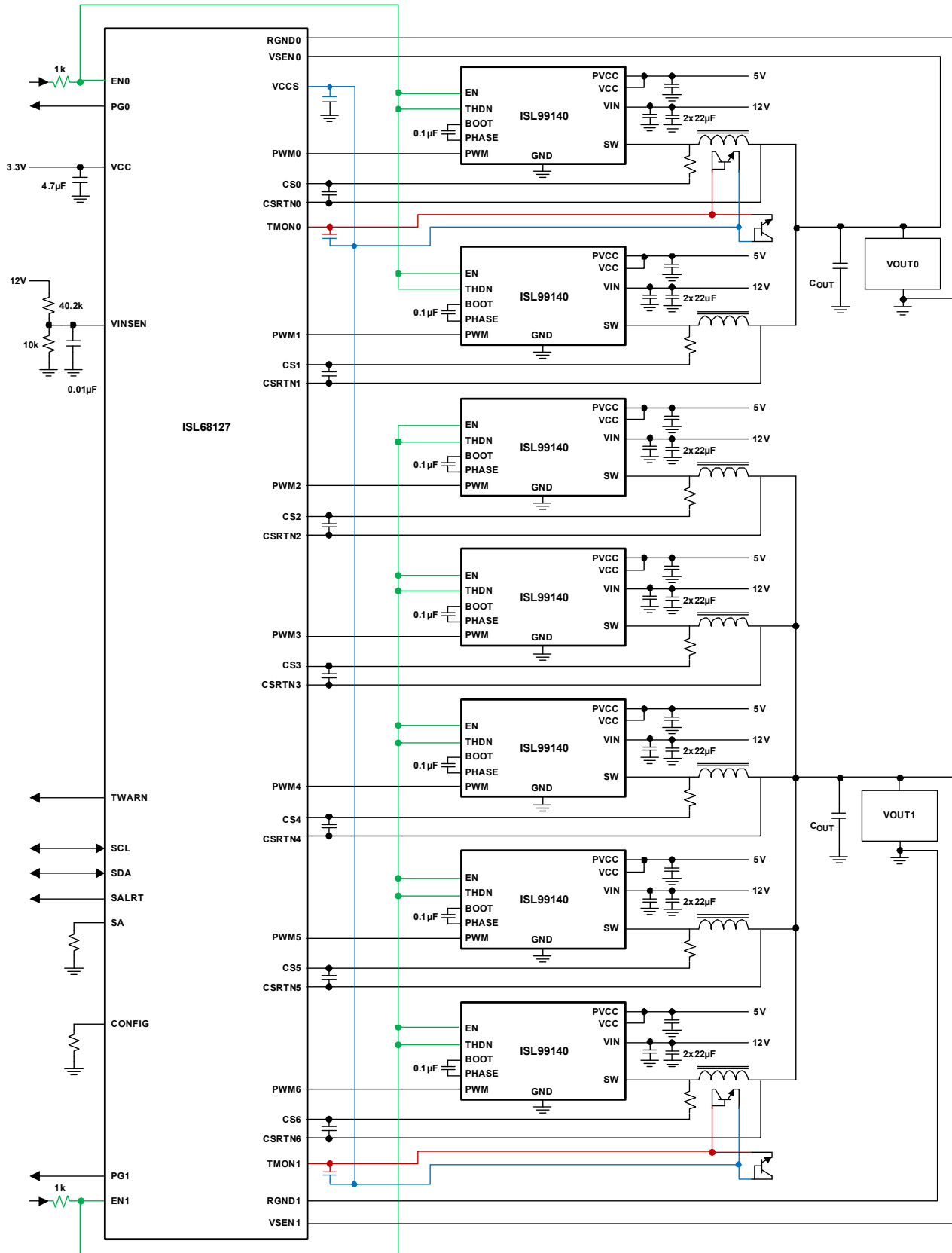

FIGURE 4. TYPICAL APPLICATION: 5+2 CONFIGURATION WITH DCR SENSING

Typical Application: Phase Doubler 14-Phase VR with ISL6617A+SPS

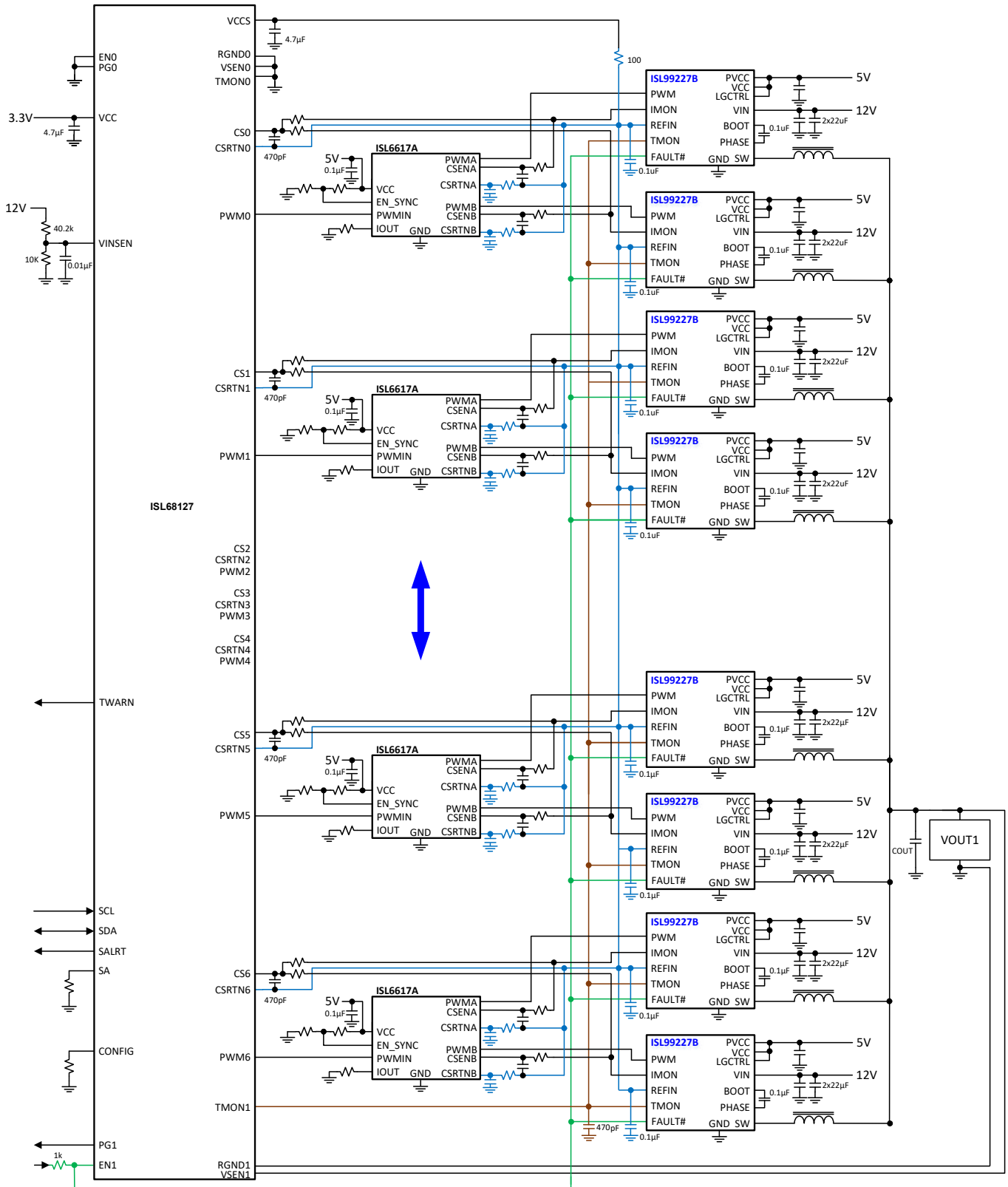

FIGURE 5. PHASE DOUBLER 14-PHASE VR WITH ISL6617A+SMART POWER STAGE

Absolute Maximum Ratings

VCC	+4.3V
VCCS	+1.6V
All Other Pins	(GND - 0.3V) to VCC + 0.3V
ESD Rating:	
Human Body Model (Tested per JS-001-2014)	2kV
Charged Device Model (Tested per JS-001-2014)	1kV
Latch-Up (Tested per JESD-78D; Class 2, Level A)	100mA

Thermal Information

Thermal Resistance (Notes 4, 5)	θ_{JA} (°C/W)	θ_{JC} (°C/W)
48 Ld 6x6 QFN Package	27	1
Maximum Junction Temperature	+150°C	
Maximum Storage Temperature Range	-65°C to +150°C	
Pb-Free Reflow Profile	see TB493	

Recommended Operating Conditions

Supply Voltage, V _{CC}	+3.3V ±5%
Ambient Temperature	-40°C to +85°C
Output Voltage	0V to 3.05V

CAUTION: Do not operate at or near the maximum ratings listed for extended periods of time. Exposure to such conditions can adversely impact product reliability and result in failures not covered by warranty.

NOTES:

- θ_{JA} is measured in free air with the component mounted on a high-effective thermal conductivity test board with "direct attach" features. See [TB379](#).
- For θ_{JC} , the "case temp" location is the center of the exposed metal pad on the package underside.

Electrical Specifications Recommended operating conditions, V_{CC} = 3.3V, unless otherwise specified. **Boldface limits apply across the operating temperature range -40°C to +85°C.**

PARAMETER	TEST CONDITIONS	MIN (Note 7)	TYP	MAX (Note 7)	UNIT
V_{CC} SUPPLY CURRENT					
Nominal Supply Current	V _{CC} = 3.3VDC; EN1/2 = V _{IH} ; f _{SW} = 400kHz		90.5		mA
Shutdown Supply Current	V _{CC} = 3.3VDC; EN1/2 = 0V, no switching		11.4		mA
VCCS LDO SUPPLY					
Output Voltage		1.20	1.25	1.30	V
Maximum Current Capability	Excluding internal load	50			mA
POWER-ON RESET AND INPUT VOLTAGE LOCKOUT					
V _{CC} Rising POR Threshold			2.7	2.9	V
V _{CC} Falling POR Threshold		1.0			V
Enable (EN0 and EN1) Input High Level		2.55			V
Enable (EN0 and EN1) Input Low Level				0.8	V
Enable (EN0 and EN1) Input LOW to HIGH Ramp Delay (TON_DELAY)		200			µs
POR to Initialization Complete Time			30	40	ms
OUTPUT VOLTAGE CHARACTERISTICS (Note 6)					
Output Voltage Adjustment Range		0.25		3.05	V
Output Voltage Set-Point Accuracy	Set-point 0.8V to 3.05V	-0.5		0.5	%
	Set-point 0.25V to <0.8V	-5		5	mV
VOLTAGE SENSE AMPLIFIER					
Open Sense Current	During open pin check of initialization only		22		µA
Input Impedance (VSEN - RGND)			200		kΩ
Maximum Common-Mode Input			V _{CC} - 0.2		V
Maximum Differential Input (VSEN - RGND)				3.05	V
CURRENT SENSE AND OVERCURRENT PROTECTION					
Maximum Common-Mode Input (SPS mode)	CSRTNx - GND		1.6		V
Maximum Common-Mode Input (DCR mode)	CSRTNx - GND		3.3		V
Current Sense Accuracy	ISEN to ADC accuracy	-2		2	%
Average Overcurrent Threshold Resolution			0.1		A
Cycle-by-Cycle Current Limiting Threshold Accuracy			0.1		A

Electrical Specifications Recommended operating conditions, $V_{CC} = 3.3V$, unless otherwise specified. **Boldface limits apply across the operating temperature range $-40^{\circ}C$ to $+85^{\circ}C$.** (Continued)

PARAMETER	TEST CONDITIONS	MIN (Note 7)	TYP	MAX (Note 7)	UNIT
DIGITAL DROOP					
Droop Resolution			0.01		mV/A
OSCILLATORS					
Accuracy of Switching Frequency Setting	When set to 500kHz	480	500	520	kHz
		-4		+4	%
Switching Frequency Range		200		1000	kHz
SOFT-START RATE AND VOLTAGE TRANSITION RATE					
Minimum Soft-Start Ramp Rate	Programmable minimum rate		20		μs
Maximum Soft-Start Ramp Rate	Programmable maximum rate		10		ms
Soft-Start Ramp Rate Accuracy		-4		4	%
Minimum Transition Rate	Programmable minimum rate		0.1		mV/ μs
Maximum Transition Rate	Programmable maximum rate		100		mV/ μs
Transition Rate Accuracy		-4		4	%
PWM OUTPUT					
PWMx Output High Level	$I_{OUT} = 4mA$	$V_{CC} - 0.4$			V
PWMx Output Low Level	$I_{OUT} = 4mA$			0.4	V
PWMx Output Tri-State I_{OL}	$V_{OH} = V_{CC}$			1	μA
PWMx Output Tri-State I_{OH}	$V_{OL} = 0V$	-1			μA
THERMAL MONITORING AND PROTECTION					
Temperature Sensor Range		-50		150	$^{\circ}C$
Temperature Sensor Accuracy	TMON to ADC accuracy	-4.5		4.5	%
TWARN Output Low Impedance		4	9	13	Ω
TWARN Hysteresis			3		$^{\circ}C$
POWER-GOOD AND PROTECTION MONITORS					
PG Output Low Voltage	$I_{OUT} = 8mA$ load			0.4	V
PG Leakage Current	With pull-up resistor externally connected to VCC		0.5	1	μA
Overvoltage Protection Threshold Resolution			1		mV
Undervoltage Protection Threshold Resolution			1		mV
Overvoltage Protection Threshold When Disabled			$V_{CC} - 0.2$		V
INPUT VOLTAGE SENSE					
Input Voltage Accuracy	VINSEN to ADC accuracy	-2.5		2.5	%
Input Voltage Protection Threshold Resolution			1		mV
SMBus/PMBus					
SALERT, SDA Output Low Level	$I_{OUT} = 4mA$			0.4	V
SCL, SDA Input High Level		1.55			V
SCL, SDA Input Low Level				0.8	V
SCL, SDA Input Hysteresis			2		mV
SCL Frequency Range		0.05		2	MHz

NOTES:

- These parts are designed and adjusted for accuracy with all errors in the voltage loop included.
- Compliance to datasheet limits is assured by one or more methods: production test, characterization, and/or design.

Typical Performance Curves

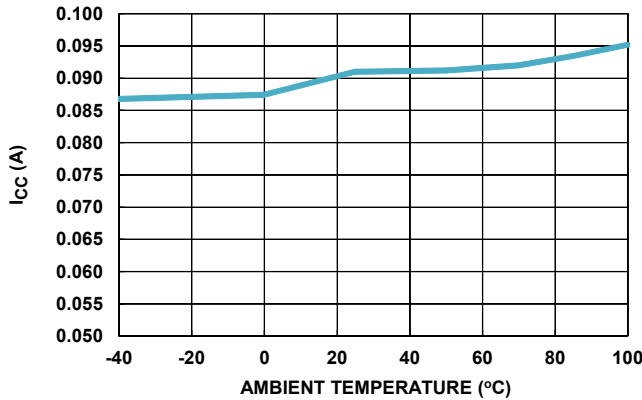

FIGURE 6. NOMINAL SUPPLY CURRENT vs TEMPERATURE

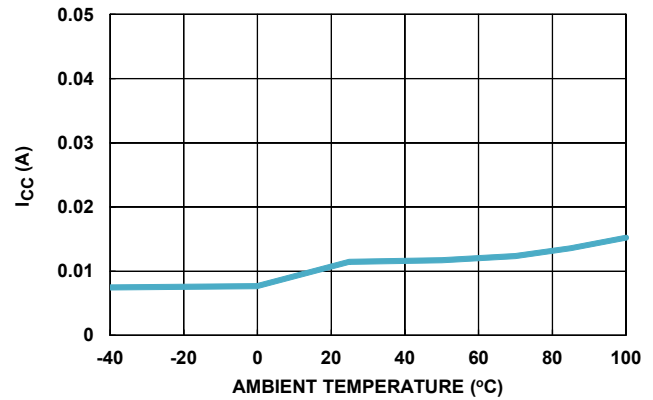

FIGURE 7. SHUTDOWN SUPPLY CURRENT vs TEMPERATURE

Functional Description

Overview

The ISL68127 is a digital dual output 7-phase PWM controller that can be programmed for a single output 7+0, dual output 6+1, 5+2, or 4+3 phase operation. Operation using fewer than seven phases between two outputs is also supported. Existing digital multiphase solutions use nonlinear analog comparator based schemes to bolster the inadequate transient response common to many digital multiphase solutions. The ISL68127 uses a linear voltage regulation scheme to address transient loads. As a result, it is much easier for users to configure and validate designs compared to nonlinear schemes. By combining a proprietary low noise and zero latency digital current sense scheme with cutting edge digital design techniques, Renesas can meet transient demands without resorting to nonlinear schemes. In addition, the ISL68127 can store up to eight user configurations in NVM and allows you to select the desired configuration through pin-strap (CONFIG). The result is a system that is easy to configure and deploy.

The ISL68127 includes performance enhancing features such as diode braking, automatic phase dropping, DCR/resistor/smart power stage current sense support, load line regulation, and multiple temperature sensing options.

To facilitate configuration development, the PowerNavigator GUI provides a step-by-step arrangement for setup and parametric adjustment. After setting a configuration, you can use PowerNavigator to monitor telemetry or use the PMBus interface based on the supported command set.

PWM Modulation Scheme

The ISL68127 uses the Renesas proprietary linear synthetic current modulation scheme to improve transient performance. This unique, constant frequency, dual-edge PWM modulation scheme moves both the PWM leading and trailing edges independently to give the best response to transient loads. Current balance is an inherent part of the regulation scheme. The modulation scheme is capable of overlapping pulses if the load profile requires it. The modulator can also add or remove pulses

from a given cycle in response to regulation demands while still managing maximum average frequency to safe levels. The operating frequency is constant for DC load conditions.

PMBus Address Selection

When communicating with multiple PMBus devices on a single bus, each device must have its own unique address so the host can distinguish between the devices. Set the device address using a 1% resistor on the SA pin according to the pin-strap options listed in [Table 2](#).

TABLE 2. RESISTOR VALUES TO ADDRESS MAPPING

R SA (Ω)	PMBus ADDRESS	R SA (Ω)	PMBus ADDRESS
0	60h	1500	50h
180	61h	1800	51h
330	64h	2200	54h
470	65h	2700	55h
680	40h	3300	58h
820	41h	3900	59h
1000	44h	4700	5Ch
1200	45h	5600	5Dh

Phase Configuration

The ISL68127 supports up to two regulated outputs through seven configurable phases. Either output is capable of controlling up to seven phases in any arbitrary mix. Phase assignments are accomplished using PowerNavigator.

Although the device supports arbitrary phase assignment, it is good practice to assign phases to Output 1 in descending sequential numerical order starting from Phase 6. For example, a 4-phase rail should consist of Phases 6, 5, 4, and 3. For Output 0, assign phases starting from Phase 0 in ascending sequential numerical order.

Automatic Phase Add and Drop

Automatic phase adding and dropping produces the most optimal efficiency across a wide range of output loading. The automatic phase dropping feature is optional. If automatic phase dropping is enabled, the number of active phases at any time is determined solely by load current. During operation, the Output 1 Phases drop beginning with the lowest phase number assigned. Phase dropping begins with the highest assigned phase number. [Figure 8](#) illustrates the typical characteristic of efficiency vs load current vs phase count.

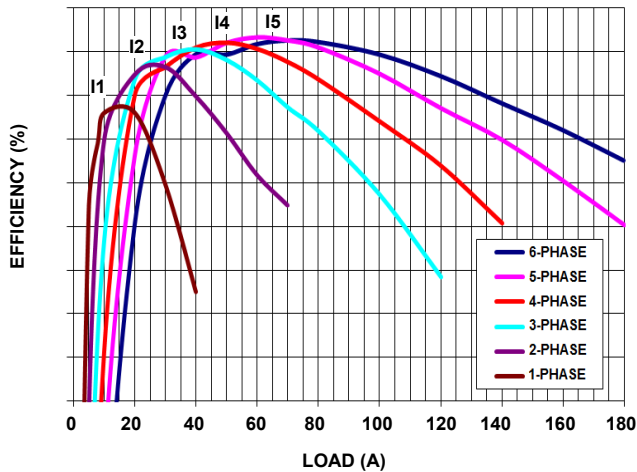

FIGURE 8. EFFICIENCY vs PHASE NUMBER

Phases are dropped one at a time with a user-programmed drop delay between drop events. As an example, suppose the delay is set to 1ms and three phases are active. If the load suddenly drops to a level needing only one phase, the ISL68127 begins by dropping a phase after 1ms. The ISL68127 then drops an additional phase each 1ms until only one phase remains.

FAST PHASE ADD FUNCTION

The fast phase add function provides a very rapid response to transient load conditions. The ISL68127 continuously monitors the system regulation error and readies all dropped phases for use if the system regulation error exceeds the user set threshold. There is no delay if all phases are needed to support a load transient. The fast phase add threshold is set in PowerNavigator. You can also configure the output current threshold for adding and dropping phases in PowerNavigator.

To ensure dropped phases have sufficient boot capacitor charge to turn on the high-side MOSFET after a long period of disable, a boot refresh circuit turns on the low-side MOSFET of each dropped phase to refresh the boot capacitor. The boot refresh frequency is programmable in PowerNavigator.

Output Voltage Configuration

Configure the output voltage set points and thresholds for each output in PowerNavigator. You can configure parameters such as output voltage, V_{OUT} margin high/low, and V_{OUT} OV/UV fault thresholds. You can also adjust output voltage and margin high/low during regulation using the PMBus commands $V_{OUT_COMMAND}$, $V_{OUT_MARGIN_HIGH}$, and $V_{OUT_MARGIN_LOW}$ for further tuning.

Maintain the following V_{OUT} relationships for correct operation: $V_{OUT_OV_FAULT_LIMIT} > V_{OUT_COMMAND}$ ($V_{OUT_MARGIN_HIGH}$ and $V_{OUT_MARGIN_LOW}$, if used) $> V_{OUT_UV_FAULT_LIMIT}$. Additionally, the V_{OUT} commands are bounded by V_{OUT_MAX} and V_{OUT_MIN} to provide protection against incorrect set points being sent to the device.

Switching Frequency

The switching frequency is user-configurable over a range of 200kHz to 1MHz.

Current Sensing

The ISL68127 supports DCR, resistor, and smart power stage current sensing. Connect to the various sense elements using the CS and CSRTN pins. Current sensing inputs are high impedance differential inputs to reject noise and ground related inaccuracies.

To accommodate a wide range of effective sense resistance, PowerNavigator uses information about the effective sense resistance and required per phase current capability to properly configure the current sense circuitry.

INDUCTOR DCR SENSING

DCR sensing takes advantage of the fact that an inductor winding has a resistive component (DCR) that drops a voltage proportional to the inductor current. [Figure 9](#) shows that the DCR is treated as a lumped element with one terminal inaccessible for measurement.

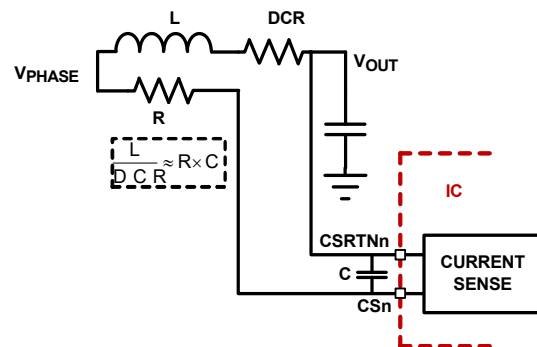

FIGURE 9. DCR SENSING CONFIGURATION

Fortunately, a simple R-C network as shown in [Figure 10 on page 14](#) can reproduce the hidden DCR voltage. By matching the R-C time constant to the L/DCR time constant, you can precisely recreate the DCR voltage across the capacitor. This means that $V_{DCR}(t) = V_C(t)$, preserving even the high frequency characteristic of the DCR voltage.

Modern inductors often have such low DCR values that the resulting signal is $<10\text{mV}$. To avoid noise problems, take care in the PCB layout to properly place the R-C components and route the differential lines between the controller and inductor. [Figure 9](#) shows one PCB design method that places the R component near the inductor V_{PHASE} and the C component very close to the IC pins. This minimizes routing of the noisy V_{PHASE} and maximizes filtering near the IC. Route the lines between the inductor and IC as a pair on a single layer directly to the controller. Avoid routing the pair near any switching signals such

as Phase and PWM. This is the method used by Renesas on evaluation board designs.

This method senses the resistance of a metal winding in which the DCR value increases with temperature. The temperature must be compensated or the sensed (and reported) current increases with temperature. To compensate the temperature effect, the ISL68127 provides temperature sensing options and an internal methodology to apply the correction.

RESISTIVE SENSING

For more accurate current sensing, a dedicated current sense resistor, R_{SENSE} , in series with each output inductor can serve as the current sense element. However, this technique reduces the overall converter efficiency due to the additional power loss on the current sense element, R_{SENSE} . A current sensing resistor has a distributed parasitic inductance, known as Equivalent Series Inductance (ESL), typically less than 4nH. Consider the ESL as a separate lumped quantity, as shown in [Figure 10](#)

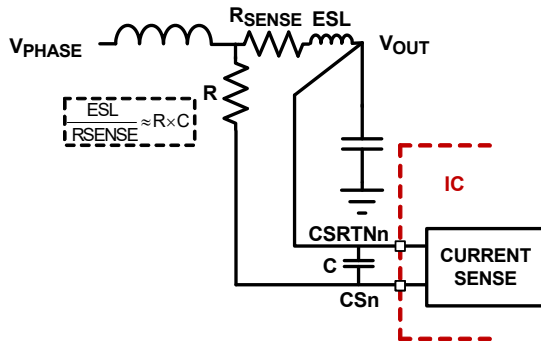

FIGURE 10. SENSE RESISTOR IN SERIES WITH INDUCTOR

The phase current I_L , flowing through the inductor, also passes through the ESL. Similar to [“Inductor DCR Sensing” on page 13](#), a simple R-C network across the current sense resistor extracts the R_{SENSE} voltage. Match the ESL/R_{SENSE} time constant to the R-C time constant.

[Figure 11](#) shows the sensed waveforms with and without matching RC when using resistive sense. The PCB layout should be similar to that described in [“Inductor DCR Sensing”](#).

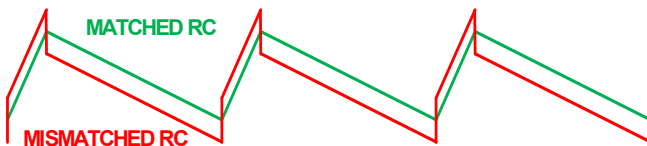

FIGURE 11. VOLTAGE ACROSS R WITH AND WITHOUT R-C

L/DCR OR ESL/RSEN MATCHING

If the compensator design is correct, [Figure 12](#) shows the expected load transient response waveforms if L/DCR or ESL/R_{SEN} is matching the R-C time constant.

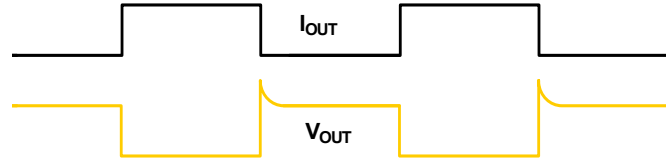

FIGURE 12. DESIRED LOAD TRANSIENT RESPONSE WAVEFORMS

When the load current I_{OUT} has a square change, the output voltage V_{OUT} also has a square response, except for the potential overshoot at load release. However, there is always some uncertainty in the true parameter values involved in the time constant matching and therefore fine-tuning is generally required.

If the R-C time constant is too large or too small, $V_C(t)$ does not accurately represent real-time $I_{OUT}(t)$ and reduces the transient response. [Figure 13](#) shows the load transient response when the R-C timing constant is too small.

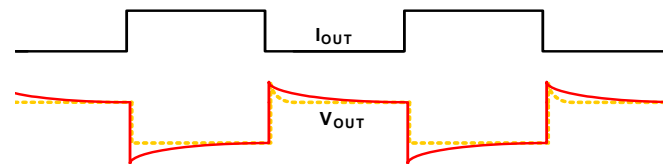

FIGURE 13. LOAD TRANSIENT RESPONSE WHEN R-C TIME CONSTANT IS TOO SMALL

In this condition, V_{OUT} sags excessively at load insertion and can create a system failure or early overcurrent trip. [Figure 14](#) shows the transient response when the R-C timing constant is too large. V_{OUT} is sluggish in drooping to its final value. Use these general guides if fine-tuning is needed.

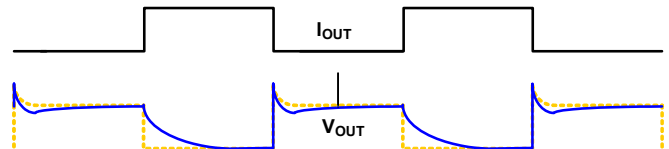

FIGURE 14. LOAD TRANSIENT RESPONSE WHEN R-C TIME CONSTANT IS TOO LARGE

SPS CURRENT SENSING

SPS current is sensed by sensing each SPS IMON output individually using VCCS as a common reference. Complete the following steps to sense SPS current.

1. Connect all SPS IREF input pins and all ISL68127 CSRTNn input pins together and tie them to VCCS.
2. Connect the SPS IMONn output pins to the corresponding ISL68127 CSn input pins. The signals should be run as differential pairs from the SPS back to the ISL68127.

Temperature Sensing

The ISL68127 supports temperature sensing through BJT or smart power stage sense elements. Support for BJT sense elements uses the delta Vbe method and allows up to two sensors (MMBT3906 or similar) on each temperature sense input, TMON0 and TMON1. Support for smart power stage uses a linear conversion algorithm and allows one sensor reading per pin. The conversion from voltage to temperature for smart power stage sensing is user-programmable in PowerNavigator.

SPS temperature sensing measures the temperature-dependent voltage output on the SPS TMON pin. All of the SPS devices attached to the Output 0 rail have their TMON pins connected to the ISL68127 TMON0 pin. All of the SPS devices attached to the Output 1 rail have their TMON pins connected to the ISL68127 TMON1 pin. The reported temperature is that of the highest temperature SPS of the group.

In addition to the external temperature sense, the IC senses its own die temperature, which can be monitored in PowerNavigator.

Sensed temperature is used in the system for faults, telemetry, and sensed current temperature compensation.

Temperature Compensation

The ISL68127 supports inductor DCR sensing, which generally requires temperature compensation due to the copper wire used to form inductors. Copper has a positive temperature coefficient of approximately 0.39%/°C. Because the voltage across the inductor is sensed for the output current information, the sensed current has the same positive temperature coefficient as the inductor DCR.

Compensating current sense for temperature variation generally requires that the current sensing element temperature and its temperature coefficient is known. Although the temperature coefficient is generally obtained easily, actual current sense element temperature is essentially impossible to measure directly. Instead, a temperature sensor (a BJT for the ISL68127) placed near the inductors is measured and the current sense element (DCR) temperature is calculated from that measurement. Calculating current sense element temperature is equivalent to applying gain and offset corrections to the temperature sensor measurement. The ISL68127 supports both corrections.

Figure 15 shows the temperature compensation block diagram.

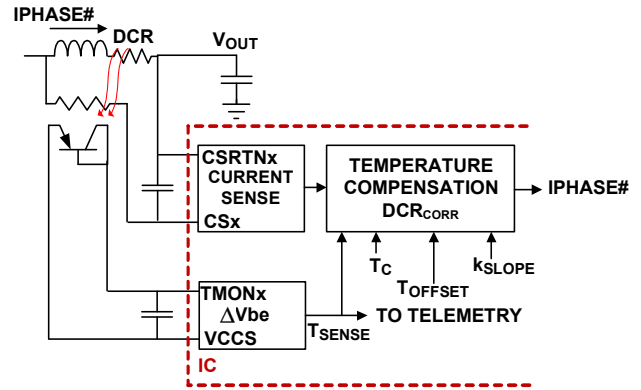

FIGURE 15. TEMPERATURE COMPENSATION BLOCK DIAGRAM

The IC monitors a BJT near the inductors used for DCR sensing using the delta Vbe temperature sensing method. TSENSE is the direct measured temperature of the BJT. Because the BJT is not directly sensing DCR, corrections must be made so that TDCR reflects the true DCR temperature. Corrections are applied according to the relationship shown in Equation 1, where kSLOPE represents a gain scaling and TOFFSET represents an offset correction. Configure these parameters in PowerNavigator:

$$T_{DCR} = k_{SLOPE} \cdot T_{SENSE} + T_{OFFSET} \quad (EQ. 1)$$

After calculating TDCR, determine the compensated DCR value with Equation 2, where DCR25 is the DCR at +25°C and Tc is the temperature coefficient of copper (3900 ppm/°C).

$$T_{DCR} = T_{ACTUAL}$$

$$DCR_{CORR} = DCR_{25} \cdot (1 + T_c \cdot (T_{ACTUAL} - 25)) \quad (EQ. 2)$$

The temperature-compensated DCR is now used to determine the actual value of current in the DCR sense element.

In the physical PCB design, place the temperature sense diode (BJT) close to the inductor of the phase that is never dropped during automatic phase drop operation. Additionally, add a filter capacitor no larger than 500pF near the IC between each TMONx pin and VCCS (see Figure 16).

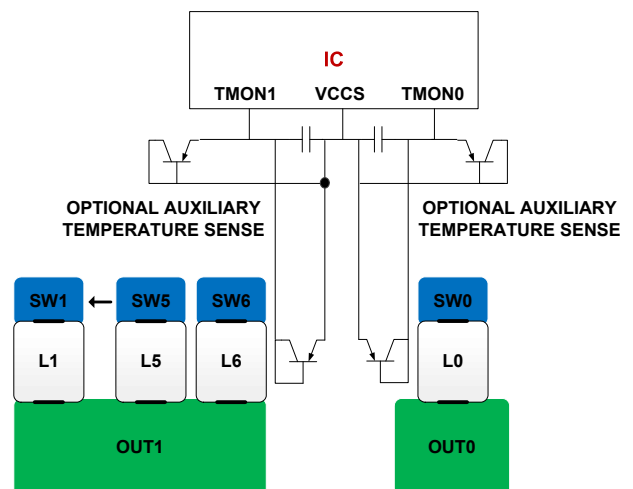

FIGURE 16. RECOMMENDED PLACEMENT OF TEMPERATURE SENSORS

Lossless Input Current and Power Sensing

Input current telemetry is provided through an input current synthesizer. By using the IC's ability to precisely determine its operational conditions, the input current can be synthesized to a high degree of accuracy without the need for a lossy sense resistor. You can fine-tune offset and gain in PowerNavigator. Note that input current sense must be fine-tuned after the output current sense setup is finalized. You can calculate input power with a precise knowledge of input current and voltage.

Input current and power telemetry is accessed through PMBus and easily monitored in PowerNavigator. V_{IN} is monitored directly by the VINSEN pin through a 1:5 resistor divider as shown in [Figure 17](#).

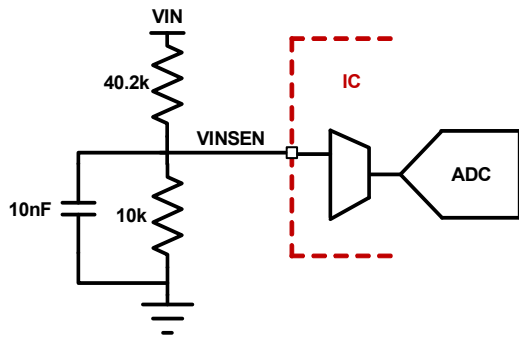

FIGURE 17. INPUT VOLTAGE SENSE CONFIGURATION

Voltage Regulation

The remote sense amplifier senses and digitizes the output voltage. After digitization, the regulation loop is entirely digital. The ISL68127 uses traditional PID controls and several enhanced methods to compensate the voltage regulation loop and tune the transient response.

Current Feedback

Current feedback in a voltage regulator is often used to ease the stability design of the voltage feedback path. Additionally, many microprocessors require the voltage regulator to have a controlled output resistance (known as load line or droop regulation), which is accomplished using current feedback.

For applications requiring droop regulation, specify the output resistance in PowerNavigator.

Current feedback stability benefits are available for rails that do not specify droop regulation, such as system agent. For these applications, you can enable AC current feedback in PowerNavigator. With this configuration, the DC output voltage is steady regardless of load current.

Power-On Reset (POR)

ISL68127 initialization begins after V_{CC} crosses its rising POR threshold. When POR conditions are met, the internal 1.2V LDO is enabled and basic digital subsystem integrity checks begin. During this process, the controller loads the selected user configuration from NVM as indicated by the CONFIG pin resistor value, read V_{IN} UVLO thresholds from memory, and start the telemetry subsystem. With telemetry enabled, you can monitor V_{IN} determine when it exceeds its user-programmable rising

UVLO threshold. When V_{CC} and V_{IN} satisfy their respective voltage conditions, the controller is in its shutdown mode. The controller transitions to its active state and begins soft-start when the EN0/EN1 command is at start-up. In shutdown mode, the PWM outputs are held in a high-impedance state to ensure the drivers remain off.

Soft-Start Delay and Ramp Times

It may be necessary to set a delay from when an enable signal is received until the output voltage starts to ramp to its target value. In addition, you can precisely set the time required for an output to ramp to its target value after the delay period has expired. These features can be used as part of an overall inrush current management strategy or to precisely control how fast a load IC is turned on. The ISL68127 provides several options for precisely and independently controlling both the delay and ramp time periods. The soft-start delay period begins when the EN pin is asserted and ends when the delay time expires.

Use PowerNavigator to configure the soft-start delay and ramp-up/down times. The device needs approximately 200 μ s after enable to initialize before starting to ramp up. When the soft-start ramp period is set to 0ms, the output ramps up as quickly as the output load capacitance and loop settings allow. Renesas recommends setting the ramps to a non-zero value to prevent inadvertent fault conditions due to excessive inrush current.

Stored Configuration Selection

You can store and use up to eight configurations at any time using the on-board nonvolatile memory. Configurations are assigned an identifier number between 0 and 7 at power-up. The device loads the configuration indicated by the 1% resistor value detected on the CONFIG pin. Resistor values indicate use of one of the eight possible configurations. See [Table 3](#) for the resistor value corresponding to each configuration identifier.

TABLE 3. RESISTOR VALUES TO CONFIGURATION MAPPING

R CONFIG (Ω)	CONFIG ID
6800	0
1800	1
2200	2
2700	3
3300	4
3900	5
4700	6
5600	7

Only the most recent configuration with a given number can be loaded. The device supports a total of eight stored operations. For example, a configuration with the identifier 0 can be saved eight times, or configurations with all eight identifiers can be stored one time each for a total of eight save operations.

PowerNavigator provides a simple interface to save and load configurations.

Fault Monitoring and Protection

The ISL68127 actively monitors temperature, input voltage, output voltage, and output current to detect and report fault conditions. Fault monitors trigger configurable protective measures to prevent damage to a load. The power-good indicators, PG0/PG1, can link to external system monitors.

A high level of flexibility is provided in the ISL68127 fault logic. Faults can be enabled or disabled individually. Each fault type can also be configured to either latch off or retry indefinitely.

Power-Good Signals

The PG0/PG1 pins are open-drain, power-good outputs that indicate completion of the soft-start sequence and output voltage of the associated rail within the expected regulation range.

The PG pins can be associated or disassociated with a number of the available fault types. This allows a system design to be tailored for virtually any condition. In addition, these power-good indicators are pulled low when a fault (OCP or OVP) condition or UV condition is detected on the associated rail.

Output Voltage Protection

Output voltage is measured at the load sensing points differentially for regulation and the same measurement is used for OVP and UVP. The fault thresholds are set using PMBus commands. Figure 18 shows a simplified OVP/UVP block diagram. The output voltage comparisons occur in the digital domain.

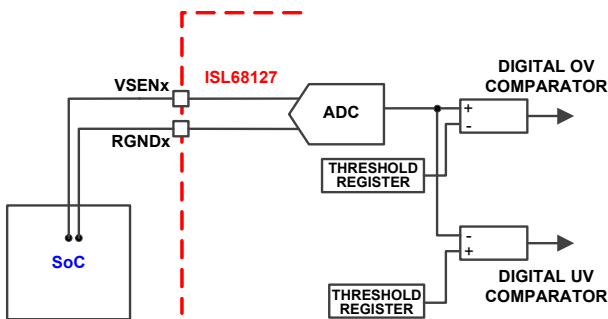

FIGURE 18. OVP, UVP COMPARATORS

The device responds to an output overvoltage condition by disabling the output, declaring a fault, setting the SALRT pin, setting the PG pin, and pulsing the LFET until the output voltage drops below the threshold. Similarly, the device responds to an output undervoltage condition by disabling the output, declaring a fault, setting the SALRT pin, and setting the PG pin. The output does not restart until the EN pin is cycled (unless the device is configured to retry).

The ISL68127 also features open pin sensing protection to detect an open of the output voltage sensing circuit. Controller operation is suspended if an open of the output voltage sensing circuit is detected.

Output Current Protection

The ISL68127 provides a comprehensive overcurrent protection scheme. Each phase is protected from both excessive peak current and sustained current and the system is protected from sustained total output overcurrent.

Figure 19 shows a block diagram of the system total output current protection scheme. In this scheme, the phase currents are summed to form ISUM. ISUM is then fed to dual response paths allowing you to program separate LPF, threshold, and response time.

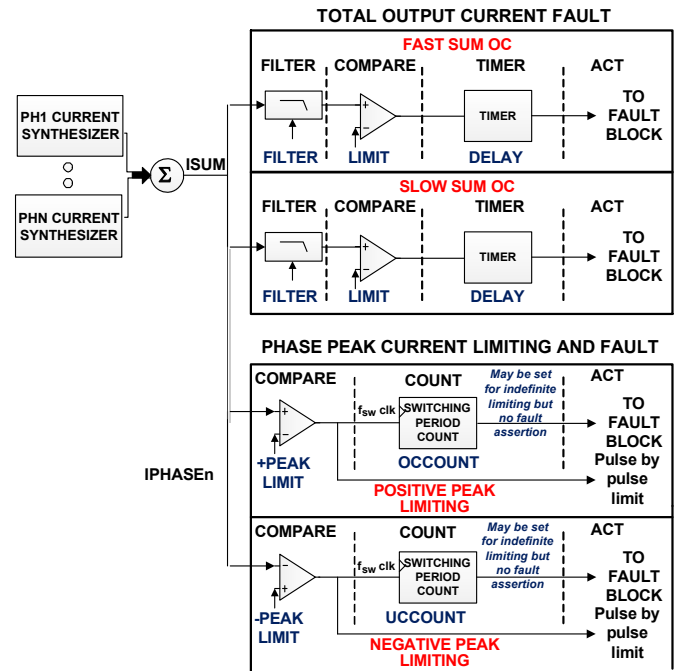

FIGURE 19. OCP FUNCTIONAL DIAGRAM

The Fast Sum OC path responds more quickly than the Slow Sum OC path. With this system, you can allow high peak total current for a short time and a lower level of current for a sustained time. Note that neither of these paths affect PWM activity on a cycle-by-cycle basis. Set the characteristics of each path in PowerNavigator.

In addition to total output current, the ISL68127 provides an individual phase peak current limit that acts on PWM in a cycle-by-cycle manner. If a phase current exceeds the OC threshold, the phase PWM signal is inverted to move current away from the threshold. In addition to limiting positive or negative peak current on a cycle-by-cycle basis, the individual phase OC can be configured to limit current indefinitely or to declare a fault after a programmable number of consecutive OC cycles. This feature is useful for applications in which a fault shutdown of the system is not acceptable but some ability to limit phase currents is required. Figures 22 and 23 on page 18 show this operation.

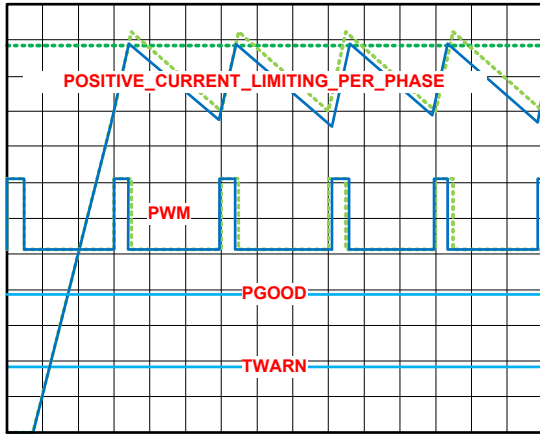

FIGURE 20. POSITIVE PEAK PHASE CURRENT LIMITING

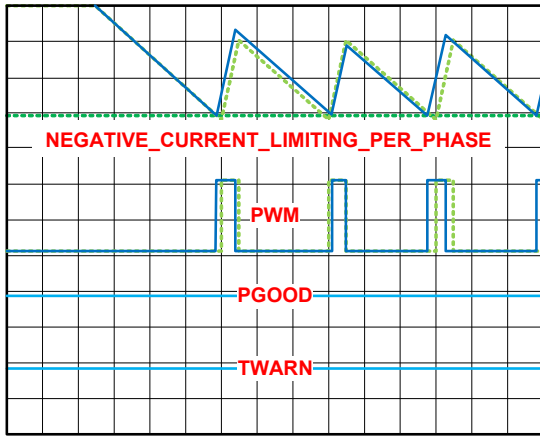

FIGURE 21. NEGATIVE PEAK PHASE CURRENT LIMITING

If configured for indefinite current limit, the converter acts as a current source and V_{OUT} does not remain at its regulation point. Note that in this case, V_{OUT} OV or UV protection action may occur, which can shut the regulator down.

Figure 22 shows an example OCP_Fast waveform and Figure 23 shows an example OCP_Slow waveform.

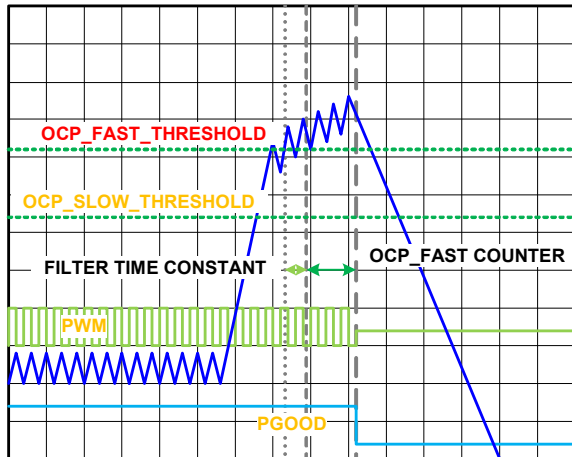

FIGURE 22. OCP_FAST

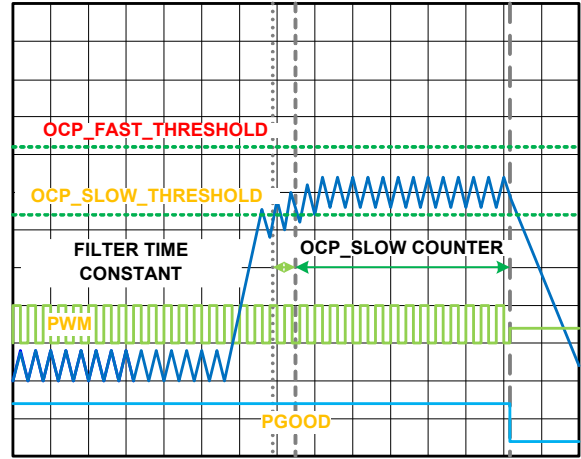

FIGURE 23. OCP_SLOW

Smart Power Stage OC Fault Detect

Renesas Smart Power Stage (SPS) devices output a large signal on their IMON lines if peak current exceeds their preprogrammed threshold (for more information about this functionality, refer to the relevant SPS datasheet). The ISL68127 is equipped to detect this fault flag and immediately shut down. This detector is enabled on the PowerNavigator Overcurrent Fault setup screen.

This feature detects signals that exceed the current sense ADC full scale range. If this detector is disabled while using a Renesas SPS, the SPS Fault# signal must be connected to the controller Enable pin of the associated rail, ensuring that SPS OC events are detected and the converter shuts down.

Thermal Monitoring and Protection

The TWARN pin indicates the voltage regulator temperature status. The TWARN pin is an open-drain output and an external pull-up resistor is required. This signal is valid only after the controller is enabled.

The TWARN signal can inform the system that the voltage regulator temperature is too high and the load should reduce its power consumption. TWARN only indicates a thermal warning, not a fault.

Figure 24 shows the thermal monitoring function block diagram.

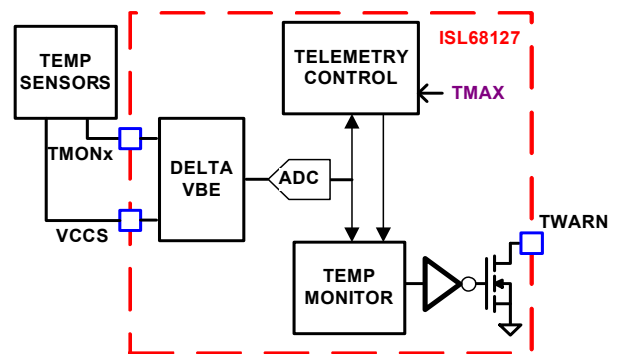

FIGURE 24. BLOCK DIAGRAM OF THERMAL MONITORING FUNCTION

The ISL68127 has two over-temperature thresholds that allow both warning and fault indications. Each temperature sensor threshold can be independently programmed in PowerNavigator. [Figure 25](#) shows the thermal warning to TWARN and [Figure 26](#) shows the over-temperature fault to shutdown. You can configure PGOOD and TWARN to indicate these warning and fault thresholds using PowerNavigator.

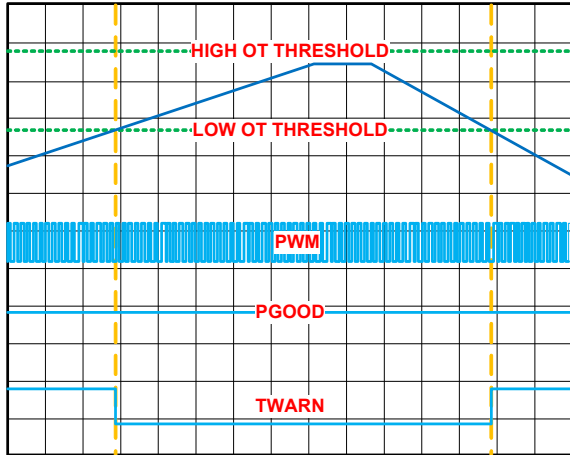

FIGURE 25. THERMAL WARNING TO TWARN

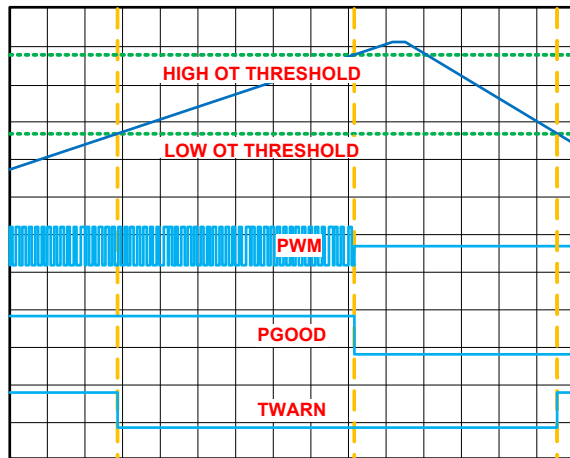

FIGURE 26. OVER-TEMPERATURE FAULT

Layout and Design Considerations

The following PCB layout and design strategies minimize noise coupling and the impact of board parasitic impedances on converter performance, and optimize the heat dissipation capabilities of the PCB. See [TB379](#) for more information. Follow these important practices during the layout process.

[Table 4](#) provides general guidance on best practices related to pin noise sensitivity. Good engineering judgment is required to implement designs based on criteria specific to the situation.

TABLE 4. PIN DESIGN AND/OR LAYOUT CONSIDERATIONS

PIN NAME	NOISE SENSITIVE	DESCRIPTION
VINSEN	Yes	Connects to the resistor divider between VIN and GND (see Figure 17). Filter VINSEN with 10nF to GND.
RGNDx VSENx	Yes	Treat each of the remote voltage sense pairs as differential signals in the PCB layout. Route the pairs side by side on the same layer. Do not route the pairs in close proximity to noisy signals such as PWM or Phase. Tie to ground when not used.
PGx	No	Open-drain, 3.3V maximum pull-up voltage. Tie to ground when not used.
SCL, SDA, SALRT	Yes	50kHz to 2MHz signal during communication. Pair with SALRT and route carefully. Provide 20 mils spacing within SDA, SALRT, and SCL; and more than 30 mils spacing to all other signals. Refer to the SMBus design guidelines and place proper termination resistance for impedance matching. Tie to ground when not used.
TMON ^x	Yes	When diode sensing is used, VCCS is the return path for the delta Vbe currents. Use a separate VCCS route specifically for diode temp sense. Place a filter capacitor no greater than 500pF between each TMON pin and at the VCCS pin near the IC. Tie to ground when not used.
TWARN	No	Open-drain. 3.3V maximum pull-up voltage.
VCC	Yes	Place a MLCC decoupling capacitor (at least 2.2µF) directly at the pin.
VCCS	Yes	Place a 4.7 µF MLCC decoupling capacitor directly at the pin.
PWM	No	Avoid routing near noise sensitive analog lines such as current sense or voltage sense.
CSx CSRTN ^x	Yes	Treat each of the current sense pairs as differential signals in the PCB layout. Route the pairs side by side on the same layer. DO not route the pairs in close proximity to noisy signals such as PWM or Phase. Note: Proper current sense routing is perhaps the most critical of all the layout tasks.
GND	Yes	This EPAD is the return of the PWM output drivers. Use four or more vias to directly connect the EPAD to the power ground plane.
General Comments		The layer next to the top or bottom layer should be a ground layer. The signal layers should be sandwiched in the ground layers if possible.

PMBus Operation

The ISL68127 PMBus slave address is pin selectable using the SA pin and resistor value described in [Table 2 on page 12](#). For proper operation, follow the PMBus protocol in [“PMBus Protocol” on page 21](#). The supported PMBus addresses are in 8-bit format, including the write and read bit (see [Table 5](#)). The least significant bit of the 8-bit address is for write (0h) and read (1h). PMBus commands are in the range from 0x00h to 0xFFh. Page 0 corresponds to Output 0 and Page 1 corresponds to Output 1. For reference purposes, the 7-bit format addresses are also summarized in [Table 5](#).

TABLE 5. PMBus 8-BIT AND 7-BIT FORMAT ADDRESS (HEX)

8-BIT	7-BIT	8-BIT	7-BIT	8-BIT	7-BIT	8-BIT	7-BIT
80/81	40	A0/A1	50	B0/B1	58	C0/C1	60
82/83	41	A2/A3	51	B2/B3	59	C2/C3	61
88/89	44	A8/A9	54	B8/B9	5C	C8/C9	64
8A/8B	45	AA/AB	55	BA/BB	5D	CA/CB	65

The PMBus data formats follow PMBus specification V1.3 and SMBus V2.0.

The basic PMBus telemetry commands are summarized in [“PMBus Command Summary” on page 22](#).

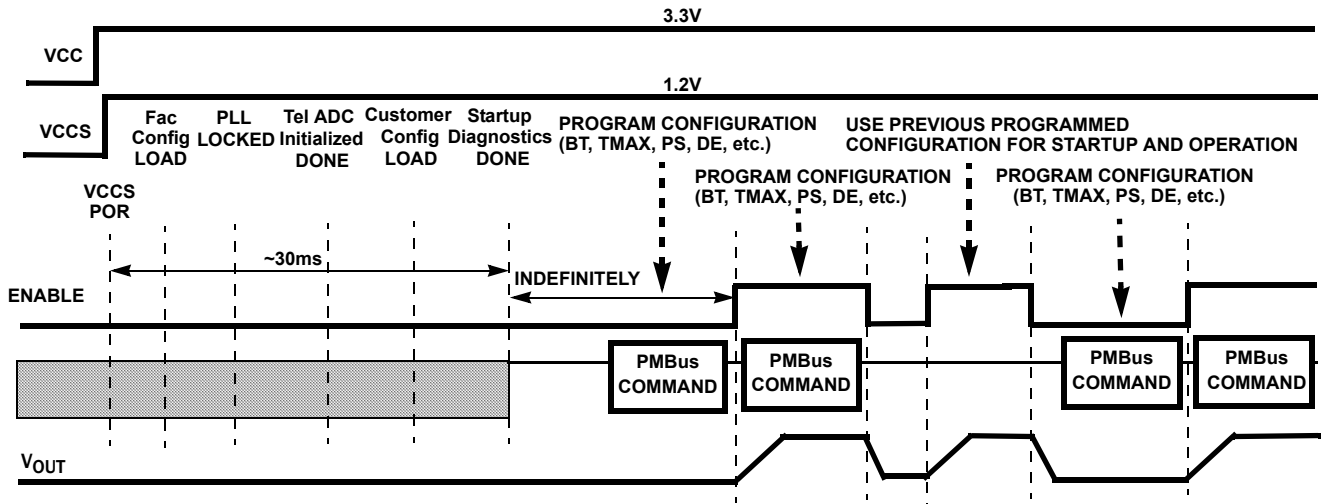
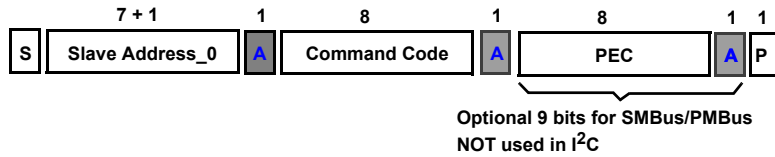

FIGURE 27. SIMPLIFIED PMBus INITIALIZATION TIMING DIAGRAM

PMBus Protocol

1. Send Byte Protocol



- S: Start Condition
- A: Acknowledge ("0")
- N: Not Acknowledge ("1")
- W: Write ("0")
- RS: Repeated Start Condition
- R: Read ("1")
- PEC: Packet Error Checking
- P: Stop Condition

Example command: 03h Clear Faults
(This clears all of the bits in Status Byte for the selected rail)

Acknowledge or DATA from Slave, ISL68127 Controller

2. Write Byte/Word Protocol

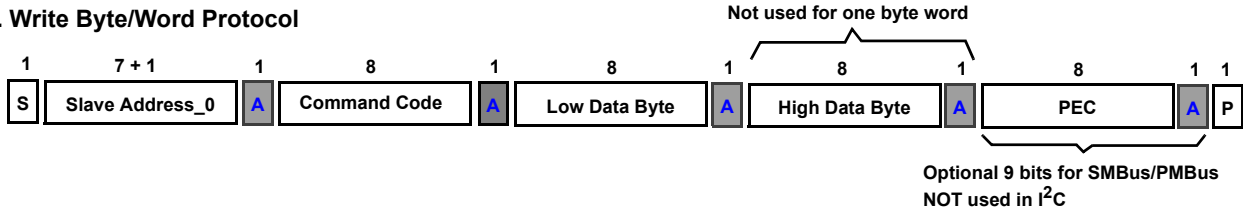

Example command: 21h VOUT_COMMAND

3. Read Byte/Word Protocol

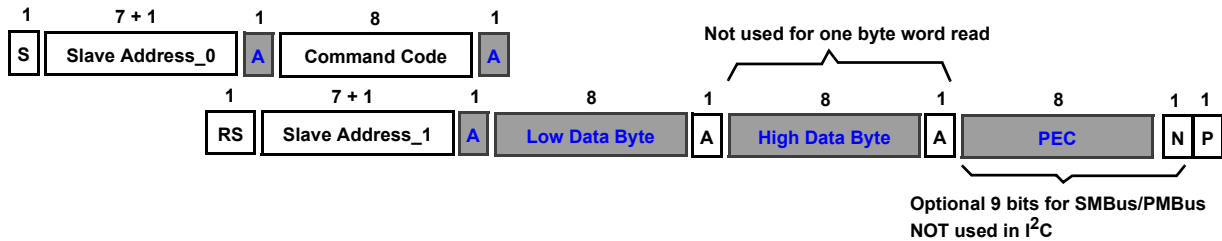

Example command: 8B READ_VOUT (Two words, read voltage of the selected rail).

The STOP (P) bit is NOT allowed before the repeated START condition when "reading" contents of a register.

4. Group Command Protocol - No more than one command can be sent to the same Address

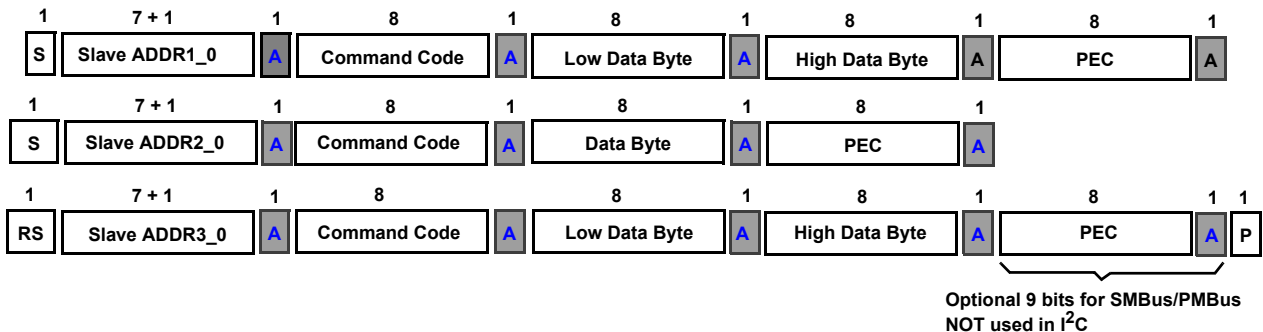

5. Alert Response Address (ARA, 0001_1001, 25h) for SMBus and PMBus, not used for I2C

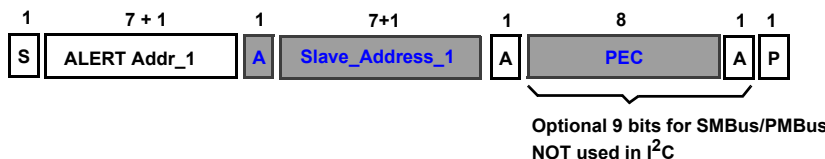

PMBus Command Summary

CODE	COMMAND NAME	DESCRIPTION	TYPE	DATA FORMAT	DEFAULT VALUE	DEFAULT SETTING
00h	PAGE	Selects Output 0, 1, or both	R/W	Bit Field	00h	Page 0
01h	OPERATION	Enable/disable, margin settings	R/W	Bit Field	08h	Off
02h	ON_OFF_CONFIG	On/off configuration settings	R/W	Bit Field	16h	ENABLE pin control
03h	CLEAR_FAULTS	Clears all fault bits in all registers and releases the SALRT pin	Write	N/A	N/A	
10h	WRITE_PROTECT	Gives write protection to sets of commands	R/W	Bit Field	00h	No write protection
20h	VOUT_MODE	Defines the format for output voltage related commands	Read	Bit Field	40h	Direct format
21h	VOUT_COMMAND	Sets the nominal V_{OUT} target	R/W	Direct	0384h	900mV
22h	VOUT_TRIM	Applies trim voltage to V_{OUT} set-point	R/W	Direct	0000h	0mV
24h	VOUT_MAX	Absolute maximum voltage setting	R/W	Direct	08FCh	2300mV
25h	VOUT_MARGIN_HIGH	Sets V_{OUT} target during margin high	R/W	Direct	0640h	1600mV
26h	VOUT_MARGIN_LOW	Sets V_{OUT} target during margin low	R/W	Direct	00FAh	250mV
27h	VOUT_TRANSITION_RATE	Slew rate setting for V_{OUT} changes	R/W	Direct	0064h	10mV/ μ s
28h	VOUT_DROOP	Sets the load line (V/I slope) resistance for the output	R/W	Direct	0000h	0 μ V/A
2Bh	VOUT_MIN	Absolute minimum target voltage setting	R/W	Direct	0000h	0mV
40h	VOUT_OV_FAULT_LIMIT	Sets the V_{OUT} overvoltage fault threshold	R/W	Direct	076Ch	1900mV
44h	VOUT_UV_FAULT_LIMIT	Sets the V_{OUT} undervoltage fault threshold	R/W	Direct	0000h	0mV
4Fh	OT_FAULT_LIMIT	Sets the over-temperature fault threshold	R/W	Direct	007Dh	+125 °C
51h	OT_WARN_LIMIT	Sets the over-temperature warn threshold	R/W	Direct	07D0h	+2000 °C
55h	VIN_OV_FAULT_LIMIT	Sets the V_{IN} overvoltage fault threshold	R/W	Direct	36B0h	14,000mV
59h	VIN_UV_FAULT_LIMIT	Sets the V_{IN} undervoltage fault threshold	R/W	Direct	1F40h	8,000mV
5Bh	IIN_OC_FAULT_LIMIT	Sets the I_{IN} overcurrent fault threshold	R/W	Direct	0032h	50A
60h	TON_DELAY	Sets the delay time from enable to V_{OUT} rise	R/W	Direct	0014h	200 μ s
61h	TON_RISE	Turn-on rise time	R/W	Direct	01F4h	500 μ s
64h	TOFF_DELAY	Turn-off delay time	R/W	Direct	0000h	0 μ s
65h	TOFF_FALL	Turn-off fall time	R/W	Direct	01F4h	500 μ s
78h	STATUS_BYTE	First byte of STATUS_WORD	Read	Bit Field	N/A	N/A
79h	STATUS_WORD	Summary of critical faults	Read	Bit Field	N/A	N/A
7Ah	STATUS_VOUT	Reports V_{OUT} faults	Read	Bit Field	N/A	N/A
7Bh	STATUS_IOUT	Reports I_{OUT} faults	Read	Bit Field	N/A	N/A
7Ch	STATUS_INPUT	Reports input faults	Read	Bit Field	N/A	N/A
7Dh	STATUS_TEMPERATURE	Reports temperature warnings/faults	Read	Bit Field	N/A	N/A
7Eh	STATUS_CML	Reports communication, memory, and logic errors	Read	Bit Field	N/A	N/A
80h	STATUS_MFR_SPECIFIC	Reports specific events	Read	Bit Field	N/A	N/A
88h	READ_VIN	Reports input voltage measurement	Read	Direct	N/A	N/A
89h	READ_IIN	Reports input current measurement	Read	Direct	N/A	N/A
8Bh	READ_VOUT	Reports output voltage measurement	Read	Direct	N/A	N/A
8Ch	READ_IOUT	Reports output current measurement	Read	Direct	N/A	N/A

PMBus Command Summary (Continued)

CODE	COMMAND NAME	DESCRIPTION	TYPE	DATA FORMAT	DEFAULT VALUE	DEFAULT SETTING
8Dh	READ_TEMPERATURE_1	Reports power stage temperature measurement	Read	Direct	N/A	N/A
8Eh	READ_TEMPERATURE_2	Reports TMON0 temperature measurement	Read	Direct	N/A	N/A
8Fh	READ_TEMPERATURE_3	Reports TMON1 temperature measurement	Read	Direct	N/A	N/A
96h	READ_POUT	Reports output power	Read	Direct	N/A	N/A
97h	READ_PIN	Reports input power	Read	Direct	N/A	N/A
98h	PMBUS_REVISION	Reports specific events	Read	Bit Field	33h	Revision 1.3
ADh	IC_DEVICE_ID	Reports device identification information	Block Read	Bit Field	49D22800h	ISL68127
A Eh	IC_DEVICE_REV	Reports device revision information	Block Read	Bit Field	N/A	N/A
E7h	APPLY_SETTINGS	Instructs device to apply PMBus configuration changes	Write	Bit Field	N/A	N/A
F2h	RESTORE_CONFIG	Allows selection of configurations from NVM	Write	Bit Field	N/A	N/A

PMBus Use Guidelines

All commands can be read at any time.

Always disable the outputs when writing commands that change device settings. Exceptions to this rule are commands intended to be written while the device is enabled, for example, OPERATION.

PMBus Data Formats

Direct (D)

The Direct data format is a 2-byte two's complement binary integer.

Bit Field (BIT)

A description of Bit Field is provided in ["PMBus Command Detail" on page 24](#).

PMBus Command Detail

PAGE (00h)

Definition: Selects Controller 0, Controller 1, or both Controllers 0 and 1 to receive commands. All commands following this command are received and acted on by the selected controller or controllers.

Data Length in Bytes: 1

Data Format: Bit Field

Type: R/W

Default Value: 00h

COMMAND	PAGE (00h)							
Format	Bit Field							
Bit Position	7	6	5	4	3	2	1	0
Access	R/W	R/W	R/W	R/W	R/W	R/W	R/W	R/W
Function	See Following Table							
Default Value	0	0	0	0	0	0	0	0

BITS 7:4	BITS 3:0	PAGE
0000	0000	0
0000	0001	1
1111	1111	Both

OPERATION (01h)

Definition: Sets the enable state when configured for PMBus enable. Sets output voltage margin settings. The device always acts on faults during margin. The following table reflects the valid settings for the device.

Paged or Global: Paged

Data Length in Bytes: 1

Data Format: Bit Field

Type: R/W

Default Value: 08h

COMMAND	OPERATION (01h)							
Format	Bit Field							
Bit Position	7	6	5	4	3	2	1	0
Access	R/W	R/W	R/W	R/W	R/W	R/W	R/W	R/W
Function	See Following Table							
Default Value	0	0	0	0	1	0	0	0

BIT NUMBER	PURPOSE	BIT VALUE	MEANING
Bits 7:6	Enable/Disable	00	Immediate off (decay)
		01	Soft-off (Use TOFF_DELAY and TOFF_FALL)
		10	On
Bits 5:4	V _{OUT} Source	00	VOUT_COMMAND
		01	VOUT_MARGIN_LOW
		10	VOUT_MARGIN_HIGH
		11	Not used
Bits 3:2	Margin Response	10	Act on faults
Bit 1:0	Not Used	0	Not used

ON_OFF_CONFIG (02h)

Definition: Configures the interpretation of the "[OPERATION \(01h\)](#)" command and the ENABLE pin (EN).

Paged or Global: Global

Data Length in Bytes: 1

Data Format: Bit Field

Type: R/W

Default Value: 16h (ENABLE pin control)

COMMAND	ON_OFF_CONFIG (02h)							
Format	Bit Field							
Bit Position	7	6	5	4	3	2	1	0
Access	R/W	R/W	R/W	R/W	R/W	R/W	R/W	R/W
Function	See Following Table							
Default Value	0	0	0	0	0	0	0	0

BIT NUMBER	PURPOSE	BIT VALUE	MEANING
7:5	Not Used	000	Not Used
4:2	Sets the Source of Enable	000	Device always enabled regardless of pin or OPERATION command state
		101	Device starts from Enable pin only
		110	Device starts from OPERATION command only
		111	Device starts from OPERATION command AND Enable pin
1	Enable Pin Polarity	1	Active high only
0	Enable Pin Turn-Off Action	1	Turns off immediately with decay
		0	Uses programmed " TOFF_DELAY (64h) " and " TOFF_FALL (65h) " settings

CLEAR_FAULTS (03h)

Definition: Clears all fault bits in all registers and releases the SALRT pin (if asserted) simultaneously. If a fault condition still exists, the bit reasserts immediately. This command does not restart a device if it is shut down, it only clears the faults.

Paged or Global: Global

Data Length in Bytes: 0

Data Format: N/A

Type: Write Only

Default Value: N/A

WRITE_PROTECT (10h)

Definition: Sets the write protection of certain configuration commands.

Paged or Global: Global

Data Length in Bytes: 1

Data Format: Bit Field

Type: R/W

Default Value: 00h (Enable all writes)

COMMAND	WRITE_PROTECT (10h)							
Format	Bit Field							
Bit Position	7	6	5	4	3:0	2	1	0
Access	R/W	R/W	R/W	R/W	R/W	R/W	R/W	R/W
Function	See Following Table							
Default Value	0	0	0	0	0	0	0	0

SETTINGS	PROTECTION
40h	Disables all writes except to WRITE_PROTECT, "OPERATION (01h)" , "CLEAR_FAULTS (03h)" , and "PAGE (00h)"
20h	Disables all writes except all above plus "ON_OFF_CONFIG (02h)" , "VOUT_COMMAND (21h)" , and "VOUT_TRIM (22h)"
00h	Enables all writes

NOTE: Any settings other than the three shown in the table cause an invalid data fault.

VOUT_MODE (20h)

Definition: Returns the supported V_{OUT} mode. This device supports absolute direct mode only.

Paged or Global: Global

Data Length in Bytes: 1

Data Format: Bit Field

Type: Read Only

Default Value: 40h

Units: N/A

Equation: N/A

VOUT_COMMAND (21h)

Definition: Sets the value of V_{OUT} when the ["OPERATION \(01h\)"](#) command is configured for nominal operation.

Paged or Global: Paged

Data Length in Bytes: 2

Data Format: Direct

Type: R/W

Default Value: 0384h (900mV)

Units: mV

Equation: $V_{OUT_COMMAND} = (\text{Direct value})$

Range: ["VOUT_MIN \(2Bh\)"](#) to ["VOUT_MAX \(24h\)"](#)

COMMAND	VOUT_COMMAND (21h)															
Format	Direct															
Bit Position	15	14	13	12	11	10	9	8	7	6	5	4	3	2	1	0
Access	R/W	R/W	R/W	R/W	R/W	R/W	R/W	R/W	R/W	R/W	R/W	R/W	R/W	R/W	R/W	R/W
Function	Unsigned Integer															
Default Value	0	0	0	0	0	0	1	1	1	0	0	0	0	1	0	0

VOUT_TRIM (22h)

Definition: Sets a fixed trim voltage to the output voltage command value. This command is typically used to calibrate a device in the application circuit.

Paged or Global: Paged

Data Length in Bytes: 2

Data Format: Direct

Type: R/W

Default Value: 0000h (0mV)

Units: mV

Equation: $V_{OUT_TRIM} = (\text{Direct value})$

Range: $\pm 250\text{mV}$

COMMAND	VOUT_TRIM (22h)															
Format	Direct															
Bit Position	15	14	13	12	11	10	9	8	7	6	5	4	3	2	1	0
Access	R/W	R/W	R/W	R/W	R/W	R/W	R/W	R/W	R/W	R/W	R/W	R/W	R/W	R/W	R/W	R/W
Function	Two's Complement Integer															
Default Value	0	0	0	0	0	0	0	0	0	0	0	0	0	0	0	0

VOUT_MAX (24h)

Definition: Sets the maximum allowed V_{OUT} target regardless of any other commands or combinations.

Paged or Global: Paged

Data Length in Bytes: 2

Data Format: Direct

Type: R/W

Default Value: 08FCh (2300mV)

Units: mV

Equation: $V_{OUT_MAX} = (\text{Direct value})$

Range: 0mV to 3300mV

COMMAND	VOUT_MAX (24h)															
Format	Direct															
Bit Position	15	14	13	12	11	10	9	8	7	6	5	4	3	2	1	0
Access	R/W	R/W	R/W	R/W	R/W	R/W	R/W	R/W	R/W	R/W	R/W	R/W	R/W	R/W	R/W	R/W
Function	Unsigned Integer															
Default Value	0	0	0	0	1	0	0	0	1	1	1	1	1	1	0	0

VOUT_MARGIN_HIGH (25h)

Definition: Sets the value of V_{OUT} when the [“OPERATION \(01h\)”](#) command is configured for margin high.

Paged or Global: Paged

Data Length in Bytes: 2

Data Format: Direct

Type: R/W

Default Value: 0640h (1600mV)

Units: mV

Equation: $V_{OUT_MARGIN_HIGH} = (\text{Direct value})$

Range: [“VOUT_MIN \(2Bh\)”](#) to [“VOUT_MAX \(24h\)”](#)

COMMAND	VOUT_MARGIN_HIGH (25h)															
Format	Direct															
Bit Position	15	14	13	12	11	10	9	8	7	6	5	4	3	2	1	0
Access	R/W	R/W	R/W	R/W	R/W	R/W	R/W	R/W	R/W	R/W	R/W	R/W	R/W	R/W	R/W	R/W
Function	Unsigned Integer															
Default Value	0	0	0	0	0	1	1	0	0	1	0	0	0	0	0	0

VOUT_MARGIN_LOW (26h)

Definition: Sets the value of V_{OUT} when the [“OPERATION \(01h\)”](#) command is configured for margin low.

Paged or Global: Paged

Data Length in Bytes: 2

Data Format: Direct

Type: R/W

Default Value: 00FAh (250mV)

Units: mV

Equation: $V_{OUT_MARGIN_LOW} = (\text{Direct value})$

Range: [“VOUT_MIN \(2Bh\)”](#) to [“VOUT_MAX \(24h\)”](#)

COMMAND	VOUT_MARGIN_LOW (26h)															
Format	Direct															
Bit Position	15	14	13	12	11	10	9	8	7	6	5	4	3	2	1	0
Access	R/W	R/W	R/W	R/W	R/W	R/W	R/W	R/W	R/W	R/W	R/W	R/W	R/W	R/W	R/W	R/W
Function	Unsigned Integer															
Default Value	0	0	0	0	0	0	0	0	1	1	1	1	1	0	1	0

VOUT_TRANSITION_RATE (27h)

Definition: Sets the output voltage rate of change during regulation. Changes to this setting require a write to the [“APPLY_SETTINGS \(E7h\)”](#) command before the change takes effect.

Paged or Global: Paged

Data Length in Bytes: 2

Data Format: Direct

Type: R/W

Default Value: 0064h (10mV/μs)

Units: μV/μs

Equation: VOUT_TRANSITION_RATE = (Direct value) x 100

Range: 100μV/μs to 100mV/μs

COMMAND	VOUT_TRANSITION_RATE (27h)															
Format	Direct															
Bit Position	15	14	13	12	11	10	9	8	7	6	5	4	3	2	1	0
Access	R/W	R/W	R/W	R/W	R/W	R/W	R/W	R/W	R/W	R/W	R/W	R/W	R/W	R/W	R/W	R/W
Function	Unsigned Integer															
Default Value	0	0	0	0	0	0	0	0	0	1	1	0	0	1	0	0

VOUT_DROOP (28h)

Definition: Sets the output voltage rate of change during regulation. Changes to this setting require a write to the [“APPLY_SETTINGS \(E7h\)”](#) command before the change takes effect.

Paged or Global: Paged

Data Length in Bytes: 2

Data Format: Direct

Type: R/W

Default Value: 0000h (0μV/A)

Units: μV/A

Equation: VOUT_DROOP = (Direct value) x 10

Range: 0mV/A to 16mV/A

COMMAND	VOUT_DROOP (28h)															
Format	Direct															
Bit Position	15	14	13	12	11	10	9	8	7	6	5	4	3	2	1	0
Access	R/W	R/W	R/W	R/W	R/W	R/W	R/W	R/W	R/W	R/W	R/W	R/W	R/W	R/W	R/W	R/W
Function	Unsigned Integer															
Default Value	0	0	0	0	0	0	0	0	0	0	0	0	0	0	0	0

VOUT_MIN (2Bh)

Definition: Sets the minimum allowed V_{OUT} target regardless of any other commands or combinations.

Paged or Global: Paged

Data Length in Bytes: 2

Data Format: Direct

Type: R/W

Default Value: 0000h (0mV)

Units: mV

Equation: $V_{OUT_MIN} = (\text{Direct value})$

Range: 0V to "[VOUT_MAX \(24h\)](#)"

COMMAND	VOUT_MIN (2Bh)															
Format	Direct															
Bit Position	15	14	13	12	11	10	9	8	7	6	5	4	3	2	1	0
Access	R/W	R/W	R/W	R/W	R/W	R/W	R/W	R/W	R/W	R/W	R/W	R/W	R/W	R/W	R/W	R/W
Function	Unsigned Integer															
Default Value	0	0	0	0	0	0	0	0	0	0	0	0	0	0	0	0

VOUT_OV_FAULT_LIMIT (40h)

Definition: Sets the output overvoltage fault threshold. Changes to this setting require a write to the APPLY_SETTINGS command before the change takes effect.

Paged or Global: Paged

Data Length in Bytes: 2

Data Format: Direct

Type: R/W

Default Value: 076Ch (1900mV)

Units: mV

Equation: $V_{OUT_OV_FAULT_LIMIT} = (\text{Direct value})$

Range: 0V to "[VOUT_MAX \(24h\)](#)"

COMMAND	VOUT_OV_FAULT_LIMIT (40h)															
Format	Direct															
Bit Position	15	14	13	12	11	10	9	8	7	6	5	4	3	2	1	0
Access	R/W	R/W	R/W	R/W	R/W	R/W	R/W	R/W	R/W	R/W	R/W	R/W	R/W	R/W	R/W	R/W
Function	Unsigned Integer															
Default Value	0	0	0	0	0	1	1	1	0	1	1	0	1	1	0	0

VOUT_UV_FAULT_LIMIT (44h)

Definition: Sets the V_{OUT} undervoltage fault threshold. This fault is masked during ramp or when disabled.

Paged or Global: Paged

Data Length in Bytes: 2

Data Format: Direct

Type: R/W

Default Value: 0000h (0mV)

Units: mV

Equation: $V_{OUT_UV_FAULT_LIMIT} = (\text{Direct value})$

Range: 0V to "[VOUT_MAX \(24h\)](#)"

COMMAND	VOUT_UV_FAULT_LIMIT (44h)															
Format	Direct															
Bit Position	15	14	13	12	11	10	9	8	7	6	5	4	3	2	1	0
Access	R/W	R/W	R/W	R/W	R/W	R/W	R/W	R/W	R/W	R/W	R/W	R/W	R/W	R/W	R/W	R/W
Function	Unsigned Integer															
Default Value	0	0	0	0	0	0	0	0	0	0	0	0	0	0	0	0

OT_FAULT_LIMIT (4Fh)

Definition: Sets the power stage over-temperature fault limit.

Paged or Global: Paged

Data Length in Bytes: 2

Data Format: Direct

Type: R/W

Default Value: 007Dh (+125°C)

Units: °C

Equation: $OT_FAULT_LIMIT = (\text{Direct value})$

Range: 0°C to +2000°C

COMMAND	OT_FAULT_LIMIT (4Fh)																
Format	Direct																
Bit Position	15	14	13	12	11	10	9	8	7	6	5	4	3	2	1	0	
Access	R/W	R/W	R/W	R/W	R/W	R/W	R/W	R/W	R/W	R/W	R/W	R/W	R/W	R/W	R/W	R/W	
Function	Two's Complement Integer																
Default Value	0	0	0	0	0	0	0	0	0	0	1	1	1	1	1	0	1

OT_WARN_LIMIT (51h)

Definition: Sets the system over-temperature warn limit. If any measured temperature exceeds this value, the device does the following:

- Sets the TEMPERATURE bit in "[STATUS_BYTE \(78h\)](#)" and "[STATUS_WORD \(79h\)](#)"
- Sets the OT_WARNING bit in "[STATUS_TEMPERATURE \(7Dh\)](#)"
- Sets the SALRT pin
- Sets the TWARN pin

Paged or Global: Paged

Data Length in Bytes: 2

Data Format: Direct

Type: R/W

Default Value: 07D0h (+2000°C)

Units: °C

Equation: OT_WARN_LIMIT = (Direct value)

Range: 0°C to +2000°C

COMMAND	OT_WARN_LIMIT (51h)															
Format	Direct															
Bit Position	15	14	13	12	11	10	9	8	7	6	5	4	3	2	1	0
Access	R/W	R/W	R/W	R/W	R/W	R/W	R/W	R/W	R/W	R/W	R/W	R/W	R/W	R/W	R/W	R/W
Function	Two's Complement Integer															
Default Value	0	0	0	0	0	1	1	1	1	1	0	1	0	0	0	0

VIN_OV_FAULT_LIMIT (55h)

Definition: Sets the V_{IN} overvoltage fault threshold. Changes to this setting require a write to the "[APPLY_SETTINGS \(E7h\)](#)" command before the change takes effect.

Paged or Global: Global

Data Length in Bytes: 2

Data Format: Direct

Type: R/W

Default Value: 36B0h (14000mV)

Units: mV

Equation: VIN_OV_FAULT_LIMIT = (Direct value)

Range: 0mV to 16000mV

COMMAND	VIN_OV_FAULT_LIMIT (55h)															
Format	Direct															
Bit Position	15	14	13	12	11	10	9	8	7	6	5	4	3	2	1	0
Access	R/W	R/W	R/W	R/W	R/W	R/W	R/W	R/W	R/W	R/W	R/W	R/W	R/W	R/W	R/W	R/W
Function	Unsigned Integer															
Default Value	0	0	1	1	0	1	1	0	1	0	1	1	0	0	0	0

VIN_UV_FAULT_LIMIT (59h)

Definition: Sets the V_{IN} undervoltage fault threshold. Also referred to as Undervoltage Lockout (UVLO). Changes to this setting require a write to the [“APPLY_SETTINGS \(E7h\)”](#) command before the change takes effect.

Paged or Global: Global

Data Length in Bytes: 2

Data Format: Direct

Type: R/W

Default Value: 1F40h (8,000mV)

Units: mV

Equation: VIN_UV_FAULT_LIMIT = (Direct value)

Range: 0mV to 16000mV

COMMAND	VIN_UV_FAULT_LIMIT (59h)															
Format	Direct															
Bit Position	15	14	13	12	11	10	9	8	7	6	5	4	3	2	1	0
Access	R/W	R/W	R/W	R/W	R/W	R/W	R/W	R/W	R/W	R/W	R/W	R/W	R/W	R/W	R/W	R/W
Function	Unsigned Integer															
Default Value	0	0	0	1	1	1	1	1	0	1	0	0	0	0	0	0

IIN_OC_FAULT_LIMIT (5Bh)

Definition: Sets the I_{IN} overcurrent fault threshold. Changes to this setting require a write to the [“APPLY_SETTINGS \(E7h\)”](#) command before the change takes effect.

Paged or Global: Global

Data Length in Bytes: 2

Data Format: Direct

Type: R/W

Default Value: 0032h (50A)

Units: A

Equation: IIN_OC_FAULT_LIMIT = (Direct value)

Range: 0A to 50A

COMMAND	IIN_OC_FAULT_LIMIT (5Bh)															
Format	Direct															
Bit Position	15	14	13	12	11	10	9	8	7	6	5	4	3	2	1	0
Access	R/W	R/W	R/W	R/W	R/W	R/W	R/W	R/W	R/W	R/W	R/W	R/W	R/W	R/W	R/W	R/W
Function	Unsigned Integer															
Default Value	0	0	0	0	0	0	0	0	0	0	1	1	0	0	1	0

TON_DELAY (60h)

Definition: Sets the delay time of V_{OUT} during enable.

Paged or Global: Paged

Data Length in Bytes: 2

Data Format: Direct

Type: R/W

Default Value: 0014h (200 μ s)

Units: μ s

Equation: $TON_DELAY = (\text{Direct value}) \times 10$

Range: 200 μ s to 655340 μ s

COMMAND	TON_DELAY (60h)															
Format	Direct															
Bit Position	15	14	13	12	11	10	9	8	7	6	5	4	3	2	1	0
Access	R/W	R/W	R/W	R/W	R/W	R/W	R/W	R/W	R/W	R/W	R/W	R/W	R/W	R/W	R/W	R/W
Function	Unsigned Integer															
Default Value	0	0	0	0	0	0	0	0	0	0	0	1	0	1	0	0

TON_RISE (61h)

Definition: Sets the rise time of V_{OUT} during enable. Changes to this setting require a write to the ["APPLY_SETTINGS \(E7h\)"](#) command before the change takes effect. This function uses the value of V_{OUT} to calculate rise time, so [APPLY_SETTINGS](#) must be sent after any change to the V_{OUT} target for accurate rise time.

Paged or Global: Paged

Data Length in Bytes: 2

Data Format: Direct

Type: R/W

Default Value: 01F4h (500 μ s)

Units: μ s

Equation: $TON_RISE = (\text{Direct value})$

Range: 0 μ s to 10000 μ s

COMMAND	TON_RISE (61h)															
Format	Direct															
Bit Position	15	14	13	12	11	10	9	8	7	6	5	4	3	2	1	0
Access	R/W	R/W	R/W	R/W	R/W	R/W	R/W	R/W	R/W	R/W	R/W	R/W	R/W	R/W	R/W	R/W
Function	Unsigned Integer															
Default Value	0	0	0	0	0	0	0	1	1	1	1	1	0	1	0	0

TOFF_DELAY (64h)

Definition: Sets the delay time of V_{OUT} during disable.

Paged or Global: Paged

Data Length in Bytes: 2

Data Format: Direct

Type: R/W

Default Value: 0000h (0 μ s)

Units: μ s

Equation: TOFF_DELAY = (Direct value) x10

Range: 0 μ s to 10000 μ s

COMMAND	TOFF_DELAY (64h)															
Format	Direct															
Bit Position	15	14	13	12	11	10	9	8	7	6	5	4	3	2	1	0
Access	R/W	R/W	R/W	R/W	R/W	R/W	R/W	R/W	R/W	R/W	R/W	R/W	R/W	R/W	R/W	R/W
Function	Unsigned Integer															
Default Value	0	0	0	0	0	0	0	0	0	0	0	0	0	0	0	0

TOFF_FALL (65h)

Definition: Sets the fall time of V_{OUT} during disable. Changes to this setting require a write to the ["APPLY_SETTINGS \(E7h\)"](#) command before the change takes effect. This function uses the value of V_{OUT} to calculate fall time, so APPLY_SETTINGS must be sent after any change to the V_{OUT} target for accurate fall time.

Paged or Global: Paged

Data Length in Bytes: 2

Data Format: Direct

Type: R/W

Default Value: 01F4h (500 μ s)

Units: μ s

Equation: TOFF_FALL = (Direct value)

Range: 0 to 10000 μ s

COMMAND	TOFF_FALL (65h)															
Format	Direct															
Bit Position	15	14	13	12	11	10	9	8	7	6	5	4	3	2	1	0
Access	R/W	R/W	R/W	R/W	R/W	R/W	R/W	R/W	R/W	R/W	R/W	R/W	R/W	R/W	R/W	R/W
Function	Unsigned Integer															
Default Value	0	0	0	0	0	0	0	1	1	1	1	1	0	1	0	0

STATUS_BYTE (78h)

Definition: Returns a summary of the unit's fault status. Based on the information in this byte, the host can get more information by reading the appropriate status registers. A fault in either output is reported in this register.

Paged or Global: Global

Data Length in Bytes: 2

Data Format: Bit Field

Type: Read Only

Default Value: N/A

COMMAND	STATUS_BYTE (78h)							
Format	Bit Field							
Bit Position	7	6	5	4	3	2	1	0
Access	R	R	R	R	R	R	R	R
Function	See Following Table							

BIT NUMBER	STATUS BIT NAME	MEANING
7	Not Used	Not used.
6	OFF	This bit is asserted if the unit is not providing power to the output, regardless of the reason, including simply not being enabled.
5	VOUT_OV_FAULT	An output overvoltage fault occurred.
4	IOUT_OC_FAULT	An output overcurrent fault occurred.
3	VIN_UV_FAULT	An input undervoltage fault occurred.
2	TEMPERATURE	A temperature fault or warning occurred.
1	CML	A communications, memory, or logic fault occurred.
0	None of the Above	A status change other than those listed above occurred.

STATUS_WORD (79h)

Definition: Returns a summary of the device's fault status. Based on the information in these bytes, the host can get more information by reading the appropriate status registers. A fault in either output is reported in this register. The low byte of STATUS_WORD contains the same information as the "[STATUS_BYTE \(78h\)](#)" command.

Paged or Global: Global

Data Length in Bytes: 2

Data Format: Bit Field

Type: Read Only

Default Value: N/A

COMMAND	STATUS_WORD (79h)															
Format	Bit Field															
Bit Position	15	14	13	12	11	10	9	8	7	6	5	4	3	2	1	0
Access	R	R	R	R	R	R	R	R	R	R	R	R	R	R	R	R
Function	See Following Table															

BIT NUMBER	STATUS BIT NAME	MEANING
15	V _{OUT}	An output voltage fault occurred.
14	I _{OUT}	An output current fault occurred.
13	INPUT	An input voltage fault occurred.
12	MFR_SPECIFIC	A manufacturer specific event occurred.
11	POWER_GOOD #	The POWER_GOOD signal, if present, is negated (Note 8).
10:7	Not Used	Not used.
6	OFF	This bit is asserted if the unit is not providing power to the output, regardless of the reason, including simply not being enabled.
5	V _{OUT_OV_FAULT}	An output overvoltage fault occurred.
4	I _{OUT_OC_FAULT}	An output overcurrent fault occurred.
3	V _{IN_UV_FAULT}	An input undervoltage fault occurred.
2	TEMPERATURE	A temperature fault or warning occurred.
1	CML	A communications, memory, or logic fault occurred.
0	None of the Above	A status change other than those listed above occurred.

NOTE:

8. If the POWER_GOOD# bit is set, this status indicates that the POWER_GOOD signal, if present, is signaling that the output power is not good.

STATUS_VOUT (7Ah)**Definition:** Returns a summary of output voltage faults.**Paged or Global:** Paged**Data Length in Bytes:** 1**Data Format:** Bit Field**Type:** Read Only**Default Value:** N/A

COMMAND	STATUS_VOUT (7Ah)							
Format	Bit Field							
Bit Position	7	6	5	4	3	2	1	0
Access	R	R	R	R	R	R	R	R
Function	See Following Table							

BIT NUMBER	STATUS BIT NAME	MEANING
7	VOUT_OV_FAULT	Indicates an output overvoltage fault.
6:5	Not Used	Not used.
4	VOUT_UV_FAULT	Indicates an output undervoltage fault.
3	VOUT_MAX Warning	Indicates an output voltage maximum warning.
2:0	Not Used	Not used.

STATUS_IOUT (7Bh)**Definition:** Returns a summary of output current faults.**Paged or Global:** Paged**Data Length in Bytes:** 1**Data Format:** Bit Field**Type:** Read Only**Default Value:** N/A

COMMAND	STATUS_IOUT (7Bh)							
Format	Bit Field							
Bit Position	7	6	5	4	3	2	1	0
Access	R	R	R	R	R	R	R	R
Function	See Following Table							

BIT NUMBER	MEANING
7	An output overcurrent fault has occurred.
6	An output overcurrent and undervoltage fault has occurred.
5:4	Not used.
3	A current share fault has occurred.
2:0	Not used.

STATUS_INPUT (7Ch)**Definition:** Returns a summary of input voltage faults.**Paged or Global:** Global**Data Length in Bytes:** 1**Data Format:** Bit Field**Type:** Read Only**Default Value:** N/A

COMMAND	STATUS_INPUT (7Ch)							
Format	Bit Field							
Bit Position	7	6	5	4	3	2	1	0
Access	R	R	R	R	R	R	R	R
Function	See Following Table							

BIT NUMBER	MEANING
7	An input overvoltage fault occurred.
6:5	Not used.
4	An input undervoltage fault occurred. This fault is initially masked until V_{IN} exceeds the UV threshold.
3	Not used.
2	An input overcurrent fault occurred.
1:0	Not used.

STATUS_TEMPERATURE (7Dh)**Definition:** Returns a summary of temperature related faults.**Paged or Global:** Global**Data Length in Bytes:** 1**Data Format:** Bit Field**Type:** Read Only**Default Value:** N/A

COMMAND	STATUS_TEMPERATURE (7Dh)							
Format	Bit Field							
Bit Position	7	6	5	4	3	2	1	0
Access	R	R	R	R	R	R	R	R
Function	See Following Table							

BIT NUMBER	MEANING
7	An over-temperature fault occurred.
6	An over-temperature warning occurred.
5	Not used.
4	An under-temperature fault occurred.
3:0	Not used.

STATUS_CML (7Eh)

Definition: Returns a summary of any communications, logic, and/or memory errors.

Paged or Global: Global

Data Length in Bytes: 1

Data Format: Bit Field

Type: Read Only

Default Value: N/A

COMMAND	STATUS_CML (7Eh)							
Format	Bit Field							
Bit Position	7	6	5	4	3	2	1	0
Access	R	R	R	R	R	R	R	R
Function	See Following Table							

BIT NUMBER	MEANING
7	An invalid or unsupported PMBus Command was received.
6	The PMBus command was sent with invalid or unsupported data.
5	A packet error was detected in the PMBus command.
4	Memory fault detected.
3	Processor fault detected.
2	Not used.
1	A communication fault other than the ones listed in this table occurred.
0	A memory or logic fault not listed above was detected.

STATUS_MFR_SPECIFIC (80h)

Definition: Returns the status of specific information detailed as follows.

Paged or Global: Global

Data Length in Bytes: 1

Data Format: Bit Field

Type: Read Only

Default Value: N/A

COMMAND	STATUS_MFR_SPECIFIC (80h)							
Format	Bit Field							
Bit Position	7	6	5	4	3	2	1	0
Access	R	R	R	R	R	R	R	R
Function	See Following Table							

BIT	MEANING
7:2	Not used
1	OTP NVM memory is full.
0	Not used

READ_VIN (88h)**Definition:** Returns the input voltage reading.**Paged or Global:** Global**Data Length in Bytes:** 2**Data Format:** Direct**Type:** Read Only**Default Value:** N/A**Units:** mV**Equation:** READ_VIN = (Direct value)

COMMAND	READ_VIN (88h)															
Format	Direct															
Bit Position	15	14	13	12	11	10	9	8	7	6	5	4	3	2	1	0
Access	R	R	R	R	R	R	R	R	R	R	R	R	R	R	R	R
Function	Two's Complement Integer															

READ_IIN (89h)**Definition:** Returns the input current reading.**Paged or Global:** Global**Data Length in Bytes:** 2**Data Format:** Direct**Type:** Read Only**Default Value:** N/A**Units:** A**Equation:** READ_IIN = (Direct value)/100

COMMAND	READ_IIN (89h)															
Format	Direct															
Bit Position	15	14	13	12	11	10	9	8	7	6	5	4	3	2	1	0
Access	R	R	R	R	R	R	R	R	R	R	R	R	R	R	R	R
Function	Two's Complement Integer															

READ_VOUT (8Bh)**Definition:** Returns the output voltage reading.**Paged or Global:** Paged**Data Length in Bytes:** 2**Data Format:** Direct**Type:** Read Only**Default Value:** N/A**Units:** mV**Equation:** READ_VOUT = (Direct value)

COMMAND	READ_VOUT (8Bh)															
Format	Direct															
Bit Position	15	14	13	12	11	10	9	8	7	6	5	4	3	2	1	0
Access	R	R	R	R	R	R	R	R	R	R	R	R	R	R	R	R
Function	Two's Complement Integer															

READ_IOUT (8Ch)**Definition:** Returns the output current reading.**Paged or Global:** Paged**Data Length in Bytes:** 2**Data Format:** Direct**Type:** Read Only**Default Value:** N/A**Units:** A**Equation:** READ_IOUT = (Direct value)/10

COMMAND	READ_IOUT (8Ch)															
Format	Direct															
Bit Position	15	14	13	12	11	10	9	8	7	6	5	4	3	2	1	0
Access	R	R	R	R	R	R	R	R	R	R	R	R	R	R	R	R
Function	Two's Complement Integer															

READ_TEMPERATURE_1 (8Dh)**Definition:** Returns the temperature reading of the power stage.**Paged or Global:** Paged**Data Length in Bytes:** 2**Data Format:** Direct**Type:** Read Only**Default Value:** N/A**Units:** °C**Equation:** READ_TEMPERATURE_1 = (Direct value)

COMMAND	READ_TEMPERATURE_1 (8Dh)															
Format	Direct															
Bit Position	15	14	13	12	11	10	9	8	7	6	5	4	3	2	1	0
Access	R	R	R	R	R	R	R	R	R	R	R	R	R	R	R	R
Function	Two's Complement Integer															

READ_TEMPERATURE_2 (8Eh)**Definition:** Returns the temperature reading from a remote diode connected to TMON0 when configured for diode sensing.**Paged or Global:** Global**Data Length in Bytes:** 2**Data Format:** Direct**Type:** Read Only**Default Value:** N/A**Units:** °C**Equation:** READ_TEMPERATURE_2 = (Direct value)

COMMAND	READ_TEMPERATURE_2 (8Eh)															
Format	Direct															
Bit Position	15	14	13	12	11	10	9	8	7	6	5	4	3	2	1	0
Access	R	R	R	R	R	R	R	R	R	R	R	R	R	R	R	R
Function	Two's Complement Integer															

READ_TEMPERATURE_3 (8Fh)

Definition: Returns the temperature reading from a remote diode connected to TMON1 when configured for diode sensing.

Paged or Global: Global

Data Length in Bytes: 2

Data Format: Direct

Type: Read Only

Default Value: N/A

Units: °C

Equation: READ_TEMPERATURE_3 = (Direct value)

COMMAND	READ_TEMPERATURE_3 (8Fh)															
Format	Direct															
Bit Position	15	14	13	12	11	10	9	8	7	6	5	4	3	2	1	0
Access	R	R	R	R	R	R	R	R	R	R	R	R	R	R	R	R
Function	Two's Complement Integer															

READ_POUT (96h)

Definition: Returns the output power.

Paged or Global: Paged

Data Length in Bytes: 2

Data Format: Direct

Type: Read Only

Default Value: N/A

Units: W

Equation: READ_POUT = (Direct value)

COMMAND	READ_POUT (96h)															
Format	Direct															
Bit Position	15	14	13	12	11	10	9	8	7	6	5	4	3	2	1	0
Access	R	R	R	R	R	R	R	R	R	R	R	R	R	R	R	R
Function	Two's Complement Integer															

READ_PIN (97h)

Definition: Returns the input power.

Paged or Global: Global

Data Length in Bytes: 2

Data Format: Direct

Type: Read Only

Default Value: N/A

Units: W

Equation: READ_PIN = (Direct value)

COMMAND	READ_PIN (97h)															
Format	Direct															
Bit Position	15	14	13	12	11	10	9	8	7	6	5	4	3	2	1	0
Access	R	R	R	R	R	R	R	R	R	R	R	R	R	R	R	R
Function	Two's Complement Integer															

PMBUS_REVISION (98h)

Definition: Returns the revision of the PMBus Specification to which the device is compliant.

Data Length in Bytes: 1

Data Format: Bit Field

Type: Read Only

Default Value: 33h (Part 1 Revision 1.3, Part 2 Revision 1.3)

COMMAND	PMBUS_REVISION (98h)							
Format	Bit Field							
Bit Position	7	6	5	4	3	2	1	0
Access	R	R	R	R	R	R	R	R
Function	See Following Table							
Default Value	0	0	1	1	0	0	1	1

BITS 7:4	PART 1 REVISION	BITS 3:0	PART 2 REVISION
0000	1.0	0000	1.0
0001	1.1	0001	1.1
0010	1.2	0010	1.2
0011	1.3	0011	1.3

IC_DEVICE_ID (ADh)

Definition: Returns device identification information.

Paged or Global: Global

Data Length in Bytes: 4

Data Format: Bit Field

Type: Block Read

Default Value: 49D22800h

COMMAND	IC_DEVICE_ID (ADh)			
Format	Block Read			
Byte Position	3	2	1	0
Function	MFR Code	ID High Byte	ID Low Byte	Reserved
Default Value	49h	D2h	28h	00h

IC_DEVICE_REV (AEh)

Definition: Returns device revision information.

Paged or Global: Global

Data Length in Bytes: 4

Data Format: Bit Field

Type: Block Read

Default Value: N/A

COMMAND	IC_DEVICE_REV (AEh)			
Format	Block Read			
Bit Position	23:16	15:8	7:4	3:0
Function	Firmware Revision	Factory Configuration	Chip Foundry Site	IC Revision
Default Value	N/A	N/A	N/A	N/A

APPLY_SETTINGS (E7h)

Definition: Instructs the controller to use new PMBus parameters. Send 01h to this command after making one or more changes to certain PMBus threshold commands that require rescaling of operational values. The commands that require this are:

- [“VOUT_TRANSITION_RATE \(27h\)”](#)
- [“VOUT_DROOP \(28h\)”](#)
- [“VOUT_OV_FAULT_LIMIT \(40h\)”](#)
- [“VIN_OV_FAULT_LIMIT \(55h\)”](#)
- [“VIN_UV_FAULT_LIMIT \(59h\)”](#)
- [“IIN_OC_FAULT_LIMIT \(5Bh\)”](#)
- [“TON_RISE \(61h\)”](#)
- [“TOFF_FALL \(65h\)”](#)

Paged or Global: Global

Data Length in Bytes: 2

Data Format: Bit Field

Type: Write Only

Default Value: 01h

RESTORE_CONFIG (F2h)

Definition: Identifies the configuration to be restored from NVM and loads the store's settings into the device's active memory. This command must only be sent while the outputs are disabled.

Paged or Global: Global

Data Length in Bytes: 1

Data Format: BIT

Type: Write Only

Default Value: N/A

COMMAND	RESTORE_CONFIG (F2h)							
Format	Bit Field							
Bit Position	7	6	5	4	3	2	1	0
Access	R/W	R/W	R/W	R/W	R/W	R/W	R/W	R/W
Function	See Following Table							
Default Value	N/A	N/A	N/A	N/A	N/A	N/A	N/A	N/A

BIT NUMBER	STATUS BIT NAME	MEANING
7:4	Reserved	Reserved
3:0	CONFIG	Selected configuration to restore

Revision History

The revision history provided is for informational purposes only and is believed to be accurate, but not warranted. Please visit our website to make sure you have the latest revision.

DATE	REVISION	CHANGE
Jul 12, 2019	FN8748.2	<p>On page 3, updated Ordering Information table by adding tape and reel parts, Tape and Reel column, and updating Note 1.</p> <p>On page 4, changed the suggested typical resistor divider value for the VINSSEN (pin 22) from 402k to 40.2k.</p> <p>On page 13, added "Fast Phase Add Function" heading.</p> <p>Removed About Intersil section.</p> <p>Updated Renesas disclaimer.</p>
Jun 26, 2017	FN8748.1	<p>Applied new header and footer.</p> <p>Updated "READ_PIN (97h)" on page 43, changed "Paged" to "Global".</p> <p>Updated the "Package Outline Drawing" section.</p> <p>Updated Figure 5 on page 9.</p> <p>Updated "Enable (EN0 and EN1) Input High Level" on page 10. Removed the typical value and added a minimum value of 2.55V.</p> <p>Added an entry for "Enable (EN0 and EN1) Input Low Level" on page 10 with a maximum of 0.8V.</p> <p>Added an entry for "SCL, SDA Input High Level" on page 11 with a minimum value of 1.55V.</p> <p>Removed the entry for "SCL, SDA Input High/Low Threshold".</p> <p>Added an entry for "SCL, SDA Input Low Level" on page 11 with a maximum value of 0.8V.</p> <p>Changed "STATUS_CML" on page 22, bit 1 from "PMBus command tried to write to a read only or protected command, or a communication fault other than the ones listed in this table has occurred" to "A communication fault other than the ones listed in this table has occurred".</p> <p>Changed "Two's Complement Integer" to "Unsigned Integer" for the following PMBus commands:</p> <ul style="list-style-type: none"> - VOUT_COMMAND - VOUT_MAX - VOUT_MARGIN_HIGH - VOUT_MARGIN_LOW - VOUT_TRANSITION_RATE - VOUT_DROOP - VOUT_MIN - VOUT_OV_FAULT_LIMIT - VOUT_UV_FAULT_LIMIT - VIN_OV_FAULT_LIMIT - VIN_UV_FAULT_LIMIT - IIN_OC_FAULT_LIMIT - TON_DELAY - TON_RISE - TOFF_DELAY - TOFF_FALL
Sep 28, 2016	FN8748.0	Initial release

Package Outline Drawing

L48.6x6B

48 LEAD QUAD FLAT NO-LEAD PLASTIC PACKAGE

Rev 0, 9/09

For the most recent package outline drawing, see [L48.6x6B](#).

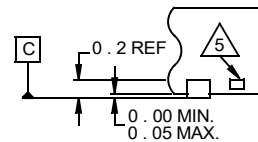
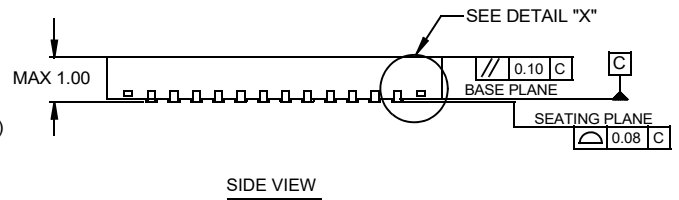
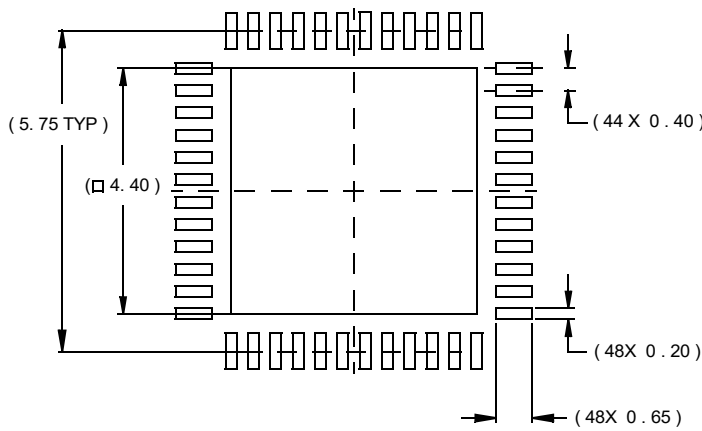
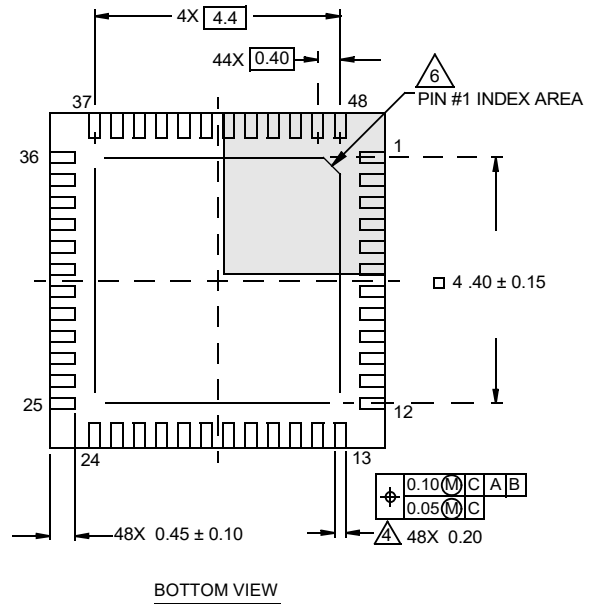
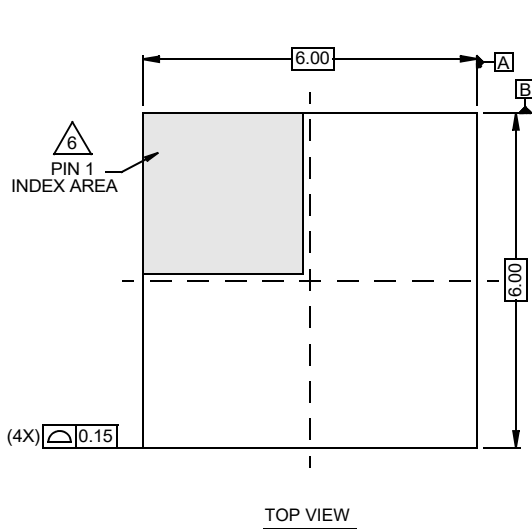

NOTES:

1. Dimensions are in millimeters.
Dimensions in () for Reference Only.
2. Dimensioning and tolerancing conform to AMSE Y14.5m-1994.
3. Unless otherwise specified, tolerance : Decimal ± 0.05
4. Dimension applies to the metallized terminal and is measured between 0.15mm and 0.30mm from the terminal tip.
5. Tiebar shown (if present) is a non-functional feature.
6. The configuration of the pin #1 identifier is optional, but must be located within the zone indicated. The pin #1 identifier may be either a mold or mark feature.

Notice

1. Descriptions of circuits, software and other related information in this document are provided only to illustrate the operation of semiconductor products and application examples. You are fully responsible for the incorporation or any other use of the circuits, software, and information in the design of your product or system. Renesas Electronics disclaims any and all liability for any losses and damages incurred by you or third parties arising from the use of these circuits, software, or information.
 2. Renesas Electronics hereby expressly disclaims any warranties against and liability for infringement or any other claims involving patents, copyrights, or other intellectual property rights of third parties, by or arising from the use of Renesas Electronics products or technical information described in this document, including but not limited to, the product data, drawings, charts, programs, algorithms, and application examples.
 3. No license, express, implied or otherwise, is granted hereby under any patents, copyrights or other intellectual property rights of Renesas Electronics or others.
 4. You shall not alter, modify, copy, or reverse engineer any Renesas Electronics product, whether in whole or in part. Renesas Electronics disclaims any and all liability for any losses or damages incurred by you or third parties arising from such alteration, modification, copying or reverse engineering.
 5. Renesas Electronics products are classified according to the following two quality grades: "Standard" and "High Quality". The intended applications for each Renesas Electronics product depends on the product's quality grade, as indicated below.
 - "Standard": Computers; office equipment; communications equipment; test and measurement equipment; audio and visual equipment; home electronic appliances; machine tools; personal electronic equipment; industrial robots; etc.
 - "High Quality": Transportation equipment (automobiles, trains, ships, etc.); traffic control (traffic lights); large-scale communication equipment; key financial terminal systems; safety control equipment; etc.Unless expressly designated as a high reliability product or a product for harsh environments in a Renesas Electronics data sheet or other Renesas Electronics document, Renesas Electronics products are not intended or authorized for use in products or systems that may pose a direct threat to human life or bodily injury (artificial life support devices or systems; surgical implantations; etc.), or may cause serious property damage (space system; undersea repeaters; nuclear power control systems; aircraft control systems; key plant systems; military equipment; etc.). Renesas Electronics disclaims any and all liability for any damages or losses incurred by you or any third parties arising from the use of any Renesas Electronics product that is inconsistent with any Renesas Electronics data sheet, user's manual or other Renesas Electronics document.
 6. When using Renesas Electronics products, refer to the latest product information (data sheets, user's manuals, application notes, "General Notes for Handling and Using Semiconductor Devices" in the reliability handbook, etc.), and ensure that usage conditions are within the ranges specified by Renesas Electronics with respect to maximum ratings, operating power supply voltage range, heat dissipation characteristics, installation, etc. Renesas Electronics disclaims any and all liability for any malfunctions, failure or accident arising out of the use of Renesas Electronics products outside of such specified ranges.
 7. Although Renesas Electronics endeavors to improve the quality and reliability of Renesas Electronics products, semiconductor products have specific characteristics, such as the occurrence of failure at a certain rate and malfunctions under certain use conditions. Unless designated as a high reliability product or a product for harsh environments in a Renesas Electronics data sheet or other Renesas Electronics document, Renesas Electronics products are not subject to radiation resistance design. You are responsible for implementing safety measures to guard against the possibility of bodily injury, injury or damage caused by fire, and/or danger to the public in the event of a failure or malfunction of Renesas Electronics products, such as safety design for hardware and software, including but not limited to redundancy, fire control and malfunction prevention, appropriate treatment for aging degradation or any other appropriate measures. Because the evaluation of microcomputer software alone is very difficult and impractical, you are responsible for evaluating the safety of the final products or systems manufactured by you.
 8. Please contact a Renesas Electronics sales office for details as to environmental matters such as the environmental compatibility of each Renesas Electronics product. You are responsible for carefully and sufficiently investigating applicable laws and regulations that regulate the inclusion or use of controlled substances, including without limitation, the EU RoHS Directive, and using Renesas Electronics products in compliance with all these applicable laws and regulations. Renesas Electronics disclaims any and all liability for damages or losses occurring as a result of your noncompliance with applicable laws and regulations.
 9. Renesas Electronics products and technologies shall not be used for or incorporated into any products or systems whose manufacture, use, or sale is prohibited under any applicable domestic or foreign laws or regulations. You shall comply with any applicable export control laws and regulations promulgated and administered by the governments of any countries asserting jurisdiction over the parties or transactions.
 10. It is the responsibility of the buyer or distributor of Renesas Electronics products, or any other party who distributes, disposes of, or otherwise sells or transfers the product to a third party, to notify such third party in advance of the contents and conditions set forth in this document.
 11. This document shall not be reprinted, reproduced or duplicated in any form, in whole or in part, without prior written consent of Renesas Electronics.
 12. Please contact a Renesas Electronics sales office if you have any questions regarding the information contained in this document or Renesas Electronics products.
- (Note1) "Renesas Electronics" as used in this document means Renesas Electronics Corporation and also includes its directly or indirectly controlled subsidiaries.
- (Note2) "Renesas Electronics product(s)" means any product developed or manufactured by or for Renesas Electronics.

(Rev.4.0-1 November 2017)

Corporate Headquarters

TOYOSU FORESIA, 3-2-24 Toyosu,
Koto-ku, Tokyo 135-0061, Japan
www.renesas.com

Contact Information

For further information on a product, technology, the most up-to-date version of a document, or your nearest sales office, please visit:
www.renesas.com/contact/

Trademarks

Renesas and the Renesas logo are trademarks of Renesas Electronics Corporation. All trademarks and registered trademarks are the property of their respective owners.