**Comparative analysis of driving approach and performance
of 1.2 kV SiC MOSFETs, Si IGBTs, and normally-off SiC JFETs**

By Bettina Rubino, Giuseppe Catalisano, Luigi Abbatelli and Simone Buonomo

Abstract

This article presents the results of a comparative analysis between a 1.2 kV SiC MOSFET, a 1.2 kV 25 A Si IGBT and a 1.2 kV normally-off SiC JFET on a 5 kW demonstrator at different power levels and different f_{sw} values. Beyond the evaluation of their electrical and thermal performances, special focus is given to the driving aspect. It will be shown that the SiC MOSFET achieves higher efficiency than the JFET and IGBT at all power levels and all f_{sw} ranges chosen for the converter, requiring at the same time the simplest driving approach.

Contents

- 1 Introduction 3**
- 2 What are the alternatives in the 1200 V range? 5**
 - 2.1 SiC MOSFET vs silicon 1.2 kV IGBT: static comparison 5
 - 2.2 SiC MOSFET vs silicon 1.2 kV IGBT: dynamic comparison 6
 - 2.3 1200 V SiC MOSFET vs normally-off 1.2 kV SiC JFET: driving differences 6
- 3 SiC MOSFET (and others) on 5 kW DC-DC boost 9**
- 4 Conclusion 13**
- 5 Literature 13**
- 6 Revision history 14**

1 Introduction

Power electronics require higher and higher efficiency levels, as well as cost and size reduction. In the 1.2 kV device range, SiC is becoming an excellent alternative to the currently used silicon technologies. They guarantee $R_{on} \cdot A$ values far lower than the latest MOSFET technology for similar BV, while moving the operative frequency limit well beyond the one achievable by the newest IGBTs on the market.

In this analysis, the device SCT30N120, a 1.2 kV 80 mΩ SiC MOSFET, has been compared with a 1.2 kV 80 mΩ normally-off SiC JFET and with a 1.2 kV, 25 A silicon IGBT in trench and field stop technology (see the main electrical characteristics in [Table 1](#)) on a real application. A very simple 5 kW BOOST converter in CCM, open loop has been constructed (see [Figure 1](#)).

Table 1. Main electrical characteristics of the three compared devices

Compared devices, package	BV, I	Typ R_{on}/V_{cesat}
SiC MOSFET, HiP247	1.2 kV, 34 A @ 100°C	80 mΩ @ 20 V, 25°C - 100 mΩ @ 20 V, 200°C
Normally-off SiC JFET TO-247	1.2 kV, 12A @ 175°C	80 mΩ @ 3 V, 25°C - 200 mΩ @ 3 V, 175°C
SI IGBT TO-247	1.2 kV, 25A @ 100°C	2.1 V @ 15 V, 25 A (84 mΩ equiv. @ 15 V, 25 A) 2.7 V @ 15 V, 25 A, 175°C

During experimental testing, both case temperatures and converter efficiency were measured at three different output power levels: 2 kW, 4 kW, and 5 kW, between 25 kHz and 125 kHz. Since SiC MOS-FET and JFET (OFF) are so different in terms of technology and driving requirements, ([1],[2]), two different driving networks have been implemented. As far as the IGBT is concerned, its driving stage was similar to that of the SiC MOSFET, except for the +15 V required to fully saturate the channel, rather than +20 V needed by the SiC MOSFET.

Final results of the comparison, in terms of efficiency and case temperature measured on the switches, demonstrate that the Si IGBT reached its practical limit at a frequency value between 25 kHz and 50 kHz, due to its high power dissipation. The SiC MOSFET has better performance than the SiC JFET (OFF) at any power level of the converter, and its advantage increases as power increases. Another aspect, and one which should not be neglected by system designers, is the simplicity of driving network needed by the SiC MOSFET, as opposed to the extreme complexity of the driving stage required by the SiC JFET (OFF).

Figure 1. 5 kW DC-DC boost demonstrator

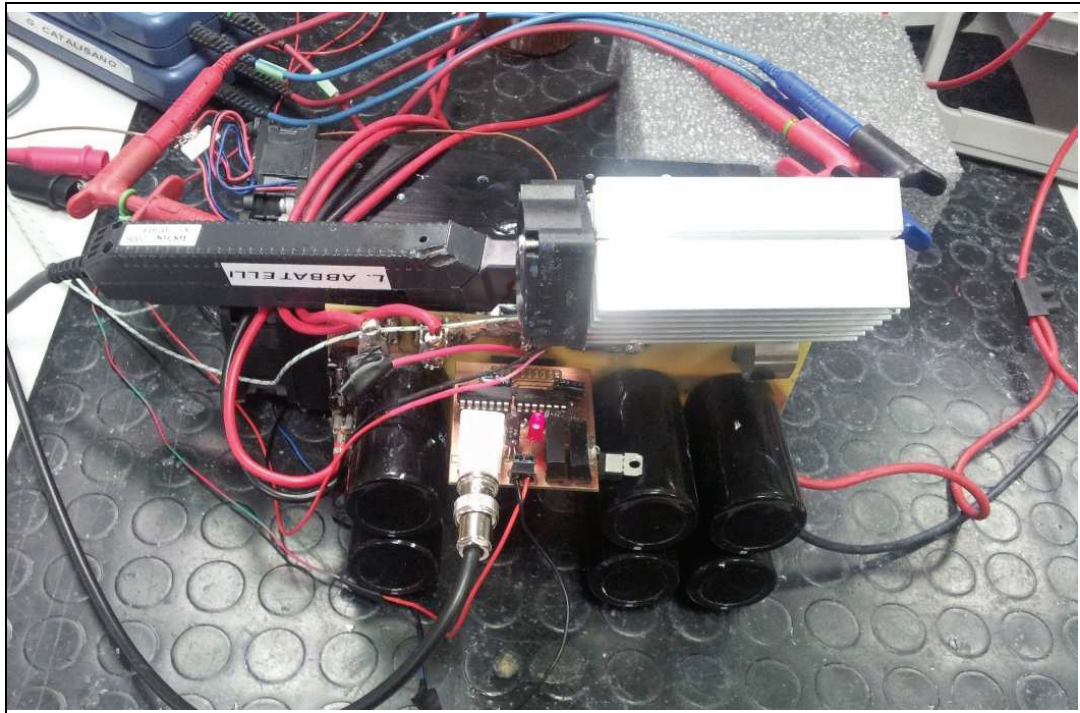

Table 2. DC-DC boost specifications

Topology, f_{sw} range	V_{IN} DC	V_{OUT} DC	D	Main switch	Boost diodes
DC-DC boost in CCM open loop, (25kHz, 125kHz)	600V	800V	$\approx 25\%$	One single switch on 0.3 °C/W heatsink (with fan)	ST 1.2 kV, 6A SiC diodes (two in parallel on heatsink)

2 What are the alternatives in the 1200 V range?

2.1 SiC MOSFET vs silicon 1.2 kV IGBT: static comparison

It is quite interesting to look at the SiC alternatives in the 1200 V range. Silicon MOSFETs are still out of this race. Despite outperforming super junction technology, whose key features in terms of low specific R_{on} and promising dynamic performance has been extended as high as 1200 V, there are no silicon MOSFETs today covering this very high voltage range that are capable to guaranteeing $R_{on} \cdot A$ values comparable to those offered by SiC products of the same BV. The specific R_{on} , one order of magnitude higher than that of SiC switches, leads to significantly higher gate charge values. As a consequence, they exhibit still higher driving efforts and overall dynamic performances worse than those of their SiC alternatives of the same BV.

The most recent advances in IGBT technology offer quite competitive products, featuring much lower switching losses than previous IGBTs in punch-through technology, and at the same time, reduced chip sizes. Today, the lowest specific R_{on} is achieved by the trench gate field stop version, with an $R_{on} \cdot A$ of around 20. This value of specific R_{on} can be comparable to those achieved by the SiC products, but a more detailed discussion under static and dynamic performance comparison should be undertaken. *Figure 2* shows the output characteristics of the 1200 V Si IGBT and SiC MOSFET under comparison in this work. SiC MOSFET static losses are lower than those of the Si IGBT under 25 A at 25 °C.

As the temperature increases, the area of advantage of the SiC MOSFET moves up to 35 A (@175 °C). In the 5 kW DC-DC converter developed for this analysis, the input current flowing through the main switch during the T_{on} time is always lower than 25 A (this is the minimum value of the cross-point between the two characteristics as the operating temperatures of the devices are surely higher than 25 °C), so, the SiC MOSFET static losses are lower than those of the IGBT. It must be pointed out that the static loss contribution over the total power loss computation is not crucial, as it is with the dynamic one, due to the quite low duty cycle of the DC-DC boost ($D \approx 25\%$) under the conditions specified in *Table 2*. In the following paragraphs however, it will be demonstrated why the SiC MOSFET is also preferred over the IGBT under the dynamic aspect if the switching frequency is higher than 25 kHz.

Figure 2. Output characteristics of Si IGBT and SiC MOSFET @25 °C and 175 °C

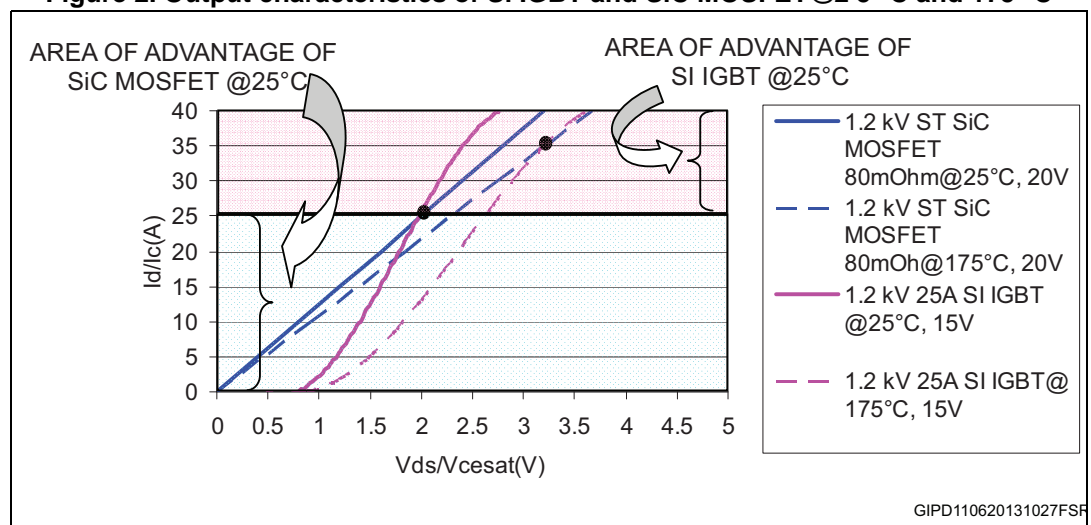

2.2 SiC MOSFET vs silicon 1.2 kV IGBT: dynamic comparison

The 1200 V Si IGBT and the 1200 V SiC MOSFET have been tested in the DC-DC boost prototype at different power levels and several f_{sw} values, ranging from 25 kHz up to 125 kHz.

Figure 3. Si IGBT (left) and SiC MOSFET (right) E_{off} @ $I_c=12.5A, V_{ce}/ds=800V, R_{goff}=2.2\Omega, V_{gsoff}=4V$

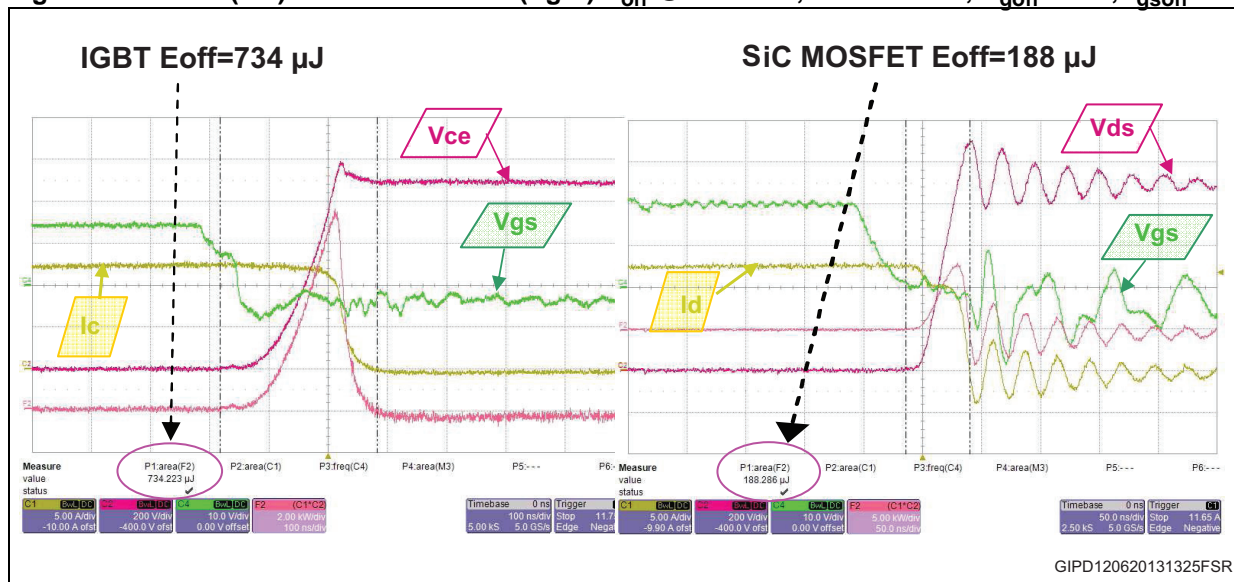

The minimum value of 25 kHz has been chosen to allow the comparison with the IGBT. A single high current/high speed gate driver was used for both SiC MOSFET and Si IGBT.

Figure 3 shows the experimental evidence of the advantage offered by the SiC MOSFET if compared to the Si IGBT. The waveforms refer to the same operating conditions in the DC-DC boost CCM: $P_{in}=5$ kW, $V_{in}=600$ V, $V_{out}=800$ V, $R_{goff}=2.2\Omega$, $V_{gsoff}=-4$ V; current at turn off is around $I_d/c=12.5$ A for both switches. The Si IGBT E_{off} value is almost four times higher than the SiC MOSFET E_{off} , leading to a -75% dynamic loss just taking into consideration the turn off contribution over the total power loss calculation. In this case, both IGBT and SiC MOSFET have been turned on by using the same clamp diodes in the boost converter (two 1200 V, 6 A SiC diodes in parallel), so the contribution of the E_{on} over the total power computation was similar for both switches.

2.3 1200 V SiC MOSFET vs normally-off 1.2 kV SiC JFET: driving differences

The SiC MOSFET is not the only technology to be proposed in the 1200 V range: JFET structures, both normally-on and normally-off have been promoted as promising and high-performing by their respective manufacturers. Despite some advantages in terms of R_{on}^*A , the driving approach is much more complex than that adopted for the SiC MOSFET. This work is focused on the normally-off JFET structure, which has been compared, for driving and dynamic aspects, with the SiC MOSFET. Two dedicated driving networks have been implemented and realized to drive the SiC MOSFET (see Figure 4) and the SiC JFET (OFF) (see Figure 5).

Each driving block has been constructed on a different PCB and connected to the same power board very close to the gate of the main power switch of the boost. This modular approach also allowed all the physical distances in the power board to be kept unchanged when comparing the effects of the parasitic components with different devices. The SiC MOSFET requires +20 V of positive voltage applied to the gate to reach the best $R_{DS(on)}$: no other special feature is required in terms of driving, and this makes the SiC MOSFET extremely easy to use also as silicon switches. A slight negative voltage at turn off (-4 V) was applied to the MOSFET gate, even if this was not mandatory. The same driving board was adopted for the IGBT, just reducing the positive voltage V_{cc} of the driver and the optocoupler down to +15 V.

The driving network built for the normally-off SiC JFET is more complex. A double channel driver was used to build the special shape of gate charge required to properly drive the device [1]. Channel "B" provides the short pulse voltage signal (≈ 200 ns), and through a low gate resistor value, injects the high peak gate charge to quickly turn on the device. Channel "A" provides the voltage signal capable of sustaining the steady state condition with a low gate current value and also turns off the switch. Extreme care was required to guarantee that the two output driver channels were synchronous to each other, as even a minimal time mismatch between them could cause a serious decrease in the JFET's dynamic performance. A higher negative voltage of -10 V was applied to turn off the JFET to minimize the possibility of undesired turn-on due to the JFET's low threshold voltage value. Despite this, some undesired oscillations and noise in the gate voltage signal were observed.

Figure 4. SiC MOSFET driving network used in the DC-DC boost

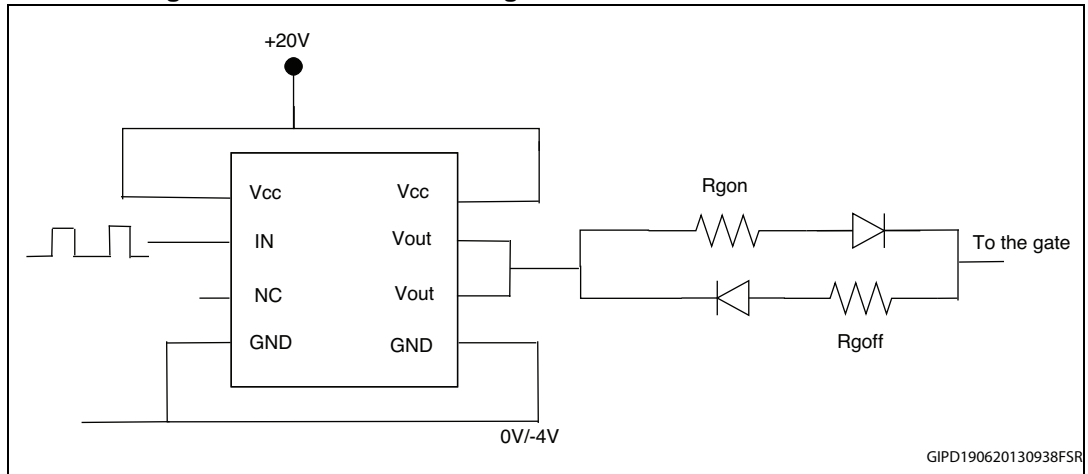
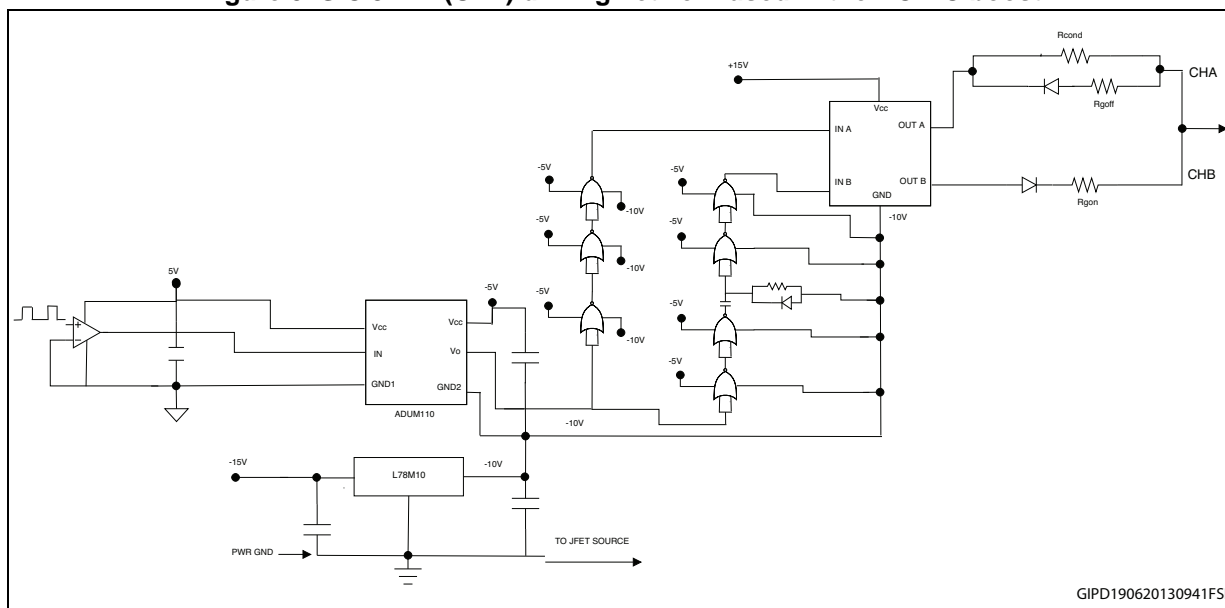

Figure 5. SiC JFET (OFF) driving network used in the DC-DC boost



3 SiC MOSFET (and others) on 5 kW DC-DC boost

A SiC MOSFET has been widely tested on the DC-DC boost converter at three power levels and in a range of f_{sw} between 25 kHz and 125 kHz.

Table 3. Driving of the three compared devices on DC-DC boost

Compared devices	Driving	Total power loss dissipation (W) ($P_{COND} + P_{SW}$) @4kW,25kHz
SiC MOSFET	RGON=RGOFF=2.2Ω, VGSOFF= -4V	0.24+6.1=6.4
SI IGBT		1.1+17.5=18.6
Normally-off SiC JFET	RGON=5.6Ω, RGOFF=4.7Ω, VGSOFF= -10V	1.2+7.7=8.9

A first experimental evaluation was performed at 25 kHz on all the devices listed in [Table 3](#). As evident from [Figure 6](#) and [Figure 7](#), the advantage of the SiC MOSFET over the JFET increases as power level increases, for two reasons: normally-off SiC JFET exhibits higher switching losses, and static losses which dramatically worsen as junction temperature increases. As a reference, [Table 3](#) reports the conduction and the switching losses calculated at $P_o = 4$ kW, $f_{sw} = 25$ kHz for both switches.

The Si IGBT is still a good choice at 25 kHz, but the efficiency values measured on the converter are significantly lower ($\approx 0.3\%$ lower efficiency at 4 kW, see [Figure 6](#)) than the SiC MOSFET efficiency under the same output power conditions: this is caused by the IGBT switching losses, which are significantly higher than the SiC MOSFET ones, and this is confirmed by the total loss calculation reported in [Table 3](#). At $f_{sw} = 50$ kHz, the Si IGBT has already reached its operating limit, as it is not able to safely work at 5 kW. The efficiency gap with the SiC MOSFET has grown (see [Figure 8](#)), and the case temperature at full load widely exceeds $T_{cmax} = 90$ °C @ $T_{amb} = 25$ °C (see [Figure 9](#)): this case temperature has been considered the maximum temperature allowed for “safe” IGBT operation, and the board was stopped after few minutes.

On the contrary, the SiC MOSFET is able to work with excellent results (see [Figure 10](#) and [Figure 11](#)) up to 125 kHz, as also evident from the waveforms reported in [Figure 12](#) and [Figure 13](#).

Figure 6. Efficiency values measured in the DC-DC boost @ 25 kHz

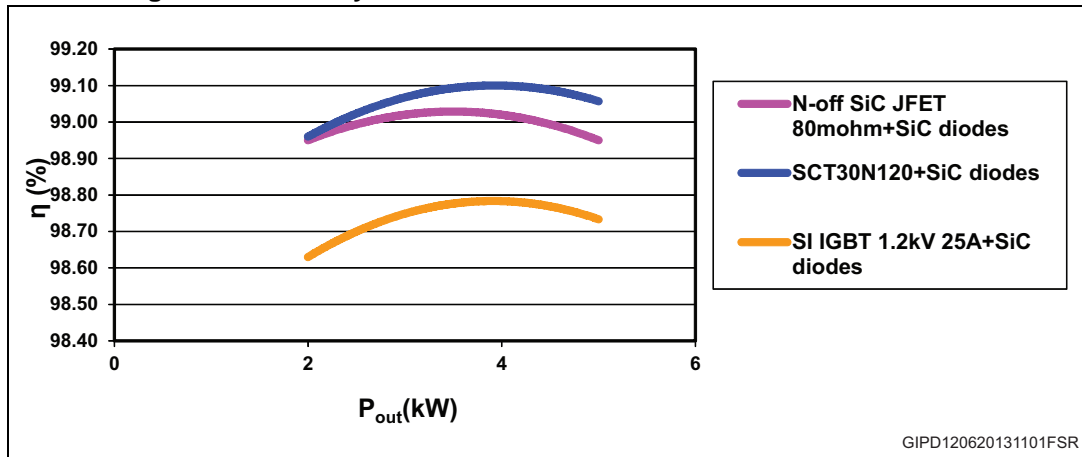

Figure 7. Case temperature values measured in the DC-DC boost @ 25 kHz

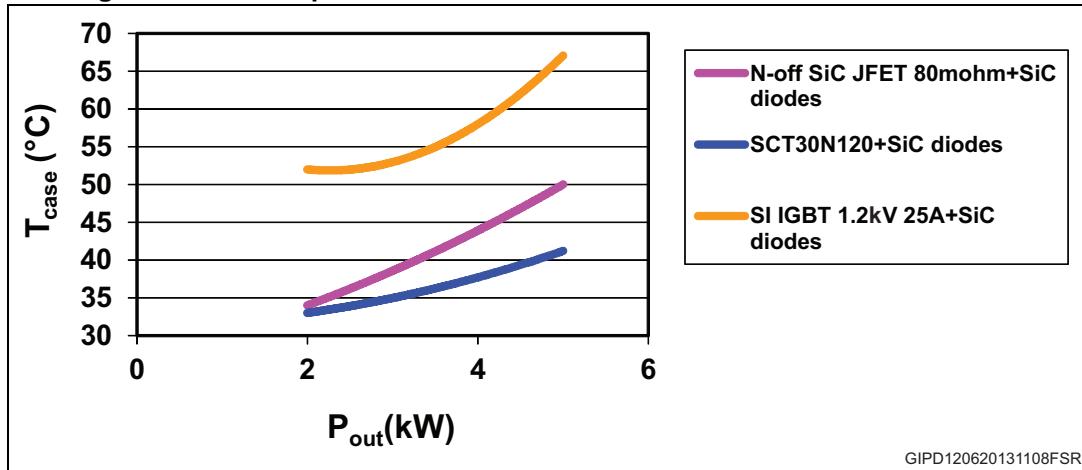

Figure 8. Efficiency values measured in the DC-DC boost @ 50 kHz

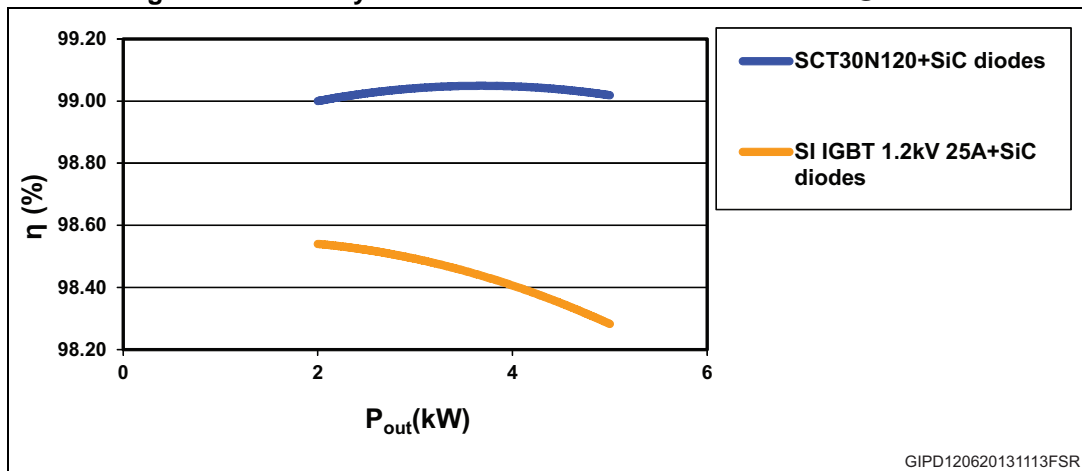

Figure 9. Case temperature values measured in the DC-DC boost @ 50 kHz

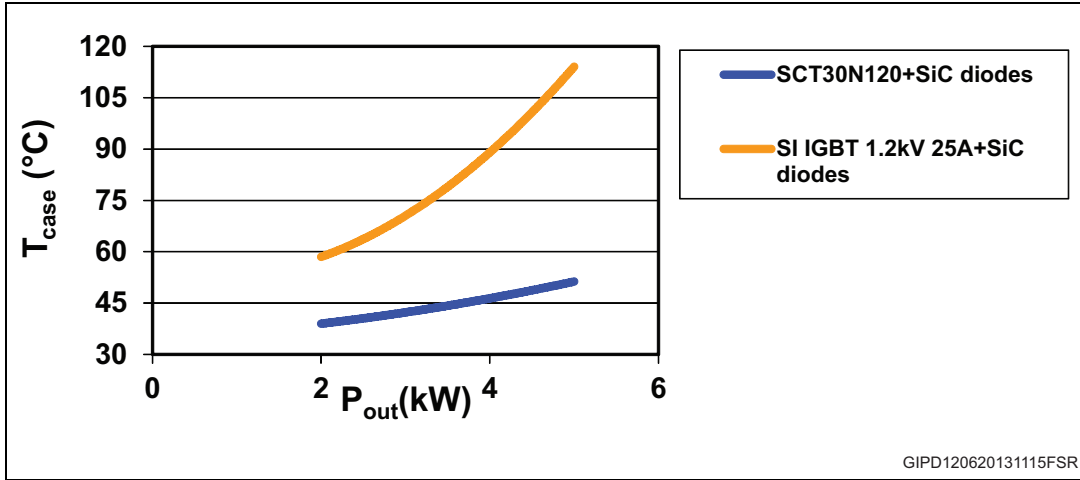

Figure 10. Efficiency values measured in the DC-DC boost @ 100 kHz and 125 kHz

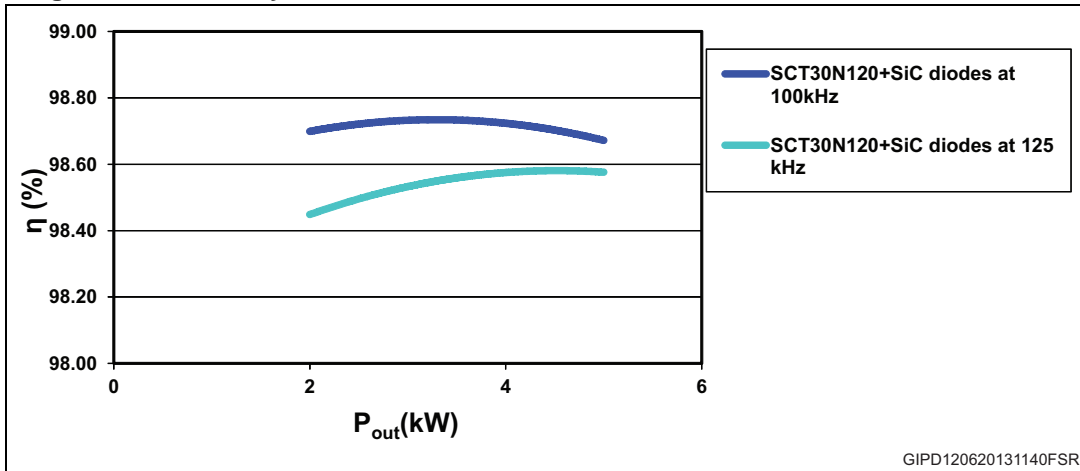

Figure 11. Case temperature values measured in the DC-DC boost @ 100 kHz and 125 kHz

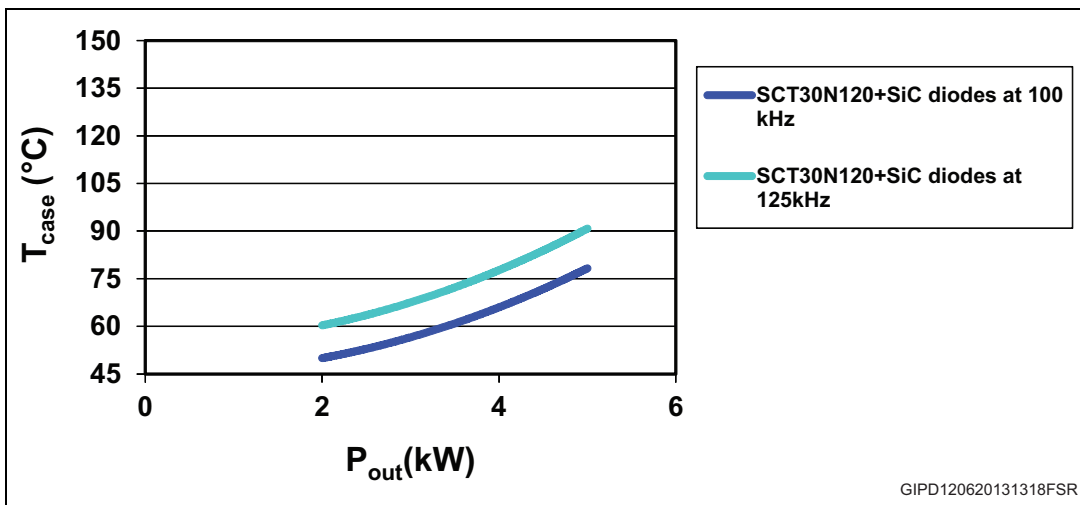

Figure 12. E_{on} (left) and E_{off} (right) of SiC MOSFET @ 125 kHz, 5 kW in the DC-DC boost

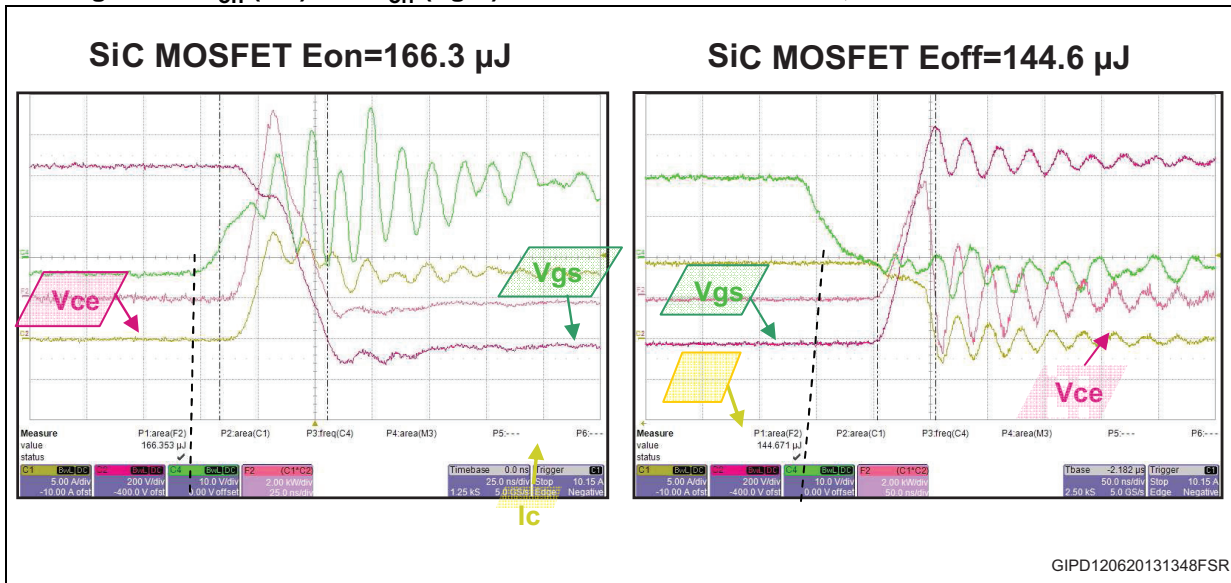
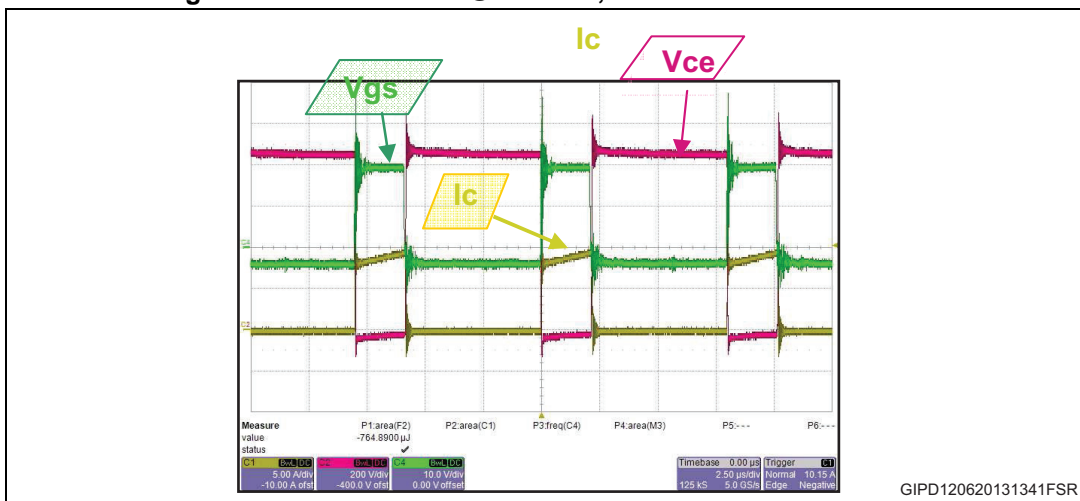

Figure 13. SiC MOSFET @ 125k Hz, 5 kW in the DC-DC boost



4 Conclusion

Experimental tests performed on a real 5 kW DC-DC boost demonstrator demonstrated that the 1.2 kV 80 mΩ SiC MOSFET prototype from ST is able to achieve better results than all 1.2 kV SiC and Si alternatives considered in this article, under electrical, thermal and driving aspects. If compared to the SiC JFET (OFF), whose complex driving stage construction required extreme care, it needed the same driving approach as a standard Si MOSFET, except for the positive 20 V of V_{gs} to be applied to the gate, achieving at the same time a higher level of efficiency than the SiC JFET. The Si IGBT is still a valid alternative at low f_{sw} of the converter, even if a lower efficiency has to be accepted by the user. On the contrary, the SiC MOSFET, with its breakthrough technology, is able to offer similar efficiency values at frequency values that are 4 times higher than those of the Si IGBT.

5 Literature

1. "Silicon Carbide Enhancement-Mode Junction Field Effect Transistor and Recommendations for Use", Semisouth.
2. "Direct comparison among different technologies in Silicon Carbide", Bettina Rubino, Michele Macaudo, Massimo Nania, Simone Buonomo, PCIM 2012.
3. "Application Considerations for Silicon Carbide MOSFETs", Bob Callanan, Cree.

6 Revision history

Table 4. Document revision history

Date	Revision	Changes
27-Sep-2013	1	Initial release.
11-Feb-2015	2	Updated <i>Section 2.1: SiC MOSFET vs silicon 1.2 kV IGBT: static comparison.</i> Minor text changes.

IMPORTANT NOTICE – PLEASE READ CAREFULLY

STMicroelectronics NV and its subsidiaries ("ST") reserve the right to make changes, corrections, enhancements, modifications, and improvements to ST products and/or to this document at any time without notice. Purchasers should obtain the latest relevant information on ST products before placing orders. ST products are sold pursuant to ST's terms and conditions of sale in place at the time of order acknowledgement.

Purchasers are solely responsible for the choice, selection, and use of ST products and ST assumes no liability for application assistance or the design of Purchasers' products.

No license, express or implied, to any intellectual property right is granted by ST herein.

Resale of ST products with provisions different from the information set forth herein shall void any warranty granted by ST for such product.

ST and the ST logo are trademarks of ST. All other product or service names are the property of their respective owners.

Information in this document supersedes and replaces information previously supplied in any prior versions of this document.

© 2015 STMicroelectronics – All rights reserved