

## Solution brief

# CoolGaN™ 600 V and GaN EiceDRIVER™

Cutting-edge performance with excellent reliability

The next essential step towards an energy-efficient world lies in the use of new materials and technologies. Wide bandgap semiconductors enable greater power efficiency, smaller size, lighter weight, lower cost, or all together.

### Key advantages of CoolGaN™ 600 V solution

- > The enhancement mode (e-mode) concept - the most robust and performing solution in the market
- > Industry-leading performance with the best figures-of-merit (FOM), enabling rugged and reliable system designs at an attractive overall system cost
- > Ten times higher breakdown field and a double electron mobility, compared to silicon
- > Ten times lower output and gate charge than silicon, enabling high frequency operations
- > Enabling hard switching in half-bridge topologies with an almost zero reverse recovery charge
- > Most reliable GaN solution in the market ensured through Infineon's pioneering qualification concept
- > A predicted lifetime of more than 15 years with a failure rate below 1 FIT
- > Perfect choice for a broad variety of applications such as server, telecom, hyperscale datacenters, adapters/chargers, wireless charging, SMPS and many others

### Driving CoolGaN™ HEMTs with GaN EiceDRIVER™ ICs

- > Positive and negative gate drive current enabling fast switching
- > Firmly holding gate drive voltage at zero when GaN switch is intended to be off, protects against spurious turn-on
- > Configurable and constant GaN switching slew-rates over a wide range of switching frequencies and duty cycles, results in robust and efficient GaN operation and short time-to-market
- > Integrated galvanic isolation
  - Robust operation in hard-switching applications
  - Mandatory where safety is required

### System features

- > The most reliable GaN-based solution, delivering highest performance amongst all available GaN devices
- > Manufacturing expertise throughout the entire supply chain
- > Global application design support
- > Broad portfolio including switches and drivers

### System benefits

- > Perfect choice for high frequency and high power density applications
- > Industry-leading solution for target applications
- > GaN EiceDRIVER™ ICs for excellent robustness and efficiency
- > High quality volume supply that enables faster time-to-market
- > Reduced BOM costs and overall system cost

## High efficiency GaN switched mode power supply (SMPS)

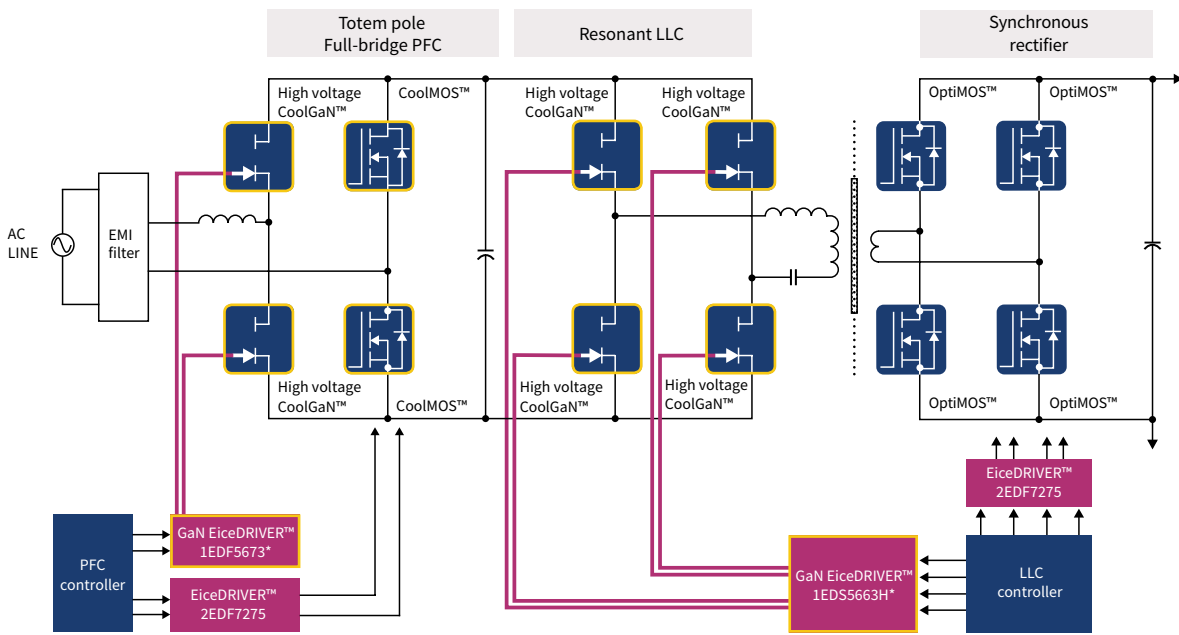

\*GaN EiceDRIVER™ ICs are single-channel products

### Product portfolio CoolGaN™ 600 V e-mode HEMTs

$R_{DS(on)max.}$ [mΩ]	DSO-20-85 Bottom-side cooling	DSO-20-87 Top-side cooling	HSOF-8-3 TO-leadless	LSON-8-1 DFN 8x8
35	IGO60R035D1**	IGOT60R035D1**	IGT60R035D1**	
70	IGO60R070D1	IGOT60R070D1	IGT60R070D1	IGLD60R070D1
190			IGT60R190D1S*	IGLD60R190D1

\* Standard \*\* Coming soon

### Product portfolio GaN EiceDRIVER™

Package	13-pin LGA 5x5 mm	16-pin DSO 150 mil	16-pin DSO 300 mil
Product	1EDF5673K	1EDF5673F	1EDS5663H
Isolation (input to output)	$V_{IO} = 1.5 \text{ kV}_{DC}$	$V_{IO} = 1.5 \text{ kV}_{DC}$	$V_{IOTM} = 8 \text{ kV}_{pk}$ (VDE0884-10)
Source/sink output resistance	0.85 Ω / 0.35 Ω	0.85 Ω / 0.35 Ω	0.85 Ω / 0.35 Ω
UVLO	4.5 V / 5.0 V	4.5 V / 5.0 V	4.5 V / 5.0 V

Published by  
Infineon Technologies Austria AG  
9500 Villach, Austria

© 2019 Infineon Technologies AG.  
All Rights Reserved.

**Please note!**

THIS DOCUMENT IS FOR INFORMATION PURPOSES ONLY AND ANY INFORMATION GIVEN HEREIN SHALL IN NO EVENT BE REGARDED AS A WARRANTY, GUARANTEE OR DESCRIPTION OF ANY FUNCTIONALITY, CONDITIONS AND/OR QUALITY OF OUR PRODUCTS OR ANY SUITABILITY FOR A PARTICULAR PURPOSE. WITH REGARD TO THE TECHNICAL SPECIFICATIONS OF OUR PRODUCTS, WE KINDLY ASK YOU TO REFER TO THE RELEVANT PRODUCT DATA SHEETS PROVIDED BY US. OUR CUSTOMERS AND THEIR TECHNICAL DEPARTMENTS ARE REQUIRED TO EVALUATE THE SUITABILITY OF OUR PRODUCTS FOR THE INTENDED APPLICATION.

WE RESERVE THE RIGHT TO CHANGE THIS DOCUMENT AND/OR THE INFORMATION GIVEN HEREIN AT ANY TIME.

**Additional information**

For further information on technologies, our products, the application of our products, delivery terms and conditions and/or prices, please contact your nearest Infineon Technologies office ([www.infineon.com](http://www.infineon.com)).

**Warnings**

Due to technical requirements, our products may contain dangerous substances. For information on the types in question, please contact your nearest Infineon Technologies office.

Except as otherwise explicitly approved by us in a written document signed by authorized representatives of Infineon Technologies, our products may not be used in any life-endangering applications, including but not limited to medical, nuclear, military, life-critical or any other applications where a failure of the product or any consequences of the use thereof can result in personal injury.